

# Raised Garden Bed

## User Guide

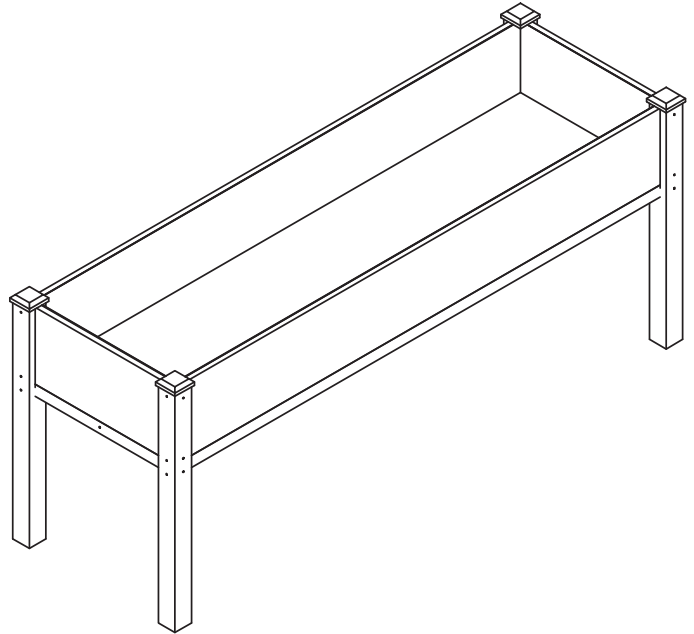

Thank you for purchasing the Raised Garden Bed. This User Guide is intended to provide you with guidelines to ensure that operation of this product is safe and does not pose risk to the user. Any use that does not conform to the guidelines described in this User Guide may void the limited warranty.

Please read all directions before using the product and retain this guide for reference. This product is intended for household use only. It is not intended for commercial use.

This product is covered by a limited one-year warranty. Coverage is subject to limits and exclusions. See warranty for details.





### Safety Precautions

- Make sure to use safety eyewear and gloves during the assembly process to avoid injury.
- Be sure to read and follow all operating instructions for any tools you use during assembly.
- No saw cutting is required. You should not need to use a saw on these products.
- Do not attempt to modify the product. We are not liable for any damage or injuries that occur as a result of modifications to these products.
- Before starting assembly, please verify that all parts are present and not damaged. If you are missing any parts, please contact customer care.
- Once assembled, ensure that anything you put into the garden bed does not exceed the recommended weight limit of 441 lbs. (200 kgs) or else the product could break or become otherwise damaged.

### Specifications

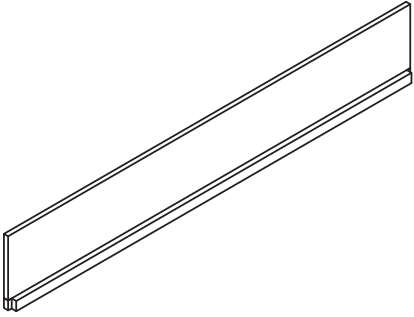
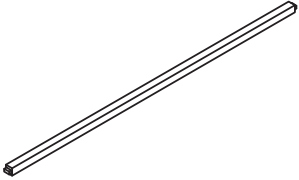
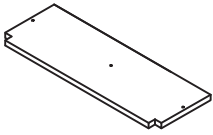
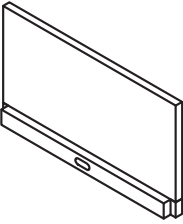
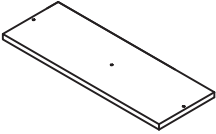
- Dimensions: 72" x 23" x 30" (182.9 x 58.4 x 76.2 cm)
- Weight Limit: 441 lbs. (200 kgs)

## Package Contents

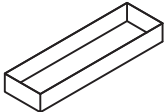
1		2PCS	4		1PC
			5		2PCS
2		2PCS	6		7PCS
			7		4PCS
3		4PCS	8	 5x90mm	26PCS
			9	 3.5x30mm	27PCS
			10		1PC

# Assembly Instructions

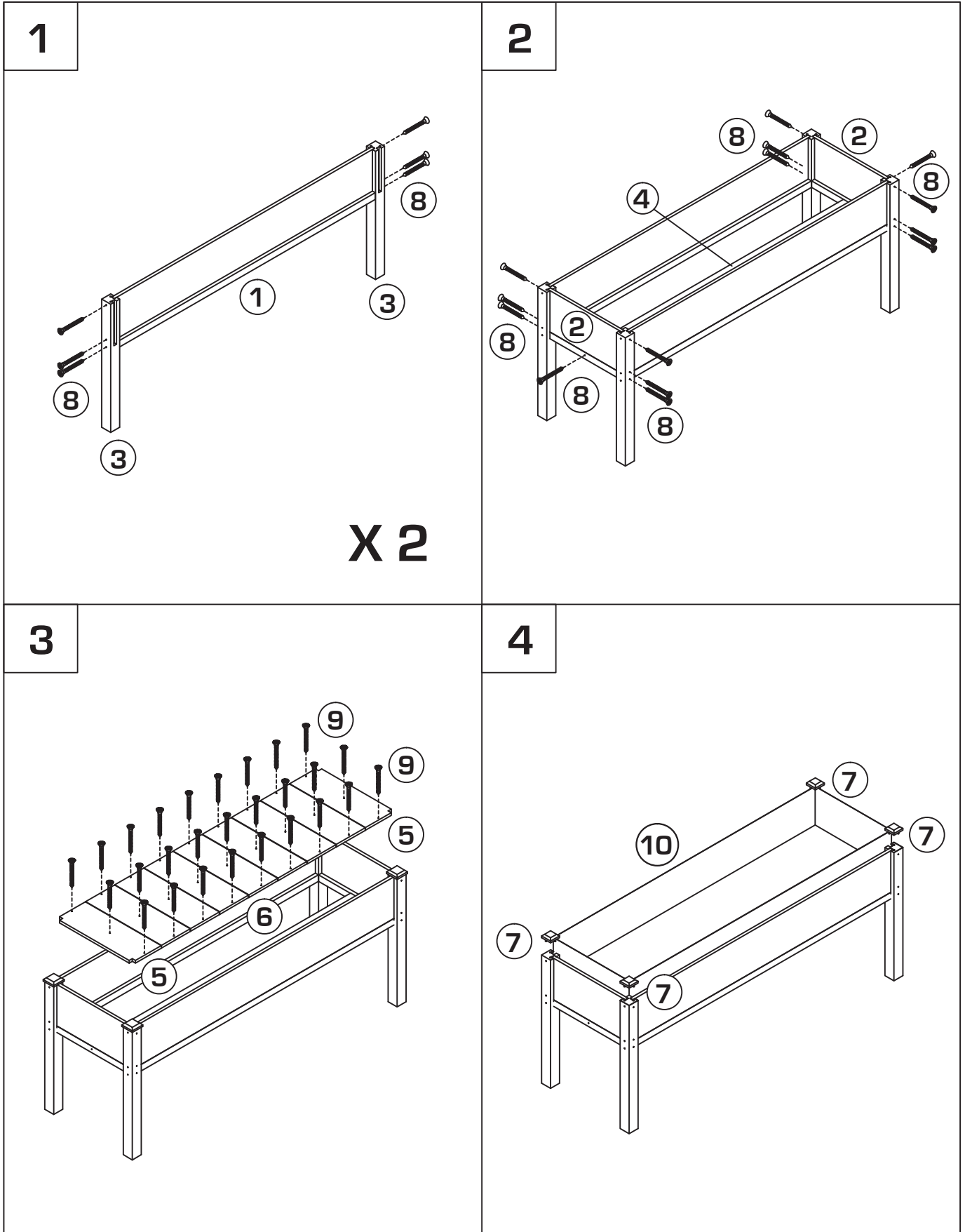

# Warranty

LIMITED WARRANTY ON RAISED GARDEN BEDS  
THIS LIMITED WARRANTY GIVES YOU SPECIFIC LEGAL RIGHTS AND YOU MAY ALSO HAVE  
OTHER RIGHTS, WHICH VARY FROM STATE TO STATE.

WE WARRANT THAT DURING THE WARRANTY PERIOD, THE PRODUCT WILL BE  
FREE FROM DEFECTS IN MATERIALS AND WORKMANSHIP.

## LIMITATION OF LIABILITY

TO THE EXTENT NOT PROHIBITED BY LAW, THIS WARRANTY IS EXCLUSIVE AND IN LIEU OF ALL OTHER WARRANTIES, ORAL, WRITTEN, STATUTORY, EXPRESS OR IMPLIED. EXCEPT FOR THE EXPRESS WARRANTIES CONTAINED IN THIS LIMITED WARRANTY STATEMENT AND TO THE EXTENT NOT PROHIBITED BY LAW, WE DISCLAIM ALL OTHER WARRANTIES, EXPRESSED OR IMPLIED, STATUTORY OR OTHERWISE, INCLUDING WITHOUT LIMITATION, THE WARRANTIES OF MERCHANTABILITY AND FITNESS FOR A PARTICULAR PURPOSE. SOME STATES DO NOT ALLOW DISCLAIMERS OF IMPLIED WARRANTIES, SO THIS DISCLAIMER MAY NOT APPLY TO YOU. TO THE EXTENT SUCH WARRANTIES CANNOT BE DISCLAIMED UNDER THE LAWS OF YOUR JURISDICTION, WE LIMIT THE DURATION AND REMEDIES OF SUCH WARRANTIES TO THE DURATION OF THIS EXPRESS LIMITED WARRANTY.

OUR RESPONSIBILITY FOR DEFECTIVE GOODS IS LIMITED TO REPAIR, REPLACEMENT  
OR REFUND AS DESCRIBED BELOW IN THIS WARRANTY STATEMENT.

**WHO MAY USE THIS WARRANTY?** (“we”) extend this limited warranty only to the consumer who originally purchased the product (“you”). It does not extend to any subsequent owner or other transferee of the product.

**WHAT DOES THIS WARRANTY COVER?** This limited warranty covers defects in materials and workmanship of the Raised Garden Beds (the “product”) for the Warranty Period as defined below.

**WHAT DOES THIS WARRANTY NOT COVER?** This limited warranty does not cover any damage due to: (a) transportation; (b) storage; (c) improper use; (d) failure to follow the product instructions or to perform any preventive maintenance; (e) modifications; (f) unauthorized repair; (g) normal wear and tear; or (h) external causes such as accidents, abuse, or other actions or events beyond our reasonable control.

**WHAT IS THE PERIOD OF COVERAGE?** This limited warranty starts on the date of your purchase and lasts for one year (the “Warranty Period”). The Warranty Period is not extended if we repair or replace the product. We may change the availability of this limited warranty at our discretion, but any changes will not be retroactive.

**WHAT ARE YOUR REMEDIES UNDER THIS WARRANTY?** With respect to any defective product during the Warranty Period, we will, at our sole discretion, either: (a) repair or replace such product (or the defective part) free of charge or (b) refund the purchase price of such product if an exchange unit cannot be provided.

**HOW DO YOU OBTAIN WARRANTY SERVICE?** To obtain warranty service, you must contact us, during the Warranty Period to obtain a Defective Merchandise Authorization (“DMA”) number. No warranty service will be provided without a DMA number and return shipping costs to our facilities shall be assumed by you, the purchaser. Shipping costs of the replacement unit to you shall be assumed by us.