

EN:

CAUTION:

- * Before using the chair, ensure that all bolts are fully tightened.
- * Lubricate all moving parts and retighten all bolts every 6 months or as needed.

To remove odor, air the chair outdoors in shade for 1-2 days.



Periodically retighten all bolts. Do not use an electric screwdriver.

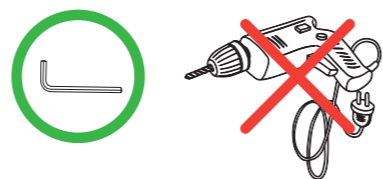

ES:

PRECAUCIÓN:

- * Antes de usar la silla, asegúrese de que todos los tornillos estén bien apretados.
- * Lubrique las piezas móviles y reapriete todos los tornillos cada seis meses o según sea necesario.

Para eliminar el olor, airee la silla al aire libre, a la sombra, durante 1-2 días.



Reapriete periódicamente todos los tornillos. No utilice un atornillador eléctrico.

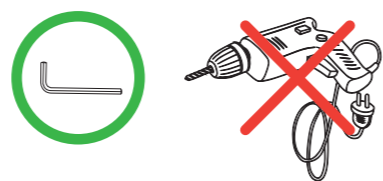

FR :

ATTENTION :

- * Avant d'utiliser la chaise, assurez-vous que tous les boulons sont complètement serrés.
- * Lubrifiez toutes les pièces mobiles et resserrez tous les boulons tous les six mois ou au besoin.

Pour éliminer les odeurs, aérez la chaise à l'extérieur à l'ombre pendant 1 à 2 jours.



Resserrez périodiquement tous les boulons. N'utilisez pas de tournevis électrique.

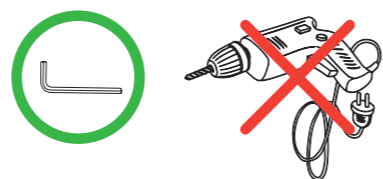

Safety Information / Información de seguridad / Informations Relatives à la Sécurité



**INSTRUCTION MANUAL
MANUAL DE INSTRUCCIONES
MANUEL D'INSTRUCTIONS**

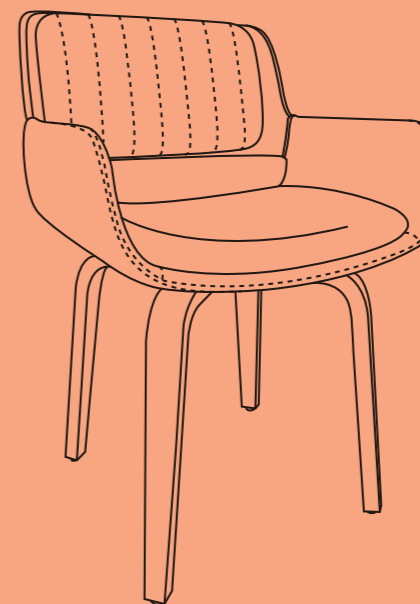

A ×1

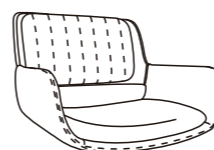

B ×1

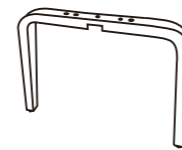

C ×1



D ×1

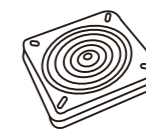

E ×1

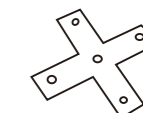

1 ×9



M6x30mm

2 ×4



M6x20mm

3 ×1



EN:  Fully tighten the bolts.

ES:  Apriete completamente los tornillos.

FR:  Serrez complètement les boulons.

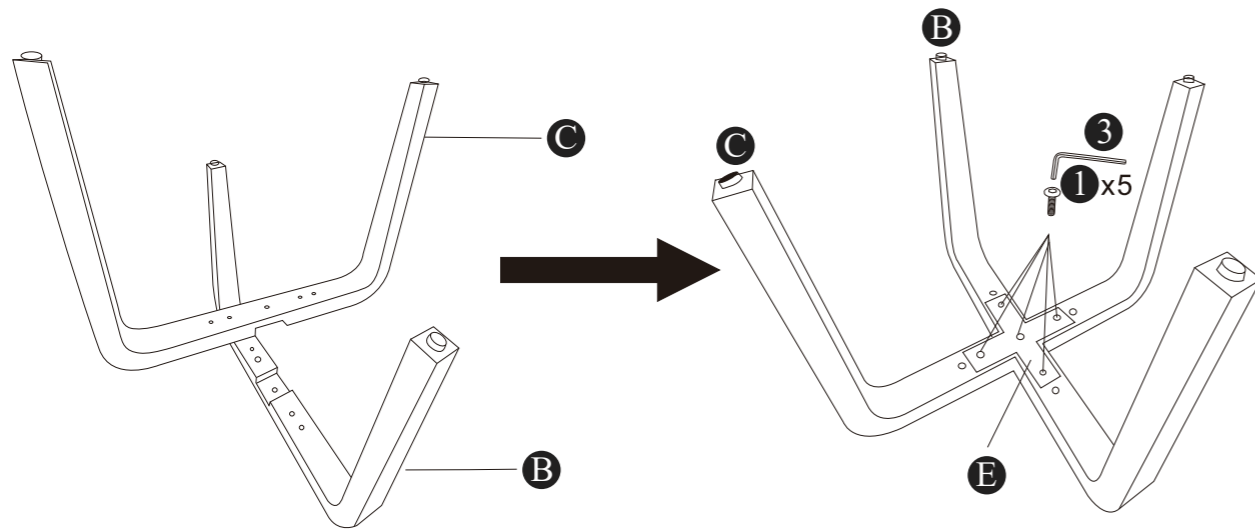
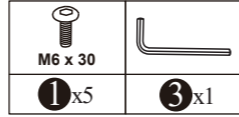

1

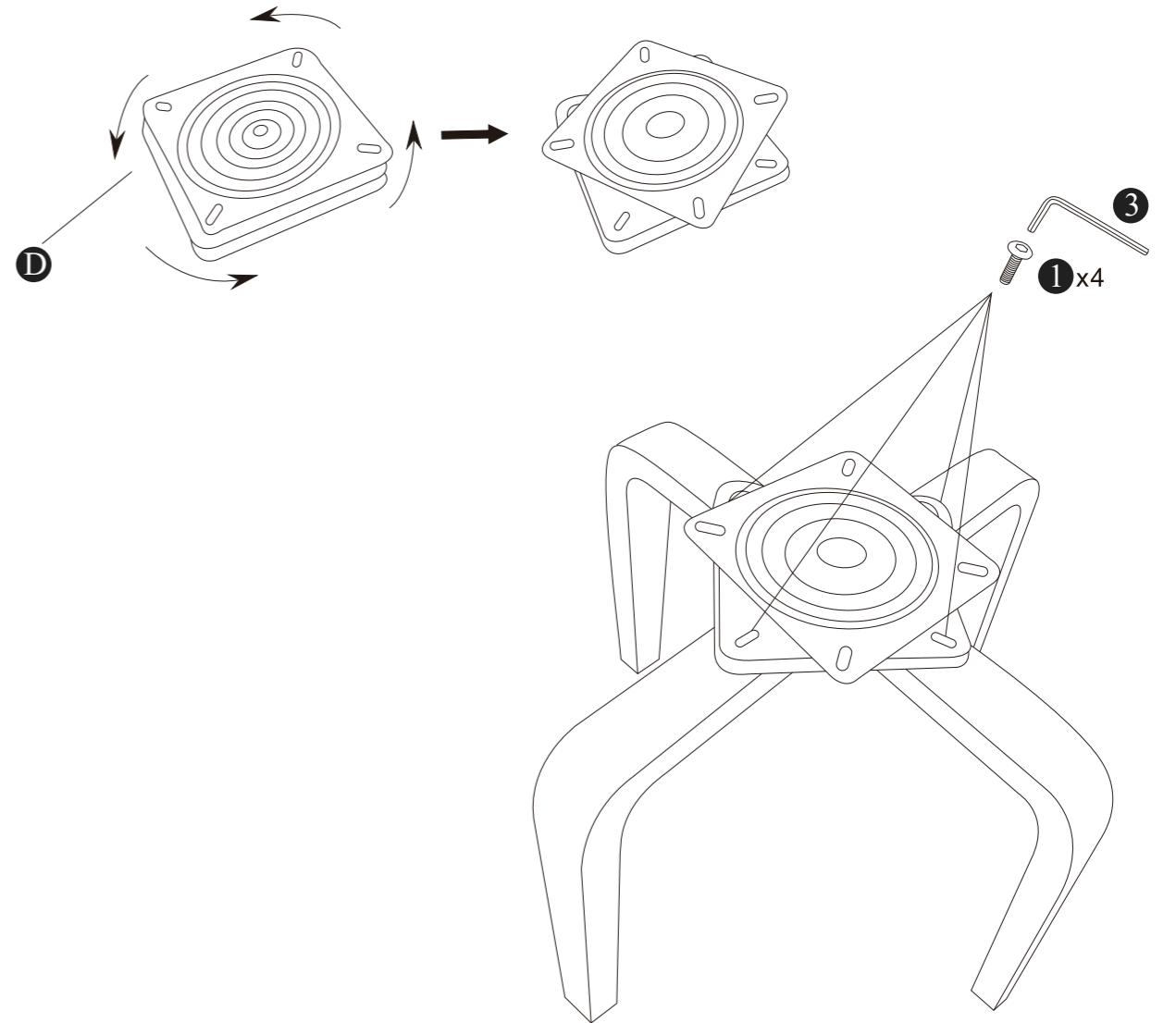
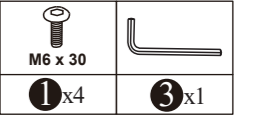

2



M6 x 20	
2 x4	3 x1

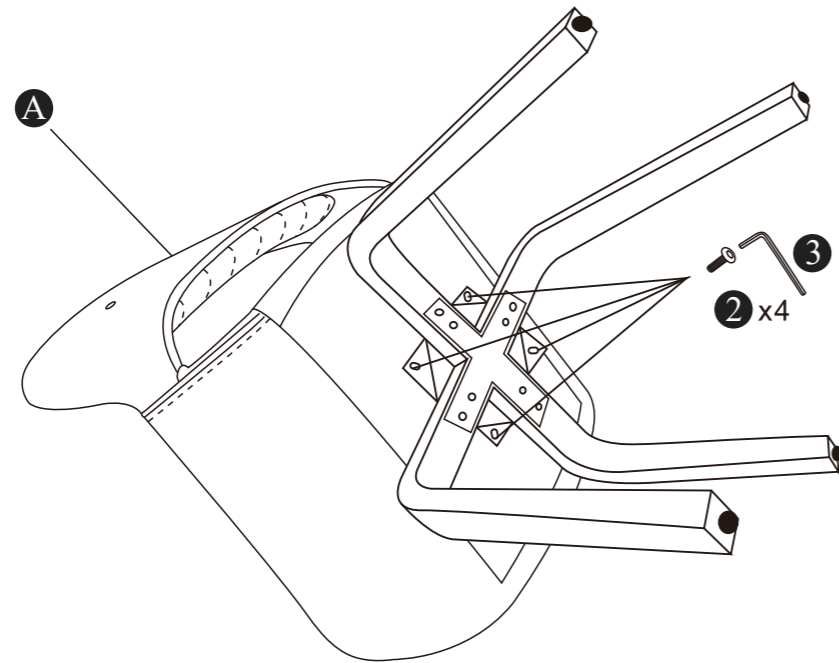

3

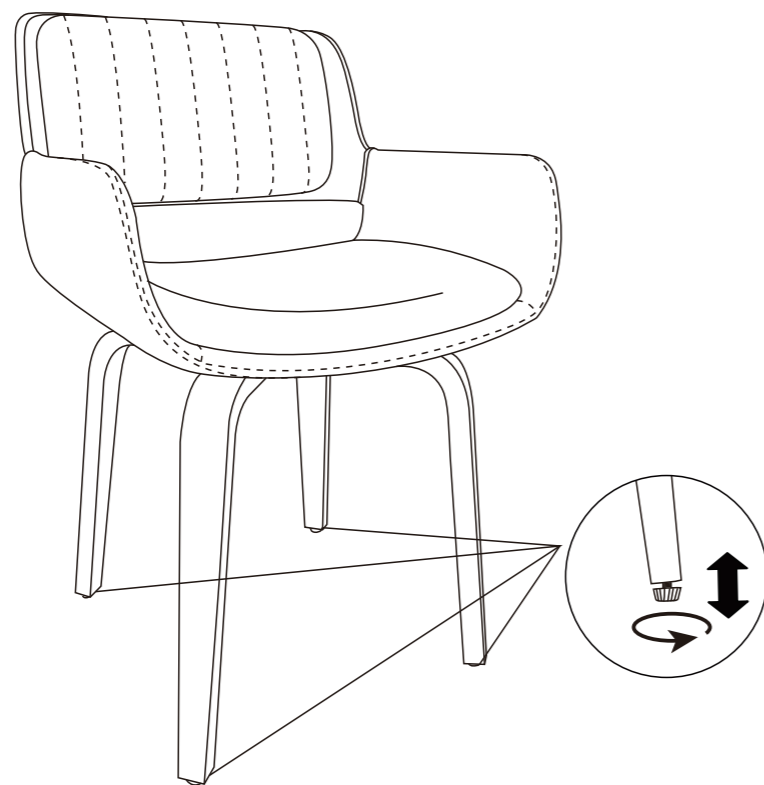

4



5