

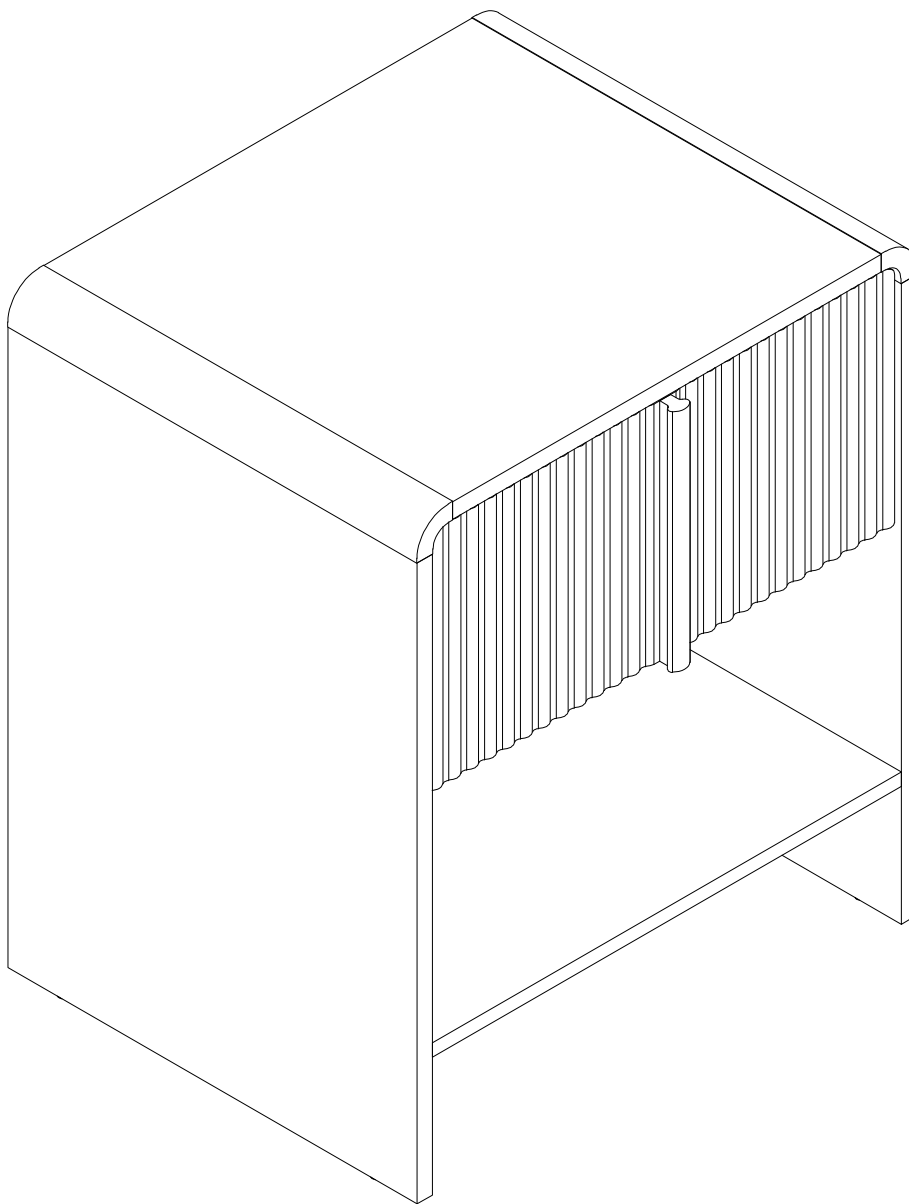

**MANHATTAN  
COMFORT**

---

**NS1669**



V.08082025

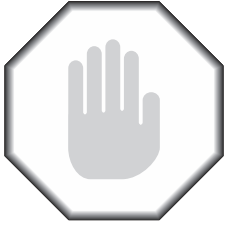

# STOP!

Before beginning the assembly process, ensure all boxes and parts have been delivered.

## FOR BEST RESULTS:

- Do not throw away packaging materials until assembly is complete.
- Assemble item on a soft surface, such as cardboard or carpet, to protect finish.
- Proper assembly requires two people.

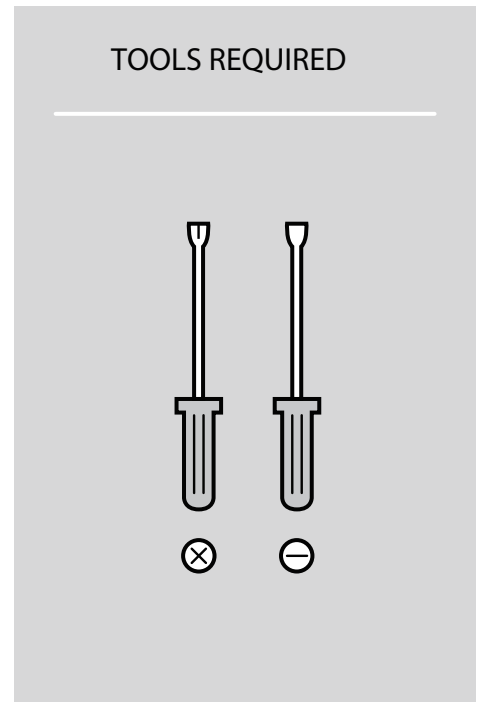
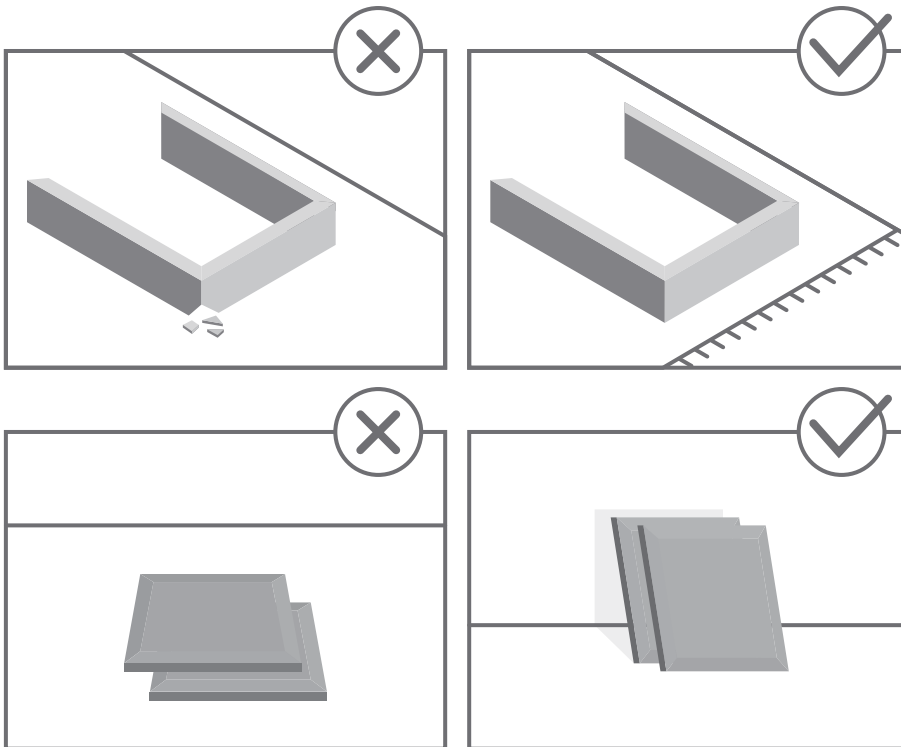

View our assembly video online:  
[WWW.MANHATTANCOMFORT.COM](http://WWW.MANHATTANCOMFORT.COM)



Stuck? Question? We are here to help.  
tel: 908-888-0818  
e-mail: [help@manhattancomfort.com](mailto:help@manhattancomfort.com)

Support Site



# Included in this package:

- A. TOP PANEL(1)
- B. BOTTOM PANEL(1)
- C. LEFT PANEL (1)
- D. RIGHT PANEL (1)
- E. BACK PANEL (1)
- F. FRONT HORIZONTAL PANEL (1)
- G. CURVED BAR (2)
- H. DRAWER LEFT PANEL (1)
- I. DRAWER RIGHT PANEL (1)
- J. DRAWER BACK PANEL (1)
- K. DRAWER BOTTOM PANEL (1)
- L. DRAWER SUPPORT PANEL (1)
- M. DRAWER FRONT PANEL (1)
- N. HANDLE (1)

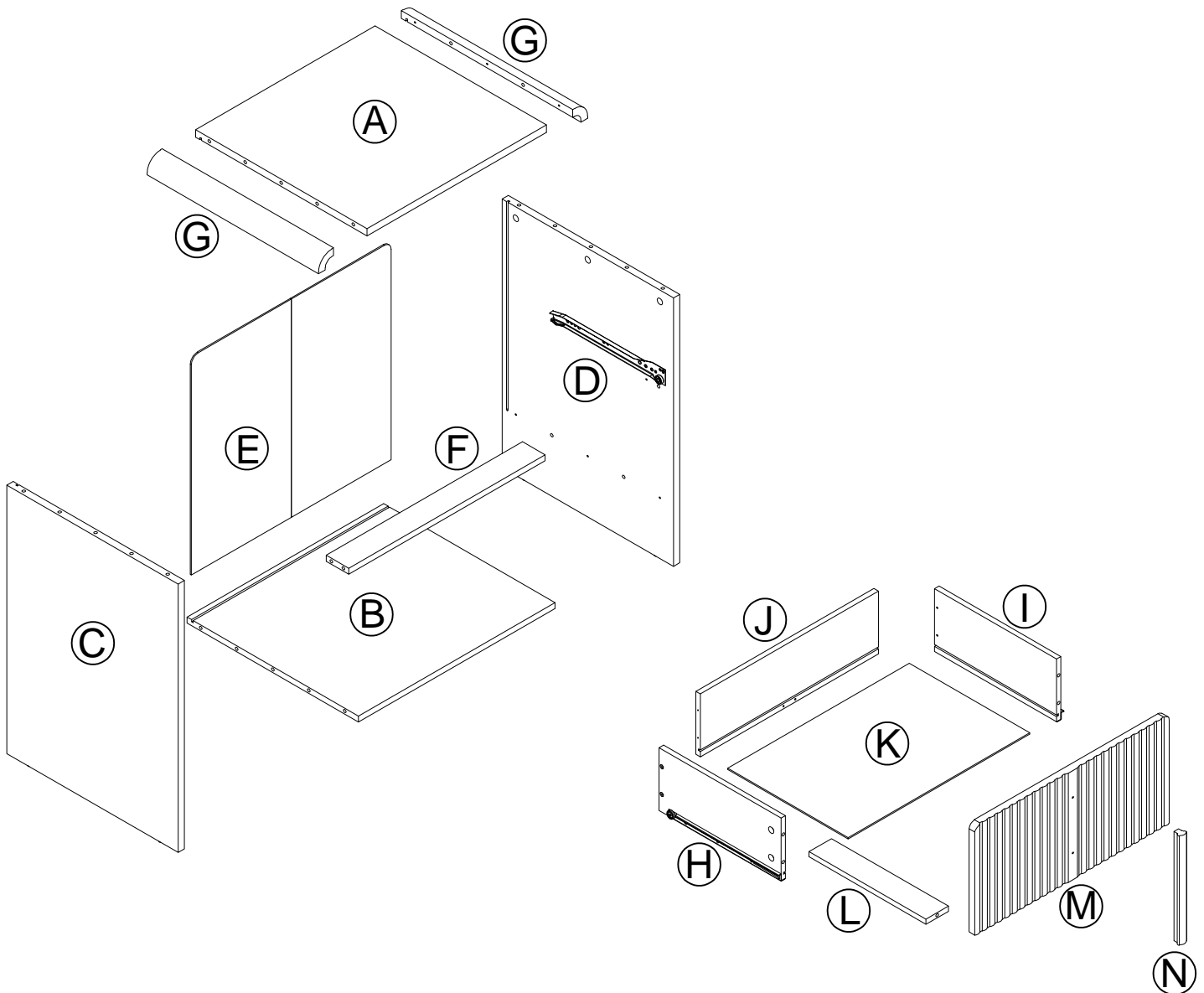

# Hardware Identification

---

① KD BOLT - 25pcs  
L=35mm

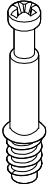

② KD LARGE CAM - 20pcs  
Ø15\*11mm

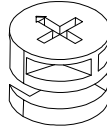

③ COVER CAP - 25pcs

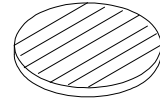

④ WOOD DOWEL-14pcs  
Ø8\*30mm

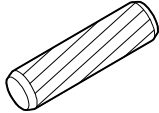

⑤ KD SMALL CAM - 5pcs  
Ø15\*9mm

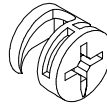

⑥ SCREW - 6pcs  
Ø4\*38mm

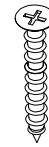

⑦ PLASTIC WEDGE - 10pcs

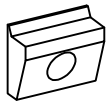

⑧ SCREW - 10pcs  
Ø3\*17mm

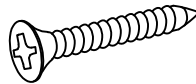

⑨ BOLT - 2pcs

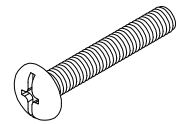

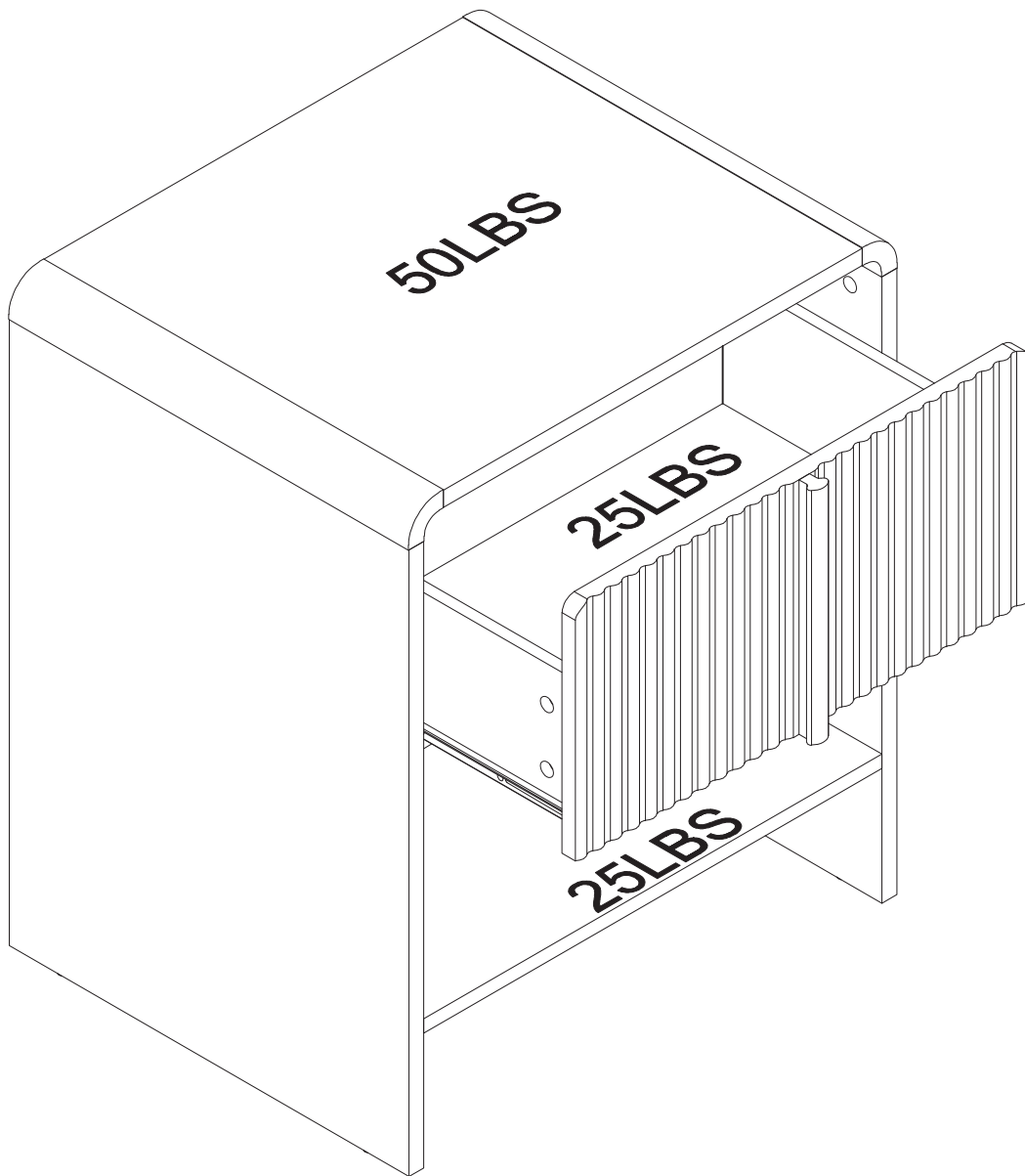

# Step 1:

\* Insert Twenty KD BOLT (1) to the LEFT PANEL (C), RIGHT PANEL(D) and Two the CURVED BAR (G).

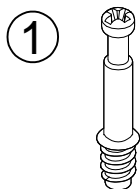

( 20 PCS )

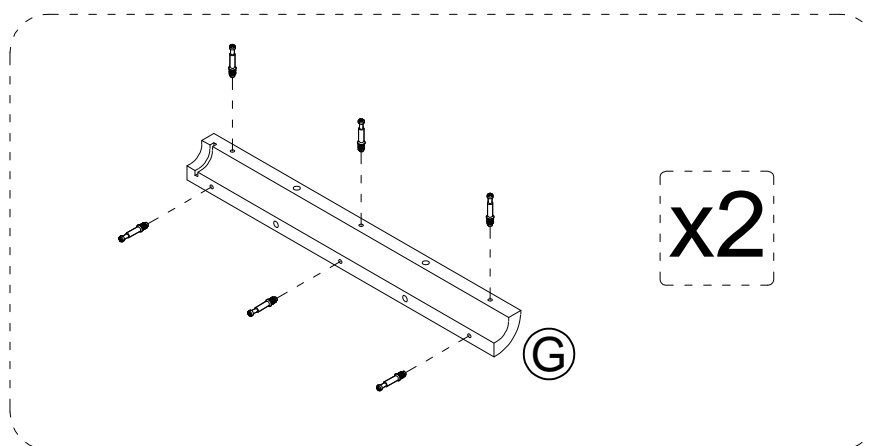
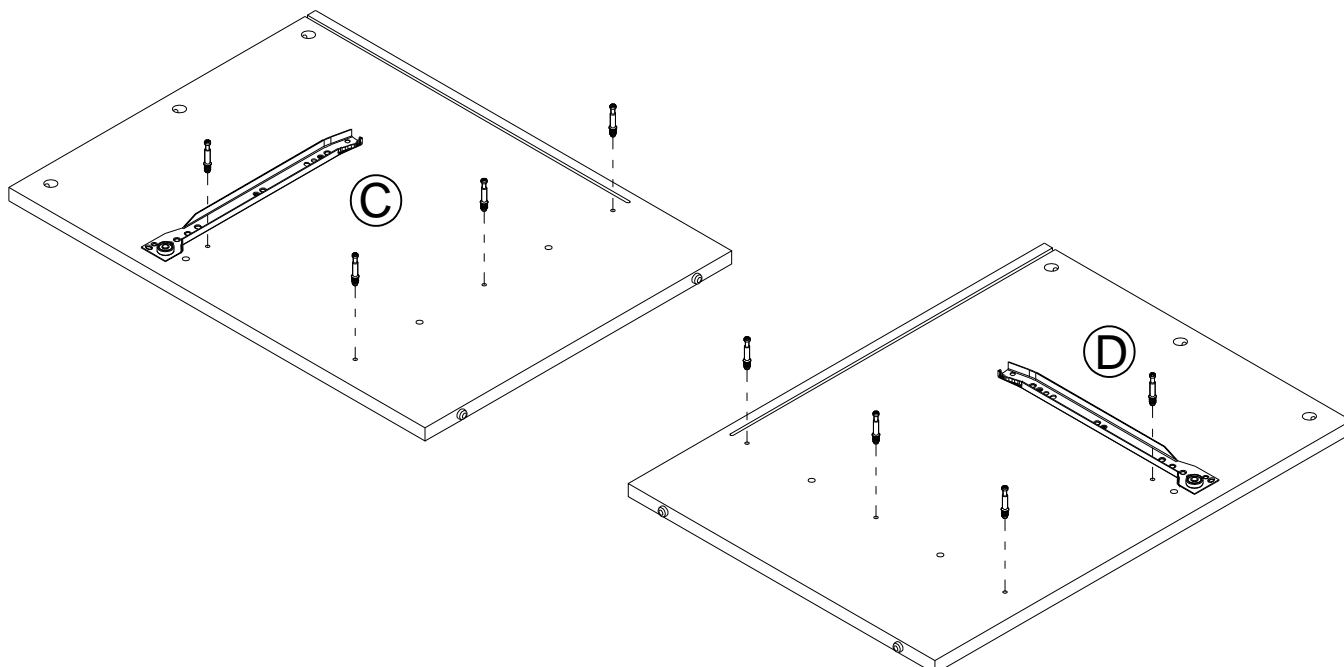

## Step 2:

\* Attach the FRONT HORIZONTAL PANEL (F) and BOTTOM PANEL (B) to the LEFT PANEL (C) and RIGHT PANEL (D) by the Eight KD LARGE CAM (2) , Eight COVER CAP (3) and Six WOOD DOWEL (4) .

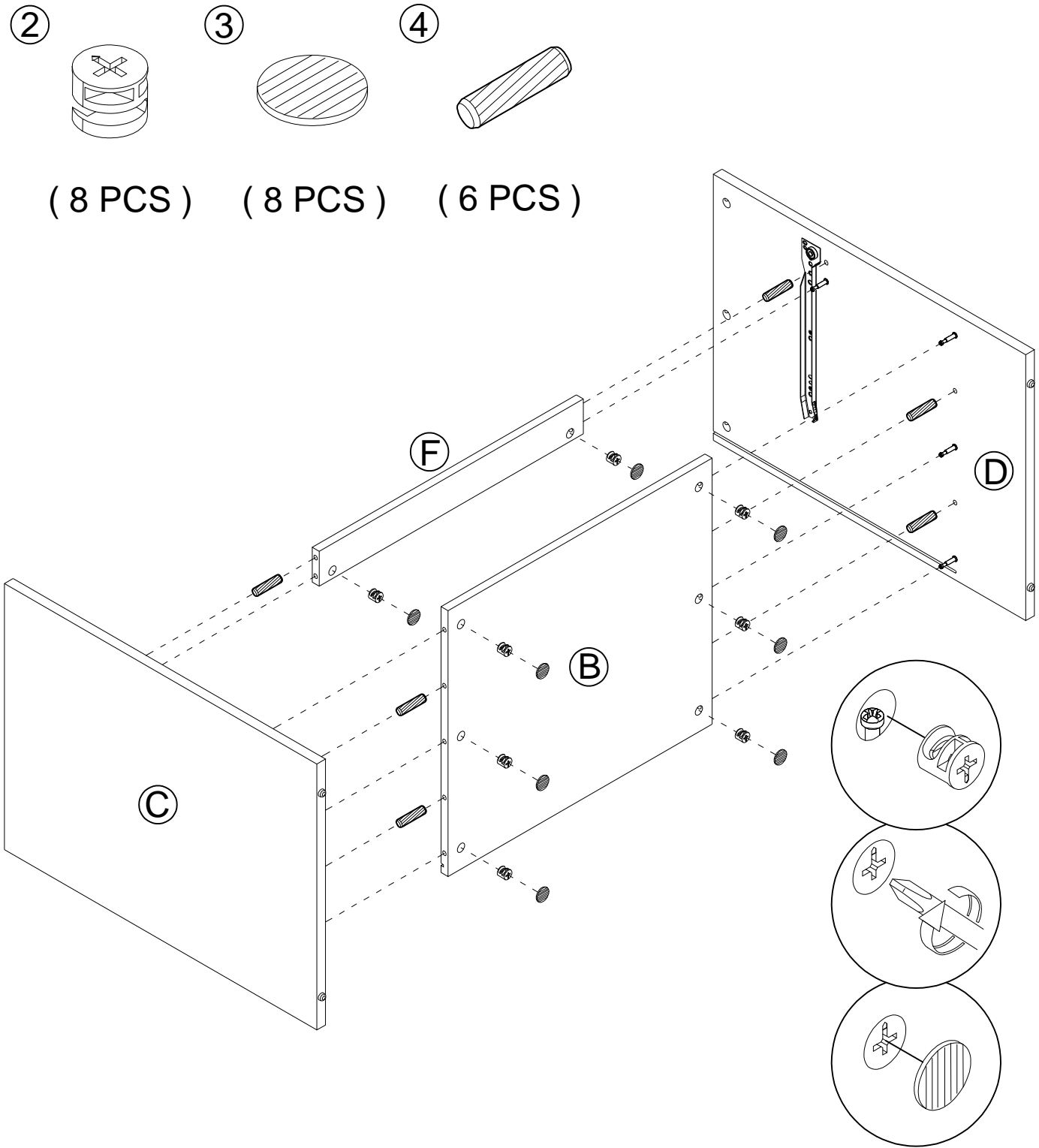

## Step 3:

\* Insert the BACK PANEL (E) to the stand.

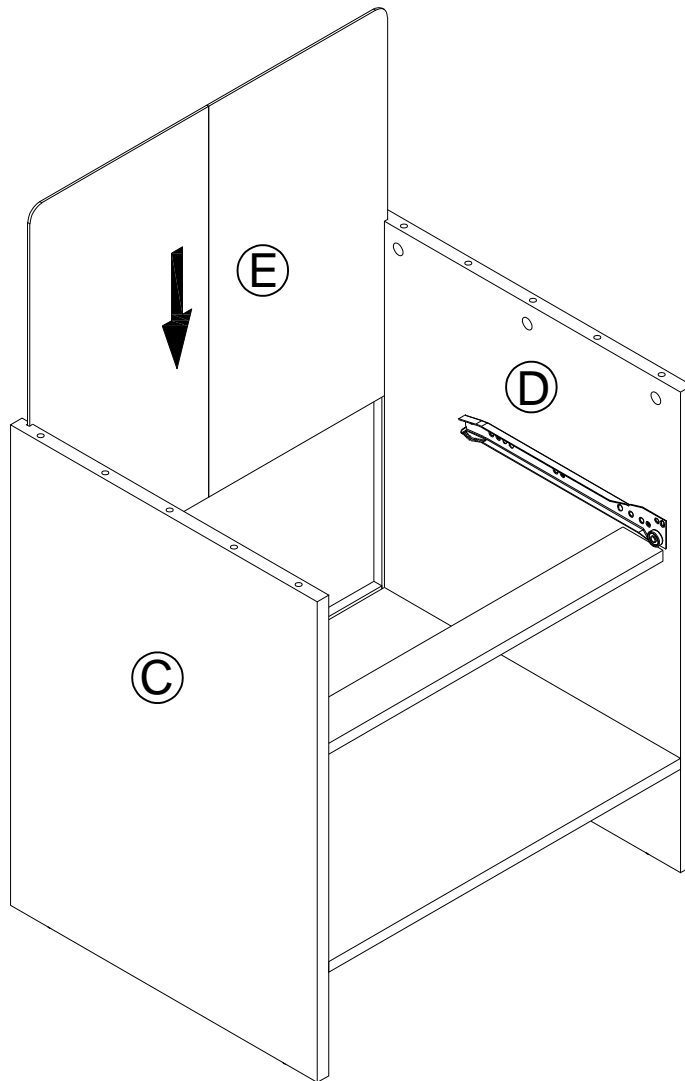

# Step 4:

\* Attach the TOP PANEL (A) to the Two the CURVED BAR (G) by the Six KD LARGE CAM (2) , Six COVER CAP (3) and Four WOOD DOWEL (4) .

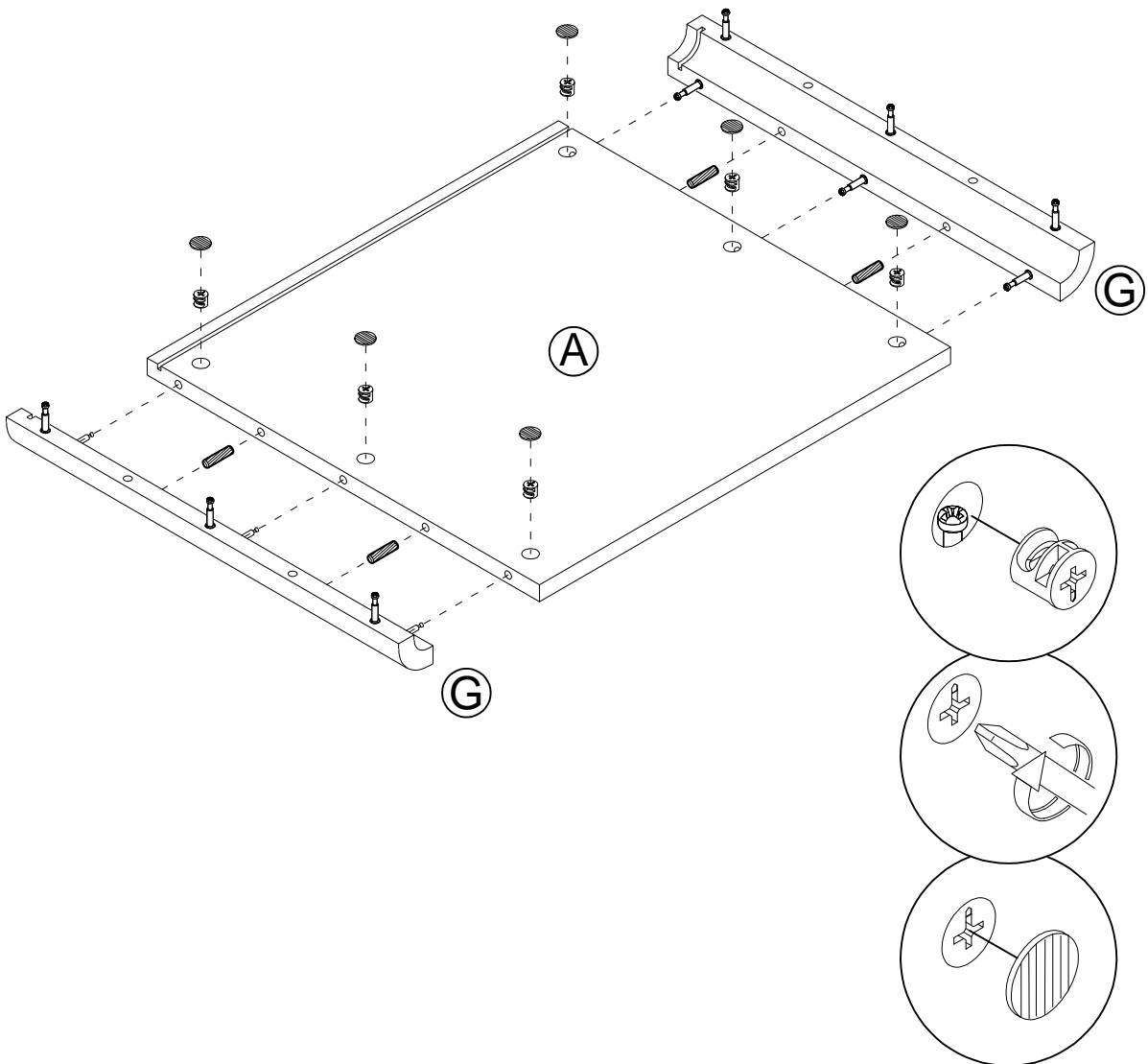
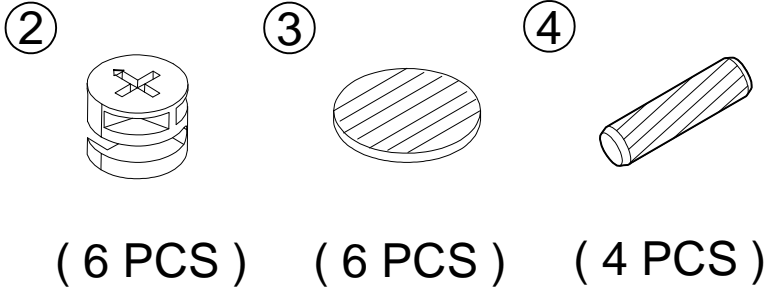

# Step 5:

\* Attach Two the CURVED BAR (G) to the LEFT PANEL (C) and RIGHT PANEL (D) by the Six KD LARGE CAM (2) , Six COVER CAP (3) and Four WOOD DOWEL (4) .

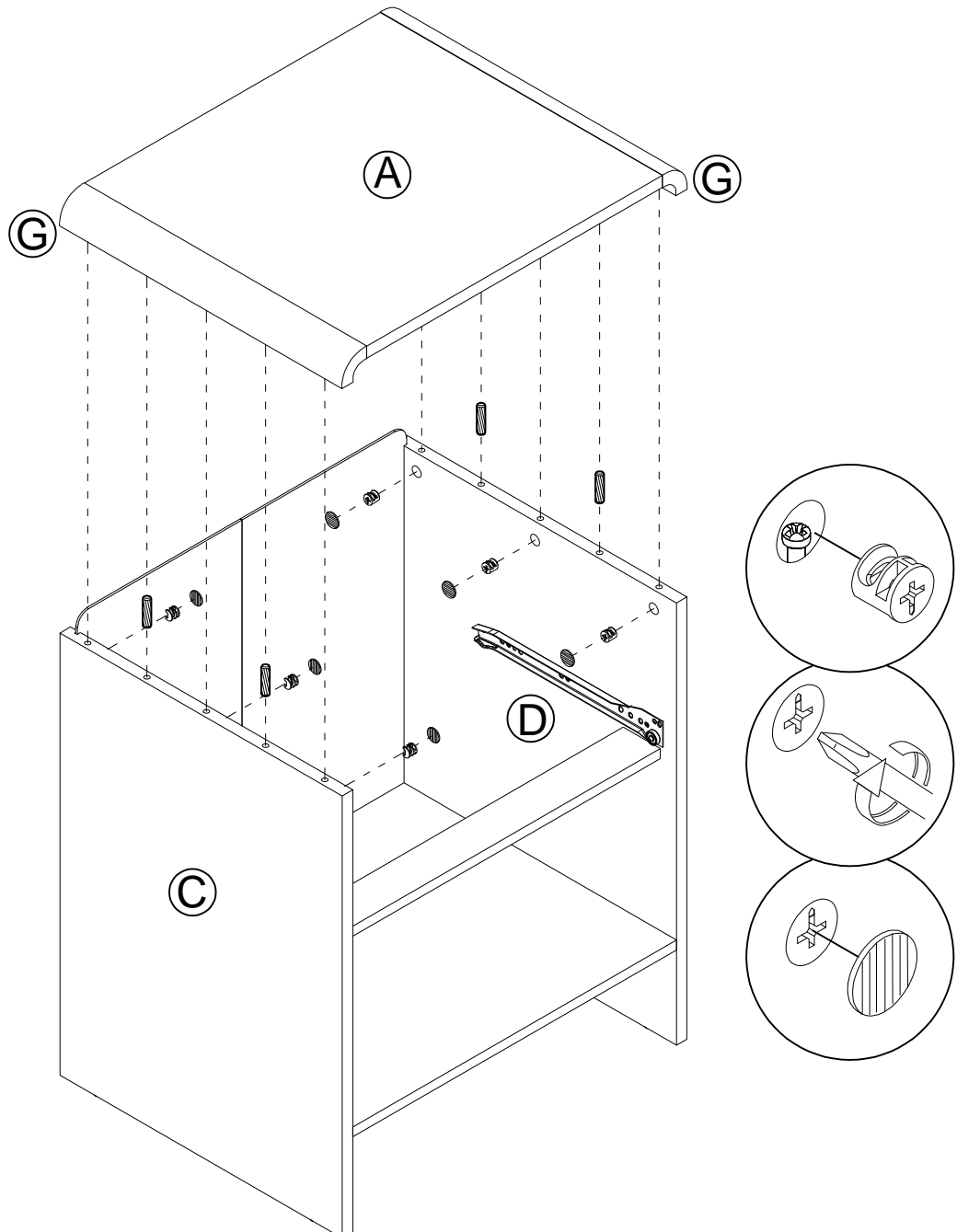
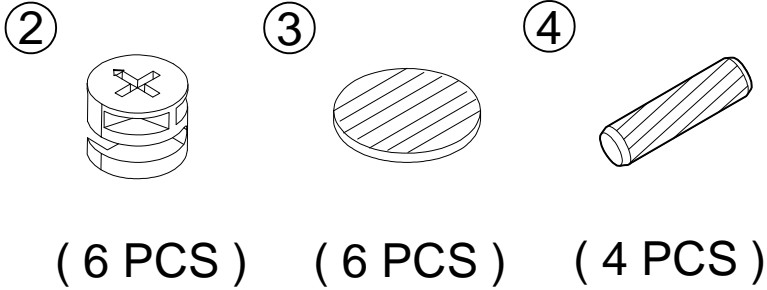

# Step 6:

\* Insert Ten PLASTIC WEDGE(7) and Eight SCREW(8) to the BACK PANEL (E).

⑦

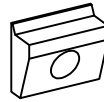

( 10 PCS )

⑧

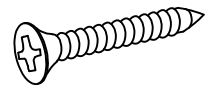

( 10 PCS )

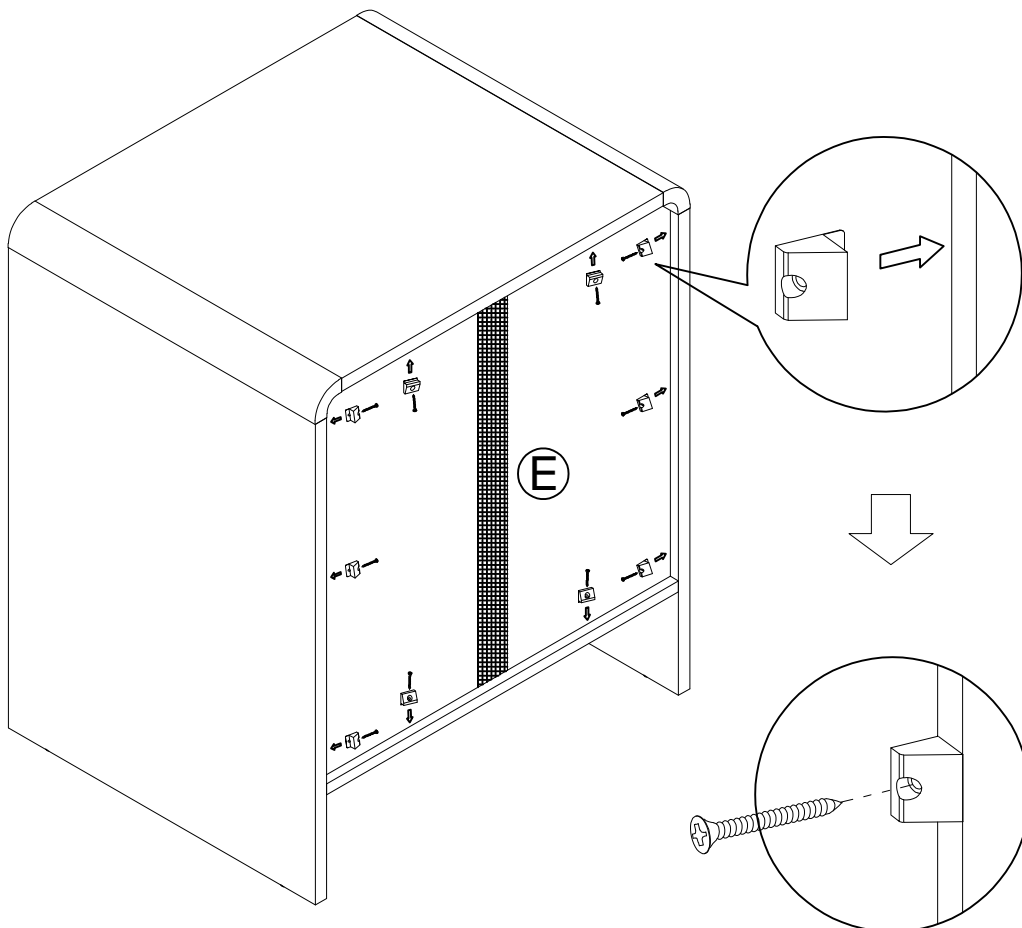

## Step 7:

\* Assemble the DRAWER BACK PANEL (J) to the DRAWER LEFT PANEL (H) and DRAWER RIGHT PANEL (I) by the SCREW (6) .

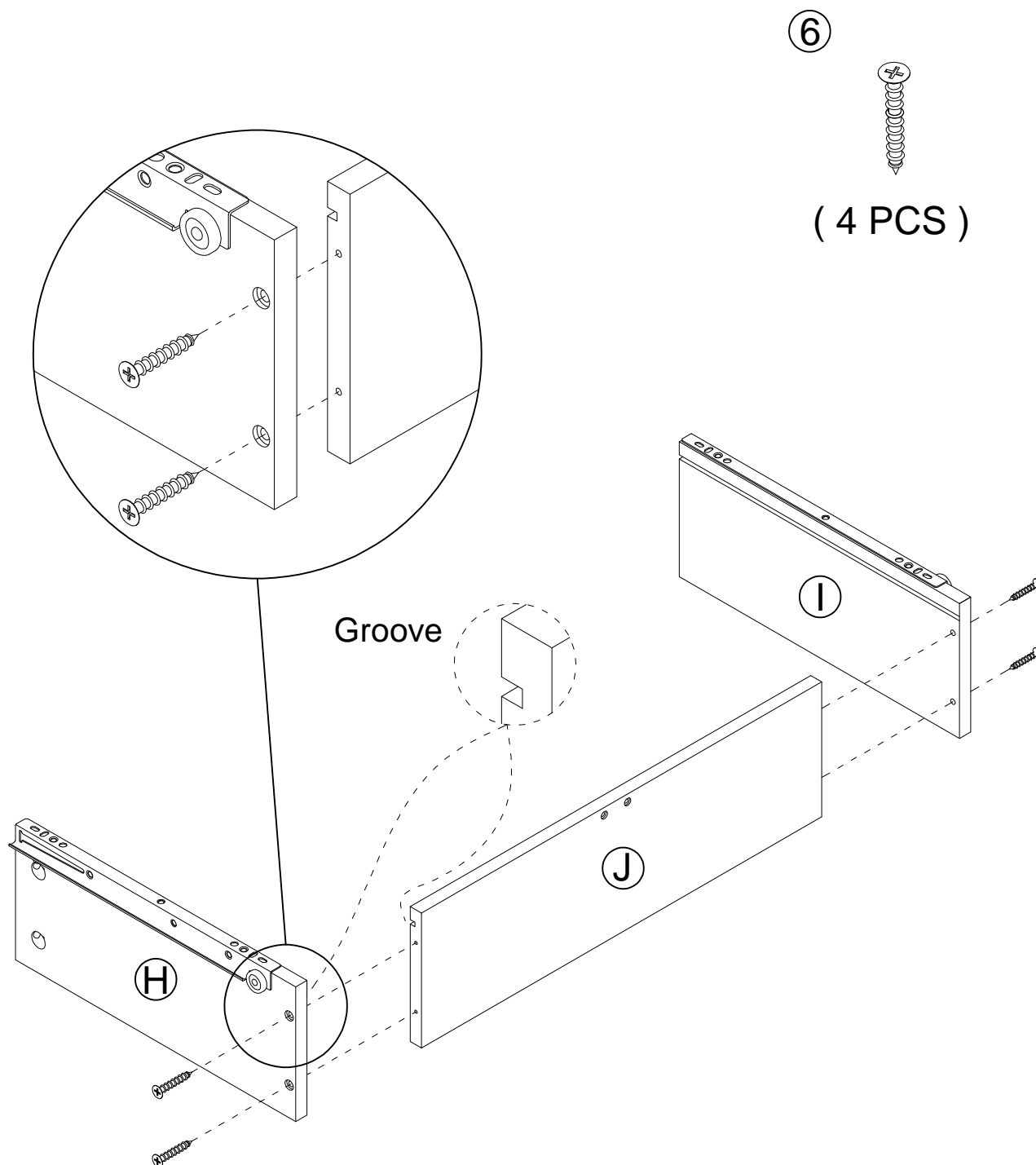

## Step 8:

---

- \* Slide in the DRAWER BOTTOM PANEL (K).
- \* Assemble the DRAWER SUPPORT PANEL (L) to the DRAWER TRAY by the SCREW (6) .

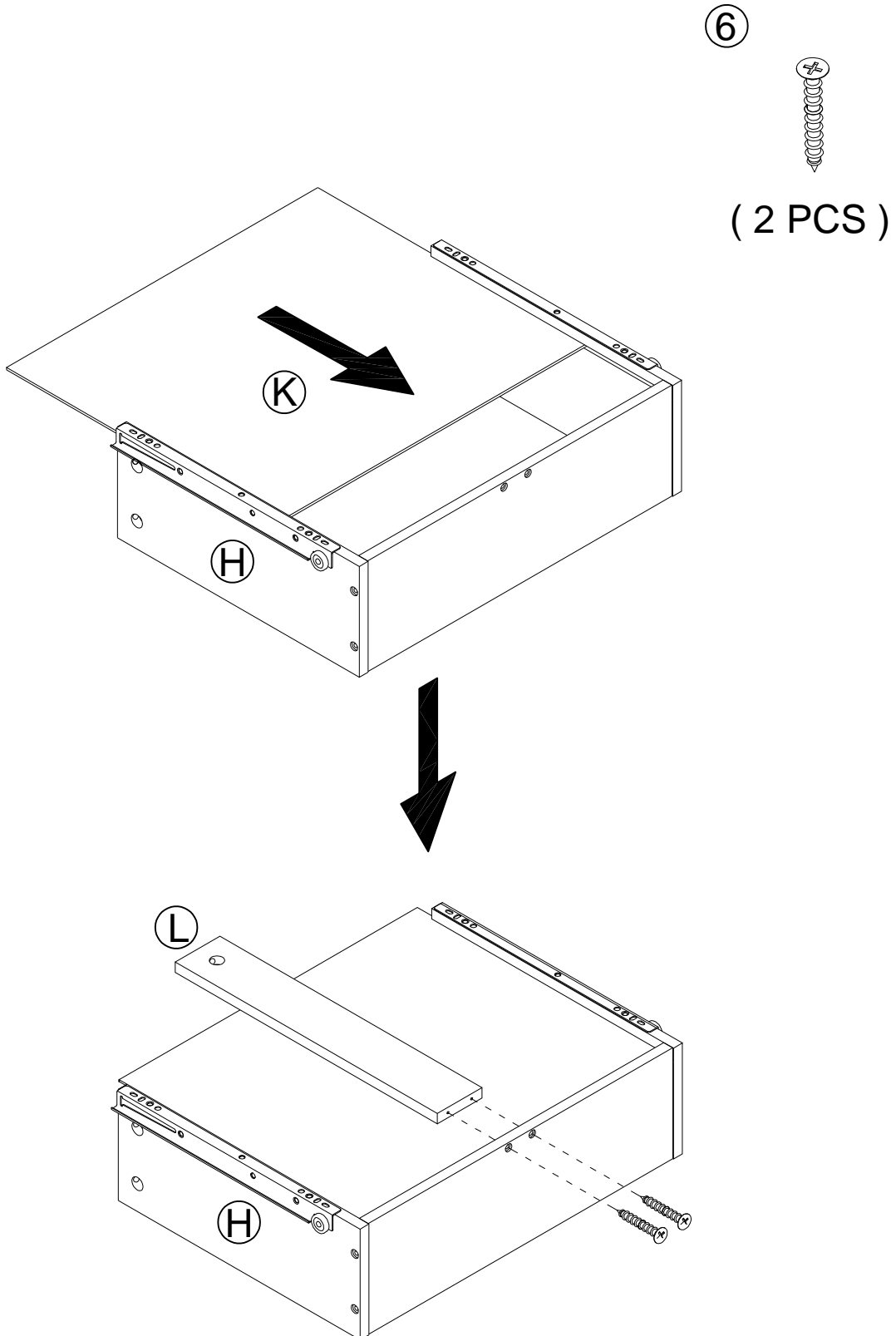

## Step 9:

---

- \* Insert Five KD BOLT (1) to the DRAWER FRONT PANEL (M).
- \* Assemble the HANDLE (N) to the DRAWER FRONT PANEL (M) by the BOLT (9).

①

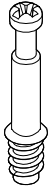

( 5 PCS )

⑨

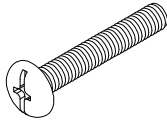

( 2 PCS )

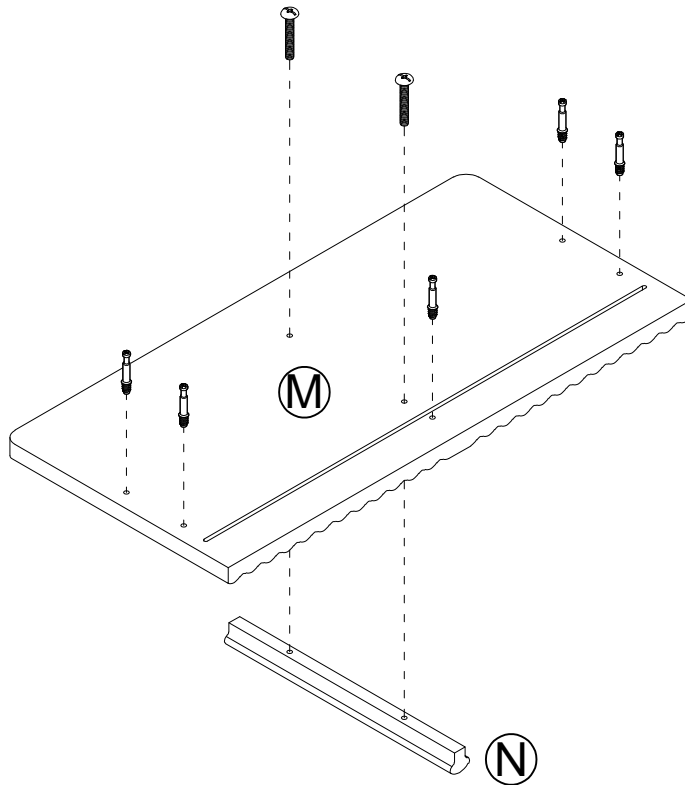

## Step 10:

\* Assemble the DRAWER FRONT PANEL (M) to the DRAWER TRAY by the Five KD SMALL CAM (5) and Five COVER CAP (3).

⑤

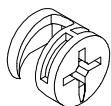

( 5 PCS )

③

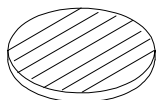

( 5 PCS )

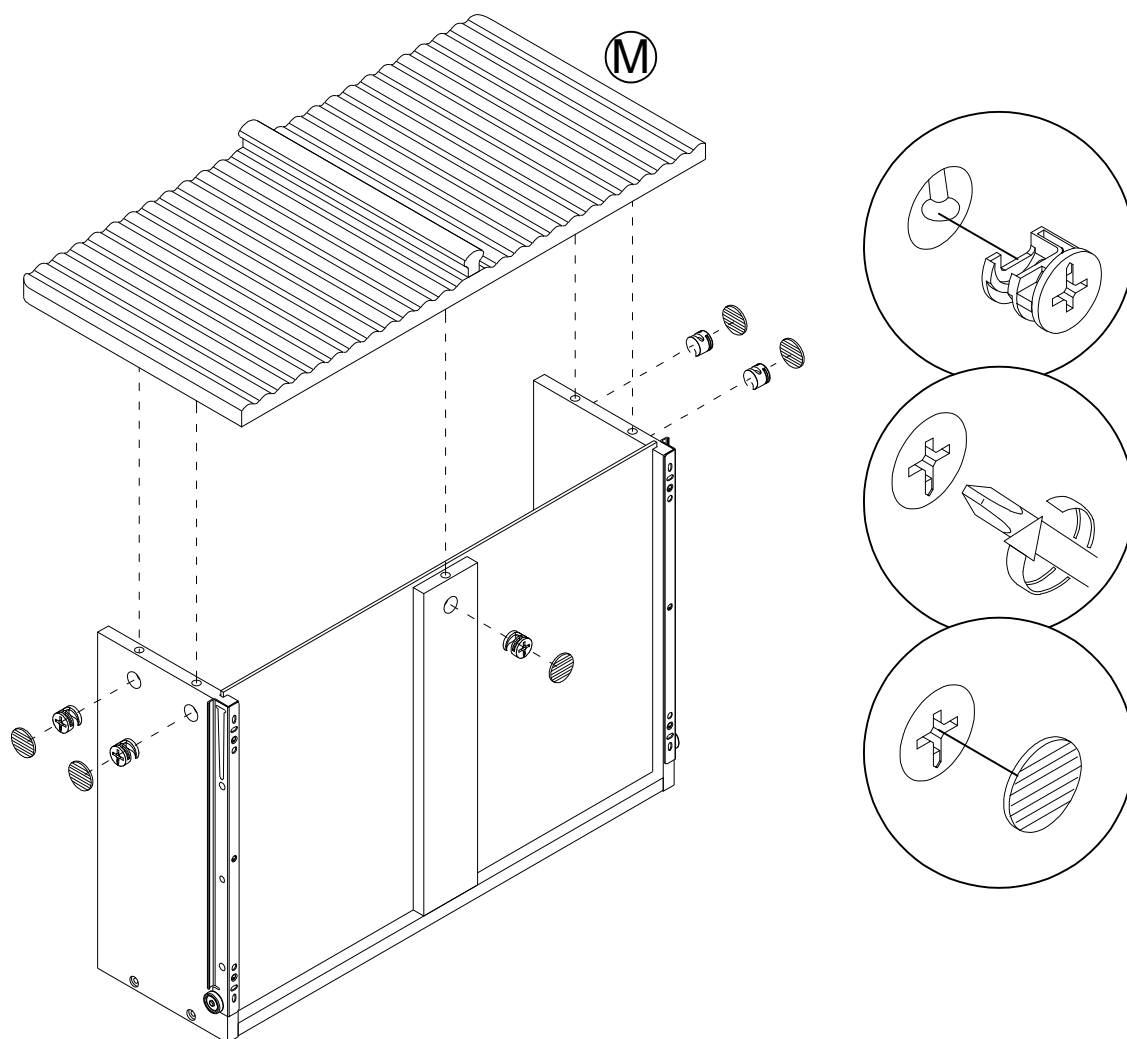

# Step 11:

\*Input Drawer tray to the stand.

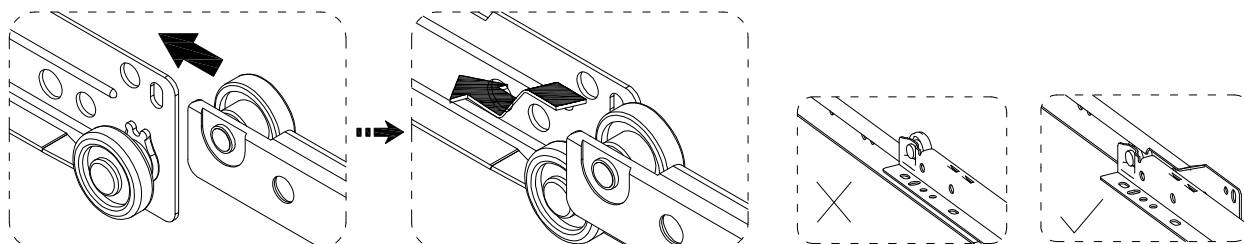
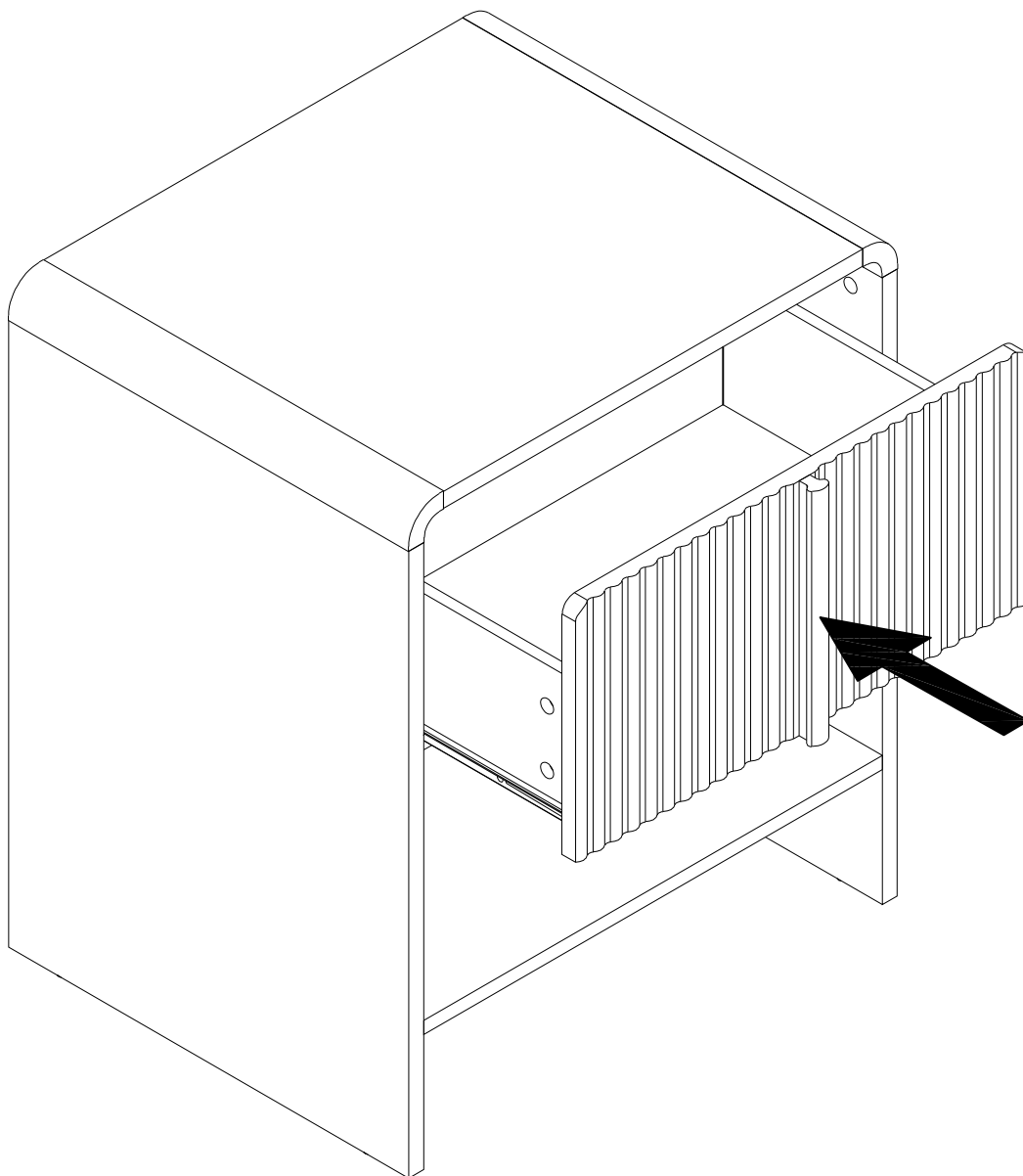



---

## WARRANTY POLICY

All Manhattan Comfort furniture products are warranted, to the original purchaser at the time of purchase and for a period of 30 days thereafter.

Our warranty is limited to new products purchased in factory sealed cartons. This warranty is valid in the United States of America and Canada.

In order to provide you with timely assistance, please thoroughly inspect your furniture for missing or defective parts immediately after opening the carton.

Manhattan Comfort offers a 30-day parts replacement warranty on all items.

Our furniture products are not intended for outdoor use.

### THE WARRANTY DOES NOT COVER:

- Defects/damages by improper assembly or disassembly.
- Defects/damages caused by shipping. Claims for damage during transit should be placed immediately to the transportation company.
- Defects/damages caused by inappropriate use of the furniture.



319 Ridge Rd. Dayton, NJ 08810

908-888-0818