

GAS COOKTOP MANUAL



JZS32003N1



JZS32003N2

⚠ WARNING FIRE OR EXPLOSION HAZARD

If the information in these instructions is not followed exactly, a fire or explosion may result causing property damage, personal injury or death.

Read these instructions completely and carefully.

When installing a gas appliance the use of old flexible connectors can cause gas leaks and personal injury. Always use a new flexible connector.

TOOLS YOU WILL NEED



Phillips screwdriver



Open-end or adjustable wrench



Saber Saw



Flat-blade screwdriver



Pencil and ruler



Pipe wrenches (2) (one for backup)



Safety Glasses



1/8" Drill Bit & Electric or Hand Drill

MATERIALS YOU MAY NEED

- Gas line shut-off valve
- Pipe joint sealant, resists action of natural and propane gases.
- Liquid leak detector or soapy water.
- Installation brackets.

BEFORE YOUR BEGIN

IMPORTANT — Remove all packing and electrical supply to cooktop.

Service — The electrical diagram is located inside the cooktop. Proper installation is the responsibility of the installer.

Product failure due to improper installation is not covered under warranty.

MAINTAIN THE FOLLOWING MINIMUM CLEARANCE DIMENSIONS

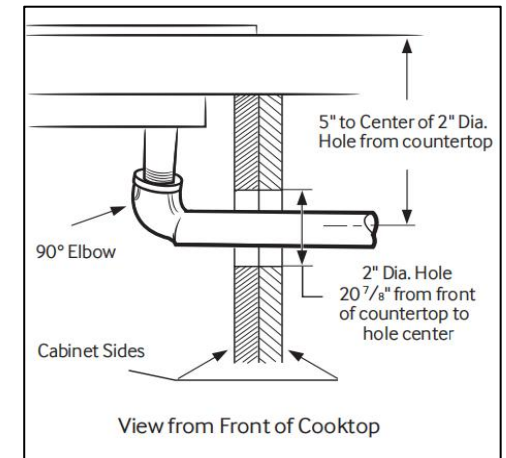
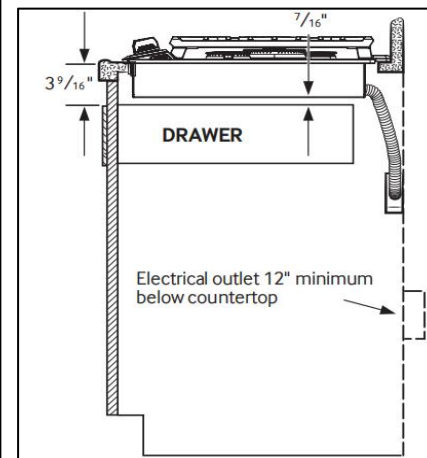
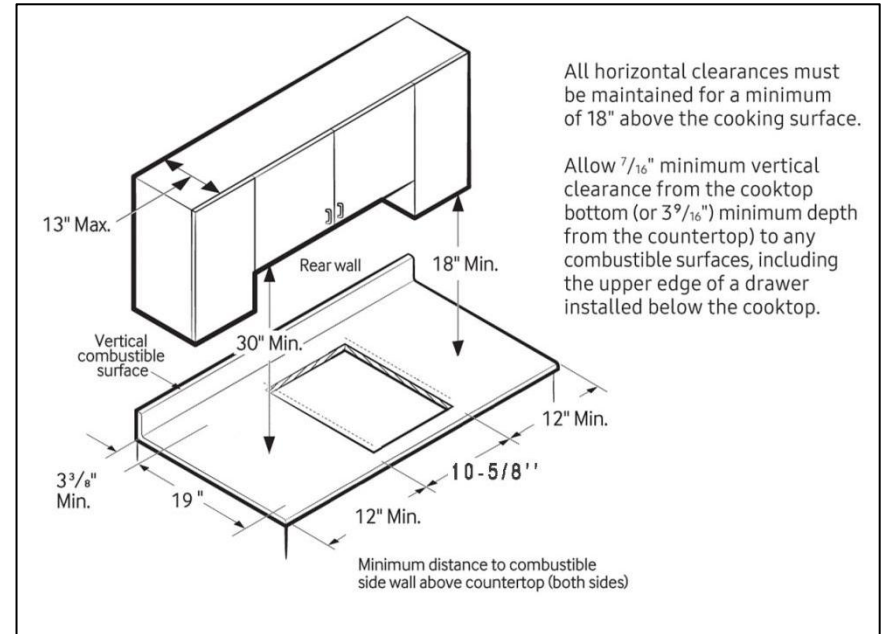

OVERALL COOKTOP DIMENSIONS

12" Models

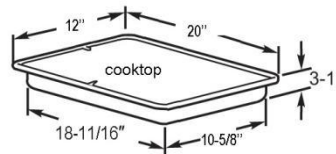

CUTOUT DIMENSIONS OF COUNTERTOP

To ensure accuracy, it is best to make a template when cutting the opening in the counter.

12" Models

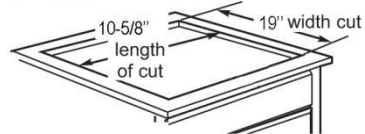

CONVERTING TO PROPANE GAS(OR CONVERTING BACK TO NATURAL GAS FROM PROPANE)

This cooktop leaves the factory set for use with natural gas.

The conversion orifices and instructions can be found attached to the regulator.Keep these instructions and all orifices in case you want to convert back and natural gas.

Take off the burner cap and the aluminum cap, then use suitable instrument for replacing the nozzle "J".

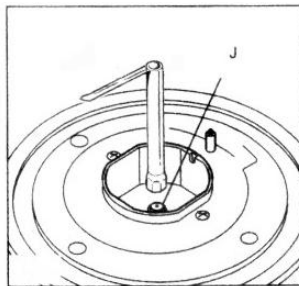

◆ Installing the cooktop

⚠ WARNING

- Locate electric outlet and gas shut-off valve beneath cabinet.
- Insert the cooktop centered into the cutout opening. Make sure the front edge of the countertop is parallel to the cooktop.
- Make final check that all required clearance are met.
- Once the unit is in place screw the cooktop into the cabinet using brackets (not included) to secure the unit into place.

Electric Connections

⚠ WARNING

Shock Hazard: This appliance must be properly

grounded. Failure to do so can result in electric shock.

Electrical Requirements--110-120volt,60Hz,properly grounded circuit protected by a 15-amp or 20-amp circuit breaker or time delay fuse.It is recommended that a separate circuit serving only this cooktop be provided.

NOTE:Use of automatic, wireless, or wired external switches that shut off power to the appliance are not recommended for this product.

Grounding

The power cord of this appliance is equipped with a three-prong(grounding) plug which plugs into a standard three-prong grounding wall receptacle to minimize the possibility of electric shock hazard from this appliance.

The customer should have the wall receptacle and circuit checked by a qualified electrician to make sure the receptacle is properly grounded.

Where a standard two-prong wall receptacle is encountered,it is the personal responsibility and obligation of the customer to have it replaced with a properly grounded three-prong wall receptacle.

DO NOT,UNDER ANY CIRCUMSTANCES,CUT OR REMOVE THE THIRD(GROUND)PRONG FROM THE POWER CORD.DO NOT USE AN ADAPTER.DO NOT USE AN EXTENSION CORD.

Surface Burners

⚠ WARNING

Fire or explosion Hazard:

Do not operate the burner without all burner parts in place.

A. **Burners**-Place surface burners into corresponding positions on cooktop.

B. **Caps**-Place caps on proper size burner

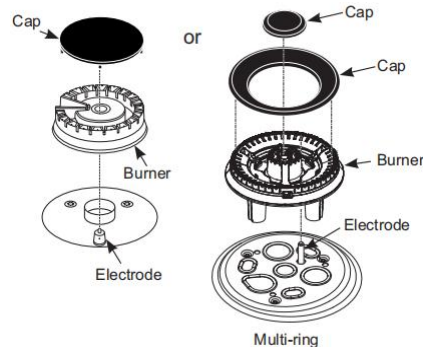

Check Surface

Burners

Push and turn a knob to the IGNITE position.A clicking sound indicates proper operation of the ignition system.When lighting any burner,sparks will appear at all burners but gas flows from only the one selected.Once air is purged from the supply line,burner should light within 4 seconds.After burner lights,rotate the knob out of the IGNITE position.Try each burner in succession until all burners have been checked.

Quality of Flames

Determine the quality of flames visually.Normal burner flames should look like(A) or (B).

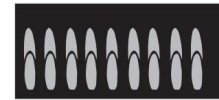

(A)Soft blue flames-
Normal for natural
gas

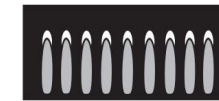

(B)Yellow tips on
outer cones-
Normal for propane
gas

Long,bright yellow flames are not normal.Normal flames may show signs of an orange tint when well heated or signs of flickering orange due to particles in the gas or air.

WHEN ALL HOOKUPS ARE COMPLETED

Make sure all controls are left in the off position.Make sure the flow of combustion and ventilation air to the cooktop is unobstructed.

Check that all packing materials and tape have been removed.This will include adhesive tape,wire ties,cardboard and protective plastic.

Failure to remove these materials could result in damage to the appliance once the appliance have been turned on and surfaces have heated.

Warning!!!

The timer is only used as a reminder function and does not cut off the gas. Please close the valve in time after the bell rings !

Adapting To Different Types of Gas

Before carrying out any maintenance work, disconnect the appliance from the gas and electric supply.

To change the nozzles of burners use the following procedure:

Lift up the burners and unscrew the nozzles using an adjustable spanner of 7mm and change the nozzles (Picture "J") with those designed for the new gas supply according to the information shown below.

ATTENTION: After carrying out the changes described above, the technician must put the card corresponding to the new gas supply on the appliance to take the place. This card is found in the bag containing spare nozzles.

Burner	Type of Gas	Pressure/mbar	Nozzle Diameter 1/100mm
Auxiliary	Natural 20	20	85
	Butane 30	30	53
Semi-Rapid	Natural 20	20	110
	Butane 30	30	69
Rapid	Natural 20	20	145
	Butane 30	30	90
Triple-ring	Natural 20	20	170
	Butane 30	30	109

Recommended Pan Diameters

BURNER	PAN DIAMETERS Recommended(cm.)
Auxiliary	12-14
Semi-Rapid	14-26
Rapid	18-26
Triple-ring	22-26

Matters Needing Attention

- A. Before installation, along the inside of the four edges of the cooktop, paste sponge strips to buffer the friction between the cooktop and the cabinet panel.
- B. Ignition: If there is no electric current you can light the burners with matches.
- C. When cooking food with oil or fat which can easily set alight, the user must not leave the cooktop. Do not use sprays near the cooktop when it is in use. When using the burners make sure that the pan handles are in the correct position.
- D. Keep children away.
- E. Before carrying out any cleaning operation disconnect the cooktop from the electric mains and turn off the main tap which supplies the cooktop with gas.
- F. Choose the right pan size:

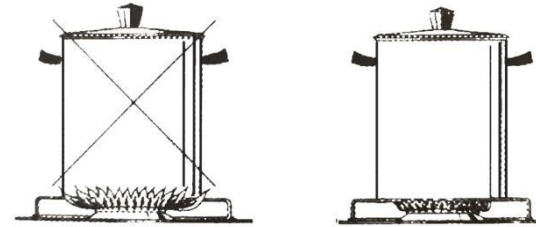

- G. Choose flat pan:

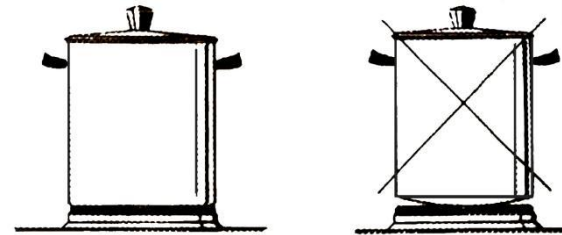

- H. Cleaning the worktop: periodically the burner heads, enameled steel grills, enameled lids and flame dividers must be cleaned with warm soapy water, rinsed and dried well.
- I. Any liquid which overflows from the pan must always be removed with a cloth.
- J. If opening or closing any tap is difficult do not force it but ask for an urgent check from the technical assistant.

K. Cleaning of the enameled parts:to maintain the features of the enameled parts they must be cleaned frequently with soapy water.Never use the abrasive powders.Avoid leaving acid or alkaline substances on the enameled parts(vinegar,lemon juice,salt,tomato juice etc.) and washing the enameled parts when they are still warm.

L. Cleaning of the stainless steel parts:clean the parts with soapy water and then dry them with a soft cloth.the shininess is maintained by periodically cleaning with the special products normally available on the market.Never use abrasive powders.

M. Cleaning the burner flame dividers:as they are not fixed,the flame dividers can be cleaned by simply removing them and cleaning with soapy water.After drying them well and checking that the holes are not blocked,put them back into their correct position.

N.After clean,put the burner flame dividers back into their correct position:

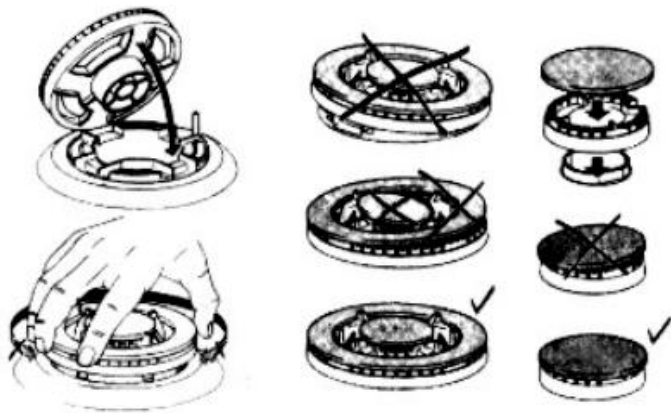

Packing list:

* Gas Cooktop body	1 pcs
* Burner cap	1 set(2 pcs)
* Pan Support	1 set(1 pcs)
* Foot	1 set(4 pcs)
* LPG Nozzles	1 set(2 pcs)
* 1/2" Tracheal connector+Rubber gasket	1 set
* 5/8" copper adapter	1 set(2 pcs)
* 7mm Socket Wrench	1 pcs
* The Sponge article	1 roll
* Manual book	1 pcs