

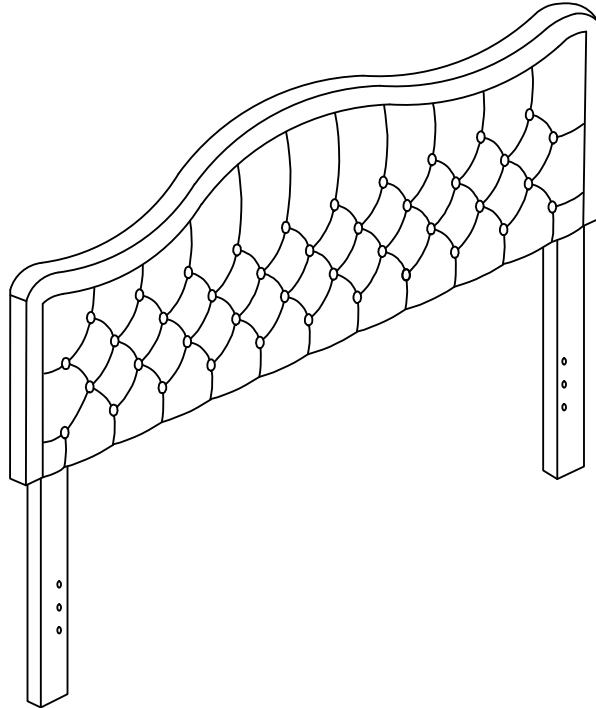

**ALTON FURNITURE GROUP**

A RENOWNED NAME  
— FURNISH A BETTER LIFE —



**Item: A3H-K,Q,F,T**

### **Quality statement**

Alton Furniture Group appreciates your selection of our product. Through our detailed quality checks, we ensure that each box contains exceptional components that will exceed your expectations.

### **Customer Service**

If your order has missing parts or defective items or if you have any questions, please do not hesitate to contact our customer service department at 1-866-558-0211 between 8:00am to 5:00pm (PDT), Monday through Friday, or email us at [info@altonfurniture.com](mailto:info@altonfurniture.com)

### **Care Instructions**

Please follow the instructions provided below for proper care of your product. Following these tips will ensure your furniture's high-standard quality remains as it ages

- Vacuum regularly to eliminate dust as they can be abrasive and wear the furniture prematurely
- Never use harsh chemicals or solvents as this may damage the finish
- Limit contact with liquids as this may damage the finish
- Bolt spills immediately to prevent staining. If necessary, gently wipe using a clean cloth dampened with warm water. Proceed to brush lightly after drying
- If you choose to use a professional product, test the fabric in a discreet area for any signs of defect
- Stains from markers, pens, crayons, and pens may be difficult to remove. We recommend that you consult a professional



**ALTON FURNITURE GROUP**

A RENOWNED NAME  
FURNISH A BETTER LIFE

## PARTS LIST

**PLEASE CHECK TO ENSURE ALL PARTS ARE IN THE BOX**

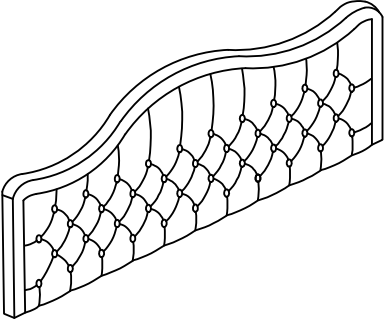
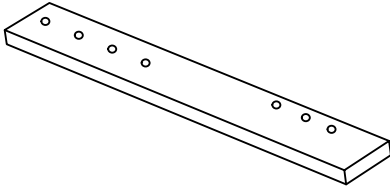
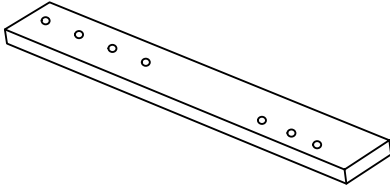
A	1PC	L	1PC	R	1PC
Headboard Panel		Left Headboard leg		Right Headboard leg	
					

## HARDWARE LIST

**PLEASE CHECK TO ENSURE ALL PARTS ARE IN THE BOX**

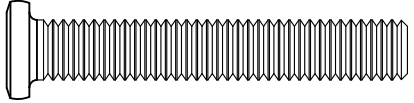
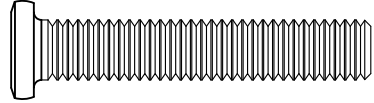
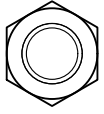
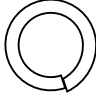
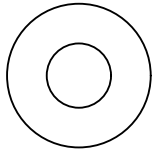
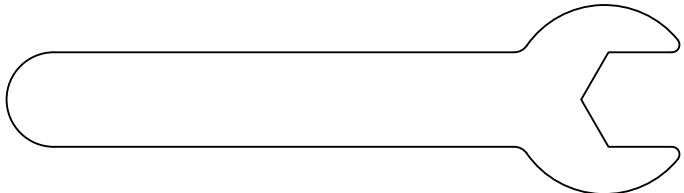
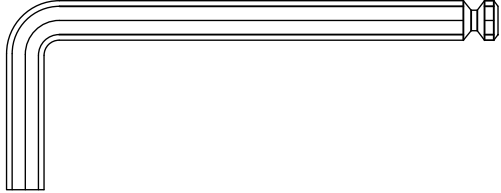
①	4PCS	②	4PCS		
Allen Bolts 5/16" x 2"		Allen Bolts 5/16" x 1-3/4"			
					
③	4PCS	④	8PCS	⑤	12PCS
Nuts		Spring Washers $\text{Ø}5/16'' \times \text{Ø}9/16''$		Flat Washers $\text{Ø}5/16'' \times \text{Ø}3/4''$	
					
⑥	1PC	⑦	1PC		
Wrench		Allen Wrench M5 x 2-1/2"			
					



**ALTON FURNITURE GROUP**

A RENOWNED NAME  
FURNISH A BETTER LIFE

## IMPORTANT !!

Tips:

**\*\*Please check the thickness of your mattress and box spring before proceeding.**

1)



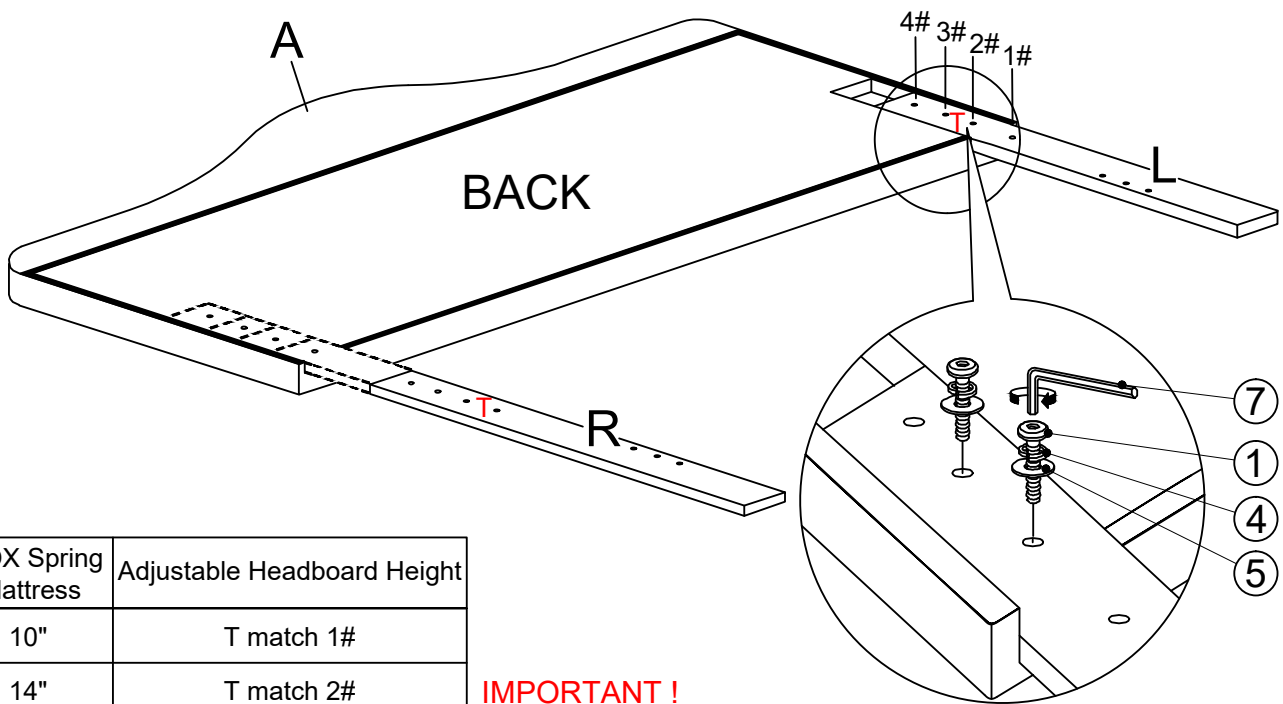

Assemble the Headboard Panel (A) and the Legs (R & L).

(DO NOT FULLY TIGHTEN BOLTS AT THIS STEP.)

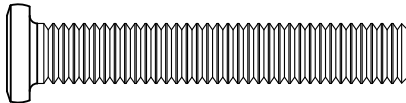

BOX Spring +Mattress	Adjustable Headboard Height
10"	T match 1#
14"	T match 2#
18"	T match 3#
22"	T match 4#

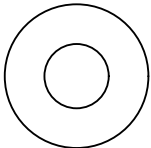
**IMPORTANT !**  
Please check the thickness of your mattress and box spring before proceeding.

①	4PCS	④	4PCS
Allen Bolts 5/16" x 2"		Spring Washers Ø5/16" x Ø9/16"	
			
⑤	4PCS	⑦	1PC
Flat Washers Ø5/16" x Ø3/4"		Allen Wrench M5 x 2-1/2"	
			



**ALTON FURNITURE GROUP**

A RENOWNED NAME  
FURNISH A BETTER LIFE

2)  
Assemble the metal bed frame (not included) to headboard legs (L/R).

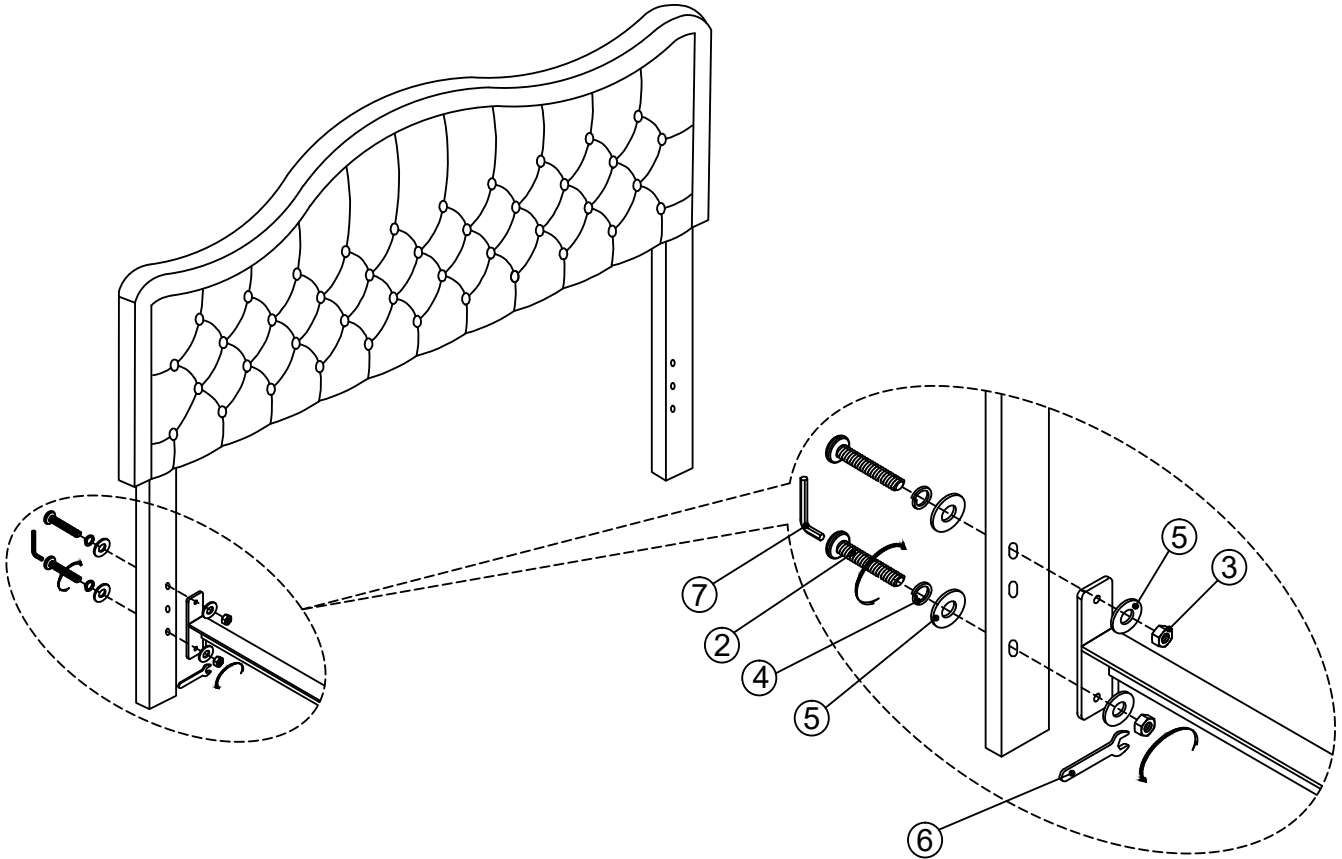

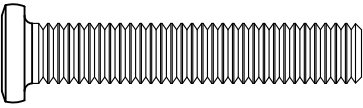
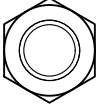
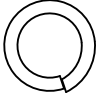
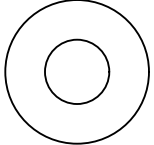
②	4PCS	③	4PCS	④	4PCS	⑤	8PCS
Allen Bolts 5/16" x1-3/4"		Nuts		Spring Washers Ø5/16" x Ø9/16"		Flat Washers Ø5/16" x Ø3/4"	
							
⑥		1PC		⑦		1PC	
Wrench				Allen Wrench M5 x 2-1/2"			
