

ASSEMBLY INSTRUCTIONS

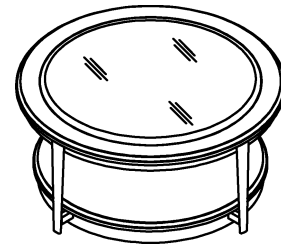

473-911

TOOLS REQUIRED:

- Allen Wrench (Provided, Part H)
- Screwdriver (Not Provided)

BEFORE YOU START:

1. Check the hardwares against the hardware list to make sure all items are present.
2. Assemble your furniture on a soft, flat surface to avoid scratching the finish.
3. **CAUTION:** Do not over tighten screws, nuts or bolts during assembly.
4. Your furniture may require occasional tightening.

INSTRUCTIONS:

1. Attach L-shaped metal bracket (I) to table leg, tighten Countersunk Bolt (A) by using Allen Wrench (H) as shown in Figure 1.
2. Attach table leg to bottom panel, tighten Bolt (B), Lock Washer (C) and Flat Washer (D) by using Allen Wrench (H) as shown in Figure 2.
3. Turn the table top frame upside down on to a clean, soft surface. Attach the assembly to the top frame, tighten Bolt (E), Lock Washer (F) and Flat Washer (G) by using Allen Wrench (H). Cover the bolt holes by plastic cap (L) as shown in Figure 3.
4. Attach the casters (K) to bottom panel using screw (J) as shown in Figure 4.
5. Turn the table upright and carefully place the glass top to the top frame as show in Figure 5.

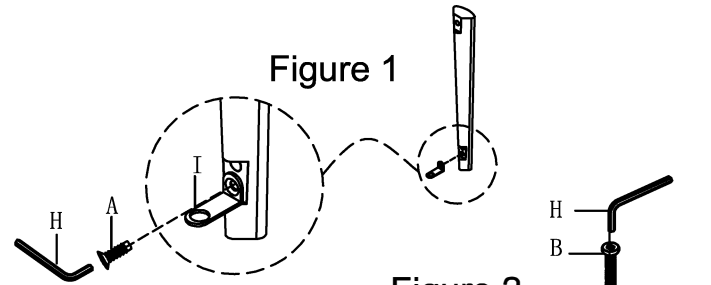

Figure 1

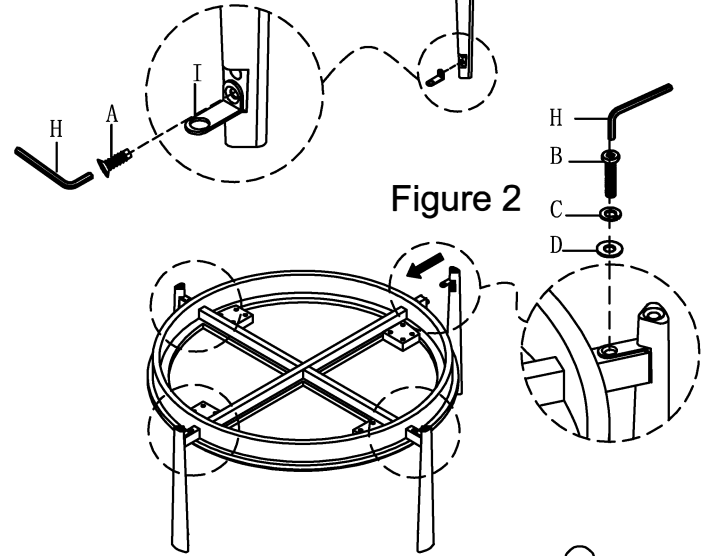

Figure 2

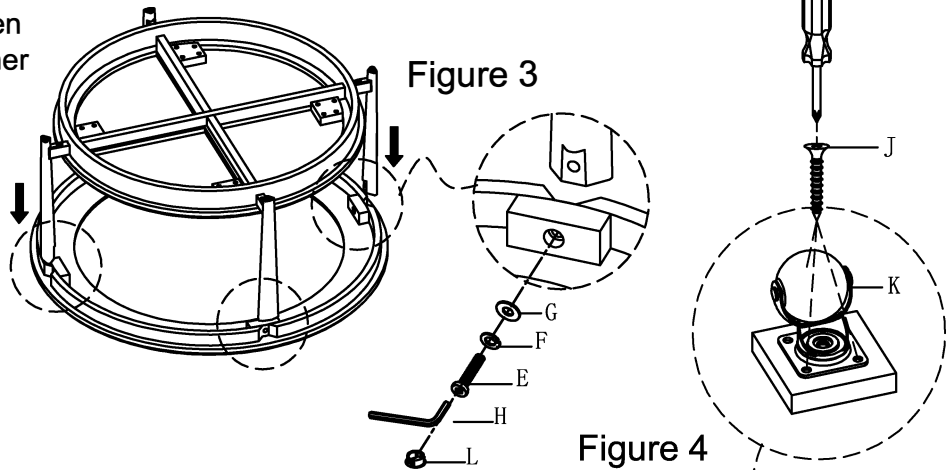

Figure 3

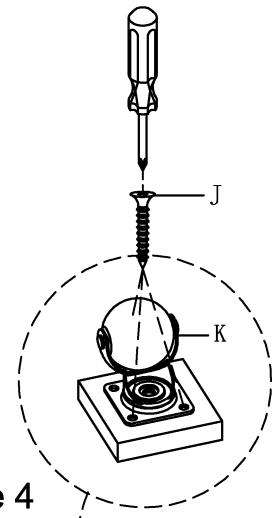

Figure 4

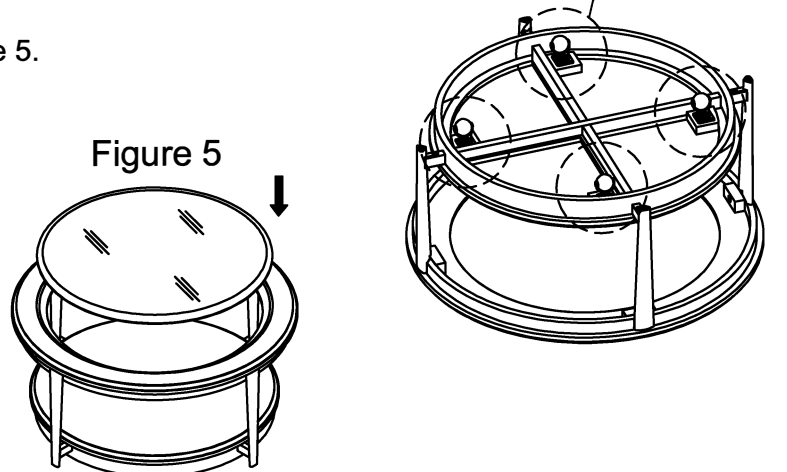

Figure 5

No.	HARDWARE LIST		Q'ty
A		Countersunk Bolt (Ø1/4"x5/8")	4pcs
B		Bolt (Ø1/4"x5/8")	4pcs
C		Lock Washer (Ø1/4")	4pcs
D		Flat Washer (Ø1/4"*16*1.5mm)	4pcs
E		Bolt (Ø5/16"x1 3/4")	4pcs
F		Lock Washer (Ø5/16")	4pcs
G		Flat Washer (Ø5/16"*16*1.5mm)	4pcs
H		Allen Wrench (100*50*4mm)	1pc
I		L-shaped metal bracket (42*20*16*2mm)	4pcs
J		Screw (Ø8x5/8")	16pcs
K		Caster (Ø50*H64mm)	4pcs
L		Plastic Cap (3/4")	4pcs