

# ASSEMBLY INSTRUCTIONS

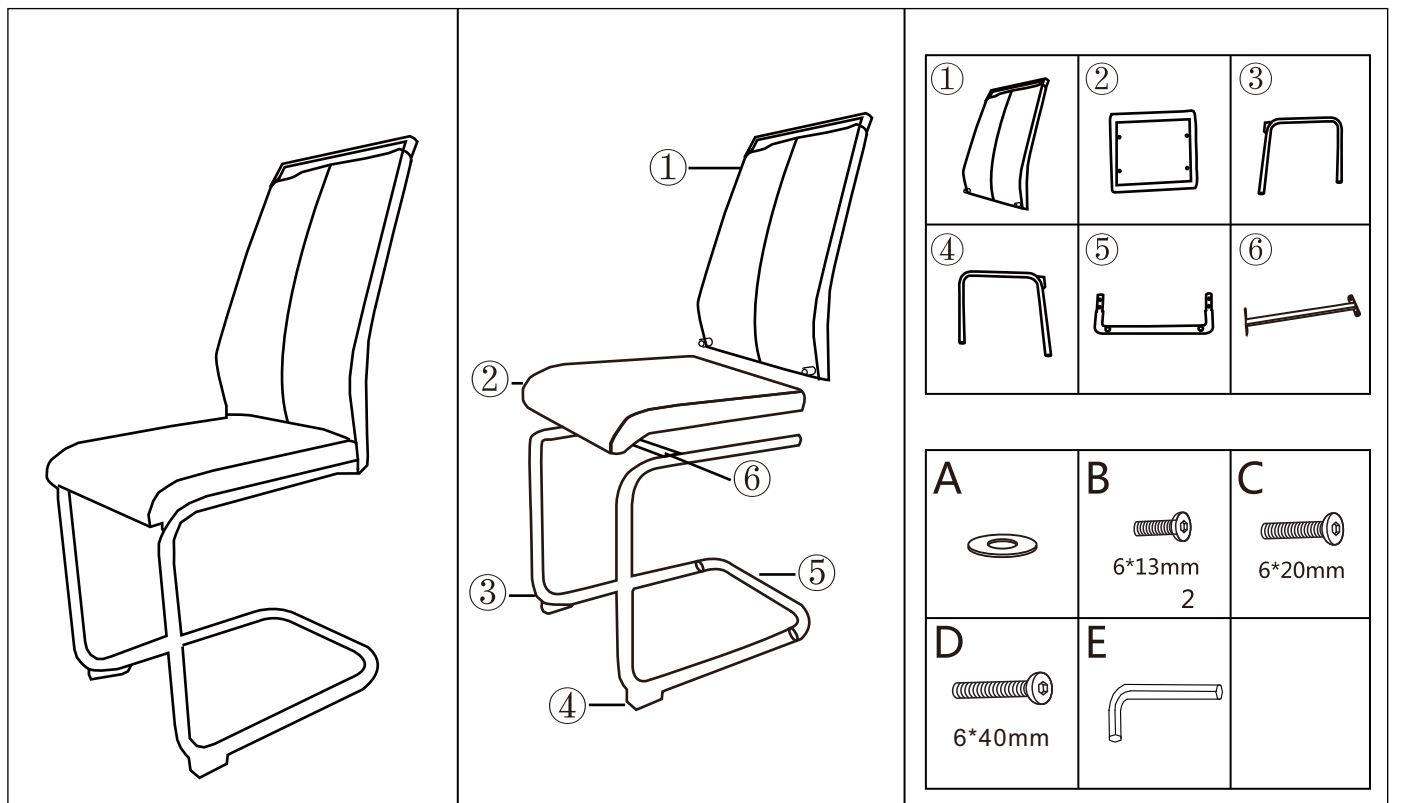

**STEP 1** ③ and ④ are connected to ⑤ respectively, ⑥ is connected to ③ and ④, B is inserted into the corresponding hole and fastened with E.

Bx8  
Ex1

**STEP 2** Connect ① to ③ and ④ respectively, insert B into the corresponding hole and tighten with E.

Bx4  
Ex1

**STEP 3** Connect ② to ③ and ④ respectively, fit C, A and D, A to the corresponding holes in turn and tighten C and D with E.

Ax4  
Cx2  
Dx2  
Ex1

**STEP 4** Installation complete