

# ASSEMBLY INSTRUCTIONS

INSTRUCTIONS DE MONTAGE

## FULL LOFT BED WITH DESK, SHELVES

LIT LOFT COMPLET AVEC BUREAU, ÉTAGÈRES

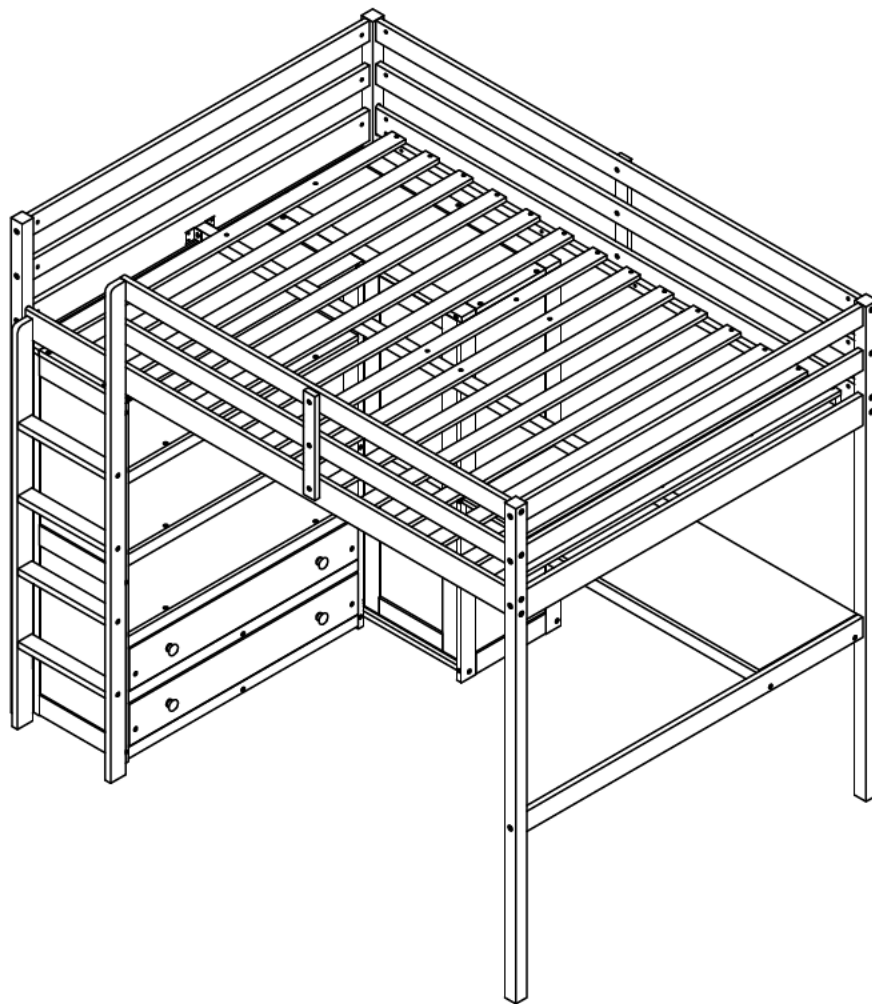

## SAFETY WARNINGS AND GENERAL NOTES:

Follow the information on the warnings on the bunk bed end structure and on the carton. Do not remove the warning label from the bed. Always use the recommended size mattress on mattress support, or both, to help prevent the likelihood of entrapment or falls.

The top surface of the mattress must be at least 5\*inch (127mm) below the upper edge of the guardrail.

Do not allow children under 6 years of age to use the upper bunk.

Periodically check and ensure the guardrail, ladder and other components are in their proper position, free from damage, and all connectors are tight.

Do not allow horseplay on or under beds.

Always prohibit jumping on the bed.

Prohibit more than one person on upper bunk.

Always use the ladder for entering and leaving the upper bunk.

Do not use substitute parts. Contact the manufacturer or dealer for replacement parts.

Use of a night-light may provide added safety precaution for a child using the upper bunk.

Always use guardrails on both long sides of the upper bunk.

If the bunk bed will be placed next to a wall, the guardrail that runs the full length of the bed should be placed against the wall to prevent entrapment between the bed and the wall.

The use of water or sleep flotation mattresses is prohibited.

**STRANGULATION HAZARD**-Never attach or hang items to any part of the bunk bed that are not designed for use with the bed.

Keep these instructions for future reference.

We recommend assembling your bunk bed on the shipping carton to protect your floor or carpet.

Be certain all staples are out of the box before beginning assembly on the shipping carton.

**THIS BED IS DESIGNED TO USE A FULL MATTRESSES 54" WIDE X 74"-75" LONG WITH THE TOTAL THICKNESS NOT EXCEEDING 6" FOR UPPER BUNK, SURFACE OF MATTRESS MUST BE AT LEAST 5" (127MM) BELOW THE UPPER EDGE OF GUARDRAILS.**

Replacement Parts:

Replacement Parts, including additional guardrails, may be obtained from any of our

## AVERTISSEMENTS DE SÉCURITÉ ET REMARQUES GÉNÉRALES :

Suivez les informations sur les avertissements figurant sur la structure d'extrémité du lit superposé et sur le carton. Ne retirez pas l'étiquette d'avertissement du lit. Utilisez toujours le matelas de taille recommandée sur le support de matelas, ou les deux, pour éviter tout risque de coincement ou de chute.

La surface supérieure du matelas doit être à au moins 5\*poûces (127 mm) sous le bord supérieur du garde-corps.

Ne laissez pas les enfants de moins de 6 ans utiliser le lit supérieur.

Vérifiez périodiquement et assurez-vous que le garde-corps, l'échelle et les autres composants sont dans leur bonne position, exempts de dommages et que tous les connecteurs sont bien serrés.

Ne permettez pas les chahuts sur ou sous les lits.

Interdisez toujours de sauter sur le lit.

Interdire plus d'une personne sur la couchette supérieure.

Utilisez toujours l'échelle pour entrer et sortir du lit supérieur.

N'utilisez pas de pièces de rechange. Contactez le fabricant ou le revendeur pour obtenir des pièces de rechange.

L'utilisation d'une veilleuse peut fournir une précaution supplémentaire en matière de sécurité pour un enfant utilisant le lit supérieur.

Utilisez toujours des garde-corps sur les deux côtés longs du lit supérieur.

Si le lit superposé doit être placé à côté d'un mur, le garde-corps qui s'étend sur toute la longueur du lit doit être placé contre le mur pour éviter tout coincement entre le lit et le mur.

L'utilisation de matelas flottants à eau ou de sommeil est interdite.

**RISQUE D'ÉTRANGULATION** - N'attachez ou ne suspendez jamais d'objets à une partie du lit superposé qui ne sont pas conçus pour être utilisés avec le lit.

Conservez ces instructions pour référence future.

Nous vous recommandons d'assembler votre lit superposé sur le carton d'expédition pour protéger votre sol ou votre tapis.

Assurez-vous que toutes les agrafes sont sorties de la boîte avant de commencer l'assemblage sur le carton d'expédition.

**CE LIT EST CONÇU POUR UTILISER UN MATELAS COMPLET DE 54" DE LARGE X 74" - 75" DE LONG AVEC L'ÉPAISSEUR TOTALE NE DÉPASSANT PAS 6" POUR LE COUCHE SUPÉRIEUR, LA SURFACE DU MATELAS DOIT ÊTRE AU MOINS 5" (127 MM) EN DESSOUS DU BORD SUPÉRIEUR DES GARDE-CORPS.**

Pièces de rechange :

Les pièces de rechange, y compris les garde-corps supplémentaires, peuvent être obtenues auprès de l'un de nos revendeurs





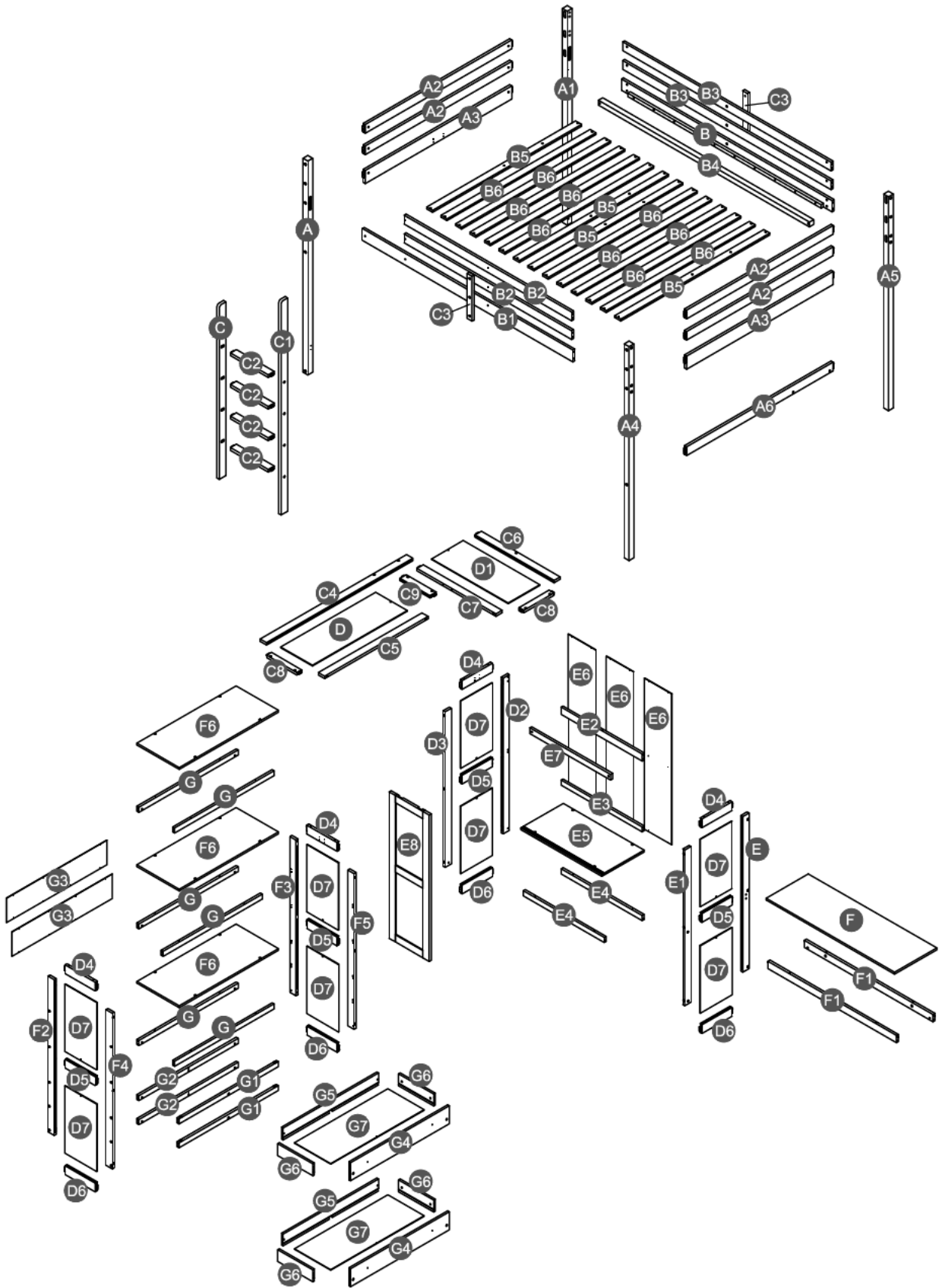







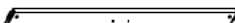













# Detail View







## Vue Détaillée

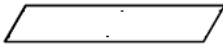

# Part list



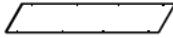
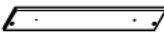









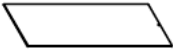
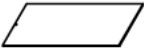

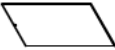



Liste des pièces

<p><b>A</b></p>  <p>Leg (Left front ) - 1pc Pied (Avant gauche)</p>	<p><b>A1</b></p>  <p>Leg (Left back ) - 1pc Pied (Arrière gauche)</p>	<p><b>A2</b></p>  <p>Upper horizontal bar HB/FB- 4pcs Barre horizontale supérieur HB/FB</p>
<p><b>A3</b></p>  <p>Divider horizontal bar HB/FB- 2pcs Barre de séparation horizontale HB/FB</p>	<p><b>A4</b></p>  <p>Leg (Right front ) - 1pc Pied (Avant droit)</p>	<p><b>A5</b></p>  <p>Leg (Right back ) - 1pc Pied (arrière droit)</p>
<p><b>A6</b></p>  <p>Lower horizontal bar HB - 1pc Barre horizontale inférieure HB</p>	<p><b>B</b></p>  <p>Upper side rail (Back) - 1pc Rail latéral supérieur (Arrière)</p>	<p><b>B1</b></p>  <p>Upper side rail (Front) - 1pc Rail latéral supérieur (Avant)</p>
<p><b>B2</b></p>  <p>Short guard rail (Front) - 2pcs Garde-corps court (avant)</p>	<p><b>B3</b></p>  <p>Long guard rail (Back) - 2pcs Garde-corps long (Arrière)</p>	<p><b>B4</b></p>  <p>Lower support slat - 1pc Latte de support inférieure</p>
<p><b>C</b></p>  <p>Ladder (left) - 1pc Échelle (gauche)</p>	<p><b>C1</b></p>  <p>Ladder (right) - 1pc Échelle (droite)</p>	<p><b>C2</b></p>  <p>Step ladder - 4pcs Escabeau</p>
<p><b>C3</b></p>  <p>Vertical guard rail - 2pcs Garde-corps vertical</p>	<p><b>C4</b></p>  <p>Upper horizontal bar (Back) - 1pc Barre horizontale supérieure (Arrière)</p>	<p><b>C5</b></p>  <p>Upper horizontal bar (Front) - 1pc Barre horizontale supérieure (avant)</p>
<p><b>C6</b></p>  <p>Upper horizontal bar (right) - 1pc Barre horizontale supérieure (droit)</p>	<p><b>C7</b></p>  <p>Upper horizontal bar (left) - 1pc Barre horizontale supérieure (gauche)</p>	<p><b>C8</b></p>  <p>Upper horizontal bar - 2pcs Barre horizontale supérieure</p>
<p><b>C9</b></p>  <p>Upper divider horizontal bar- 1pc Barre horizontale de séparation supérieure</p>	<p><b>D4</b></p>  <p>Upper horizontal bar - 4pcs Barre horizontale supérieur</p>	<p><b>D5</b></p>  <p>Divider horizontal bar - 4pcs Barre de séparation horizontale</p>
<p><b>D6</b></p>  <p>Lower horizontal bar - 4pcs Barre horizontale inférieure</p>	<p><b>E2</b></p>  <p>Upper horizontal bar (back) - 1pc Barre horizontale supérieur (arrière)</p>	<p><b>E3</b></p>  <p>Divider horizontal bar (back) - 1pc Barre de séparation horizontale (arrière)</p>

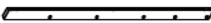
<b>E4</b>  Lower horizontal bar - 2pcs Barre horizontale inférieure	<b>E6</b>  Back panel - 3pcs Panneau arrière	<b>G</b>  Upper horizontal bar - 6pcs Barre horizontale supérieur
<b>G1</b>  Lower horizontal bar (front) - 2pcs Barre horizontale inférieure (avant)	<b>G2</b>  Lower horizontal bar (back) - 2pcs Barre horizontale inférieure (arrière)	<b>G3</b>  Back panel - 2pcs Panneau arrière
<b>G4</b>  Front drawer panel - 2pcs Panneau de tiroir avant	<b>G5</b>  Back drawer panel - 2pcs Panneau de tiroir arrière	<b>G6</b>  Left / right drawer panel - 4pcs Panneau de tiroir gauche/droit











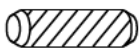

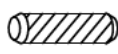
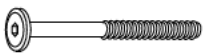
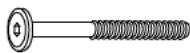
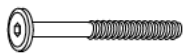







# Part list & Hardware list







Liste des pièces & liste du matériel

<p><b>B5</b></p>  <p>Slat - 4pcs Latte</p>	<p><b>B6</b></p>  <p>Slat - 10pcs Latte</p>	<p><b>D</b></p>  <p>Upper panel (Left) - 1pc Panneau supérieur (gauche)</p>
<p><b>D1</b></p>  <p>Upper panel (Right) - 1pc Panneau supérieur (droite)</p>	<p><b>D2</b></p>  <p>Vertical bar (Left Back) - 1pc Barre verticale (Arrière gauche)</p>	<p><b>D3</b></p>  <p>Vertical bar (Left Front) - 1pc Barre verticale (Avant gauche)</p>
<p><b>D7</b></p>  <p>Side panel - 8pcs Panneau latéral</p>	<p><b>E</b></p>  <p>Leg (Right back) - 1pc Pied (arrière droit)</p>	<p><b>E1</b></p>  <p>Leg (Right front) - 1pc Pied (Avant droit)</p>
<p><b>E5</b></p>  <p>Bottom panel - 1pc Panneau inférieur</p>	<p><b>E7</b></p>  <p>Hanging bar - 1pc Barre de suspension</p>	<p><b>E8</b></p>  <p>Door sliding - 1pc Porte coulissante</p>
<p><b>F</b></p>  <p>Top table - 1pc Table haute</p>	<p><b>F1</b></p>  <p>Horizontal bar - 2pcs Barre horizontale</p>	<p><b>F2</b></p>  <p>Vertical bar (Left Back) - 1pc Barre verticale (Arrière gauche)</p>
<p><b>F3</b></p>  <p>Leg (Right back) - 1pc Pied (arrière droit)</p>	<p><b>F4</b></p>  <p>Vertical bar (Left Front) - 1pc Barre verticale (Avant gauche)</p>	<p><b>F5</b></p>  <p>Leg (Right front) - 1pc Pied (Avant droit)</p>
<p><b>F6</b></p>  <p>Shelf panel - 3pcs Panneau d'étagère</p>	<p><b>G7</b></p>  <p>Drawer bottom - 2pcs Fond de tiroir</p>	

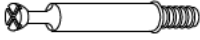
# Hardware List

## Liste du matériel

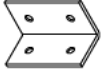
<b>1</b>	 Ø10*40mm Wood dowel (6pcs) Cheville en bois	<b>2</b>	 Ø10*20mm Wood dowel (1pc) Cheville en bois	<b>3</b>	 Ø8*30mm Wood dowel (36pcs) Cheville en bois
<b>4</b>	 (Ø15)1/4"*100mm Hex-Head bolts (16pcs) Boulons à tête hexagonale	<b>5</b>	 (Ø15)1/4"*80mm Hex-Head bolts (14pcs) Boulons à tête hexagonale	<b>6</b>	 (Ø12)1/4"*60mm Hex-Head bolts (50pcs) Boulons à tête hexagonale
<b>7</b>	 (Ø12)1/4"*40mm Hex-Head bolts (6pcs) Boulons à tête hexagonale	<b>8</b>	 (Ø12)1/4"*30mm Hex-Head bolts (6pcs) Boulons à tête hexagonale	<b>9</b>	 (Ø12)1/4"*15mm Hex-Head bolts (2pcs) Boulons à tête hexagonale
<b>10</b>	 1/4"*15 (9.5mm) Horizontal-Hole bolts(80pcs) Boulons à trou horizontal	<b>11</b>	 Ø4*30mm Wood screws (32pcs) Vis	<b>12</b>	 (1/4")4.5*58mm Allen key (2pcs) Clé Allen
<b>13</b>	 Ø3.5*19mm Wood screws (8pcs) Vis	<b>14</b>	 Ø3.5*15mm Wood screws (38pcs) Vis	<b>15</b>	 Ø3.5*15mm Wood screws (32pcs) Vis
<b>16</b>	 (Ø12)1/4"*65mm Hex-Head bolts (32pcs) Boulons à tête hexagonale	<b>17</b>	 (Ø12)1/4"*40mm Hex-Head bolts (25pcs) Boulons à tête hexagonale	<b>18</b>	 (Ø13)1/4"*14mm Connect bolt (4pcs) Connecter le boulon
<b>19</b>	 Ø38*31mm Pine Knob (4pcs) Bouton en pin	<b>20</b>	 3/16"*25mm Ph zinc(Knob) (4pcs) Ph zinc (bouton)	<b>21</b>	 116*40*27mm Metal bracket (2pcs) Support métallique
<b>22</b>	 63*40*30*1.2mm Metal bracket (2pcs) Support métallique	<b>23</b>	 365*58*28 mm Lower slider drawer (2pcs) Tiroir coulissant inférieur	<b>24</b>	 340*30mm Upper slider drawer (2pcs) Tiroir coulissant supérieur

<b>25</b>  Ø7"*35mm Cam lock (5pcs) Serrure à came	<b>26</b>  Ø14*9mm Cam lock (5pcs) Serrure à came	<b>27</b>  L58*51*12mm Sliding wheel (2pcs) Roue coulissante
<b>28</b>  L58*51*12mm Sliding wheel (2pcs) Roue coulissante	<b>29</b>  50*24*24*2mm Metal bracket (1pc) Support métallique	<b>30</b>  24*28*28*2mm Metal bracket (2pcs) Support métallique

**ASSEMBLY TOOLS REQUIRED ( NOT INCLUDED )**  
**OUTILS D'ASSEMBLAGE REQUIS (NON INCLUS)**



**PLEASE BE CAREFUL DO NOT DAMAGE THE HOLE POSITION WHEN YOU USE POWER TOOLS !**  
**NE PAS UTILISEZ DES OUTILS ÉLECTRIQUES POUR ASSEMBLER CE PRODUIT !**

# STEP 1:

ÉTAPE

5



14PCS

10



14PCS

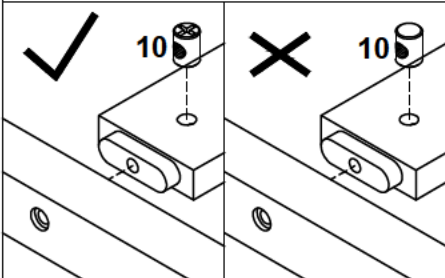
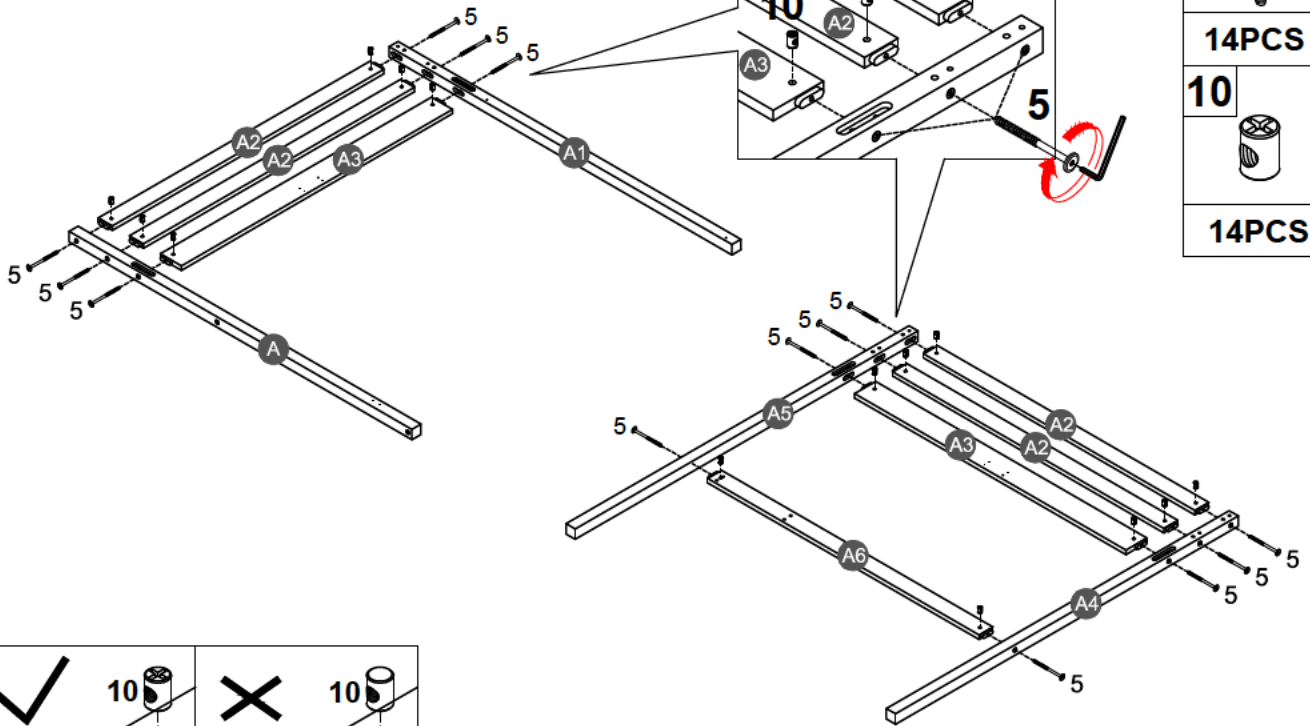

Note: Part 10 will face up with the "x" mark on it, otherwise it cannot be tightened

Remarque: La pièce 10 sera face vers le haut avec la marque "x", sinon elle ne peut pas être serrée.

# STEP 2:

ÉTAPE

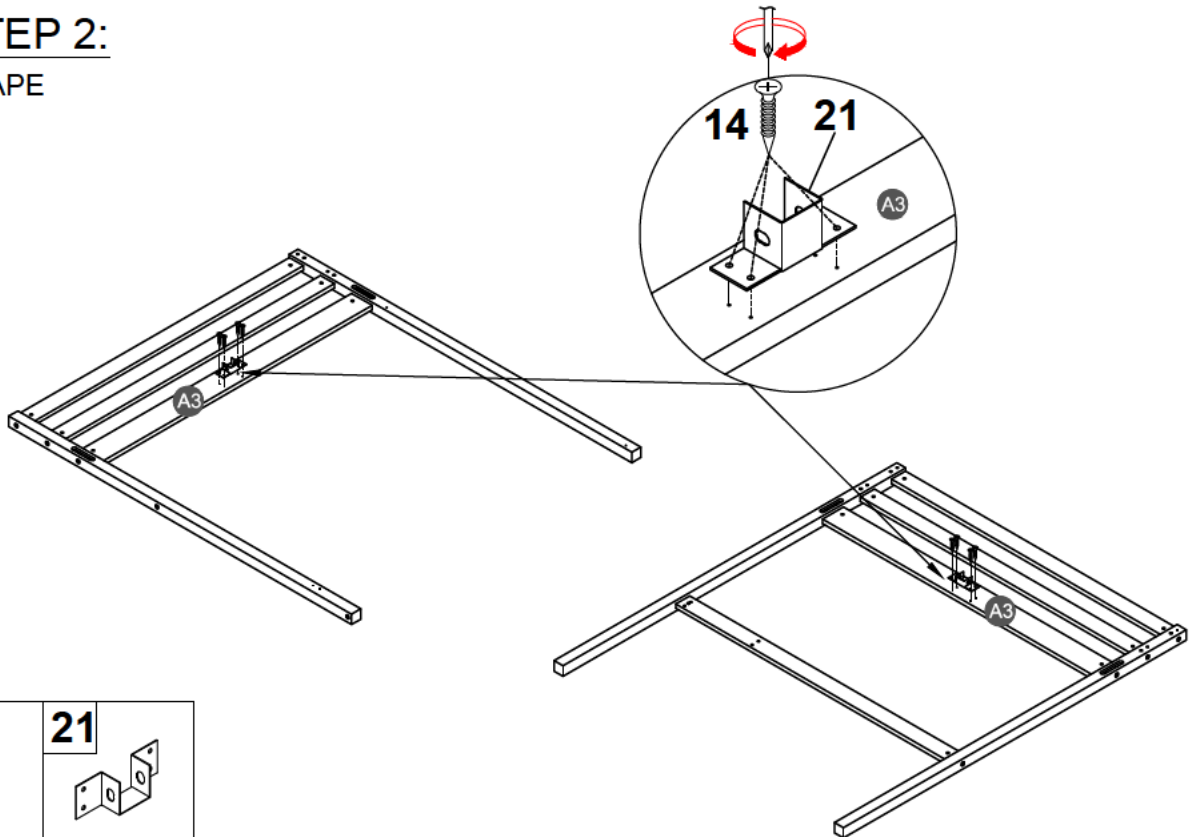

<p>14</p>	<p>21</p>
<p>8PCS</p>	<p>2PCS</p>

**STEP 3:**  
ÉTAPE

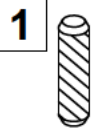
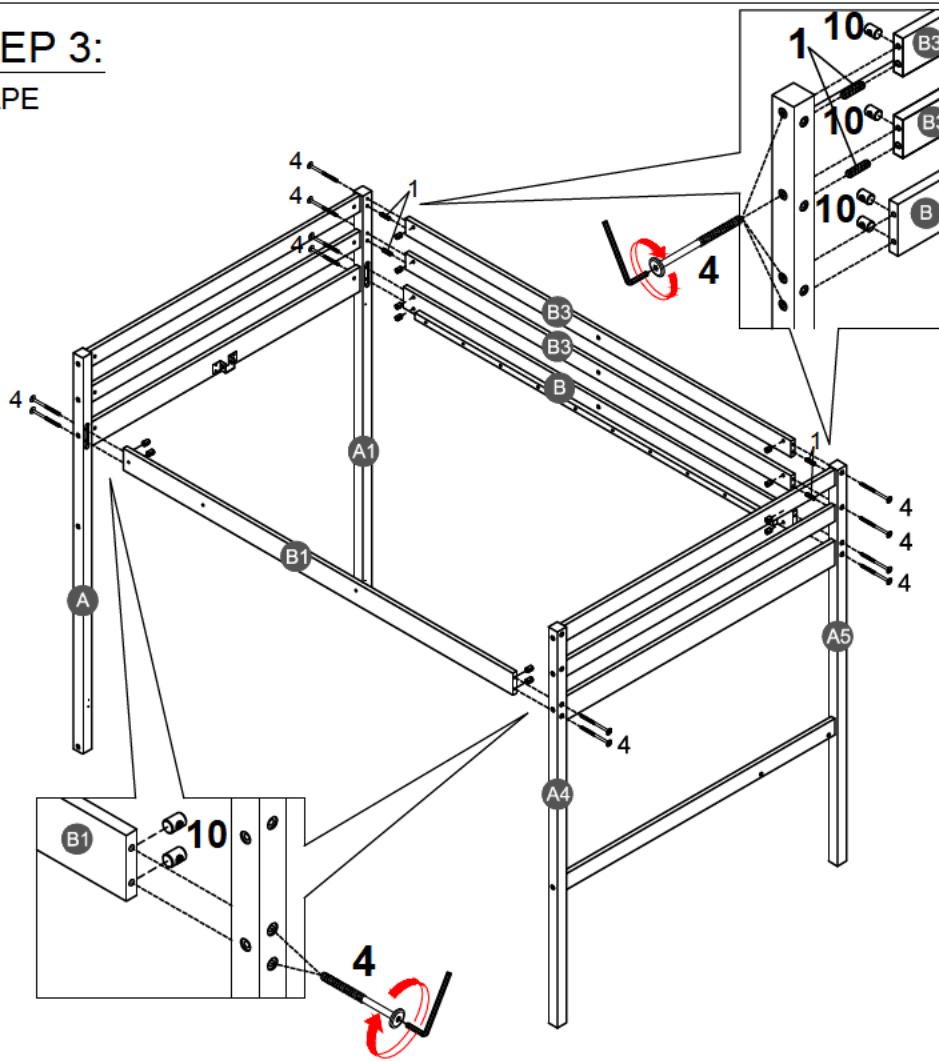

4PCS



12PCS





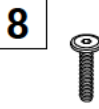
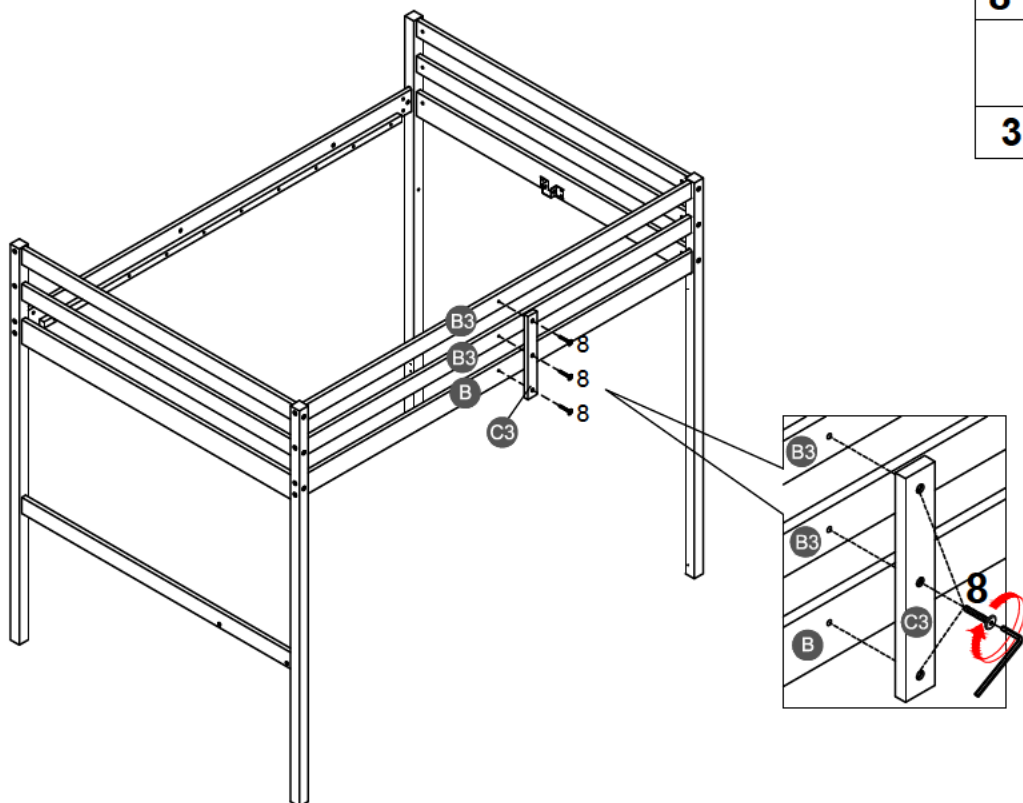

12PCS

**STEP 4:**  
ÉTAPE





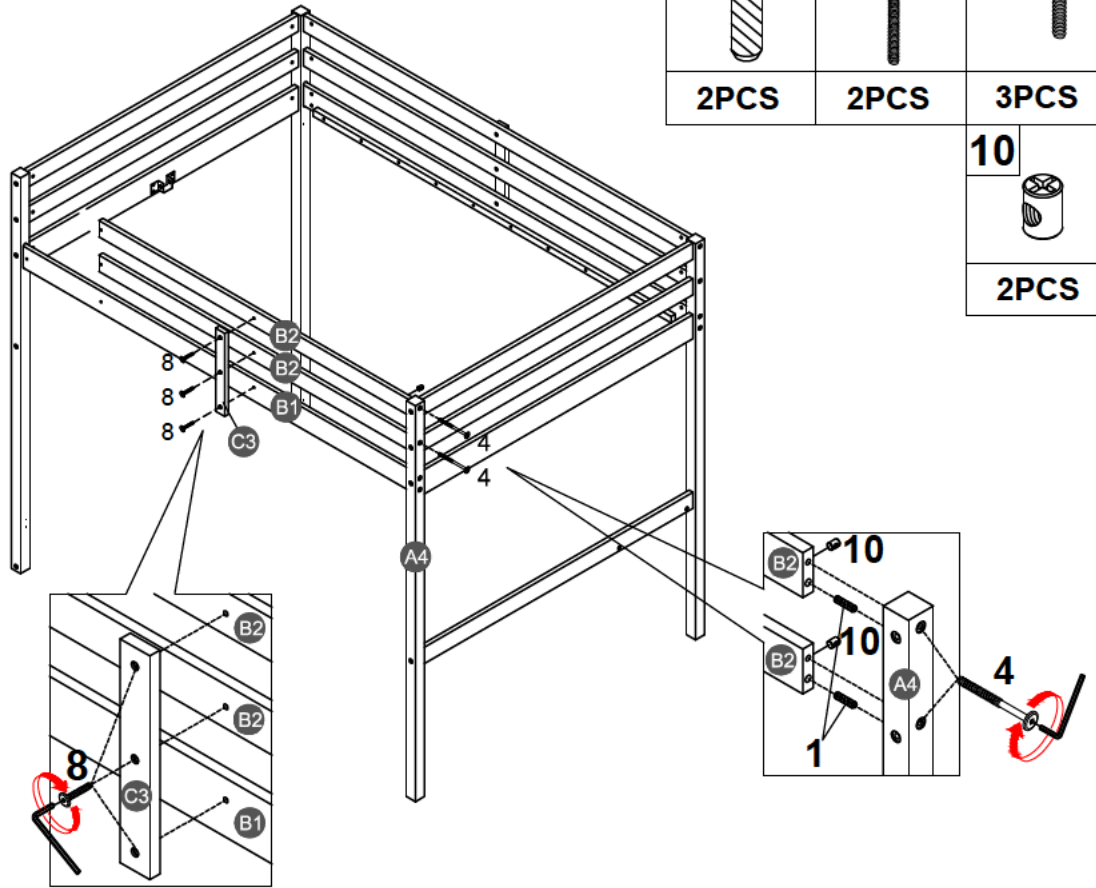

3PCS

**STEP 5:**  
ÉTAPE

<b>1</b> 	<b>4</b> 	<b>8</b> 
<b>2PCS</b>	<b>2PCS</b>	<b>3PCS</b>
		<b>10</b> 
		<b>2PCS</b>



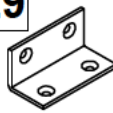

**STEP 6:**  
ÉTAPE

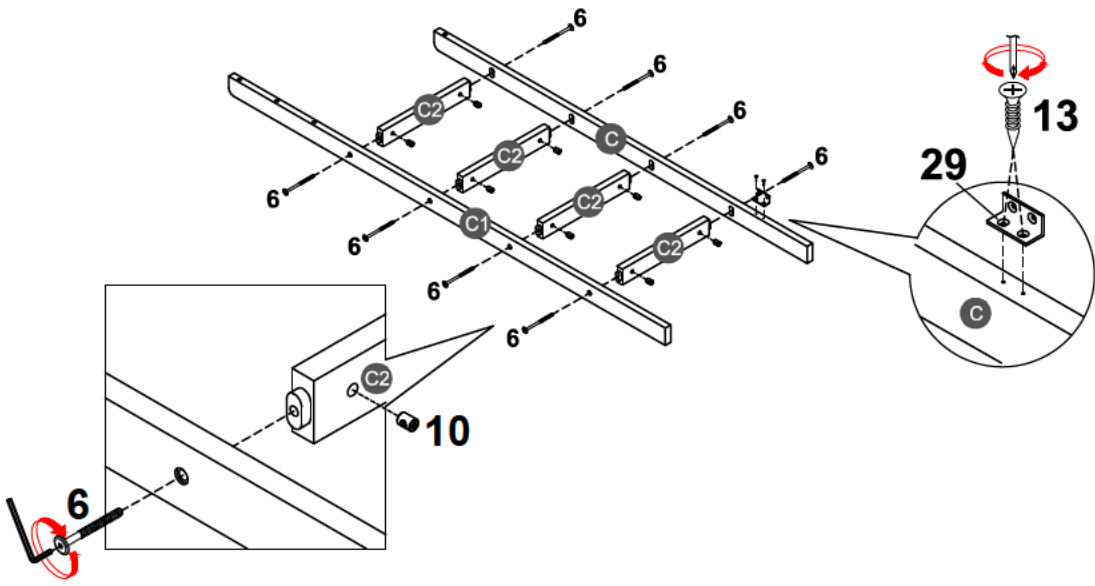
<b>6</b> 	<b>10</b> 	<b>29</b> 	<b>13</b> 
<b>8PCS</b>	<b>8PCS</b>	<b>1PC</b>	<b>2PCS</b>



**STEP 7:**  
ÉTAPE

<b>7</b>		<b>13</b>	
<b>4PCS</b>		<b>2PCS</b>	

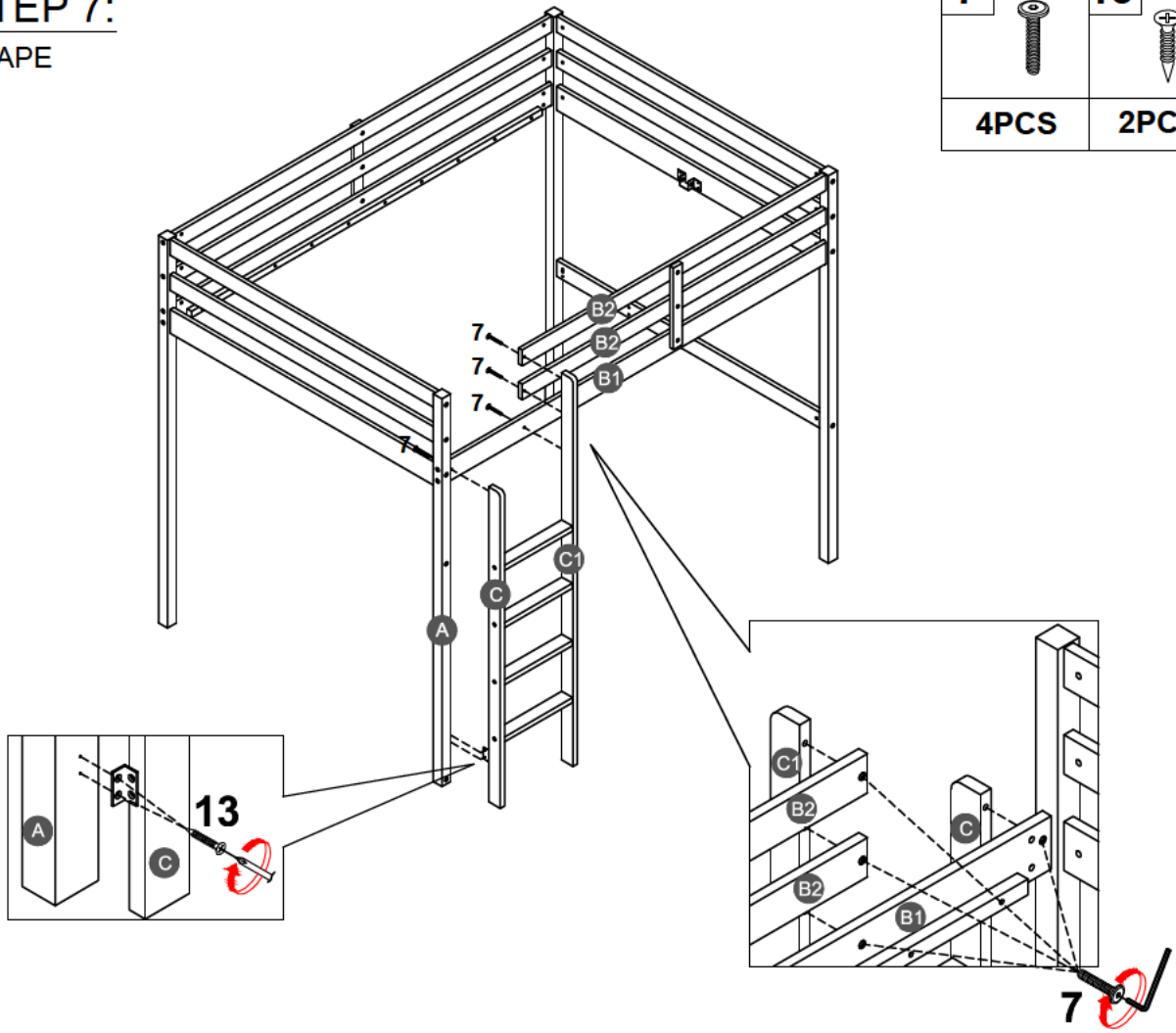

**STEP 8:**  
ÉTAPE

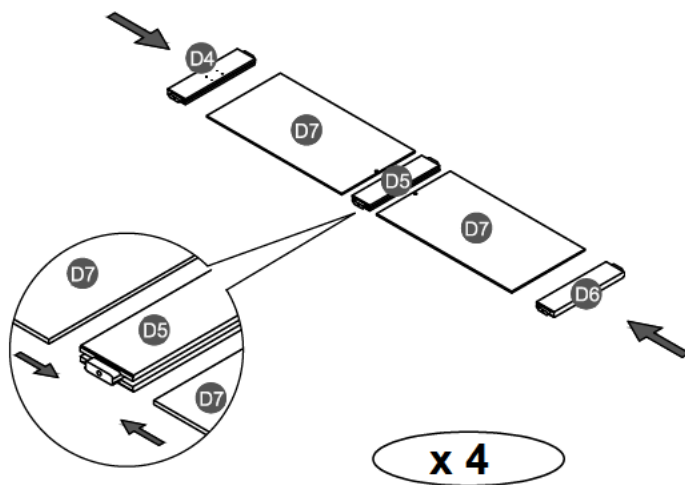

### STEP 09:

ÉTAPE

16



12PCS

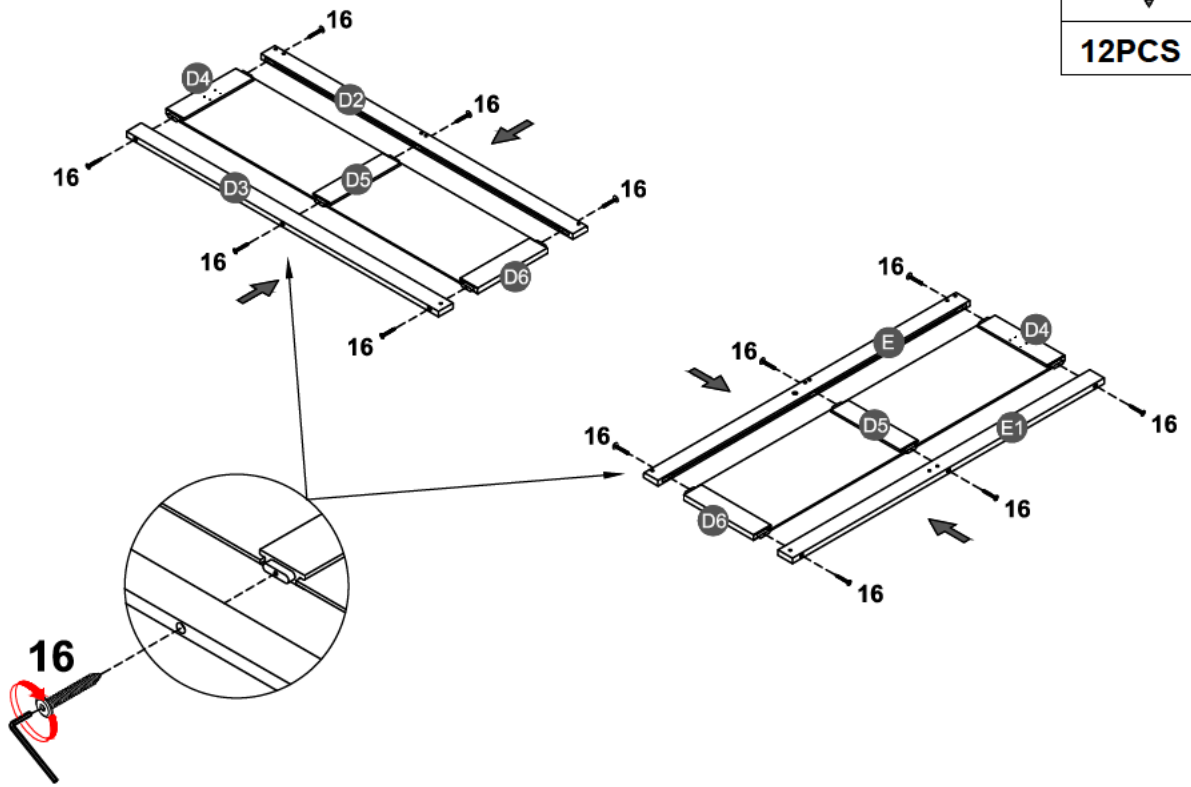

### STEP 10:

ÉTAPE

14



8PCS

22



2PCS

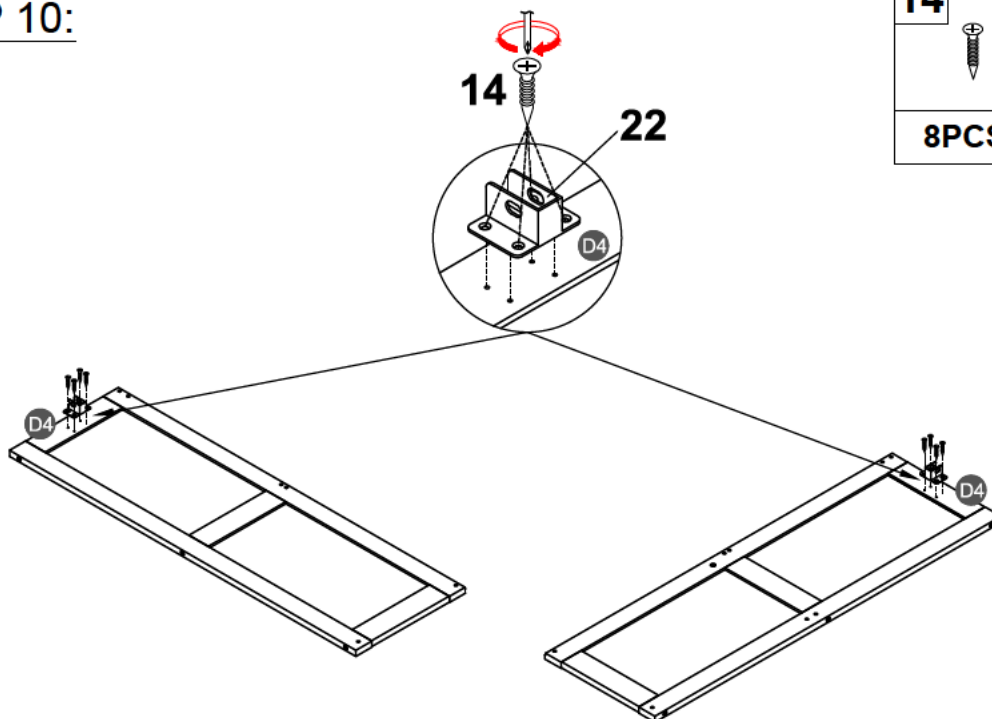

**STEP 11:**  
ÉTAPE

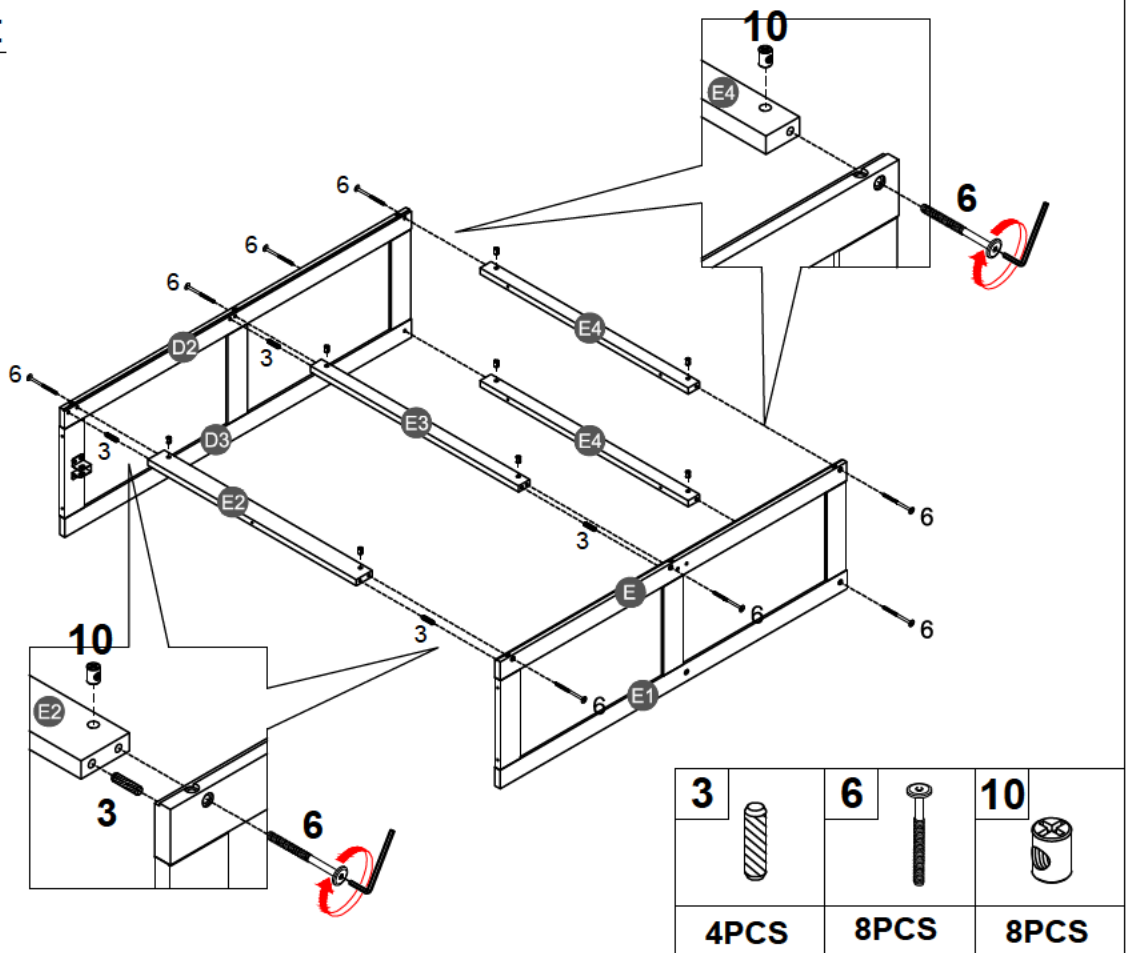

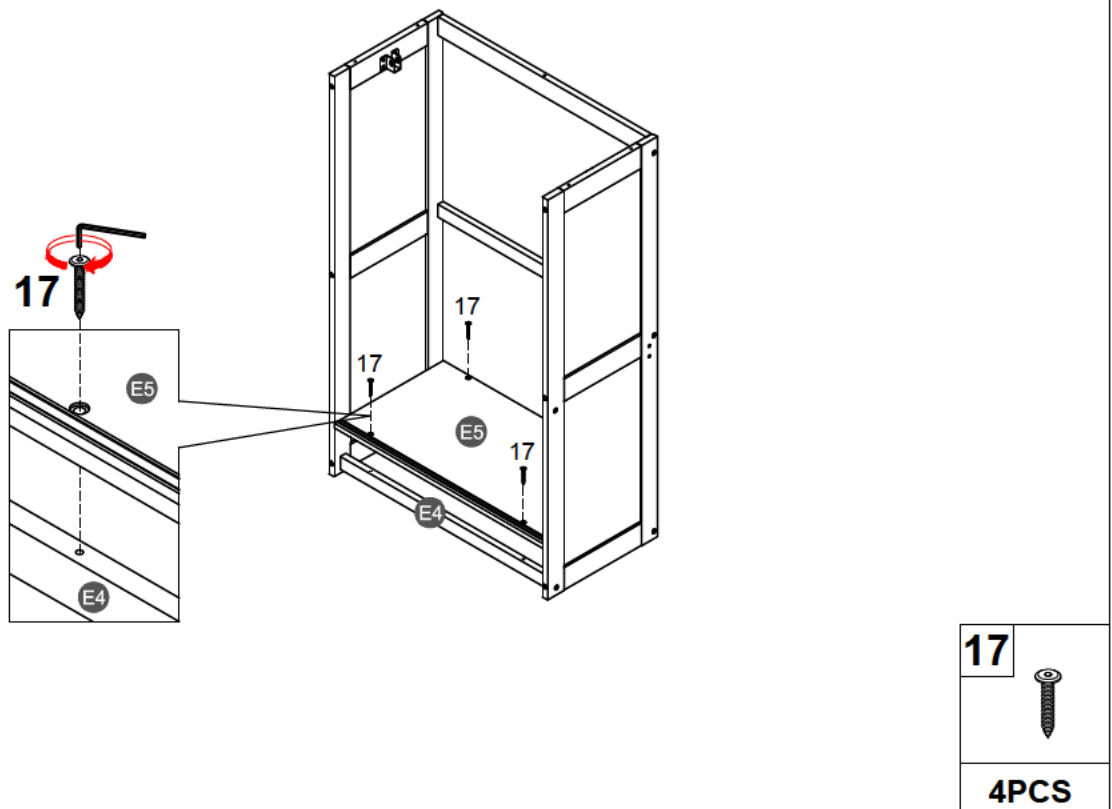

**STEP 12:**  
ÉTAPE

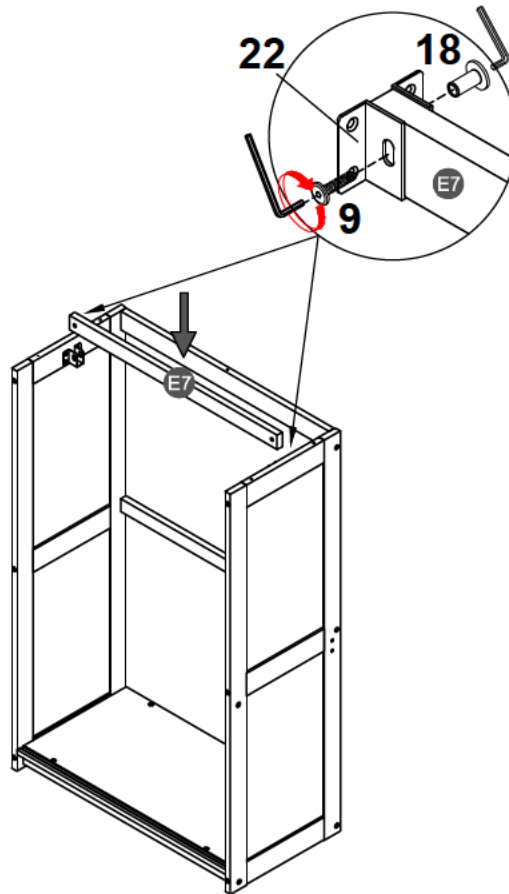

### STEP 13:

ÉTAPE



<b>9</b>	<b>18</b>
	
<b>2PCS</b>	<b>2PCS</b>

### STEP 14:

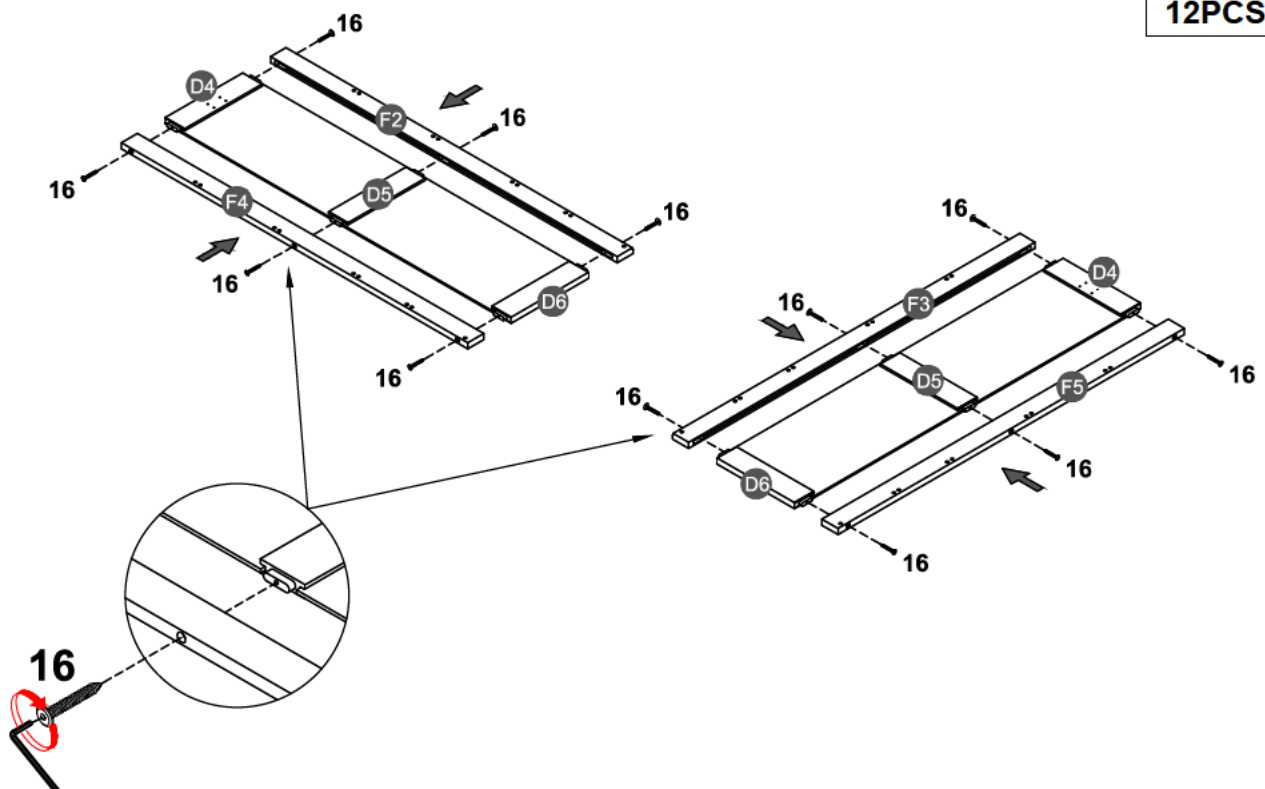

ÉTAPE

<b>16</b>

<b>12PCS</b>



# STEP 15:

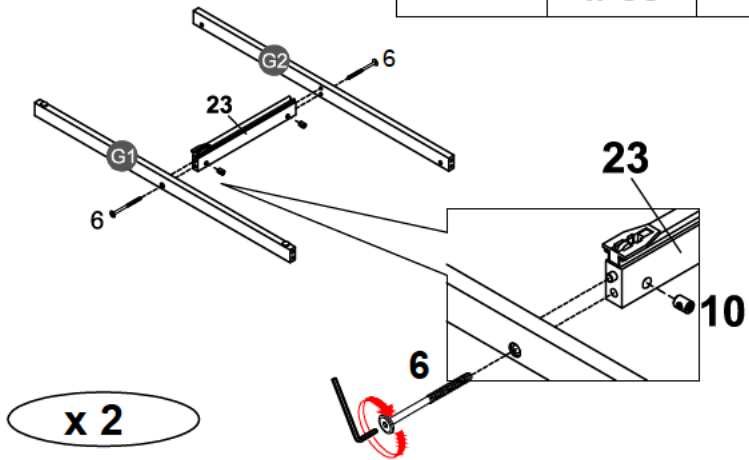

ÉTAPE

<b>6</b>		<b>10</b>		<b>23</b>	
<b>4PCS</b>		<b>4PCS</b>		<b>2PCS</b>	



# STEP 16:

ÉTAPE

<b>3</b>		<b>6</b>		<b>10</b>	
<b>16PCS</b>		<b>18PCS</b>		<b>18PCS</b>	

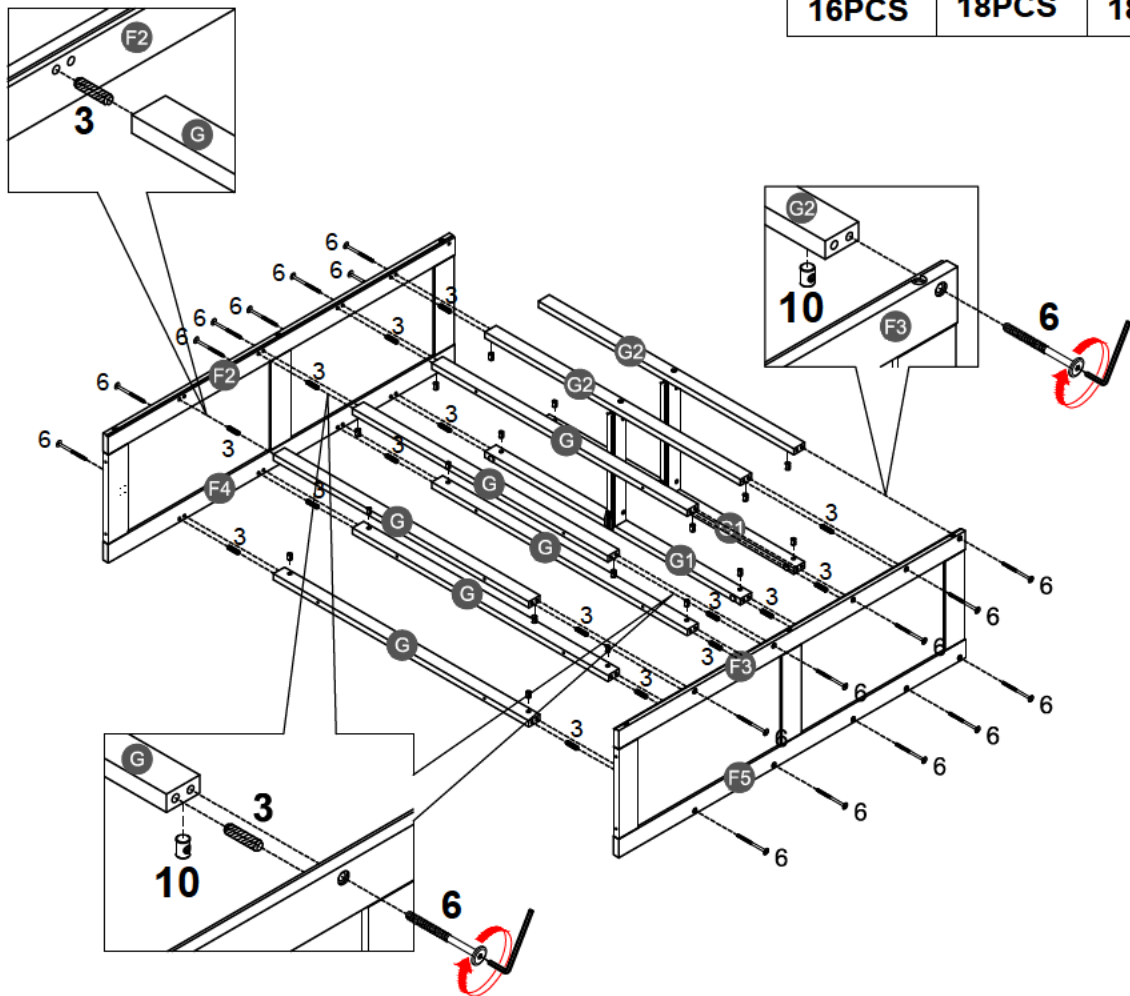

## STEP 17:

ÉTAPE

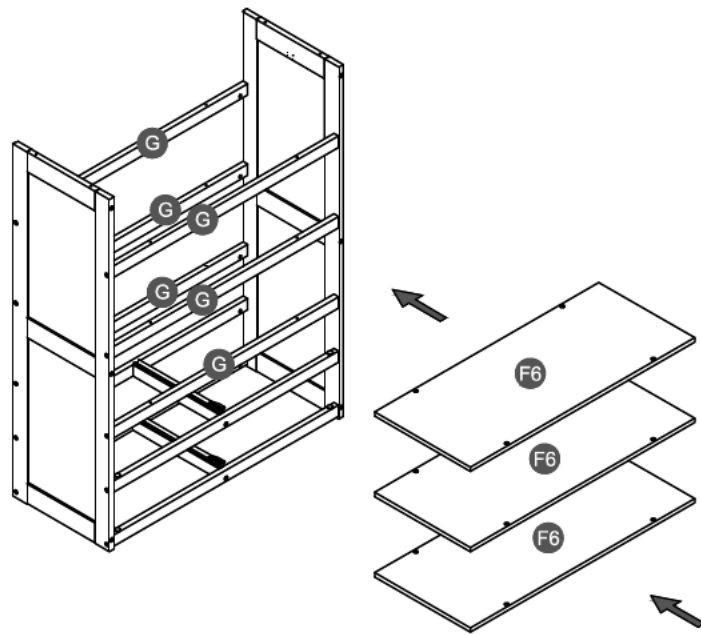

## STEP 18:

ÉTAPE

17



12PCS

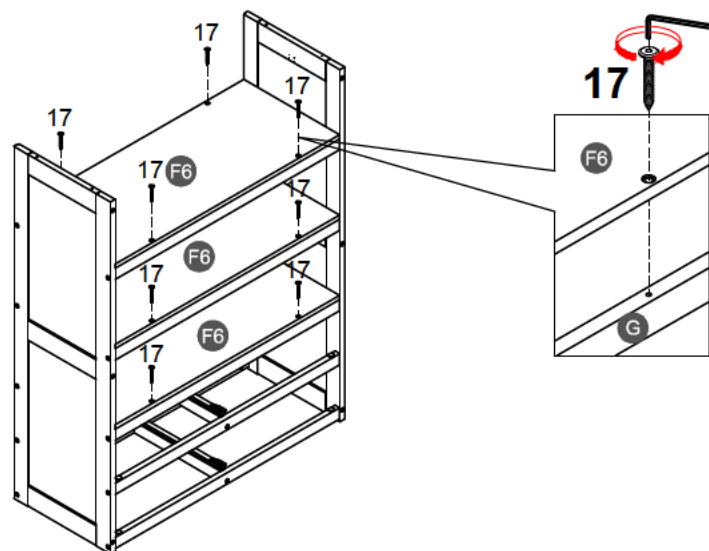

# STEP 19:

ÉTAPE

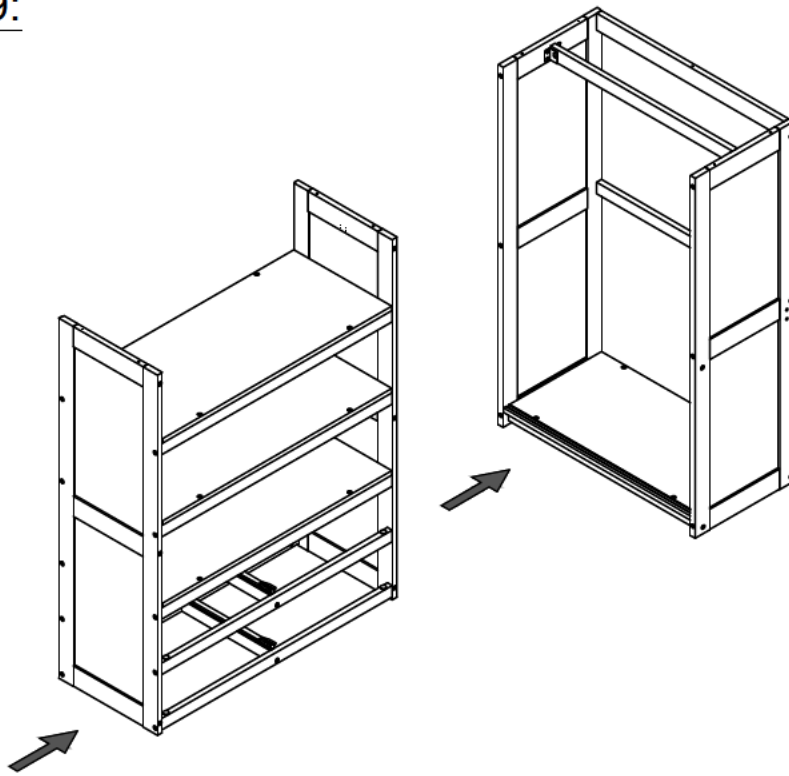

# STEP 20:

ÉTAPE

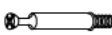
<b>16</b>		<b>25</b>	
<b>2PCS</b>		<b>1PC</b>	

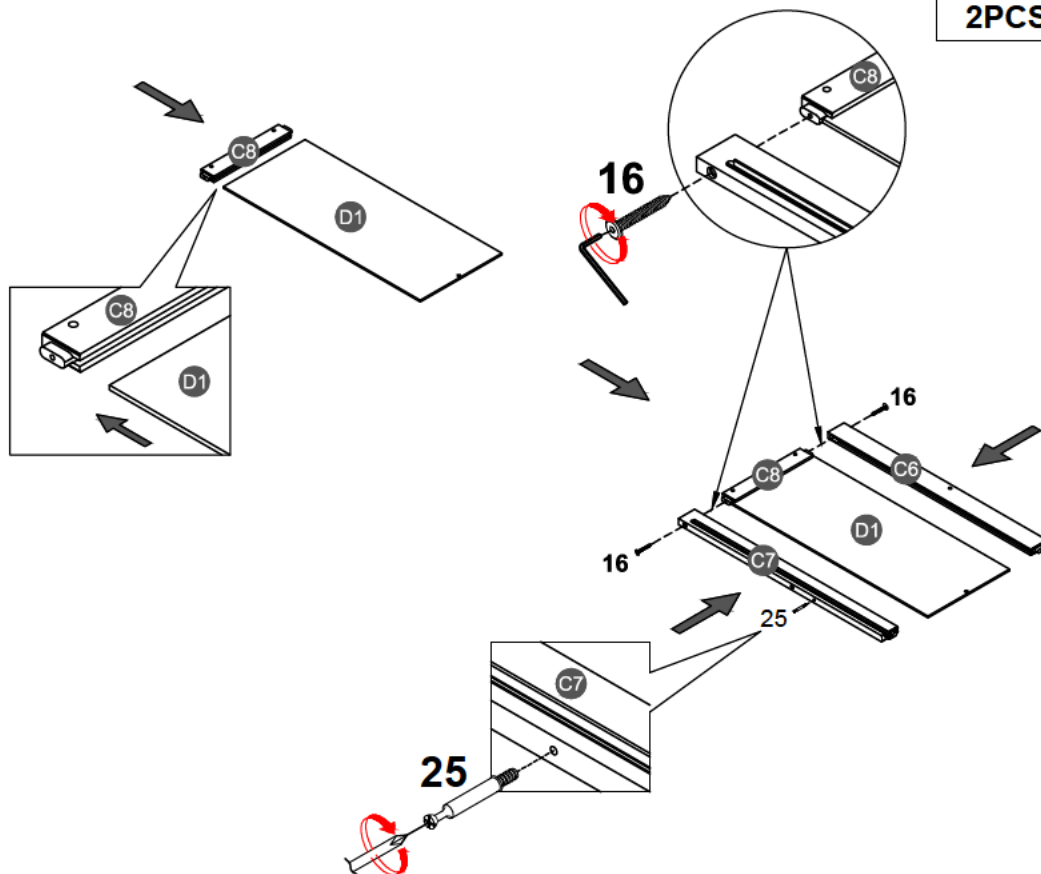

## STEP 21:

ÉTAPE

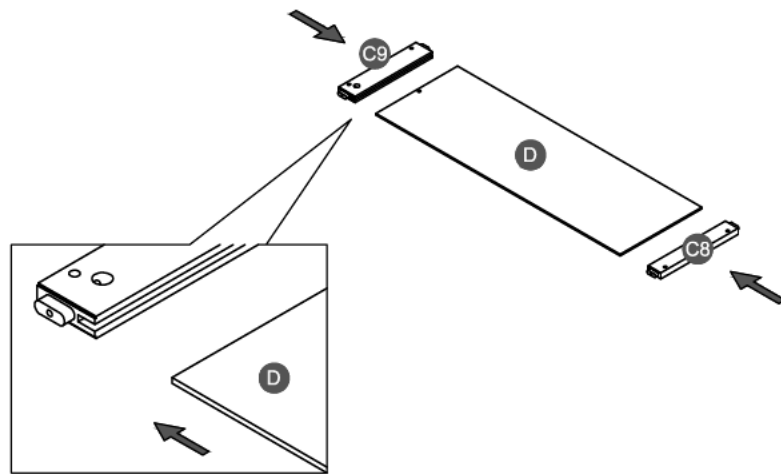

## STEP 22:

ÉTAPE

16



2PCS

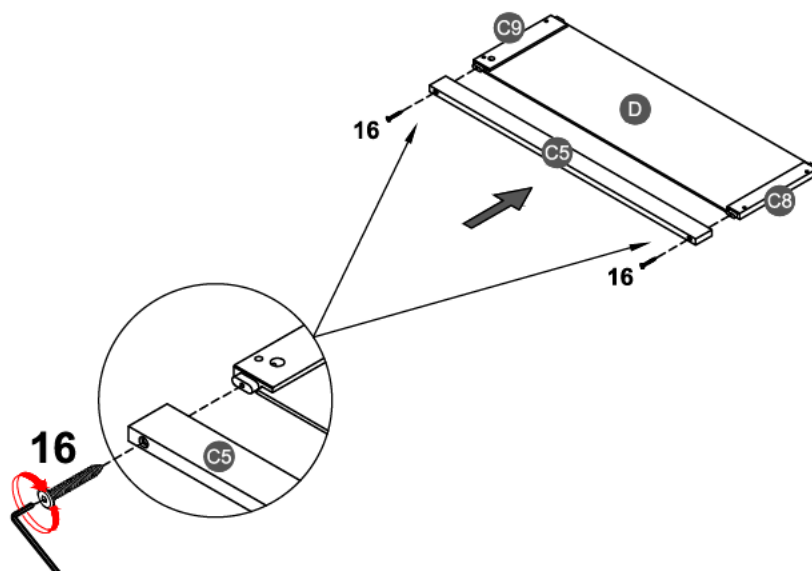

### STEP 23:

ÉTAPE

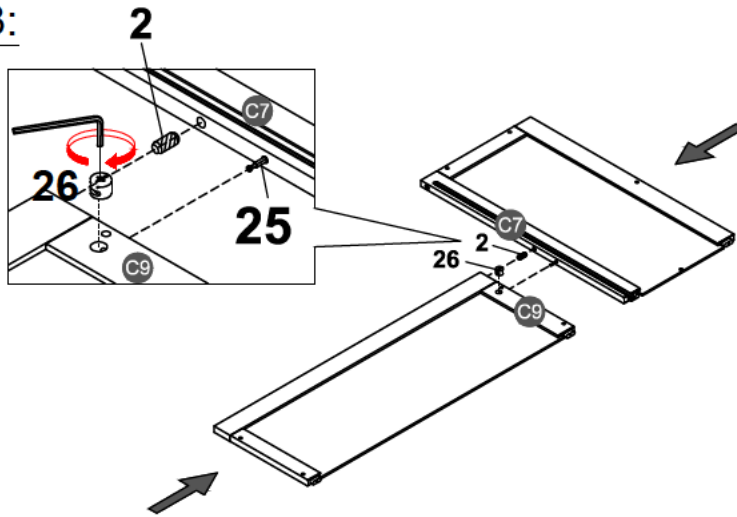

<b>2</b>	<b>26</b>
<b>1PC</b>	<b>1PC</b>

Note: Place hardware #26 with the "X" face outward, and make sure that the arrowhead is upward. Then, place hardware #26 into the hole of hardware #25 and tighten it clockwise with a hand screwdriver. (Please do NOT use an electric screwdriver.)

Remarque : placez la quincaillerie #26 avec la face « X » vers l'extérieur, et assurez-vous que la pointe de la flèche est vers le haut. Ensuite, placez le matériel #26 dans le trou de la quincaillerie #25 et serrez-le dans le sens des aiguilles d'une montre avec un tournevis à main. (Veuillez ne PAS utiliser de tournevis électrique.)

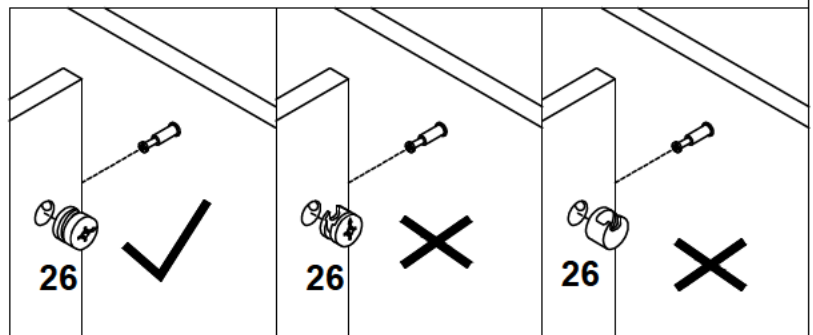

### STEP 24:

ÉTAPE

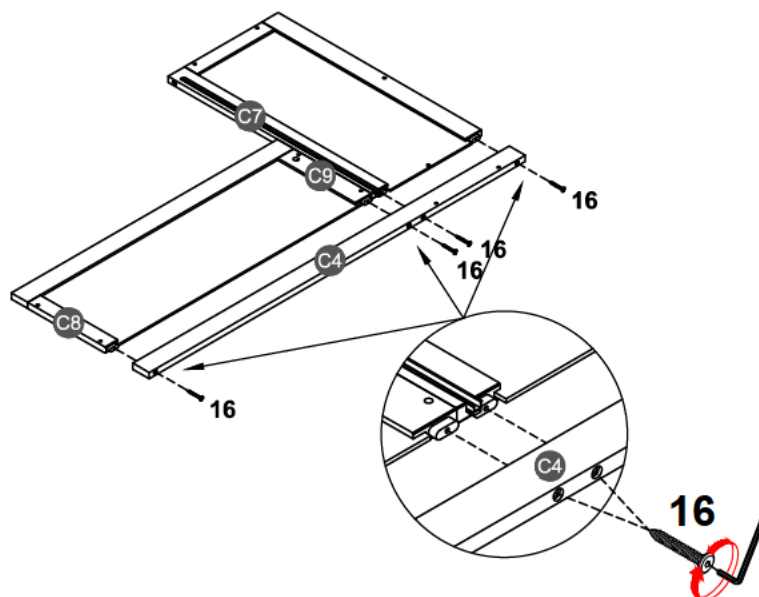

<b>16</b>	
<b>4PCS</b>	

# STEP 25:

ÉTAPE

17



9PCS

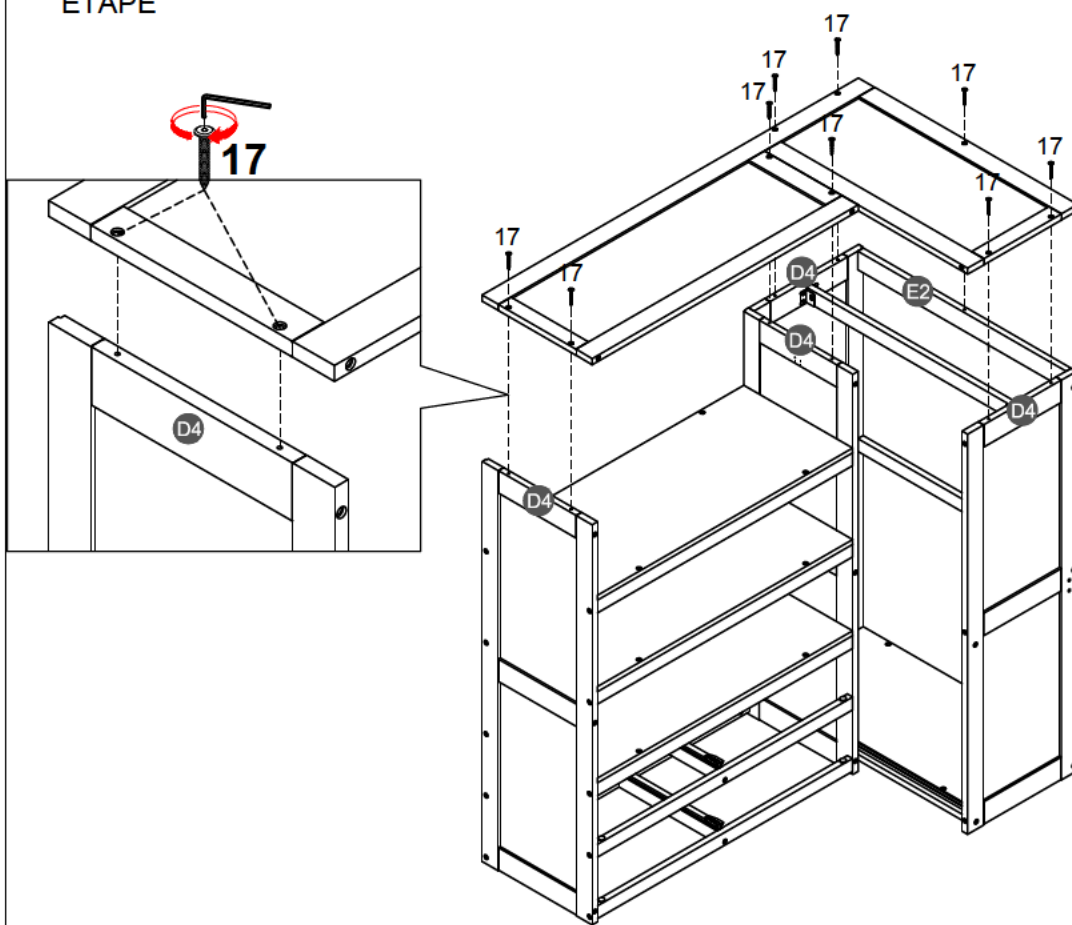

# STEP 26:

ÉTAPE

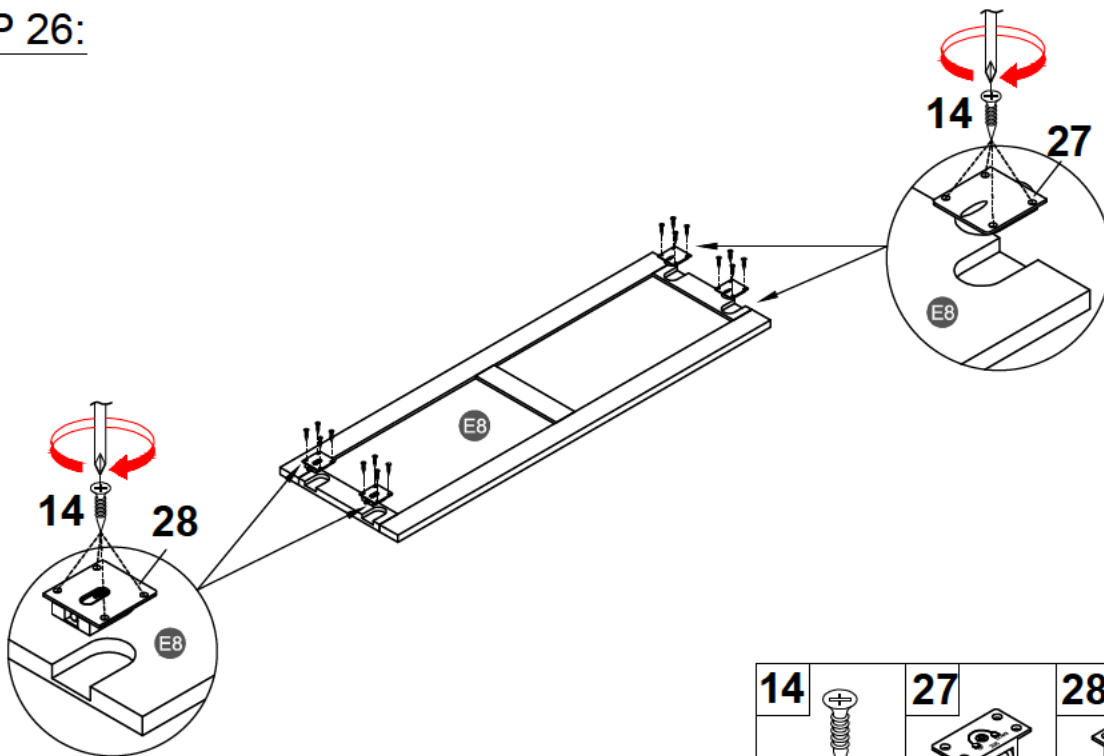

14	27	28
16PCS	2PCS	2PCS

# STEP 27:

ÉTAPE

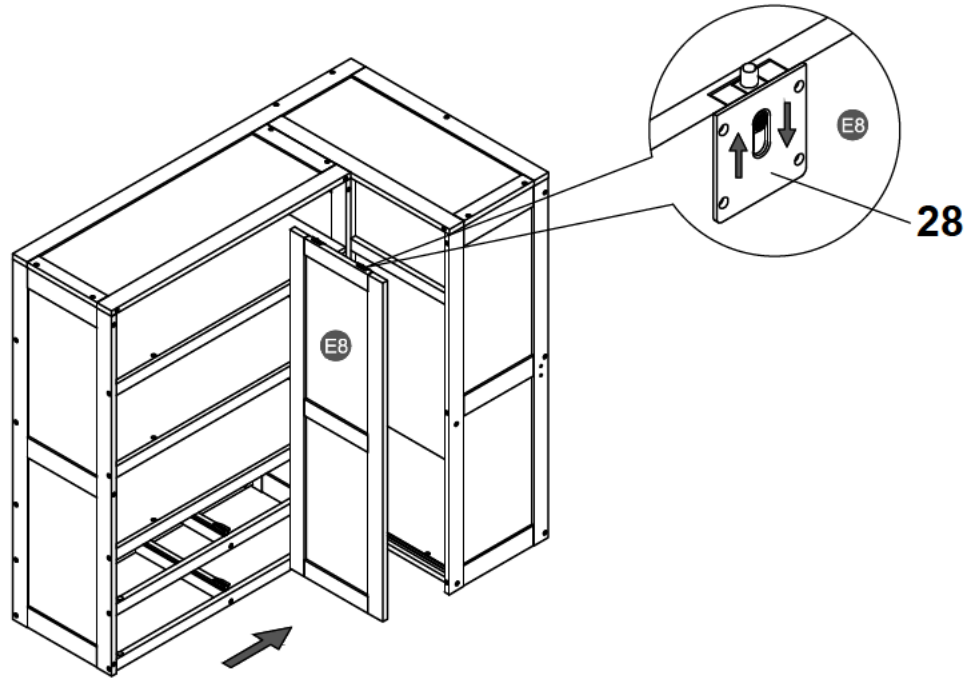

# STEP 28:

ÉTAPE

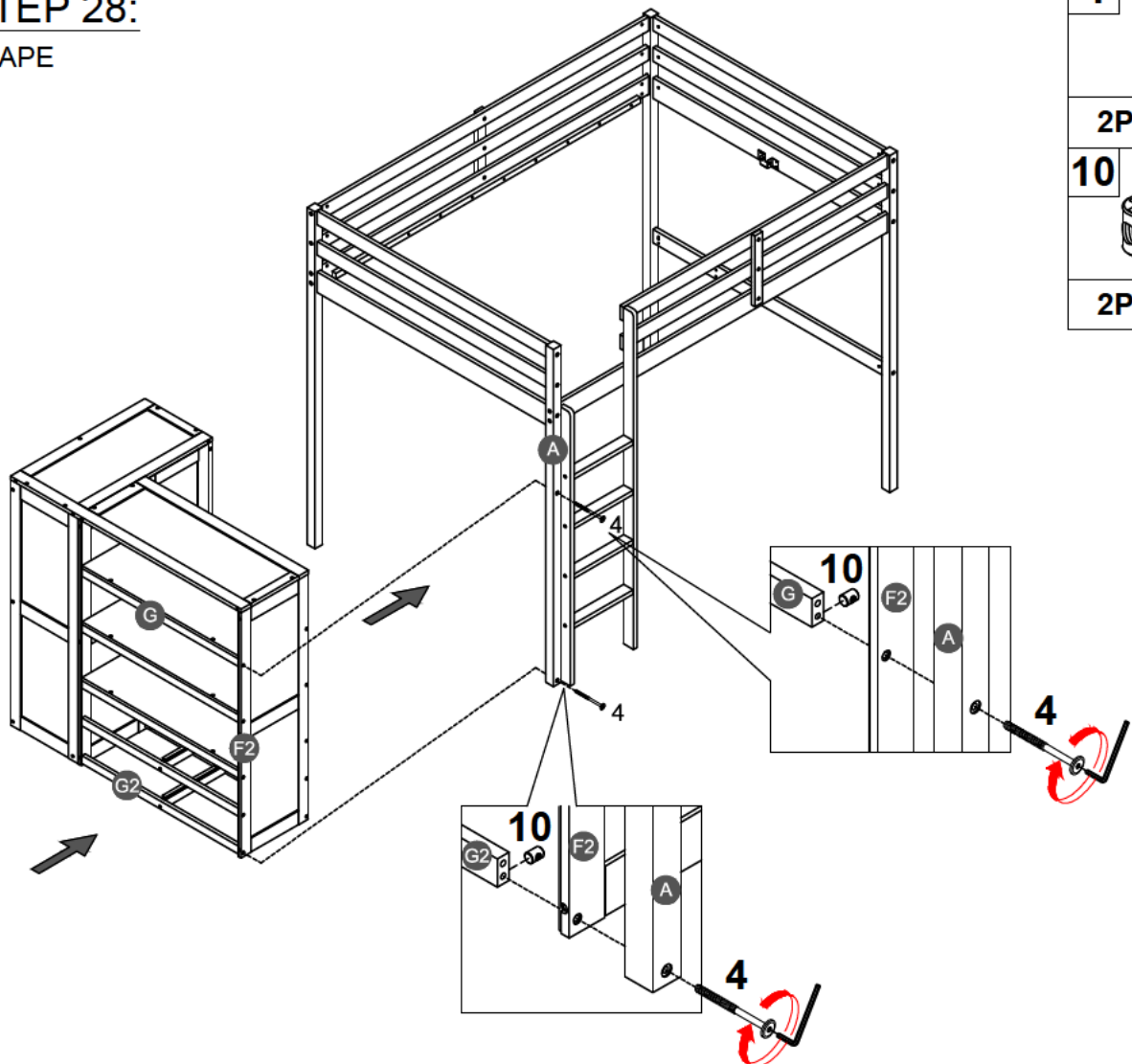

# STEP 29:

ÉTAPE

25

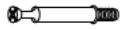

4PCS

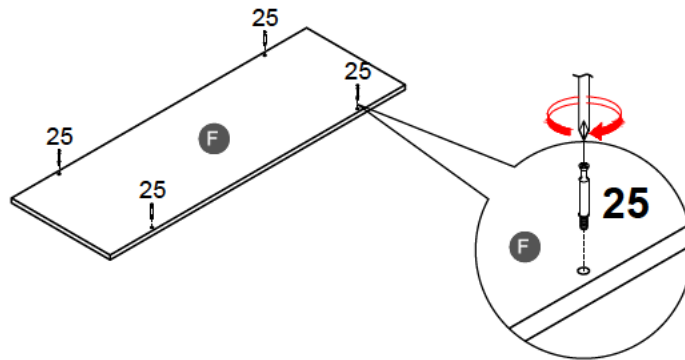

# STEP 30:

ÉTAPE

6



4PCS

10



4PCS

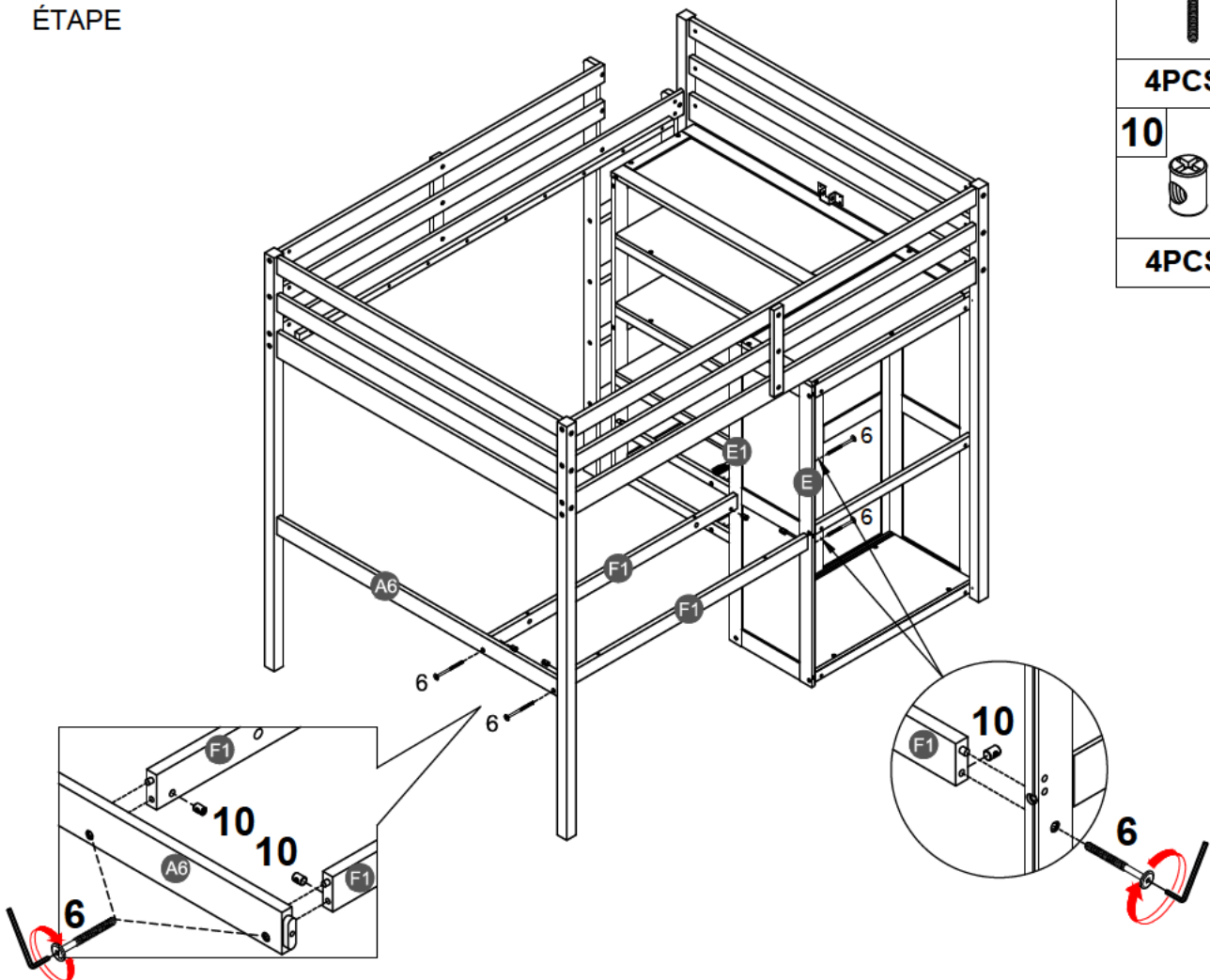

# STEP 31:

ÉTAPE

26



4PCS

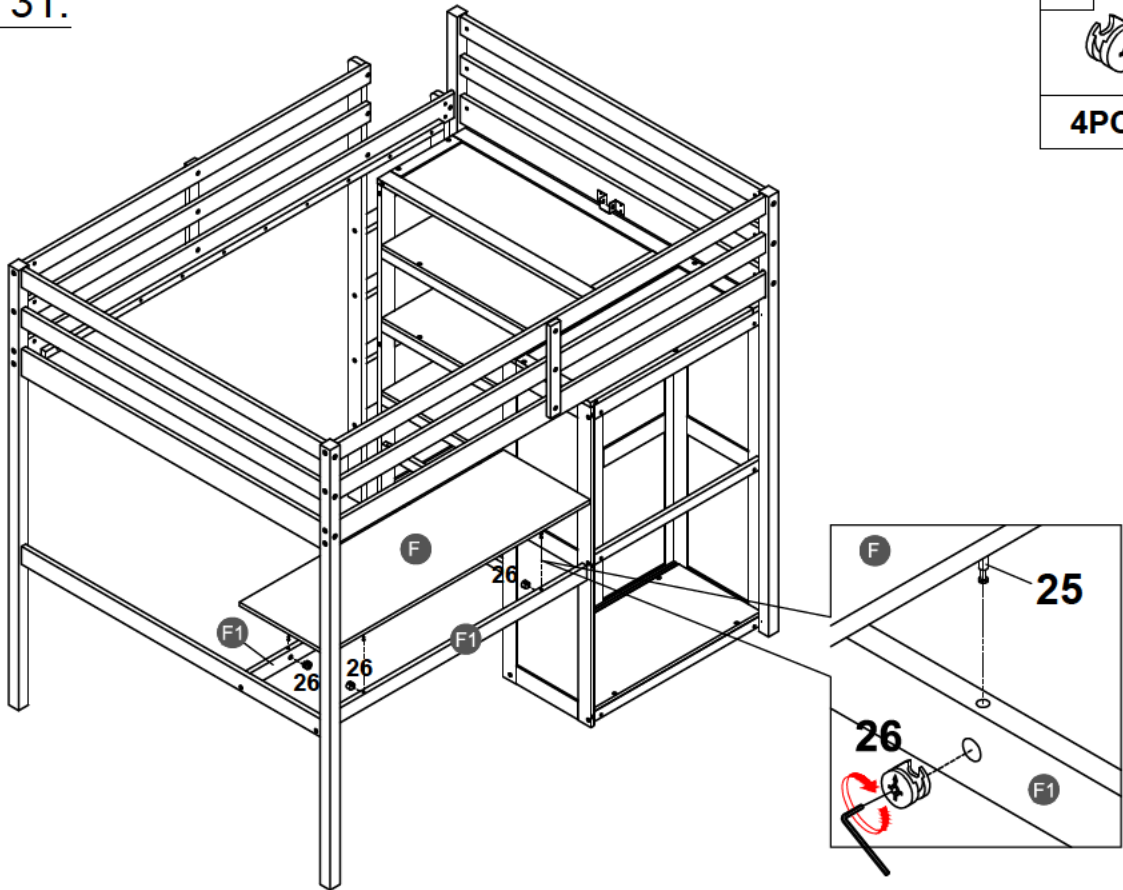

# STEP 32:

ÉTAPE

15



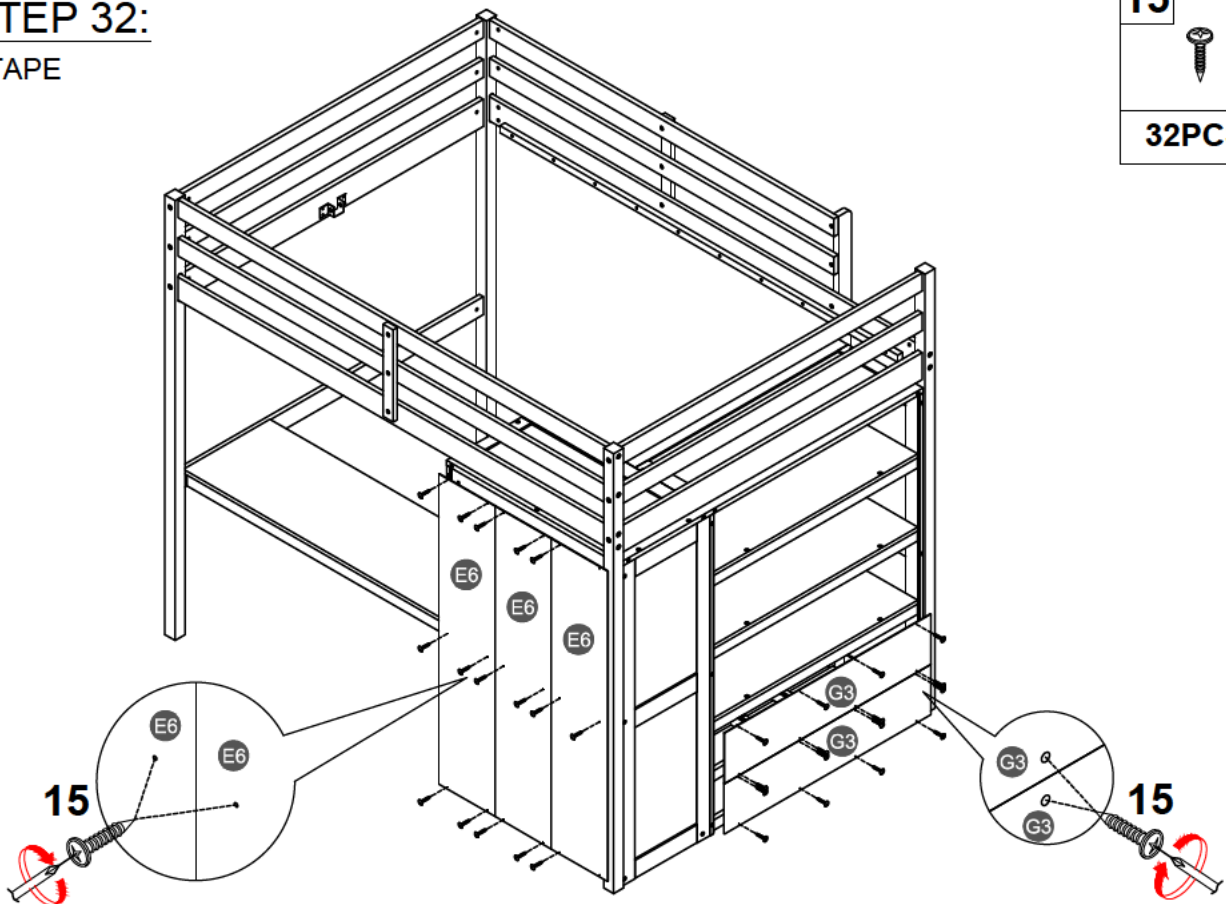

32PCS



# STEP 33:

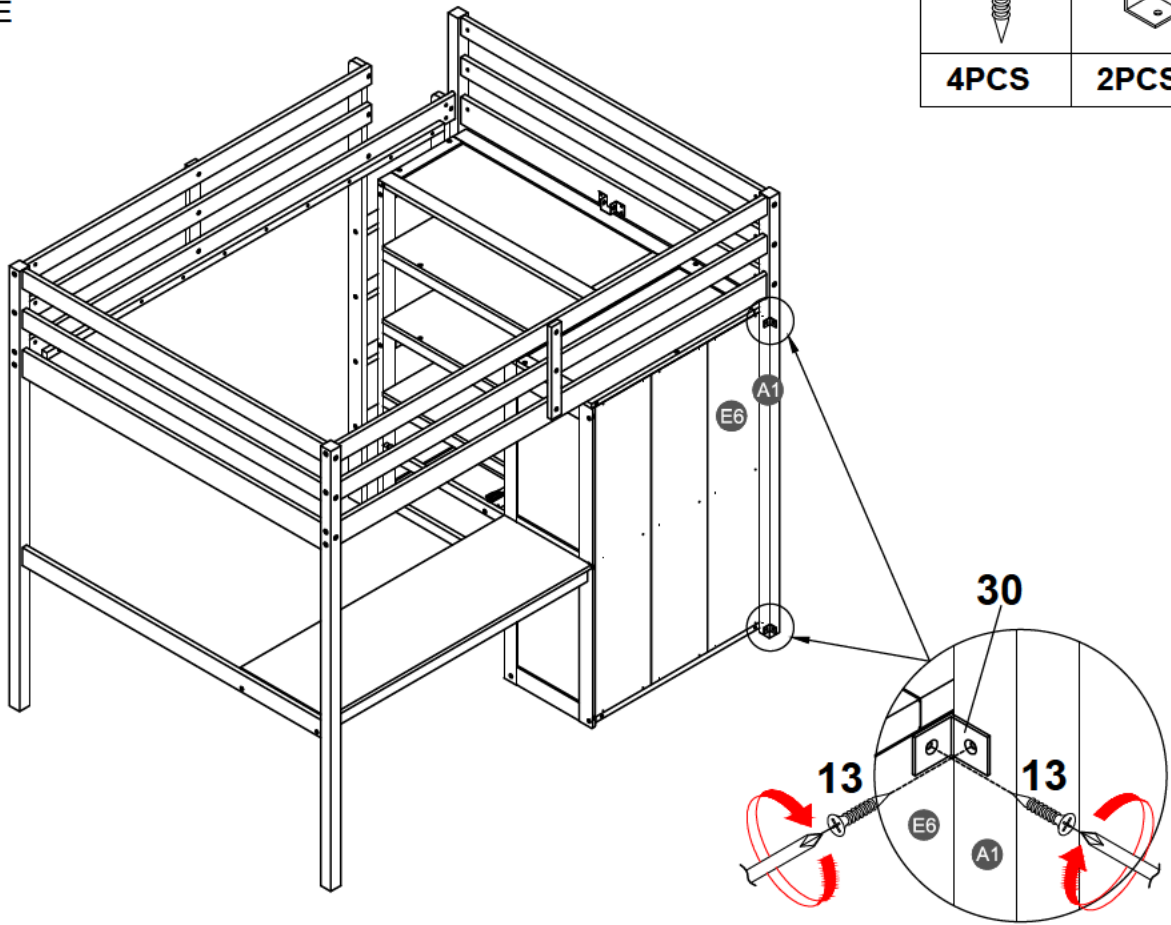

ÉTAPE

<b>13</b>		<b>30</b>	
<b>4PCS</b>		<b>2PCS</b>	



# STEP 34:

ÉTAPE

<b>3</b>		<b>6</b>	
<b>8PCS</b>		<b>4PCS</b>	
		<b>10</b>	
		<b>4PCS</b>	

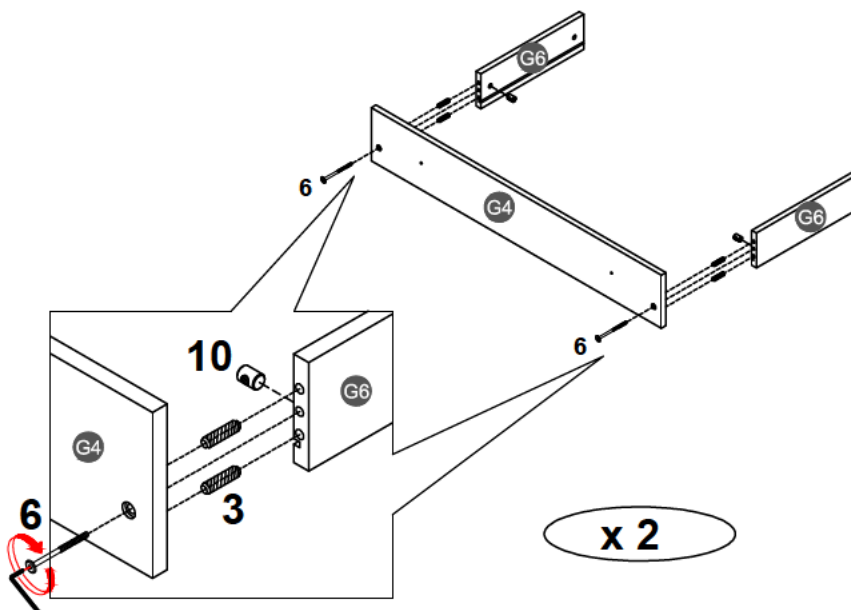

**STEP 35:**  
ÉTAPE

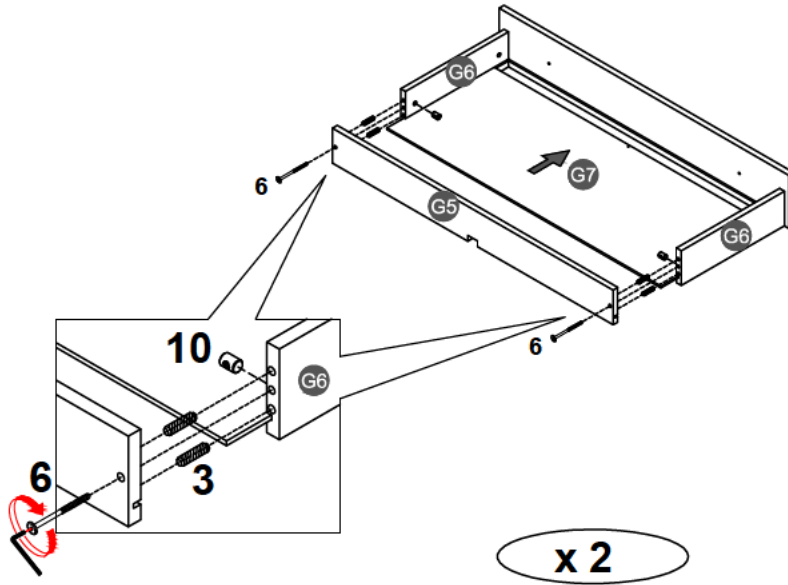

<b>3</b>		<b>6</b>	
<b>8PCS</b>		<b>4PCS</b>	
		<b>10</b>	
		<b>4PCS</b>	

**STEP 36:**  
ÉTAPE

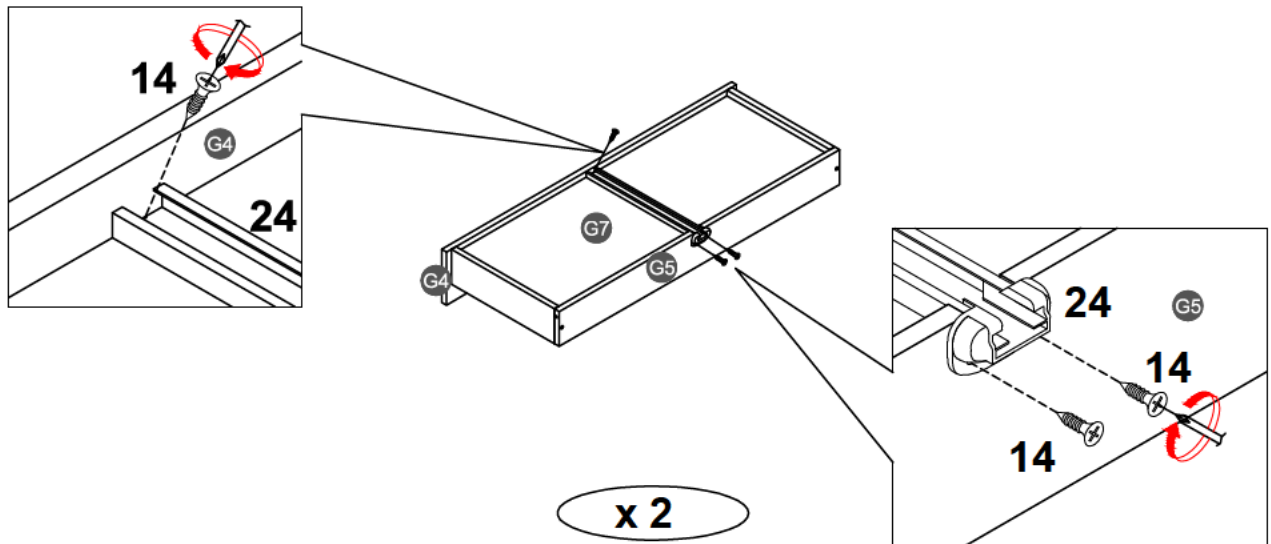

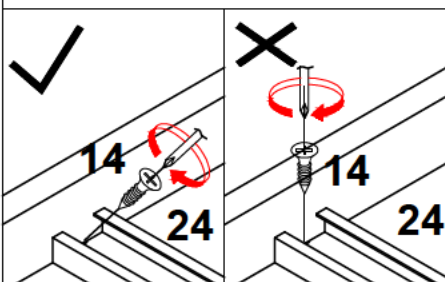

<b>14</b>		<b>24</b>	
<b>6PCS</b>		<b>2PCS</b>	



## STEP 37:

ÉTAPE

19	20
	
4PCS	4PCS

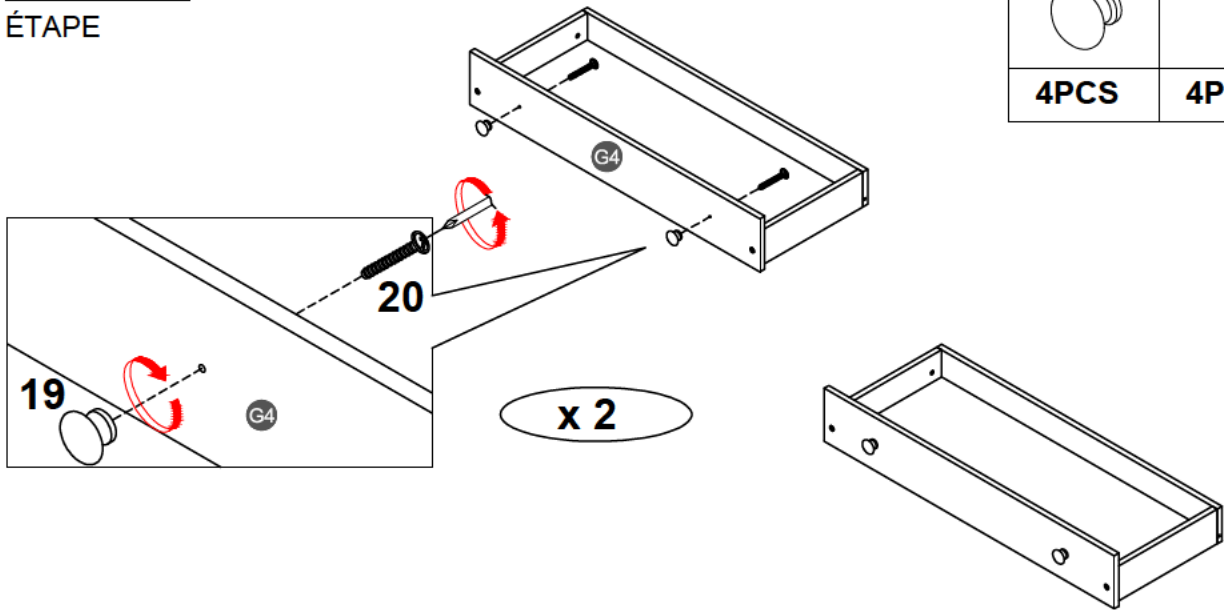

## STEP 38:

ÉTAPE

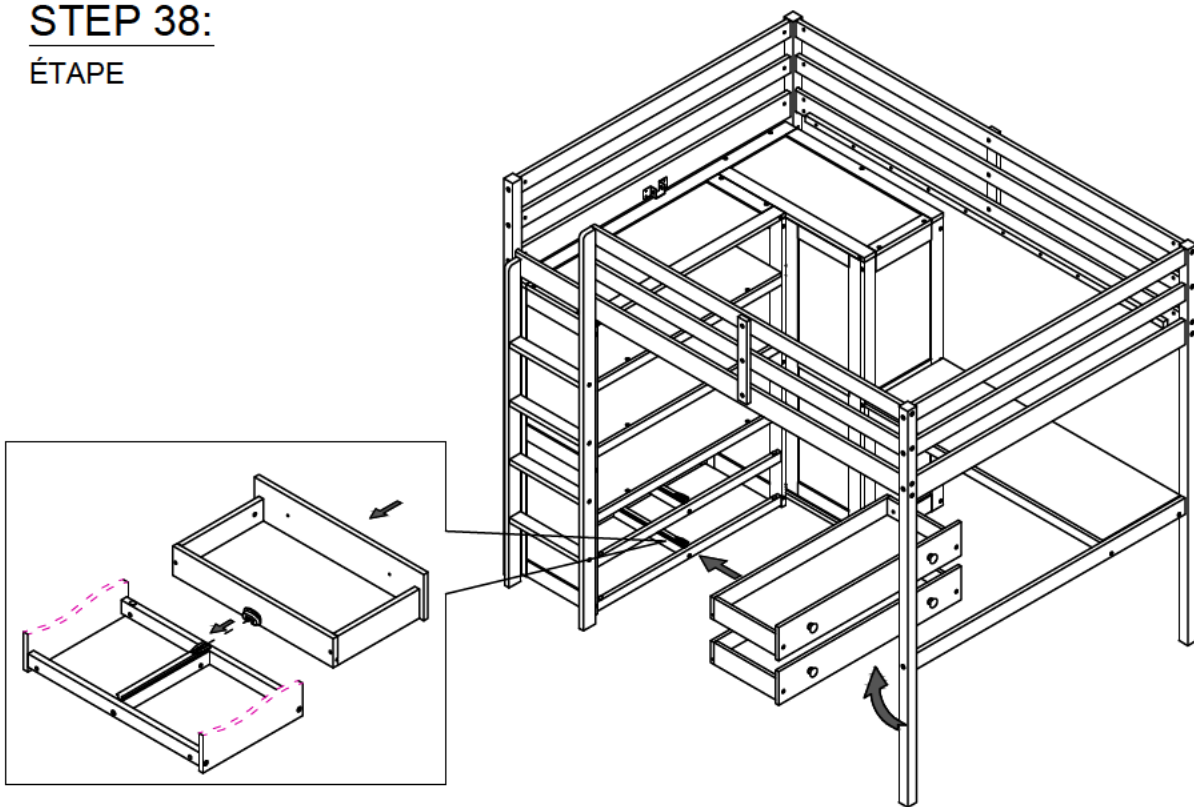

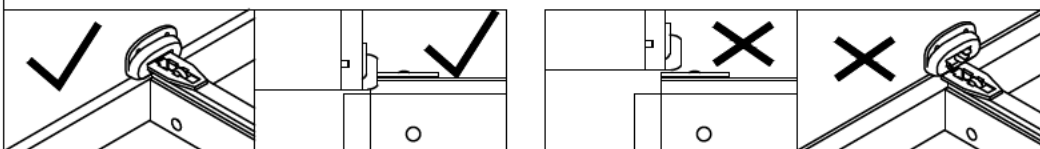

Align the slide rail at the bottom of the drawer and ensure it is secure, then push the drawer in firmly to make the slide rails smoothly on the track.

Alignez le rail coulissant au bas du tiroir et assurez-vous qu'il est sécurisé, puis poussez fermement le tiroir pour que les rails coulissants soient en douceur sur le rail.



# STEP 39:

ÉTAPE

7		18	
2PCS		2PCS	

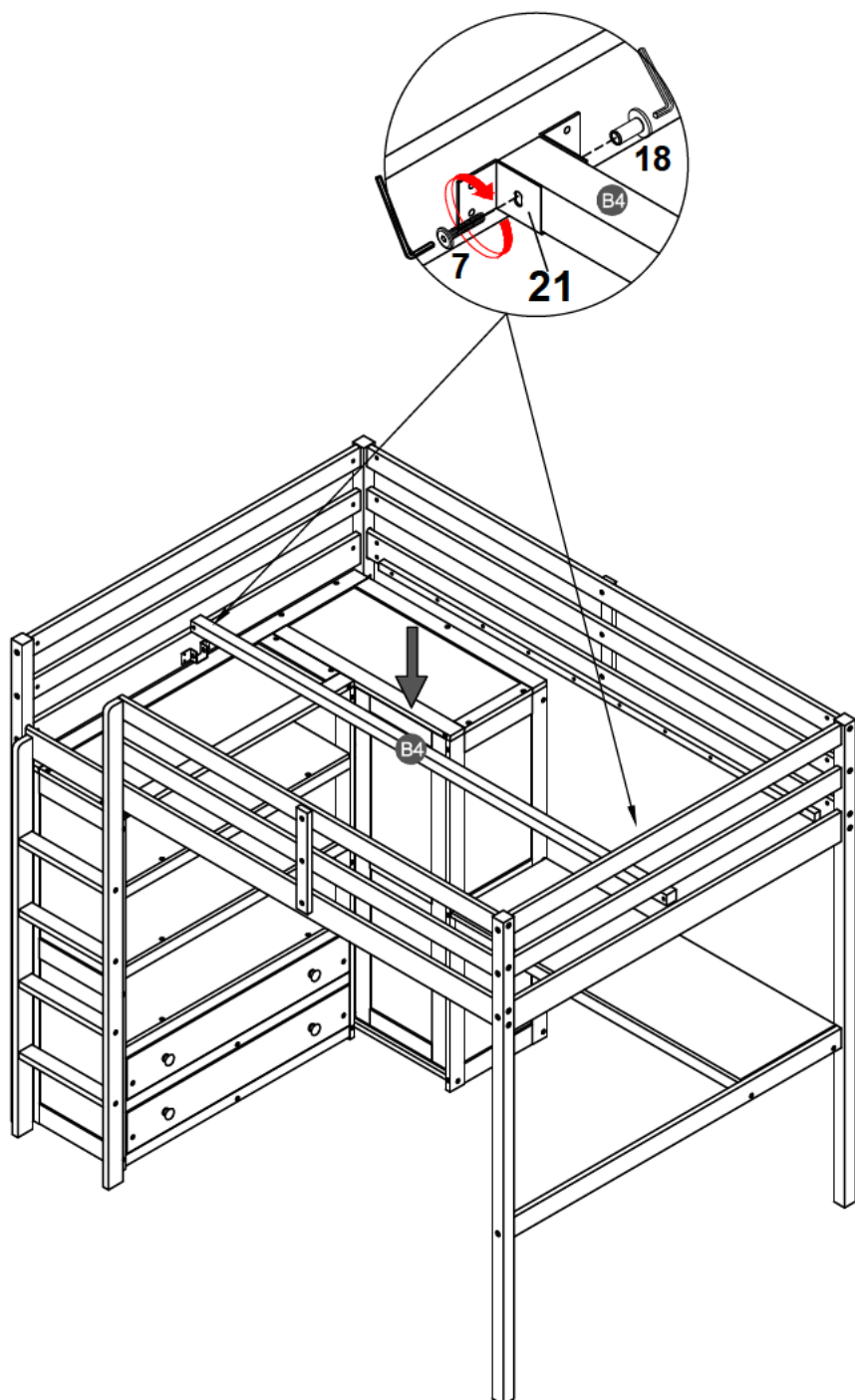

## STEP 40:

ÉTAPE

11



32PCS

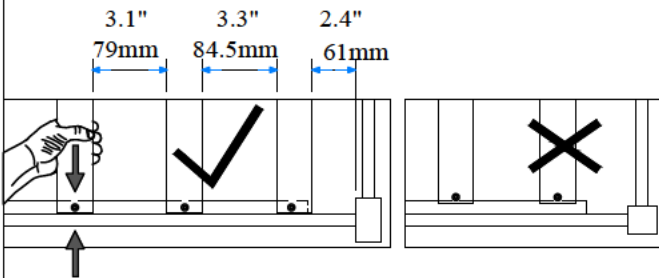
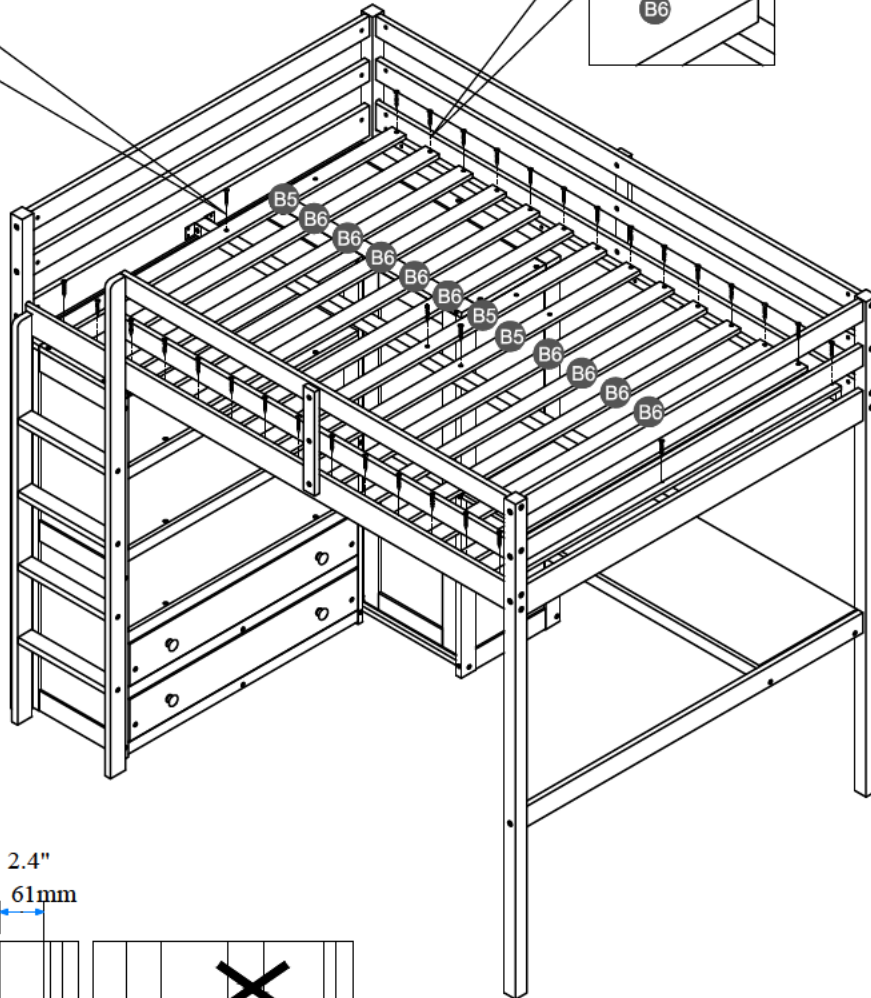
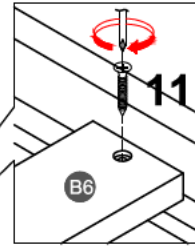
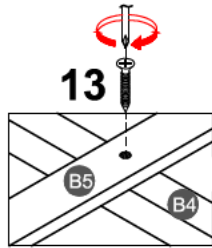

**NOTE:** Please make sure the bed slats close to the side rail before locking the screws to avoid breakage. This step is required for both the left and right sides. Moreover, please do not lock the screws of the bed slats at the outermost edge to avoid damaging.

**Remarque:** Assurez-vous Les lattes du lit fermer du rail latéral avant de verrouiller les vis pour éviter la casse. Cette étape est requise pour tous les deux côtés gauche et droit. De plus, ne verrouillez pas les vis des lattes de lit sur le bord le plus extérieur pour éviter d'endommager.

**Make sure to tighten all the screws of the bed.**

**Assurez-vous de serrer toutes les vis des de lit.**