

ASSEMBLY INSTRUCTIONS & PARTS IDENTIFICATION

Hardware Kit (1936-32P01)

No.	Qty	Description
A	8 pcs	Hex Bolt $\varnothing 5/16"$ x2"
B	8 pcs	Flat Washer $\varnothing 5/16"$ x22x1.2mm
C	8 pcs	Lock Washer $\varnothing 5/16"$
D	1 pc	Wrench $\varnothing 12.8$ mm

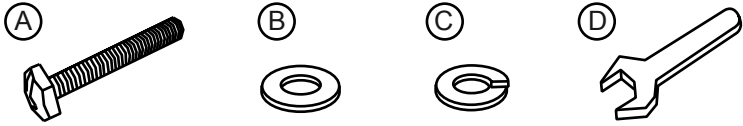

Parts Key

No.	Code	Qty	Description
1	1936-32P02	4 pcs	Leg
2	1936-32P24	1 pc	Table Top
3	1936-32P26	4 pcs	Corner Block
4	1936-32P01H	6 pcs	Hinge
5	1936-32P28	2 pcs	Drop Leaf
6	1936-32P36	4 pcs	Drop Leaf Support
7	1936-32P01F	4 pcs	Floor Glide
8	1936-32P36W	4 pcs	Drop Leaf Support Wedge
9	1936-32P36G	4 pcs	Drop Leaf Support Guide

Step 1:

Turn the table top upside down on a protective surface such as carpet or other soft material. Place the leg to the corner of the apron. Insert the **Flat Washer**, **Lock Washer** and **Hex Bolt** into pre-drilled holes on the corner block and tighten it by using the **Wrench** provided. Repeat for each legs.

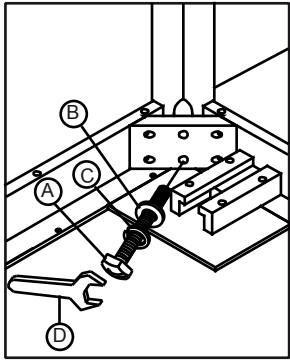

Detail A

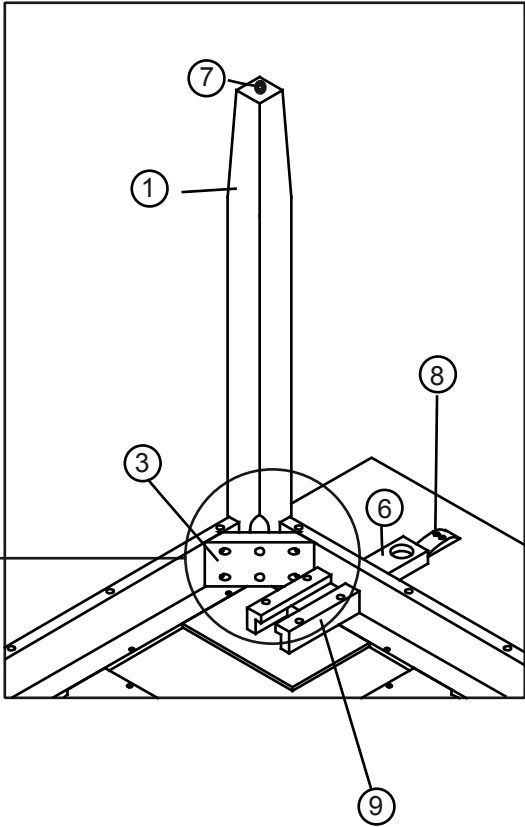

Step 2:

Set table upright on its legs.

