





Assembly Instructions

Thank you for purchasing this quality product. Please read instructions thoroughly before unpacking assembly parts.

Caution: Sharp, exposed staple tips can cause injure. Therefore, for your protection, please remove any exposed staples used in packing.

Please keep all hardware parts out of the reach of children.

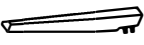
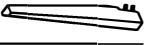
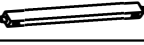
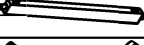
1. We recommend that you should assemble this product with the assistance of another person; this will make assembly easier and will help to prevent personal injury and to insure parts are not damaged during assembly process.
2. Before beginning, please check packing materials carefully for small parts that may have come loose inside the carton during shipping. Do not discard any packing material until all parts have been located. If any parts are missing, please contact your dealer for prompt replacement.
3. To prevent damage to your floor or carpet, please check the bottom of each piece of furniture for stain residues and rough surface and also check for staples or nail left after removing the packing materials. The manufacturer will not be held responsible if preventive steps are not taken prior to installation.
4. Please do not over tighten screws or bolts. During normal use everyday screws, bolts, nuts and wooden plugs may loosen up. They should be periodically inspected and re-tightened to prevent damage to the furniture and (or) personal property or cause injury. Always check to be sure all hardware on this list and below mentioned components are attached to the furniture properly and kept tightened.
5. Please lay all parts and hardware on a non-abrasive surface such as a carpet and follow the assembly.

NO.	SKETCH	PARTS LIST	Q' ty
A		Back Rest	1
B		Cushion Seat	1
C		Front Left Leg	1
D		Front Right Leg	1
E		Left Side Stretcher	1
F		Right Side Stretcher	1
G		Left Arm Chair	1
H		Right Arm Chair	1

NO.	HARDWARE LIST	Q' ty
1	 JCBC $\varnothing 1/4'' \times 38\text{mm}$	6
2	 JCBC $\varnothing 1/4'' \times 70\text{mm}$	4
3	 $\varnothing 1/4'' - 13\text{mm}$ Spring washer	10
4	 $\varnothing 1/4'' - 19\text{mm} \times 2\text{mm(T)}$ Flat washer	10
5	 Nut $\varnothing 5/16'' \times 12 \times 6\text{mm(W027)}$	4
6	 $\varnothing 5/16'' - 13\text{mm}$ Spring washer	4
7	 $\varnothing 5/16'' - 19\text{mm} \times 2\text{mm(T)}$ Flat washer	4
8	 Screw $\varnothing 8 \times 32\text{mm}$	6
9	 Allen Key (4mm)	1
10	 Wrench (12.8mm)	1

TIP: Store the Allen key and Wrench in assembly in this product drawer or use masking or painter tap to affix it to the underside of the product. This will make it easier to find if you want to periodically tighten bolts or disassemble the product.

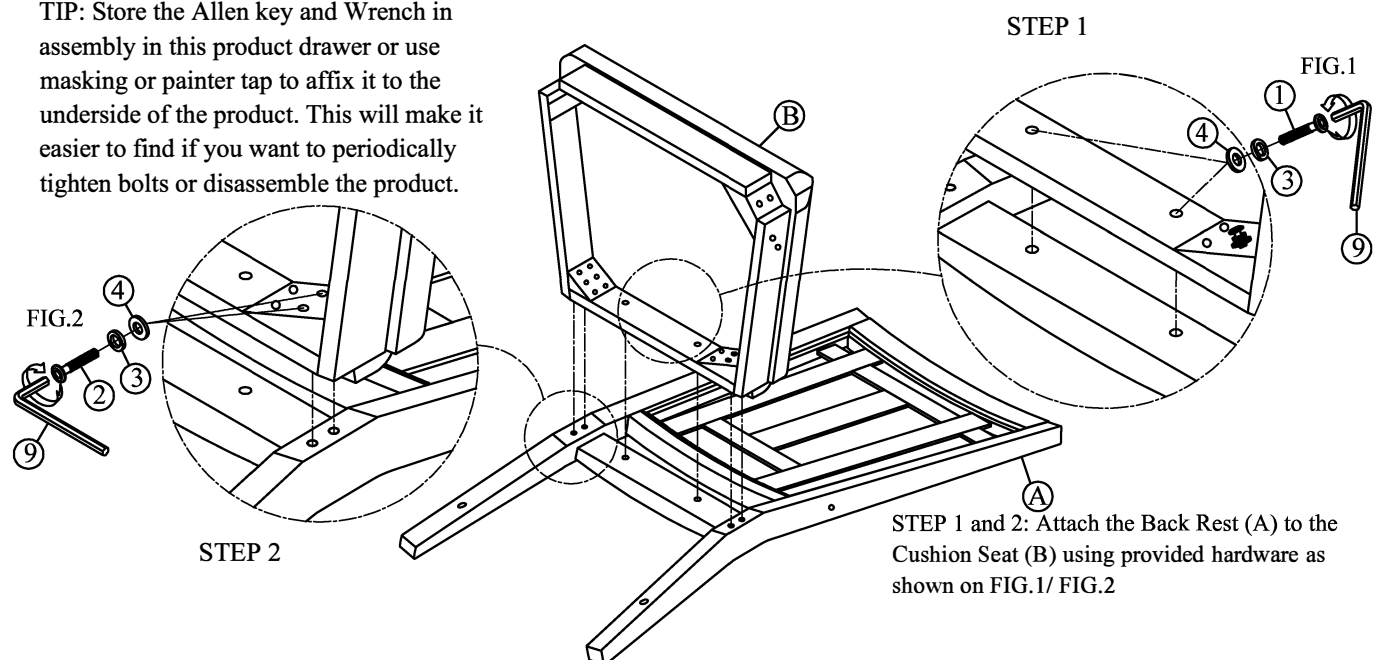

Assembly Instructions

STEP 4

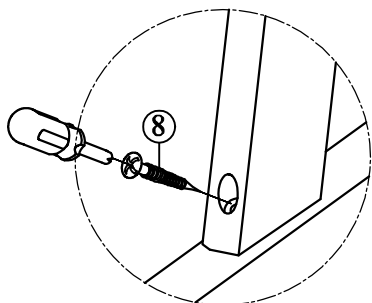

FIG. 4

STEP 3: Attach Front Legs (C) & (D) to the corner blocks of Cushion Seat (B) using provided hardware as shown on FIG.3

STEP 3

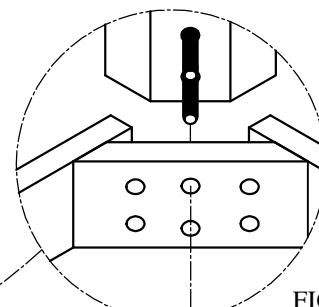

FIG. 3

STEP 4: Attach the Side Stretcher (E) & (F) to the Front Leg (C) & (D) and to the Back Rest (A) using provided hardware as shown on FIG.4.

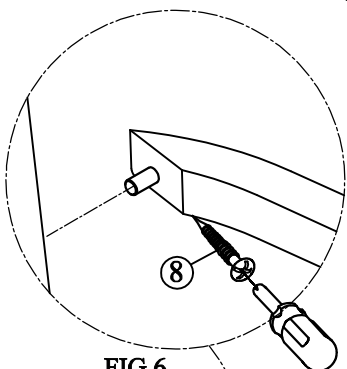
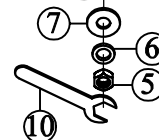
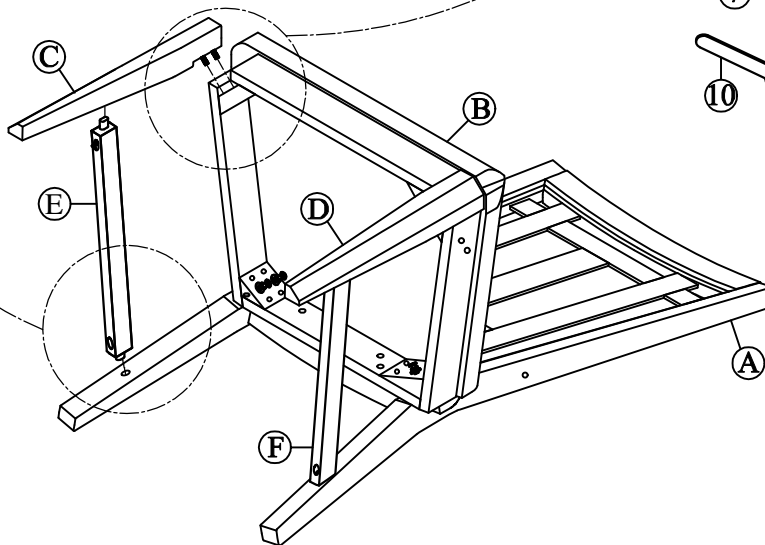

FIG. 6

STEP 5: Attach Right & Left Chair Arms (H) & (G) to the Cushion Seat (B) and Back Rest (A) using screws as shown on FIG.5/FIG.6.

STEP 5

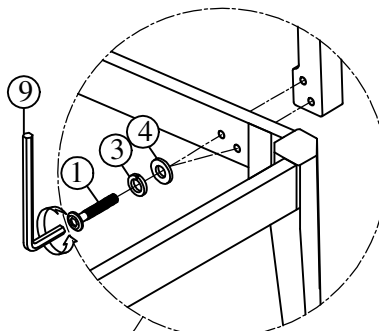
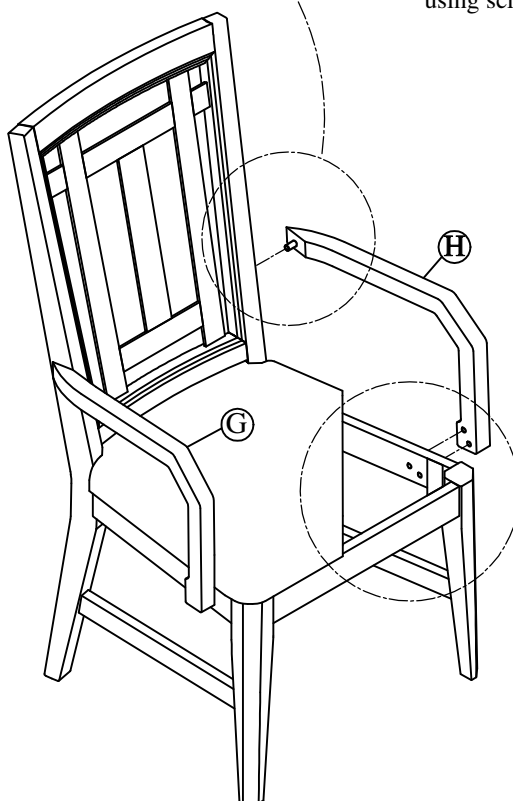
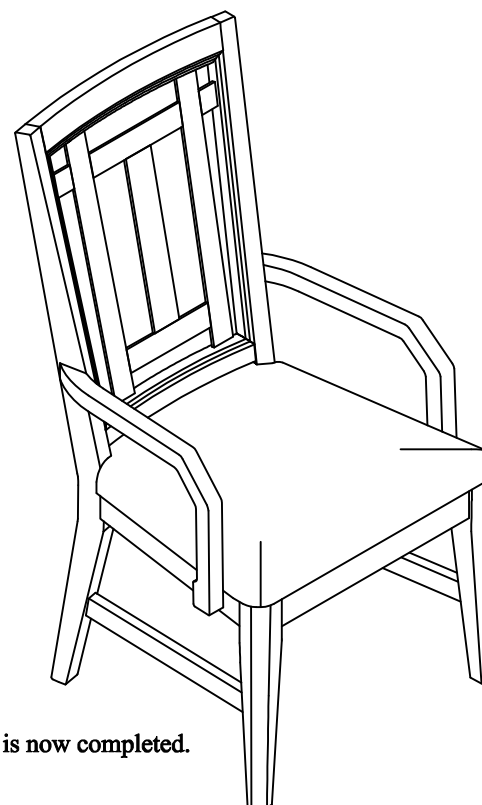

FIG. 5



STEP 6: Turn the Chair to standing position. Check it's balance and tighten all screws and bolt to complete assembly.



Assembly is now completed.