

1. Prepare Tap for Installation

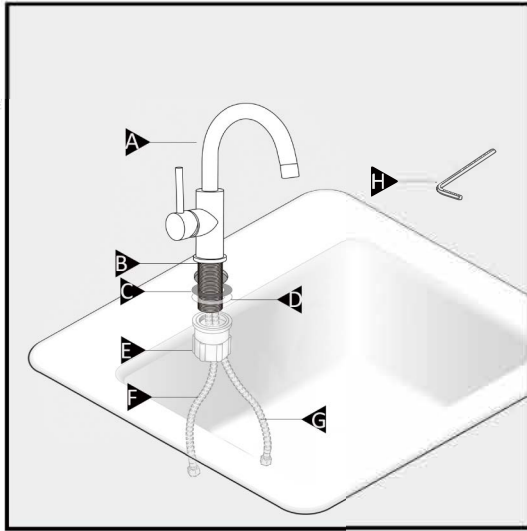

1.Parts List

- A: Tap Body
- B: Fixed Bolt
- C: Rubber Washer[a]
- D: Rubber Washer[b]
- E: Mounting Nut
- F: Hot Water Hose
- G: Cold Water Hose
- H: Hexagon Wrench

2.Tools Required (Not Included)

- 1.Safety glasses
- 2.Phillips screwdriver
- 3.Adjustable Wrench
- 4.Cloth

3.Tips

1. Working water pressure at 0.3-1.5 MPA.
2. For protecting the service life, it is not allowed to touch or cut with sharp tool.

4.Caution — Tips for removal of old tap:

Always turn water supply OFF before removing existing tap or disassembling the valve. Open tap handle to relieve water pressure and ensure that complete water Shut-off has been accomplished

Icon Legend



Above sink

Blow sink

5.Remarks

- 1: Without affecting their performance, accessories may be changed without further notice.
- 2: Drawing for reference only, product size & shape refer to actual faucet.
- 3: Thanks for choosing our product.

2. Installation Instructions

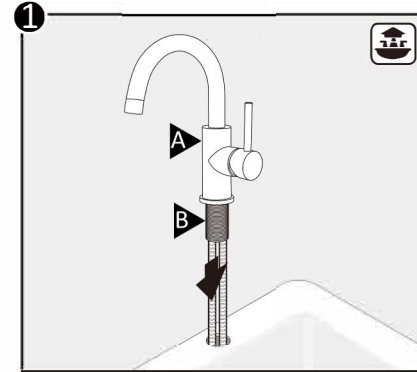

- 1.Install fixed bolt(B), hot water pipe (F) and cold water pipe (G) to the tap body
- 2.Install tap body (A) in hole on sink.

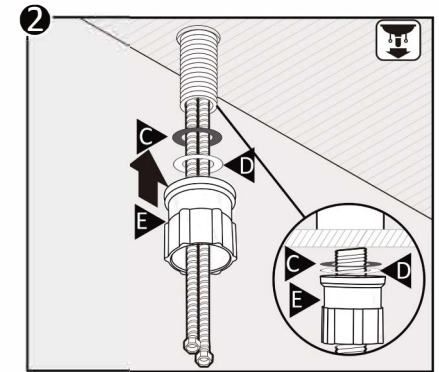

- Mounting rubber washer [a](C) and rubber washer [b](D) up onto tap body (A) under sink and secure with mounting nut (E).

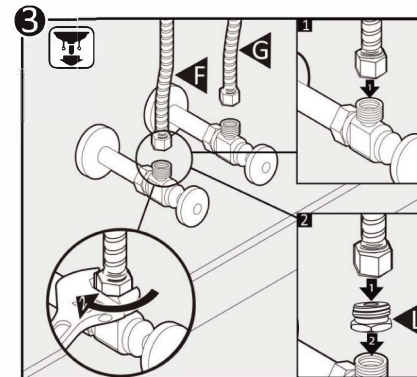

- 1.Attach flexible supply line(F, G) to the shut off valves.
- 2.Tighten with a wrench.

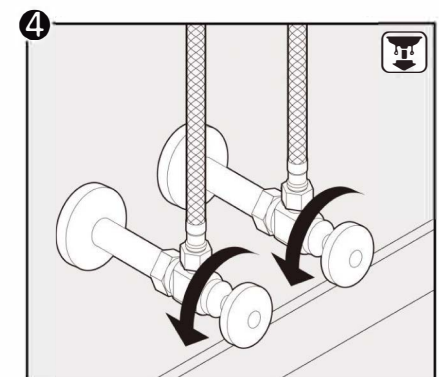

- 1.Attach the water supply lines in a conspicuous location.
- 2.Turn on Hot (F) and Cold (G) water supply to check for leaks

3. Check

1. After installation is completed, turn on the hot and cold water supply. Check for leaks.
2. Turn the faucet on to the warm position where it mixes hot and cold water. Flush line for one minute. Check for leaks.

Notice: Re-tighten any connections if necessary, but do not over tighten.

4. Cleaning & Maintenance

To keep the product clean & shining, follow as below.

- 1: Flush with clean water & dry with soft cloth only.
- 2: If any dirt, clean with soft liquid or transparent glass detergent.
- 3: Do not use any scrubbing detergent, polisher, sand-cloth, paper tissue or scraper.
- 4: Do not use acid detergent, indissoluble grain-like detergent or soap.

5. Return Policy

If you want to return the product after purchasing:

- 1: Please return the product to the warehouse as a whole with product parts not being lost and packing box intact when you want to return this product for personal reasons.
- 2: Please attach a piece of paper in the returned package and indicate the quality problem so that the working staff could acknowledge that this product shall not be for secondary sales when you want to return this product due to quality problems.
- 3: If it is convenient to you, we hope you can send the picture of the faucet to us, if the faucet has any quality problem. Since our products are high value products, we need more feedback to improve our products.

6. Warranty

The distributor warrants to the original purchaser of this product to be free from defects in material and workmanship under normal use in residential applications. At its option, the Company will provide repair parts or replace defective product when the product is used in accordance with the manufacturer's specifications.

The distributor provides a limited 5-year warranty on the finish of this product to the original purchaser. At its option, the distributor will provide repair parts or replace defective product when the product is used in accordance with the manufacturer's specifications.

This warranty is not applicable to any products or parts of products where damage is caused by use of non-genuine parts; is due to installation error, product misuse, negligence or faulty maintenance.

This warranty excludes labor charges or damage incurred during installation, repair or replacement, and any indirect, incidental or consequential damages, losses, injury or costs of any nature.

Leading Global Healthy Life

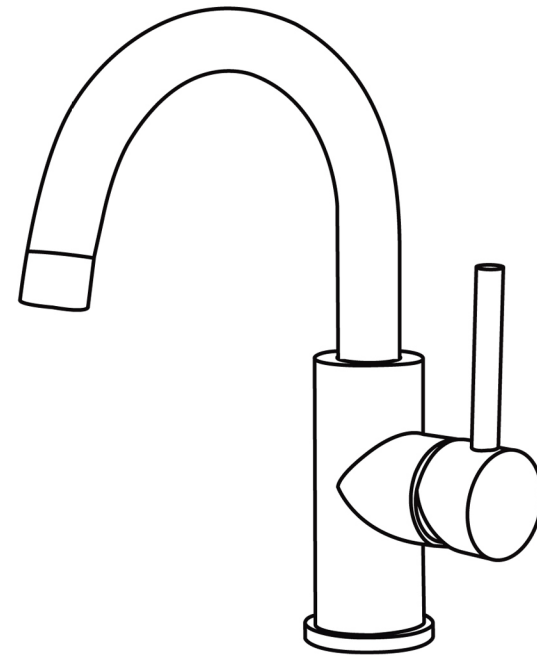

**Faucet Instruction
&
After-sales Service**