

Please read the assembly instructions carefully.
There are two sofa types: ① and ②
You can choose ① or ② to assemble according to your needs.

Assembly Option ①

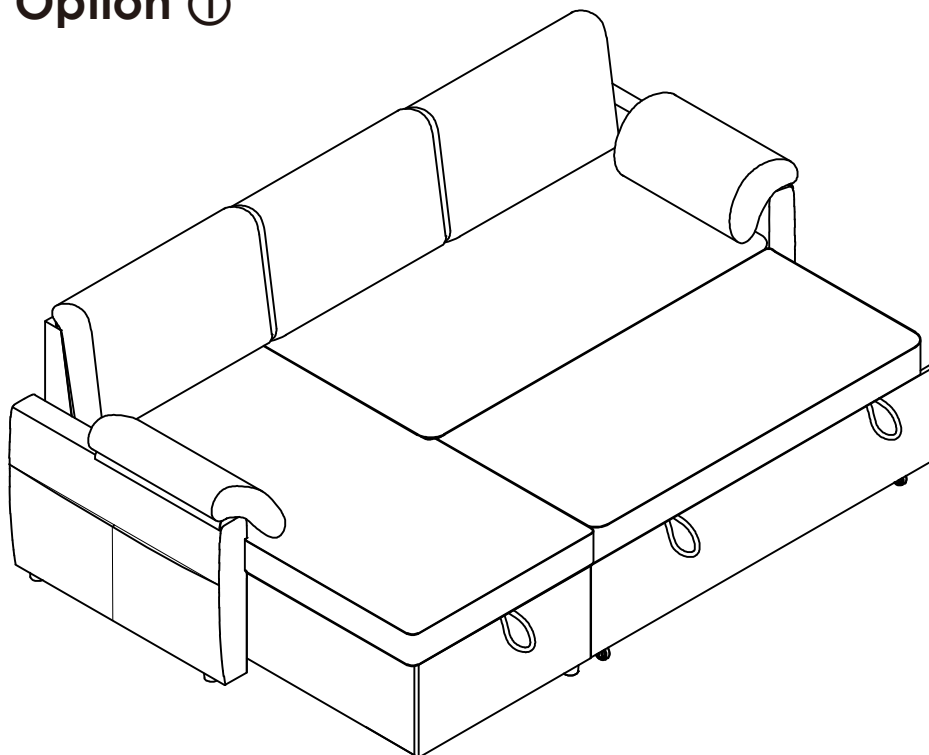

Assembly Option ②

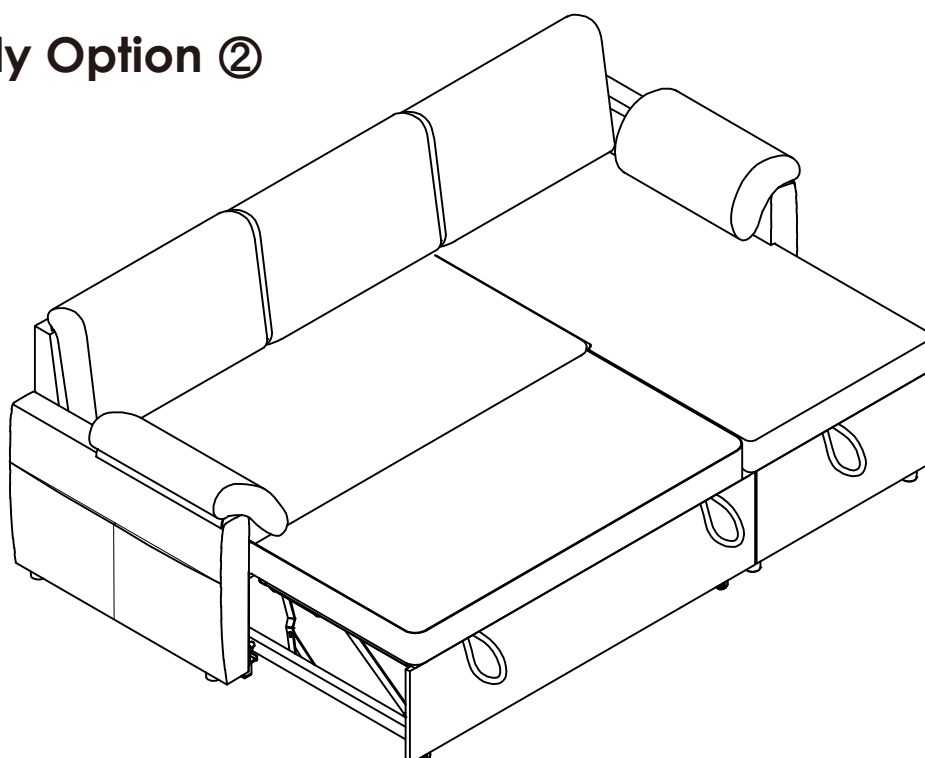

Main Structure Accessories

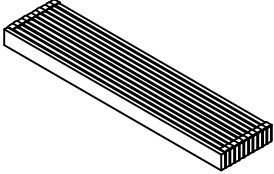
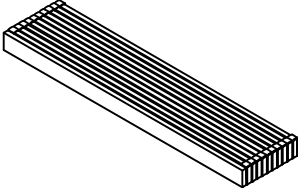
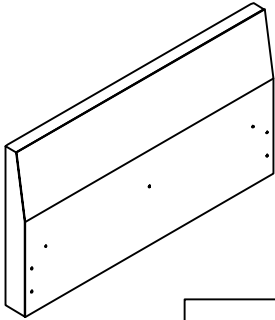
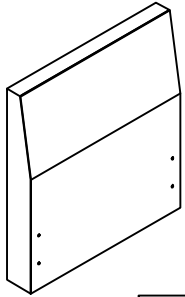
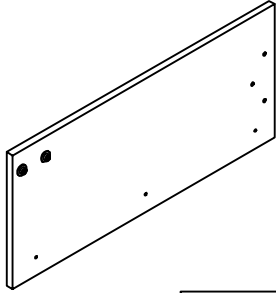
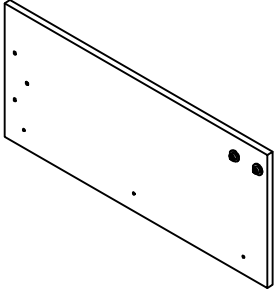
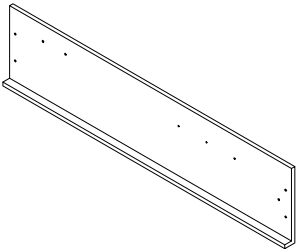
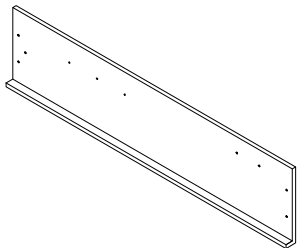
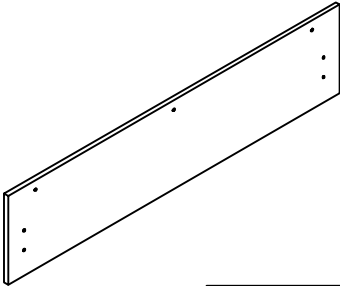
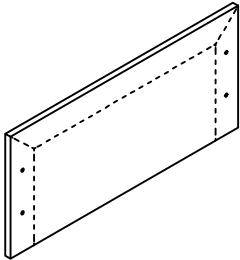
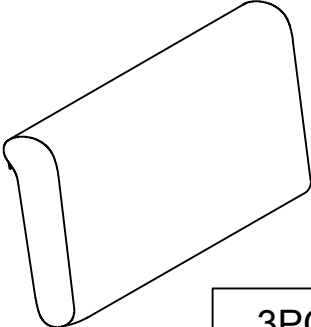
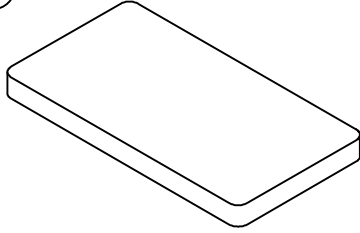
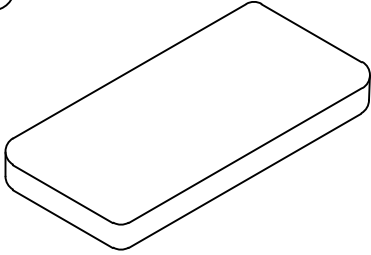
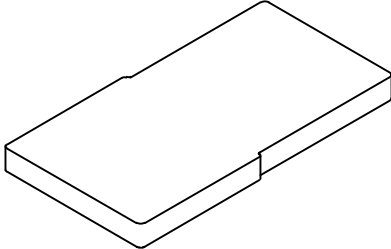
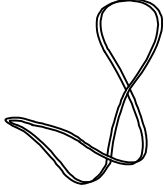
<p>(A)</p>  <p>2PCS</p>	<p>(B)</p>  <p>1PC</p>	<p>(C)</p>  <p>1PC</p>
<p>(C1)</p>  <p>1PC</p>	<p>(D)</p>  <p>1PC</p>	<p>(D1)</p>  <p>1PC</p>
<p>(D2)</p>  <p>1PC</p>	<p>(D3)</p>  <p>1PC</p>	<p>(E)</p>  <p>1PC</p>
<p>(E1)</p>  <p>1PC</p>	<p>(F)</p>  <p>3PCS</p>	<p>(F1)</p>  <p>1PC</p>
<p>(F2)</p>  <p>1PC</p>	<p>(F3)</p>  <p>1PC</p>	<p>(F4)</p>  <p>short</p> <p>1PC</p>

Main Structure Accessories

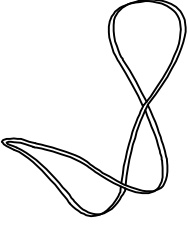
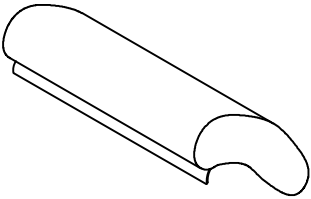
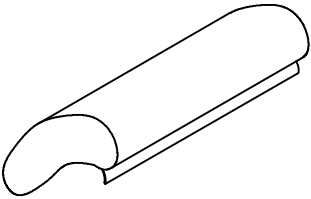
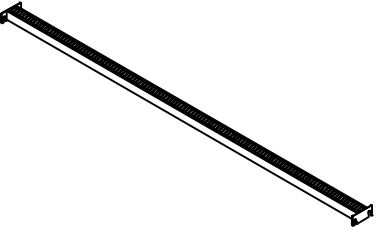
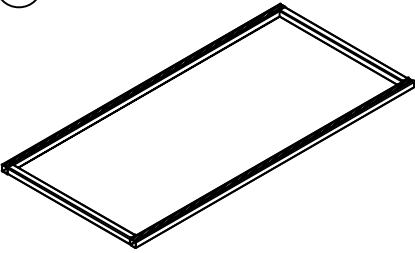
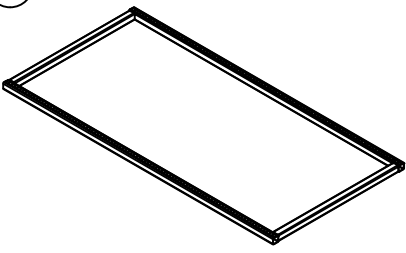
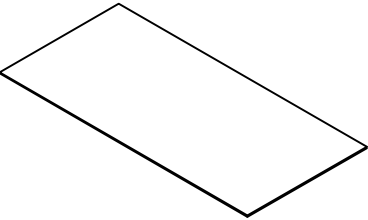
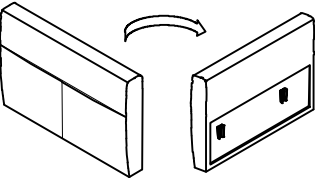
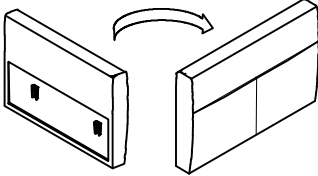
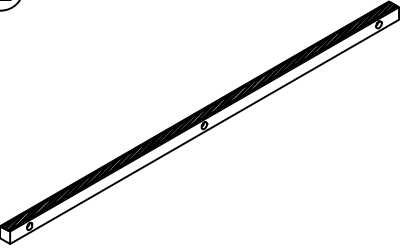
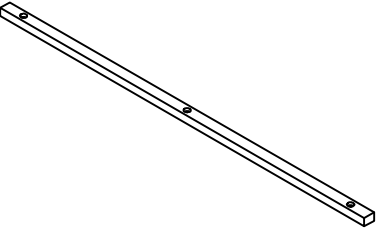
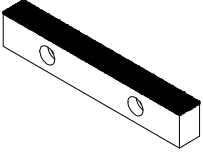
<p>F4 -1</p>  <p>long</p> <p>2PCS</p>	<p>F5-R1</p>  <p>1PC</p>	<p>F5-R2</p>  <p>1PC</p>
<p>G</p>  <p>1PC</p>	<p>H</p>  <p>1PC</p>	<p>H1</p>  <p>1PC</p>
<p>Q</p>  <p>1PC</p>	<p>R1</p>  <p>1PC</p>	<p>R2</p>  <p>1PC</p>
<p>Z</p>  <p>1PC</p>	<p>Z1</p>  <p>1PC</p>	<p>Z2</p>  <p>2PCS</p>

Structural Accessories

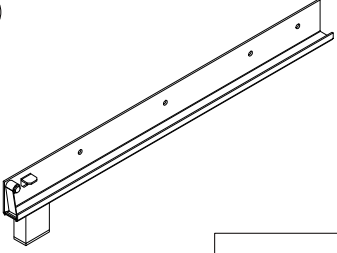
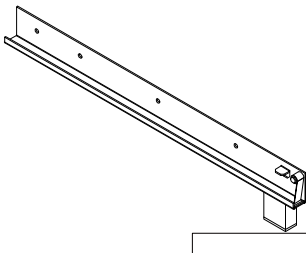
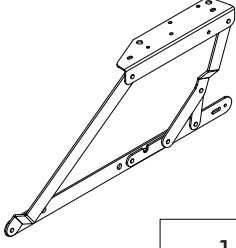
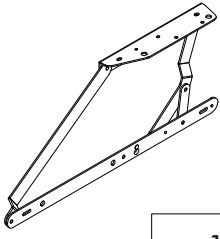
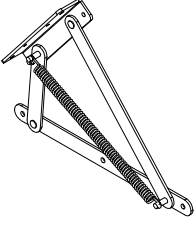
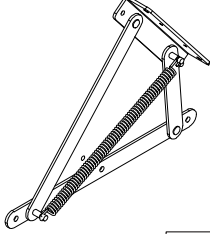
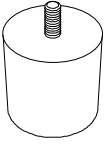
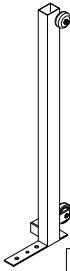
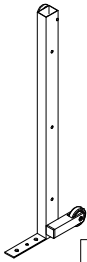
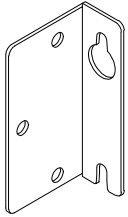
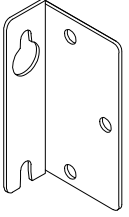
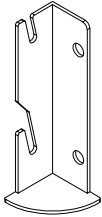
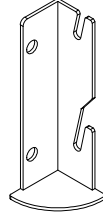
<p>J</p>  <p>1PC</p>	<p>J1</p>  <p>1PC</p>	<p>K</p>  <p>1PC</p>	
<p>K1</p>  <p>1PC</p>	<p>L</p>  <p>1PC</p>	<p>L1</p>  <p>1PC</p>	
<p>M</p>  <p>10PCS</p>	<p>S</p>  <p>1PC</p>	<p>S1</p>  <p>1PC</p>	<p>W</p>  <p>2PCS</p>
<p>X</p>  <p>2PCS</p>	<p>W1</p>  <p>1PC</p>	<p>X1</p>  <p>1PC</p>	

Hardware Parts

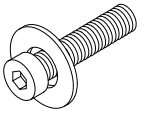
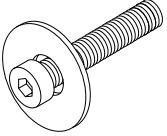
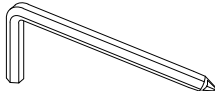
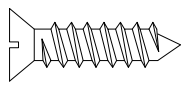
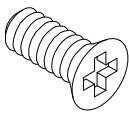
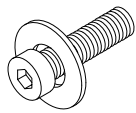
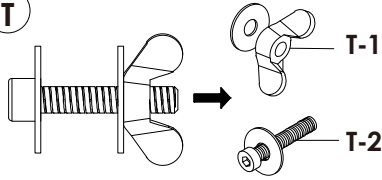
<p>N Small gasket</p>  <p>M8×30mm 10+2PCS</p>	<p>N1 Large gasket</p>  <p>M8×45mm 2PCS</p>	<p>P</p>  <p>1PC</p>	<p>U</p>  <p>M5×14mm 8+1PCS</p>
<p>V</p>  <p>M6×17mm 20+1PCS</p>	<p>Y</p>  <p>M8×18mm 6PCS</p>	<p>T</p>  <p>M8×50mm 1SET</p>	

Main Structure Accessories

CHAISE

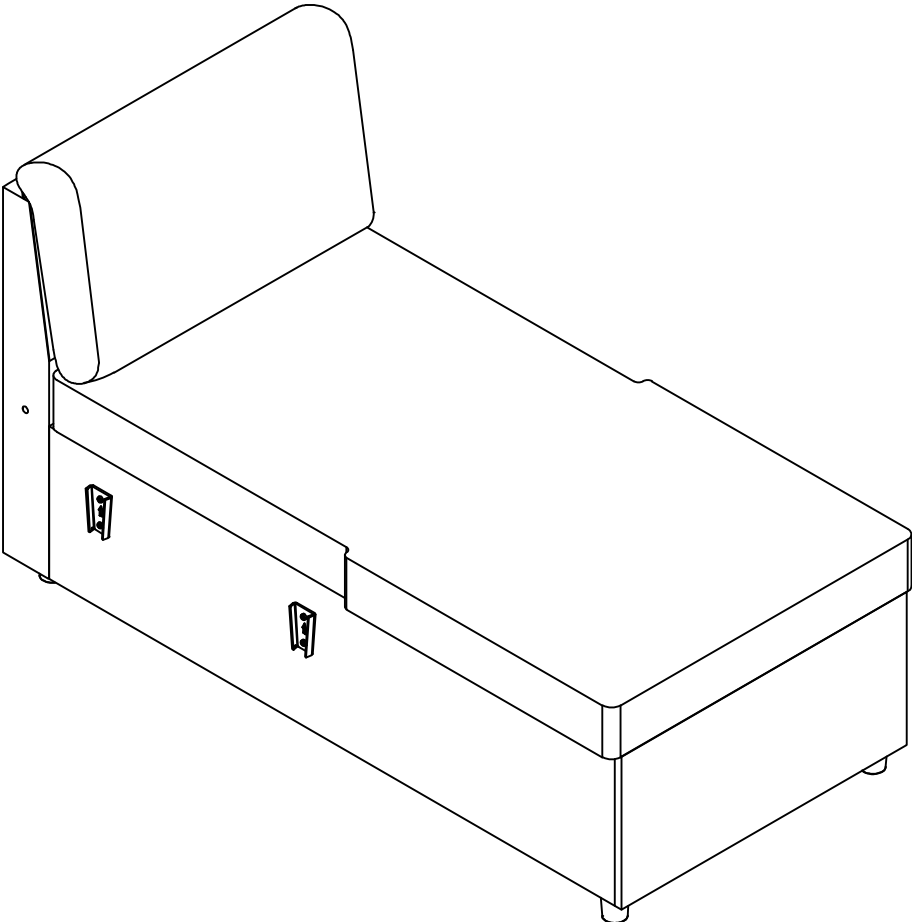
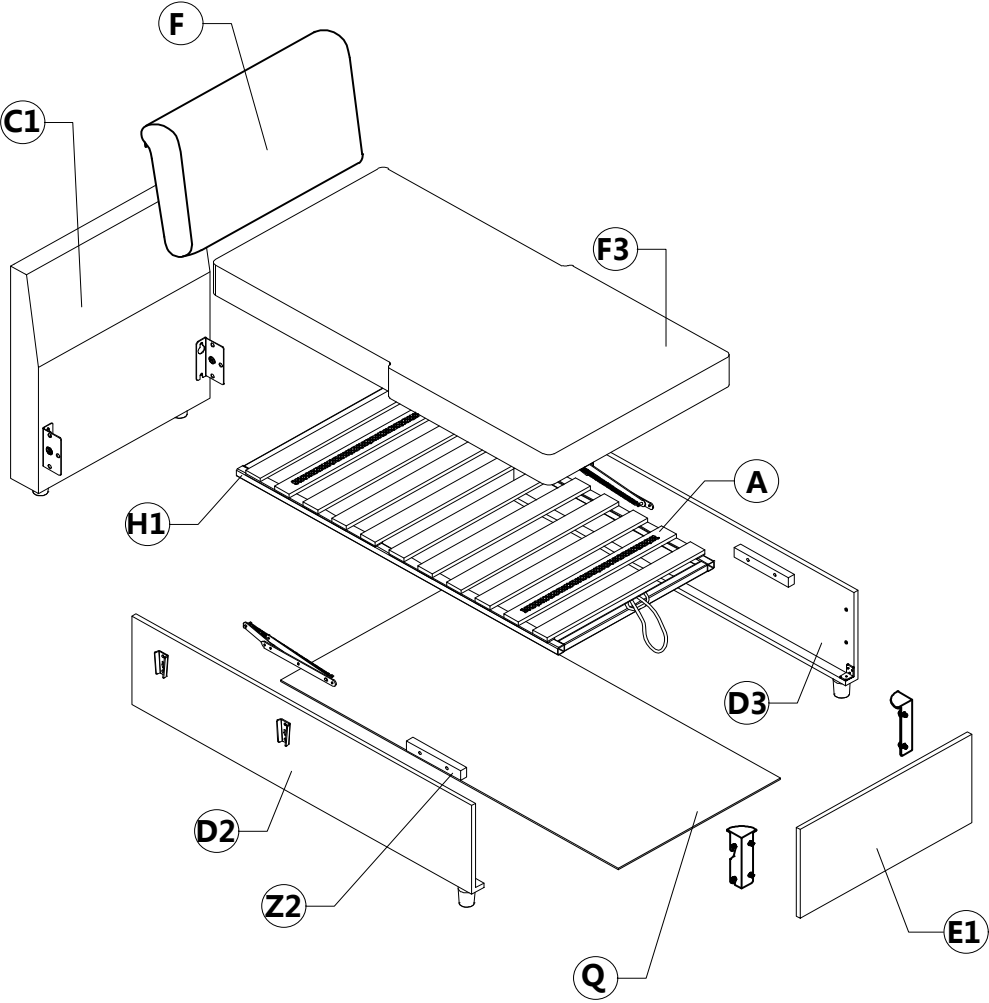



Assembly Steps(EN) / Montageschritte(DE)

STEP 1

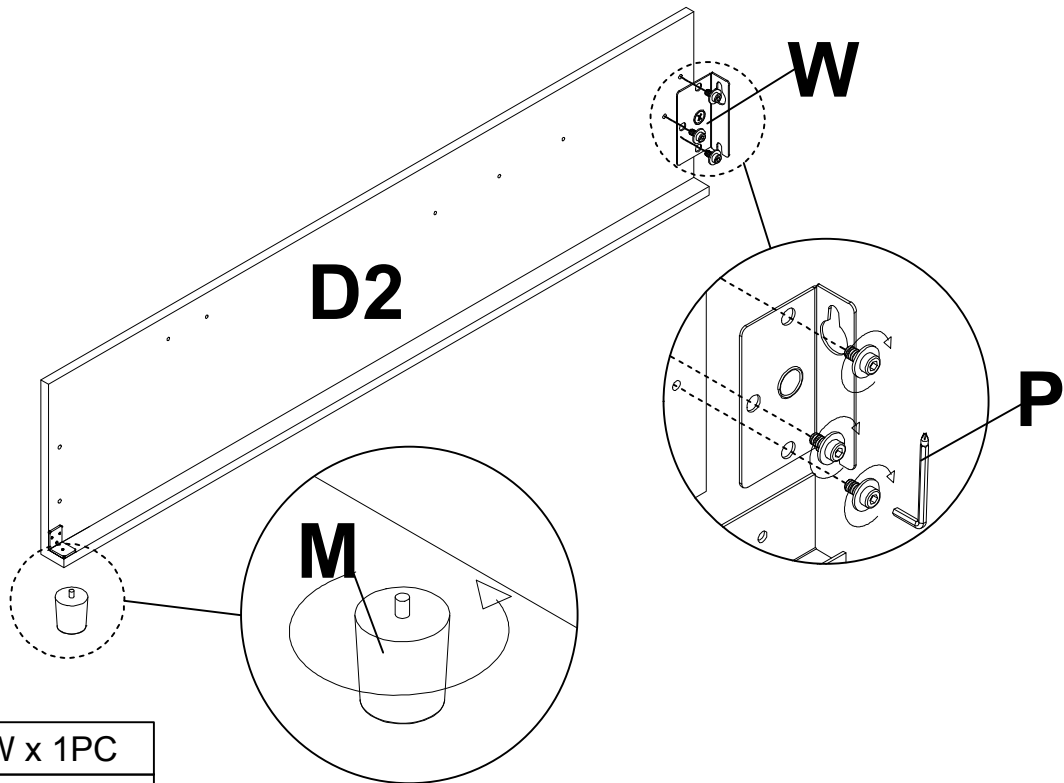
Loosen the screws first, and then lock the hanging piece
Pay attention to the opening up on the side near the foot post





	W x 1PC
	P x 1PC

STEP 2

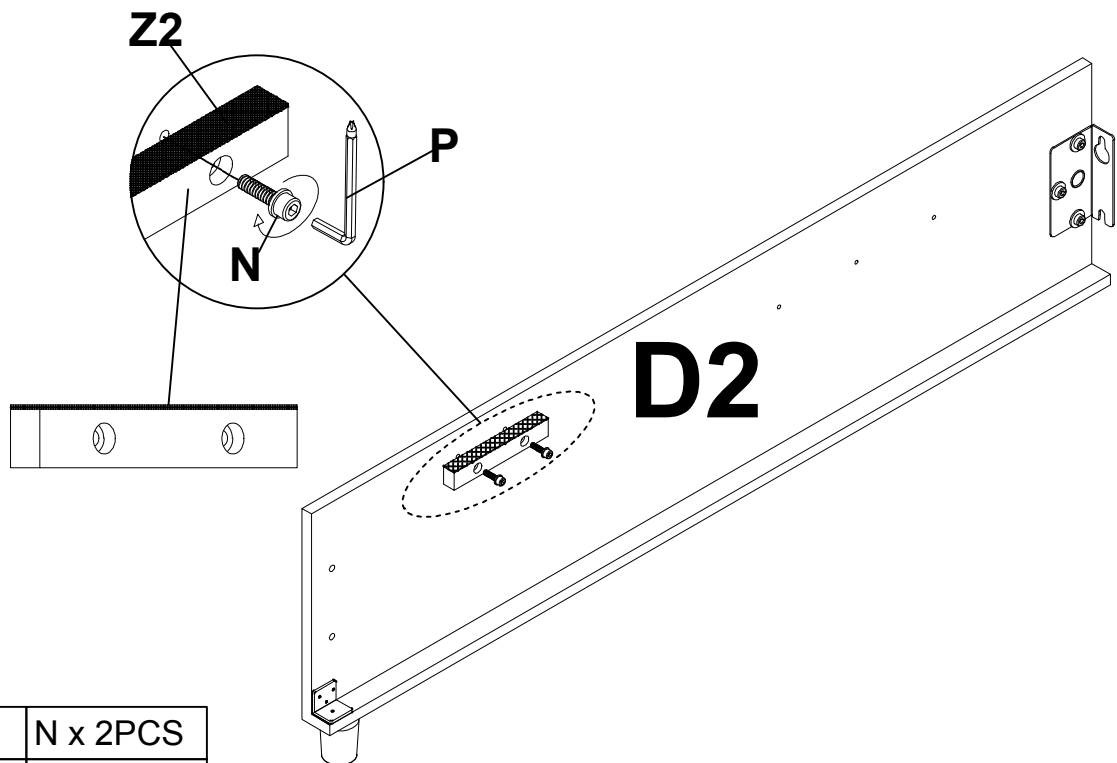
Note that the countersink hole faces outward
and the EVA non-slip sticker faces upward when installing





	N x 2PCS
	P x 1PC

Assembly Steps(EN) / Montageschritte(DE)

STEP 3

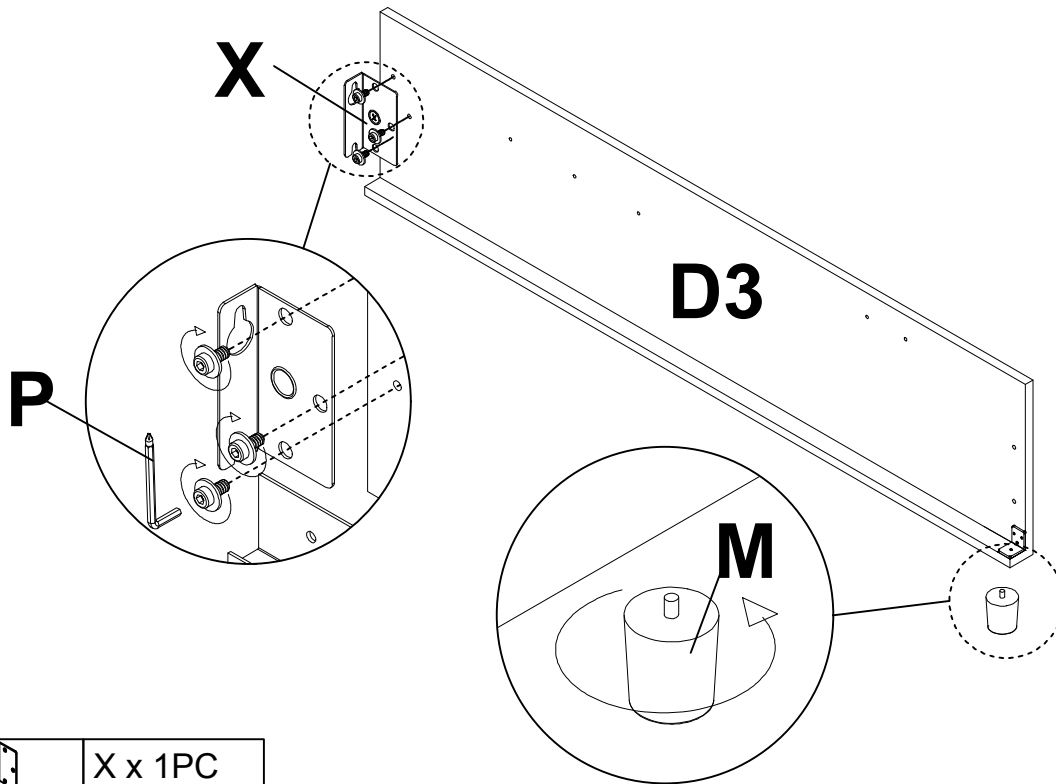
Loosen the screws first, and then lock the hanging piece
Pay attention to the opening up on the side near the foot post





	X x 1PC
	P x 1PC

STEP 4

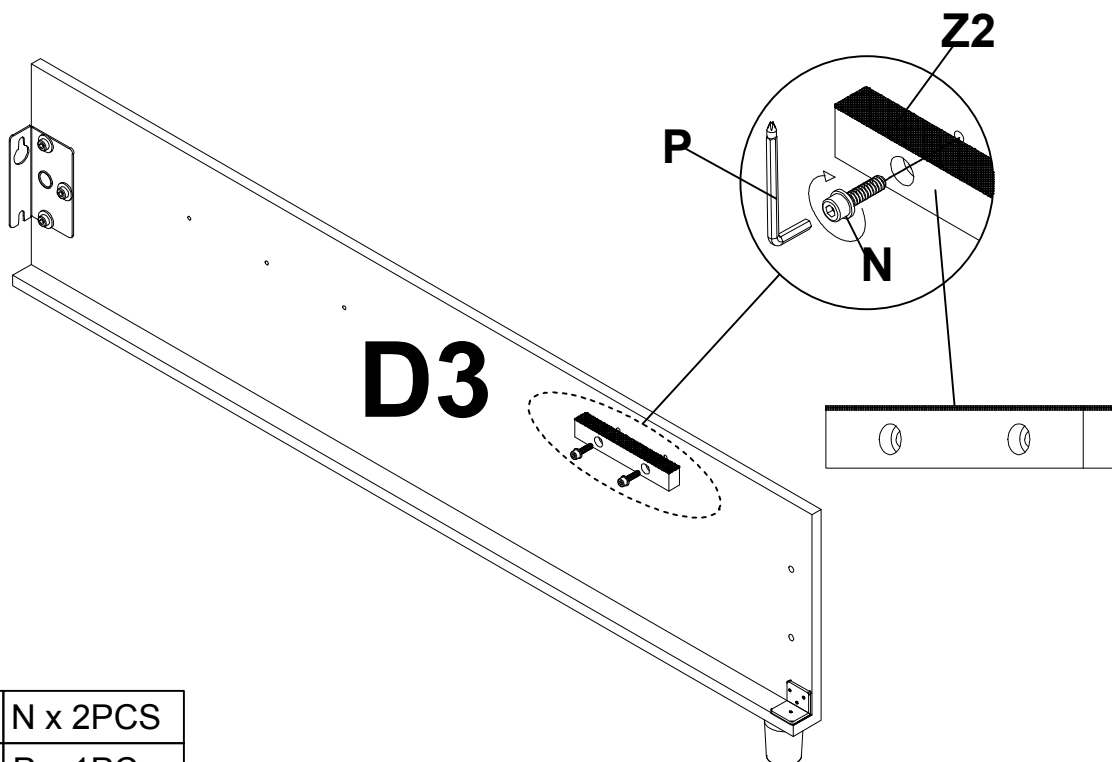
Note that the countersink hole faces outward
and the EVA non-slip sticker faces upward when installing



	N x 2PCS
	P x 1PC

Assembly Steps(EN) / Montageschritte(DE)

STEP 5

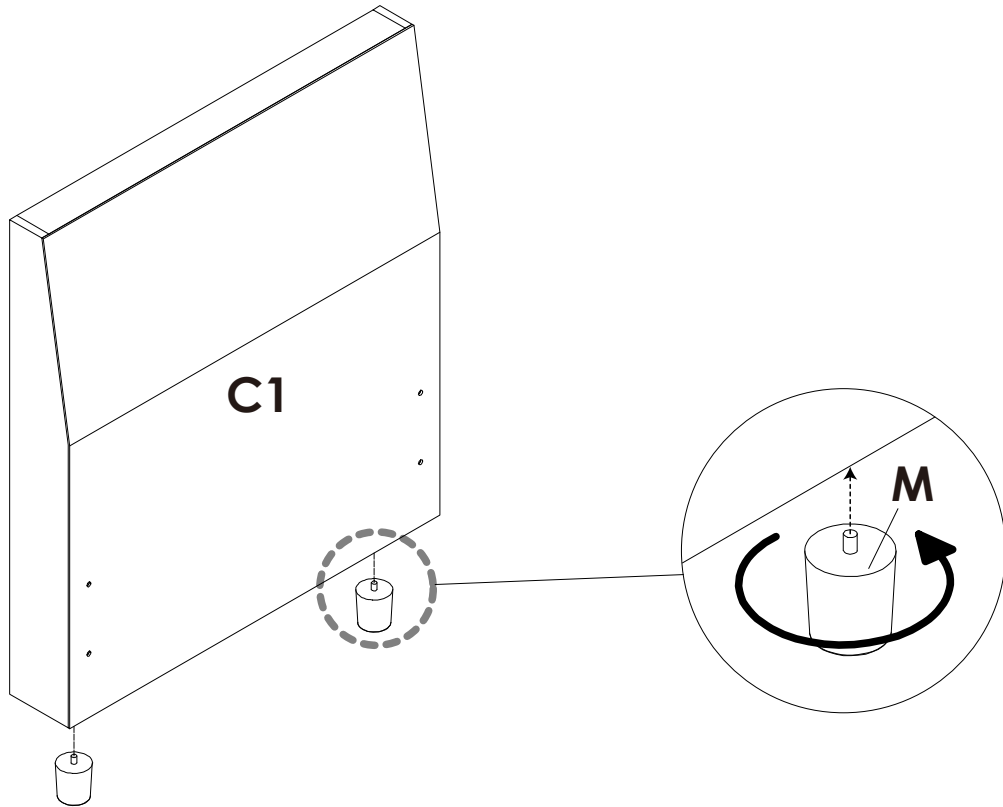

STEP 6

First loosen the screws, install the mounting plate, and then lock the screws.

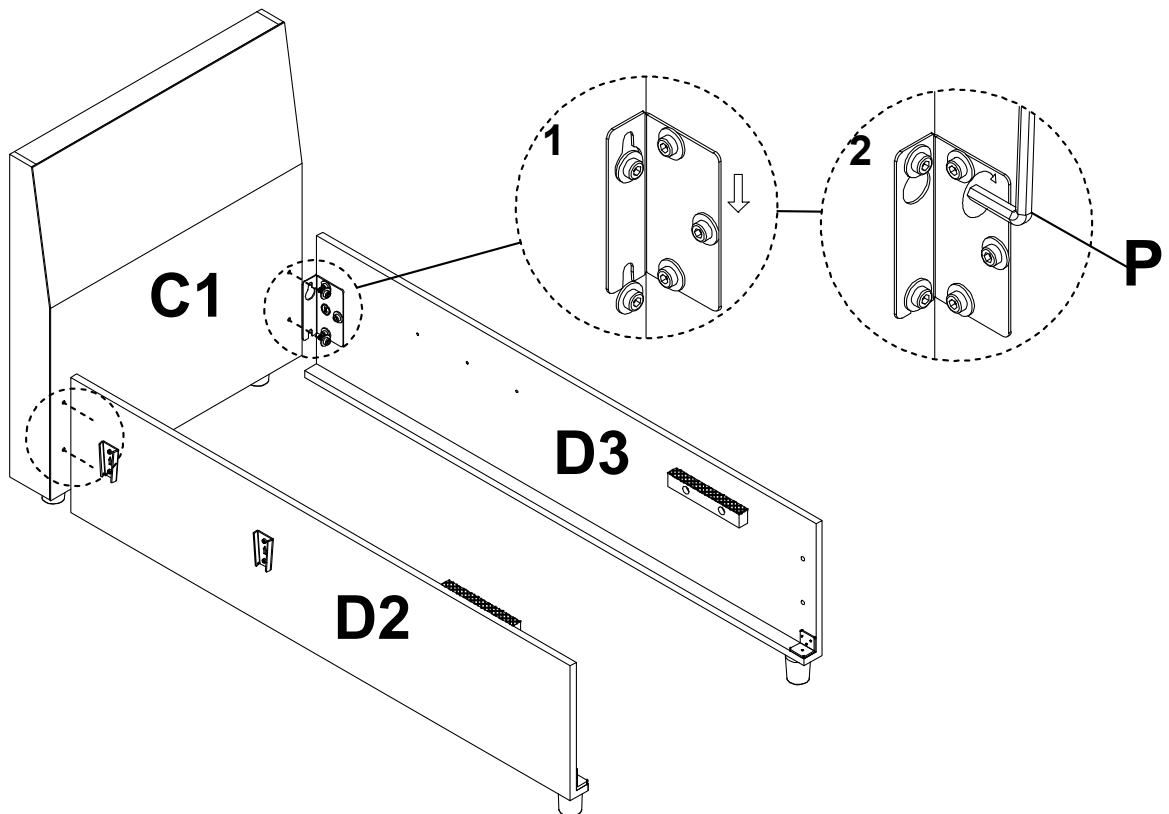

P x 1PC

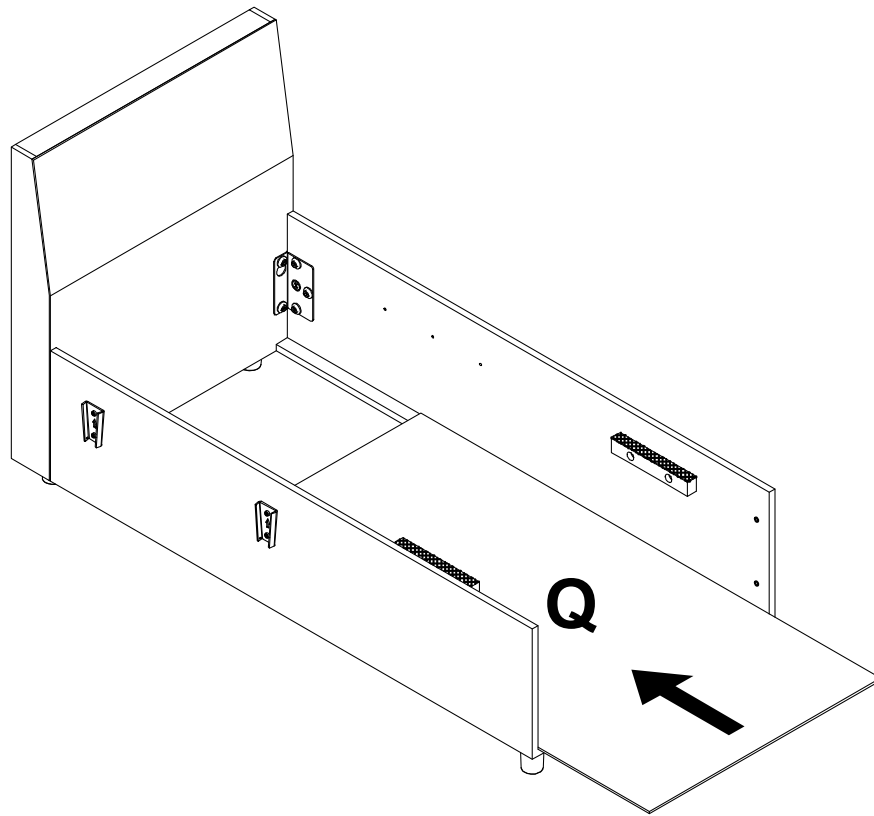

Assembly Steps(EN) / Montageschritte(DE)

STEP 7

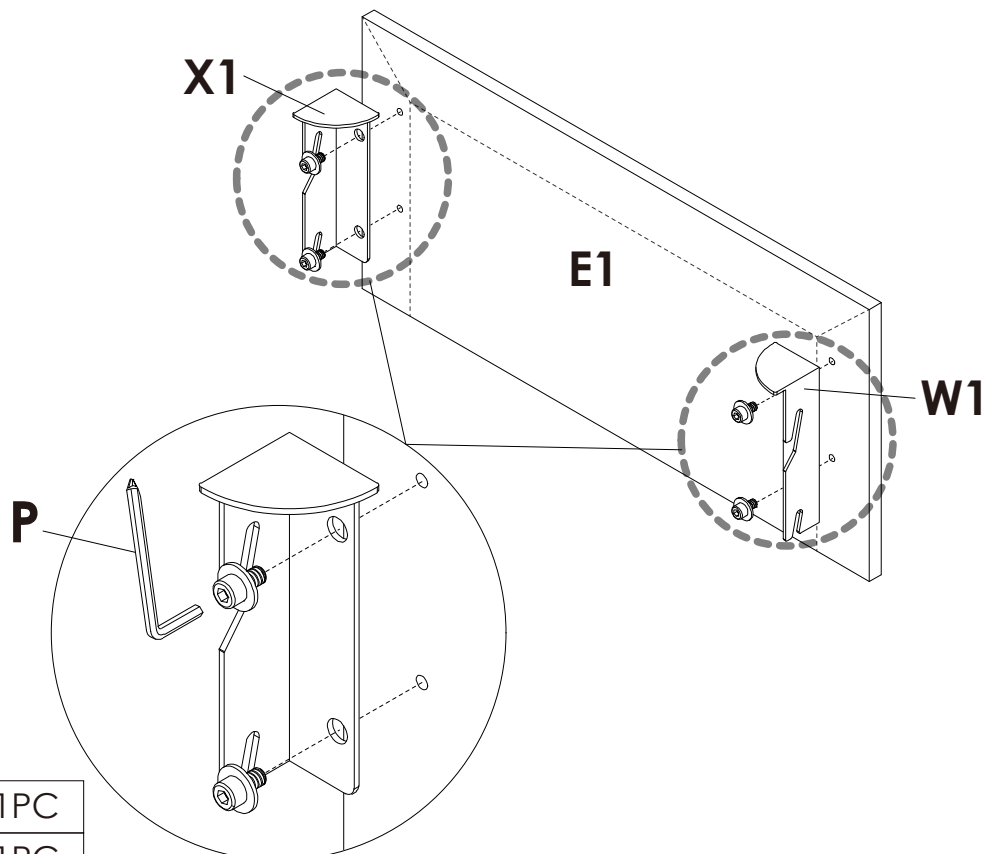

STEP 8



	W1 x 1PC
	X1 x 1PC
	P x 1PC

Assembly Steps(EN) / Montageschritte(DE)

STEP 9

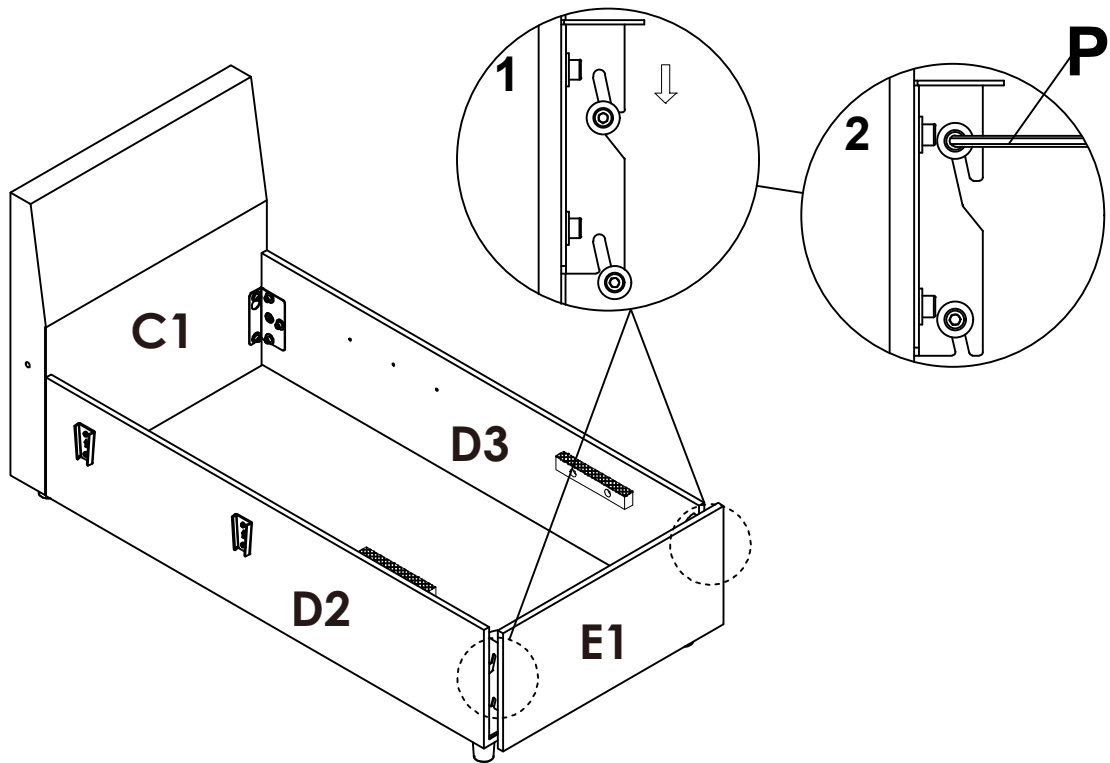

P x 1PC

STEP 10

Note: The accessories should be distinguished between left and right, and the screws should be tightened after installation.

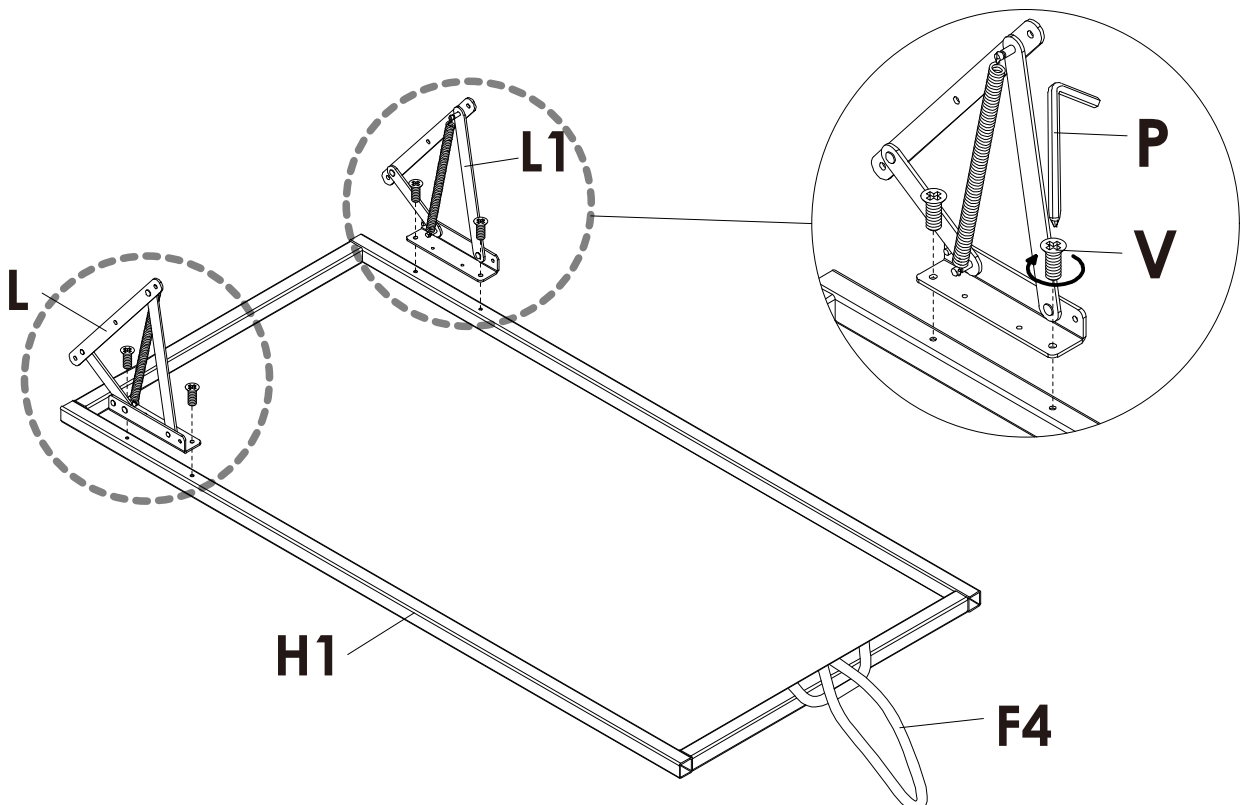

V x 4PCS



P x 1PC

Assembly Steps(EN) / Montageschritte(DE)

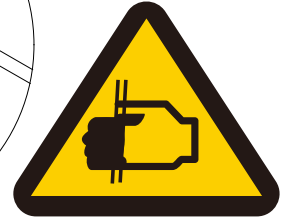
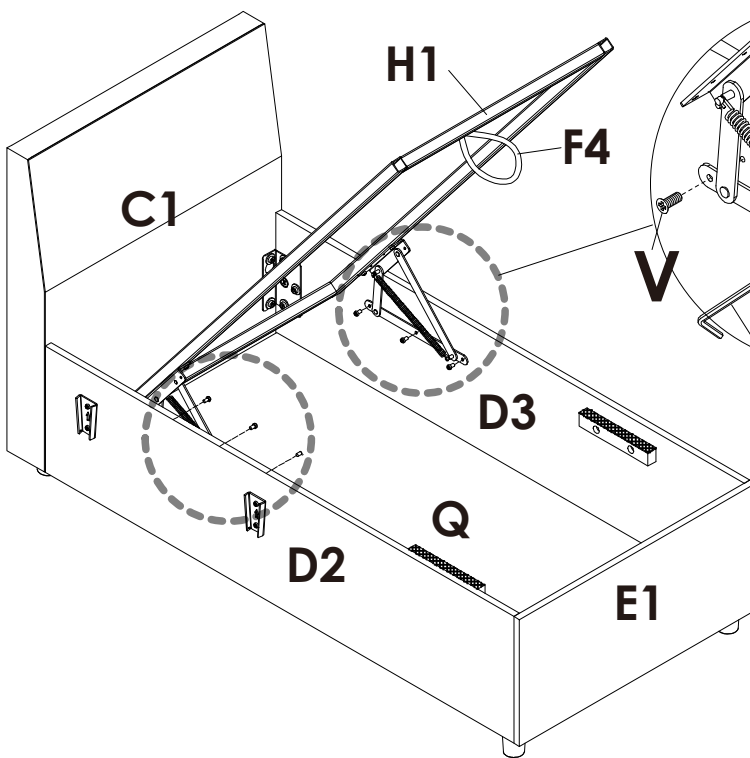

STEP 11

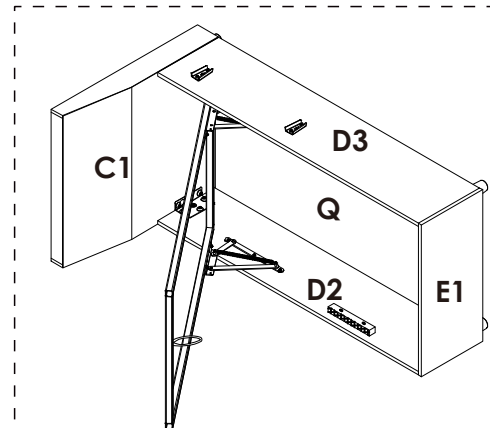

WARNING:HANDS PINCHING



Note:Easier to install when tilted

	V x 6PCS
	P x 1PC

STEP 12

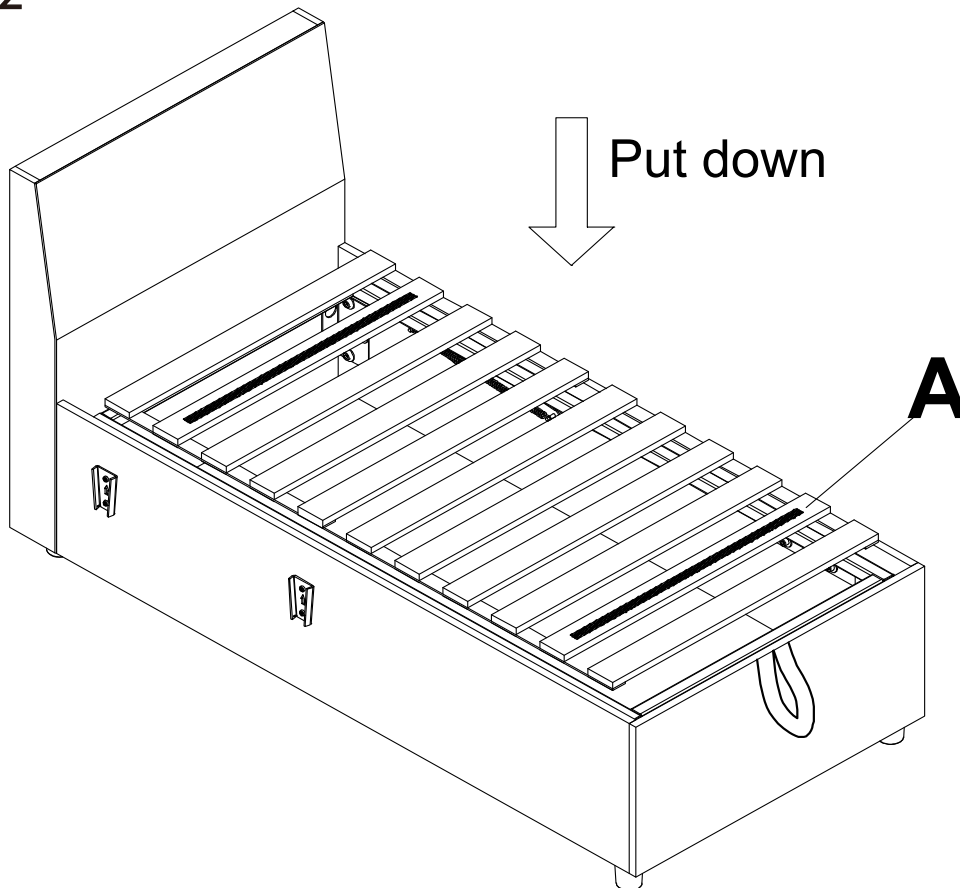

Main Structure Accessories

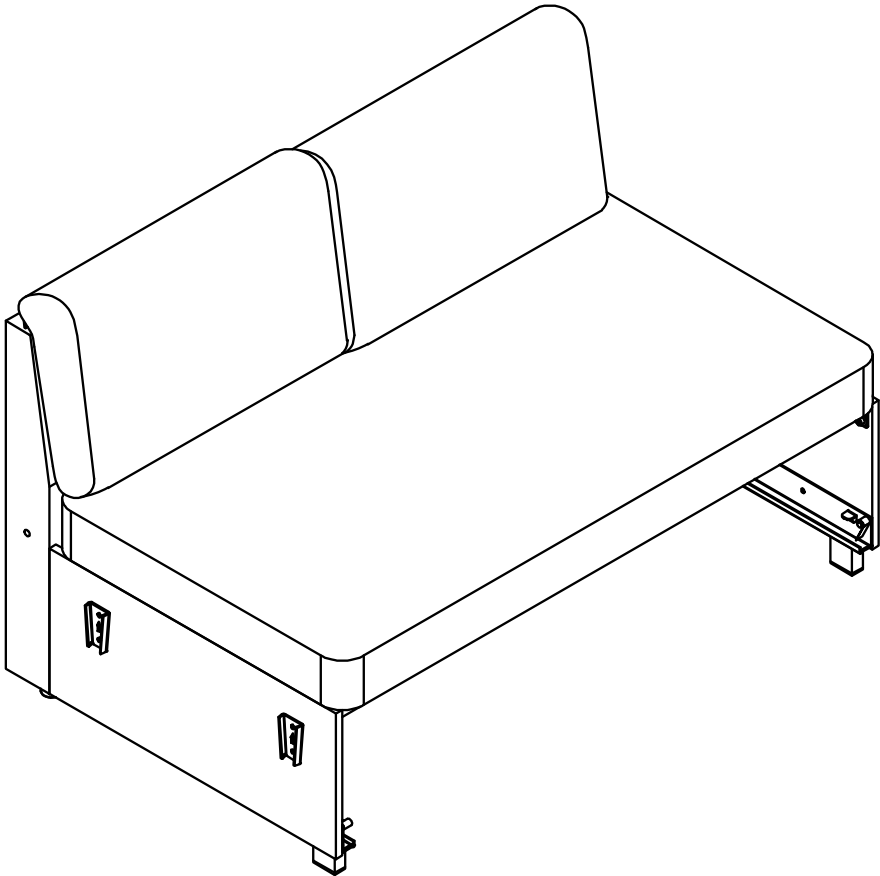
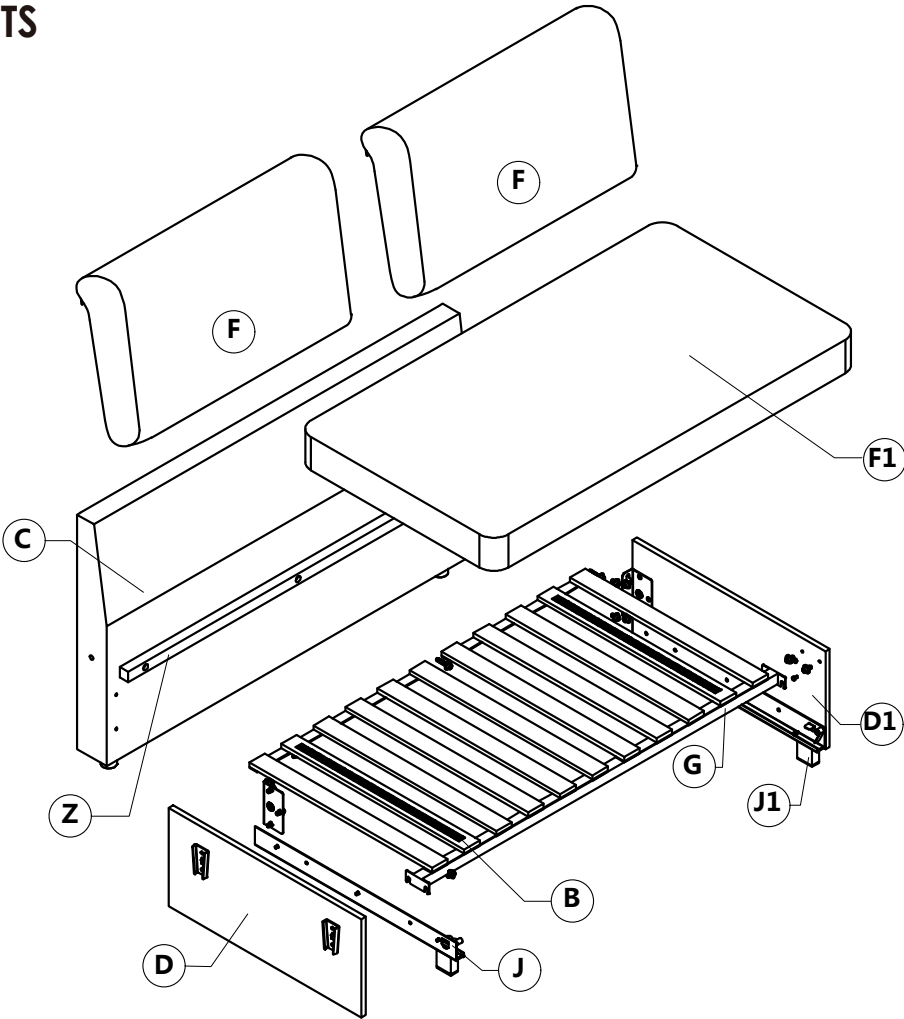

TWO SEATS

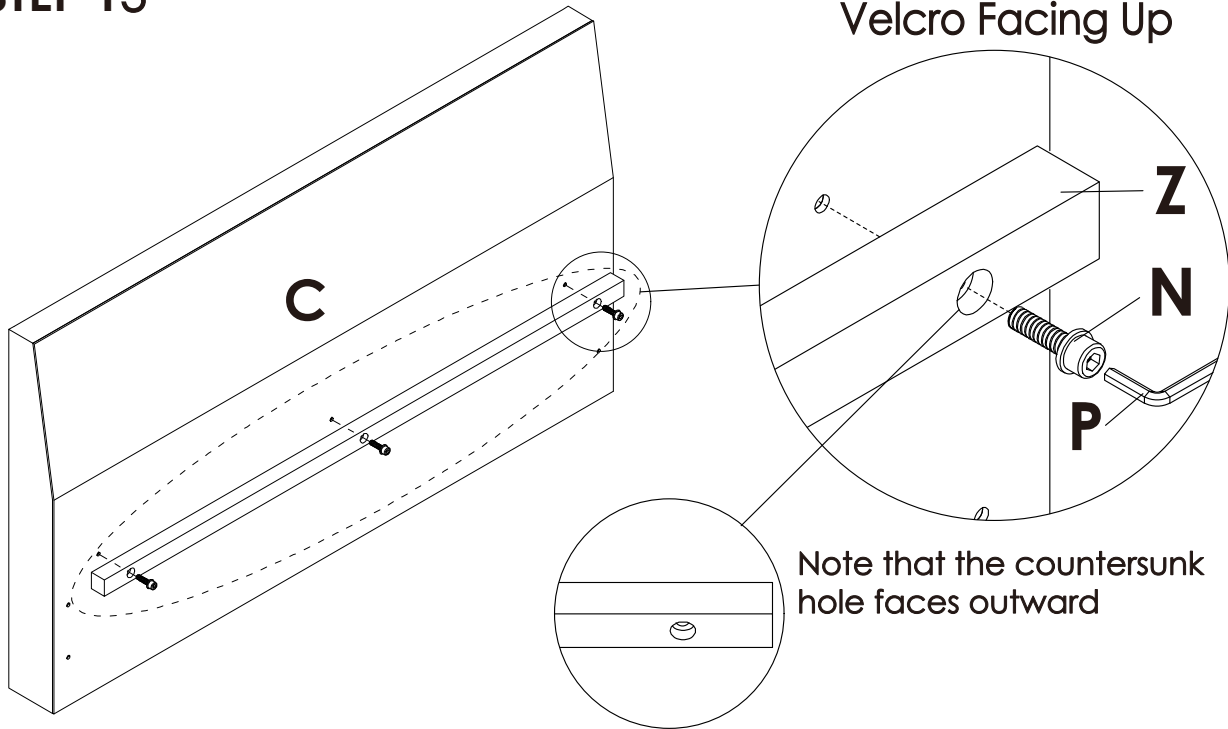

Assembly Steps(EN) / Montageschritte(DE)

STEP 13



	N x 3PCS
	P x 1PC

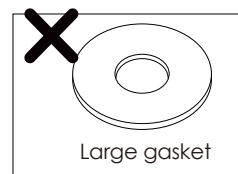

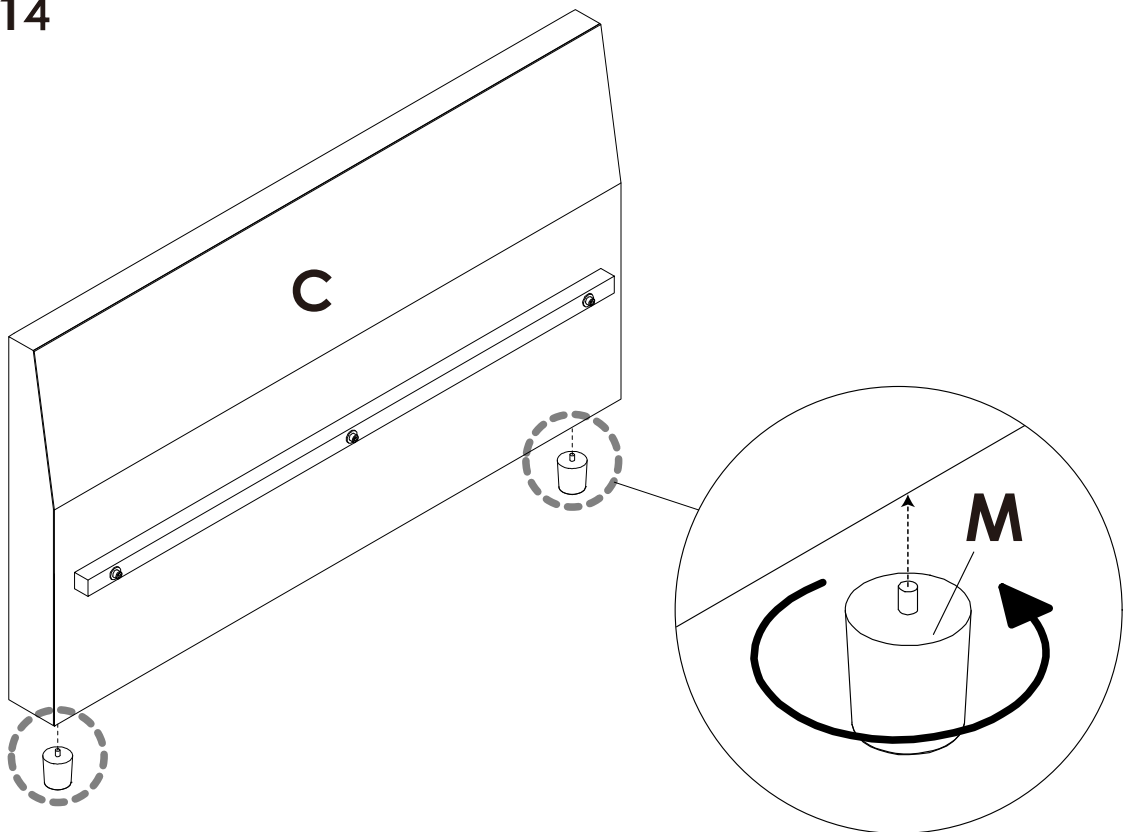

STEP 14

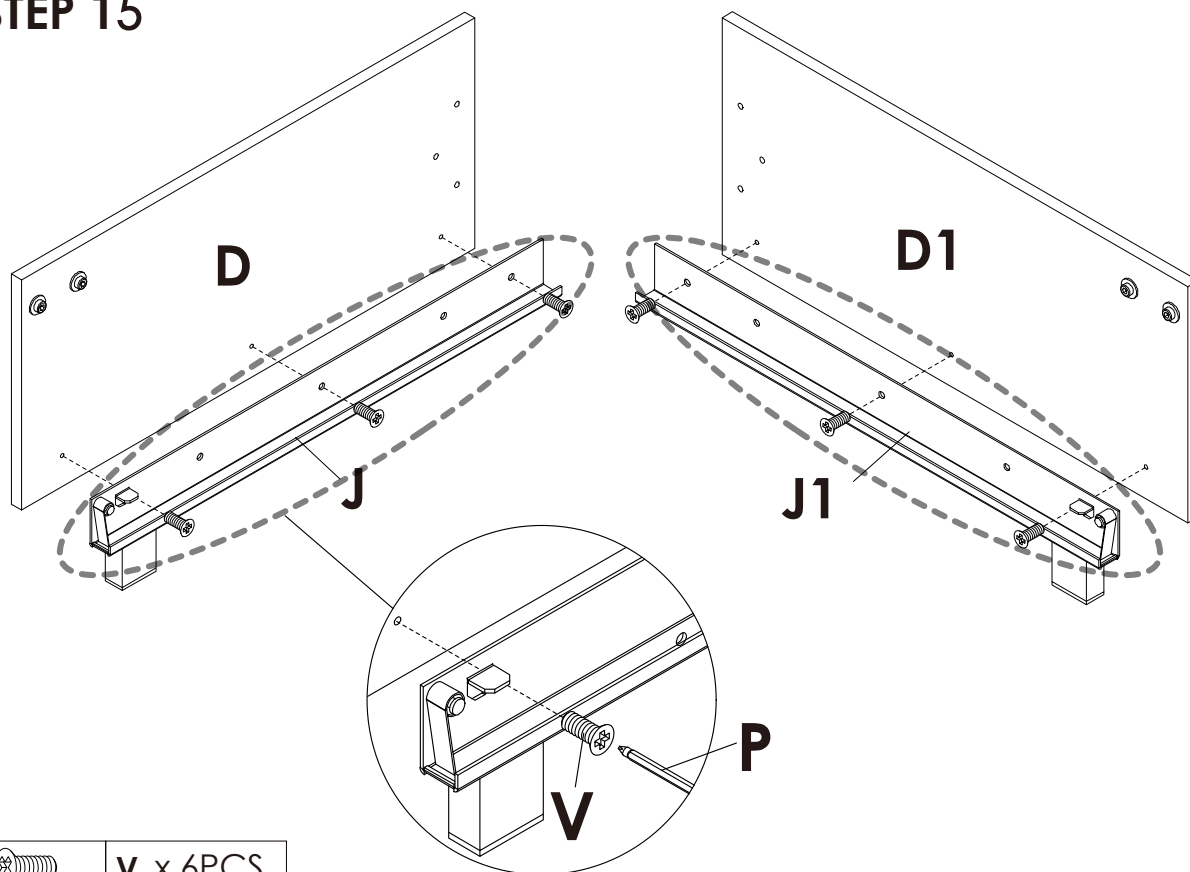

Assembly Steps(EN) / Montageschritte(DE)

STEP 15





	V x 6PCS
	P x 1PC

STEP 16

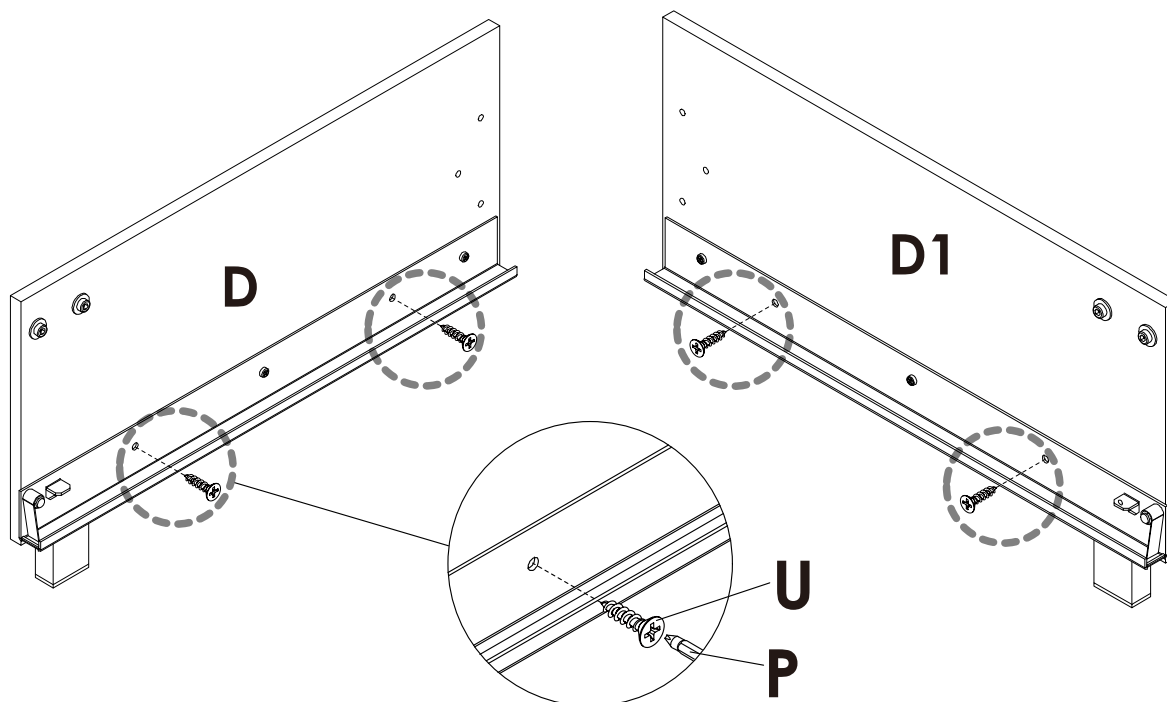
Reinforcing lock with self-tapping screws







	U x 4PCS
	P x 1PC

Tips: Self-tapping screw is an auxiliary reinforcement function, you can choose to reinforce or not.

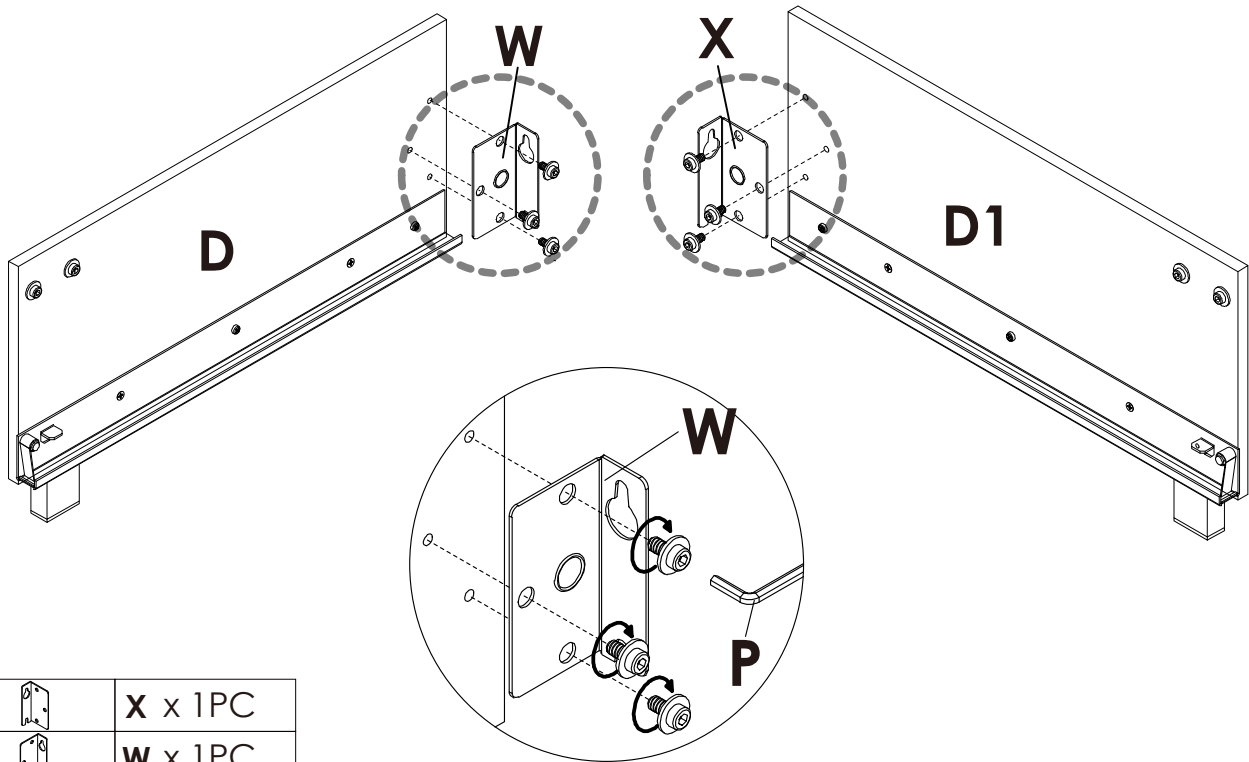
Assembly Steps(EN) / Montageschritte(DE)

STEP 17 First, loosen the screws properly for a better fit.



	X x 1PC
	W x 1PC
	P x 1PC

STEP 18 First loosen the screws, install the mounting plate, and then lock the screws.

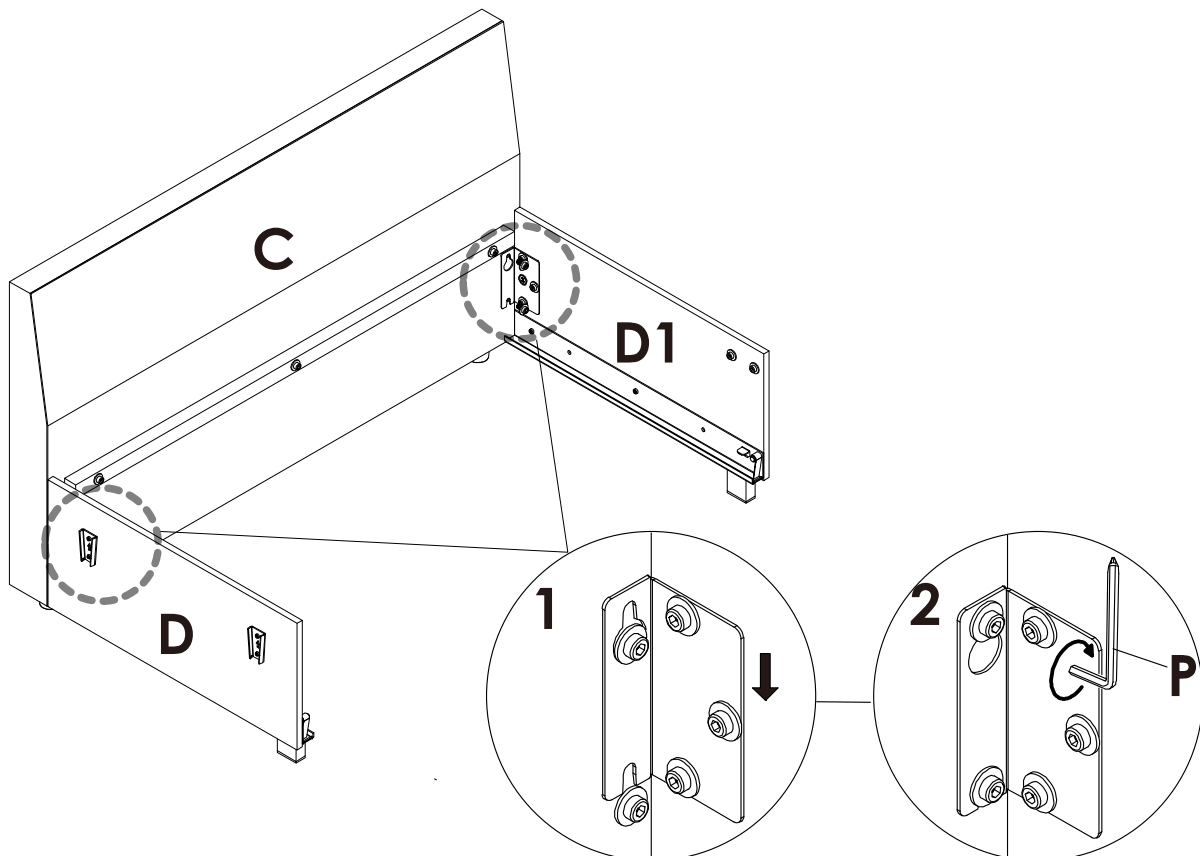

	P x 1PC
---	---------

Assembly Steps(EN) / Montageschritte(DE)

STEP 19

First, loosen the screws properly for a better fit.

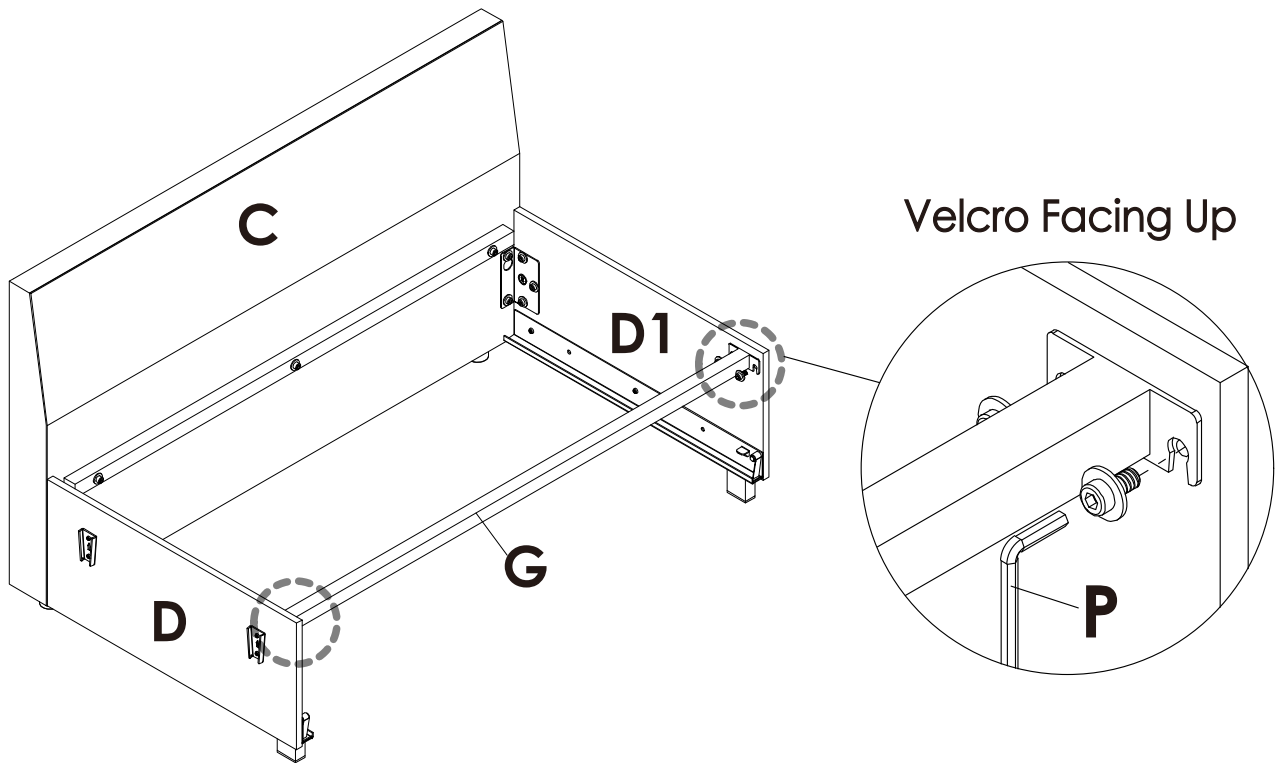

P x 1PC

STEP 20

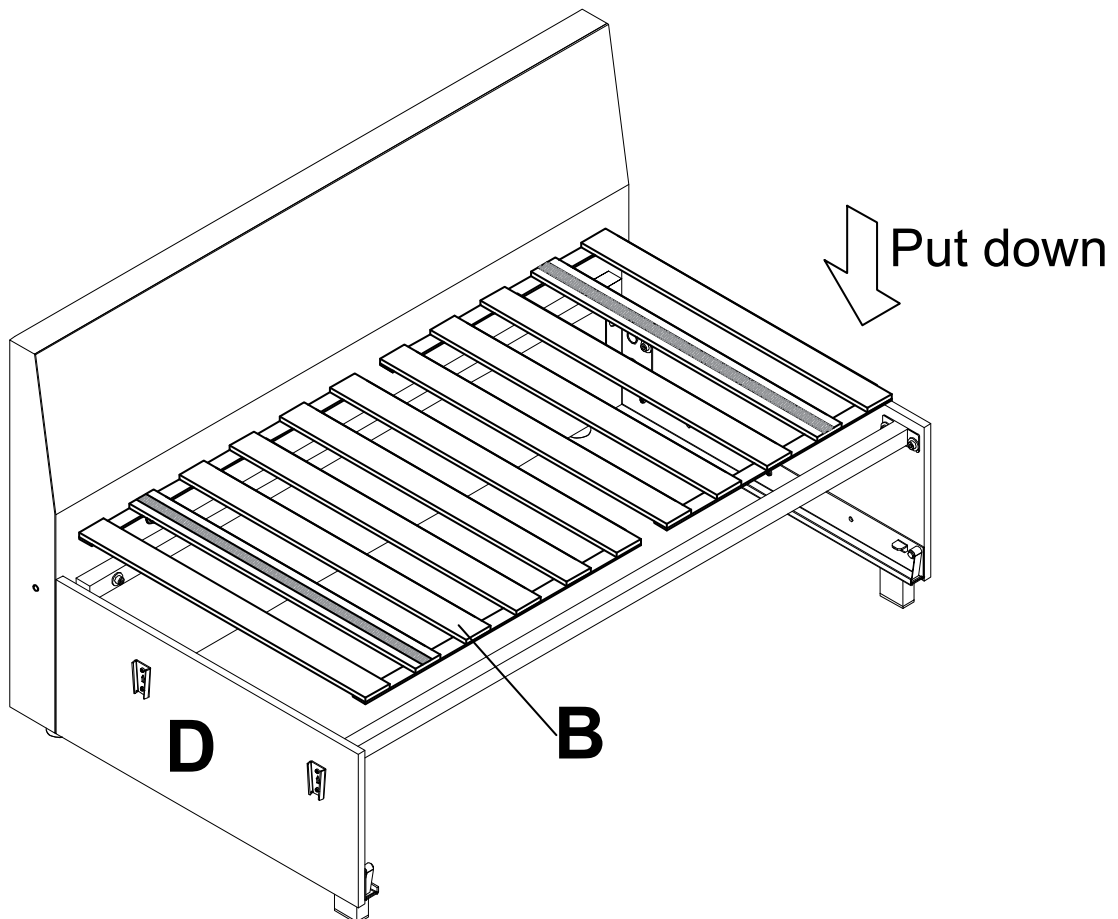

Main Structure Accessories

PULL-OUT

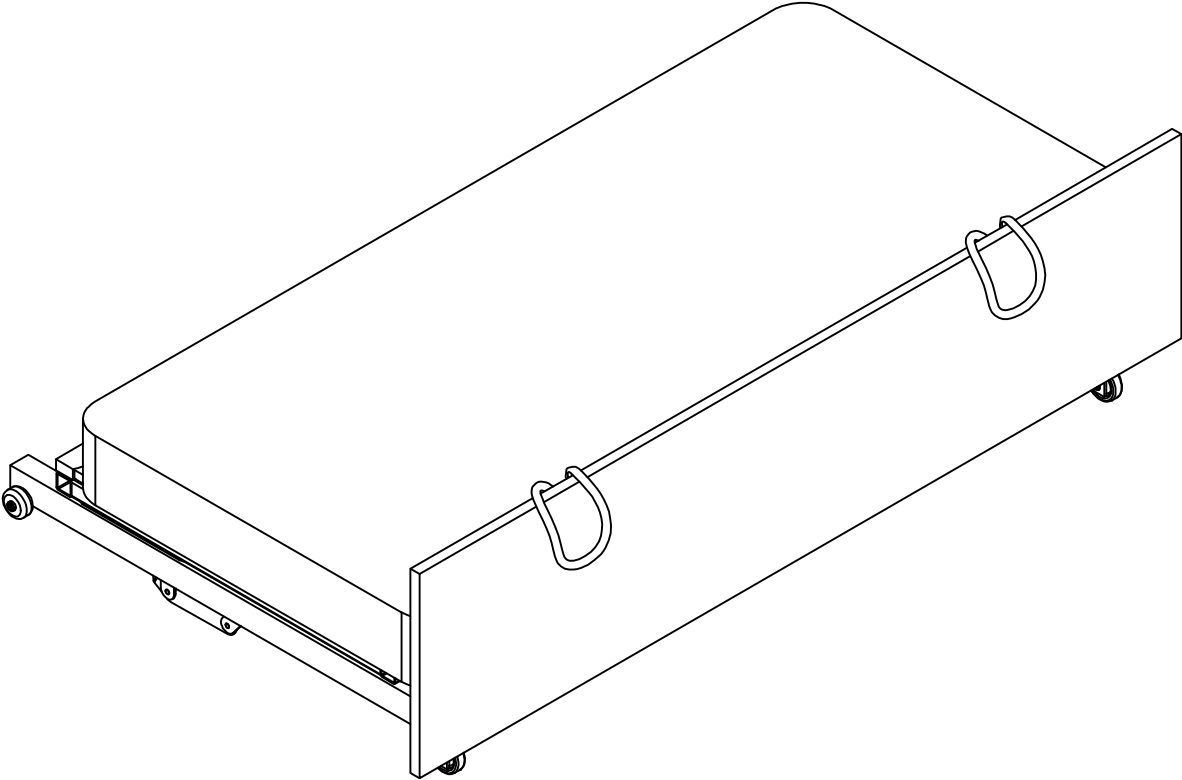
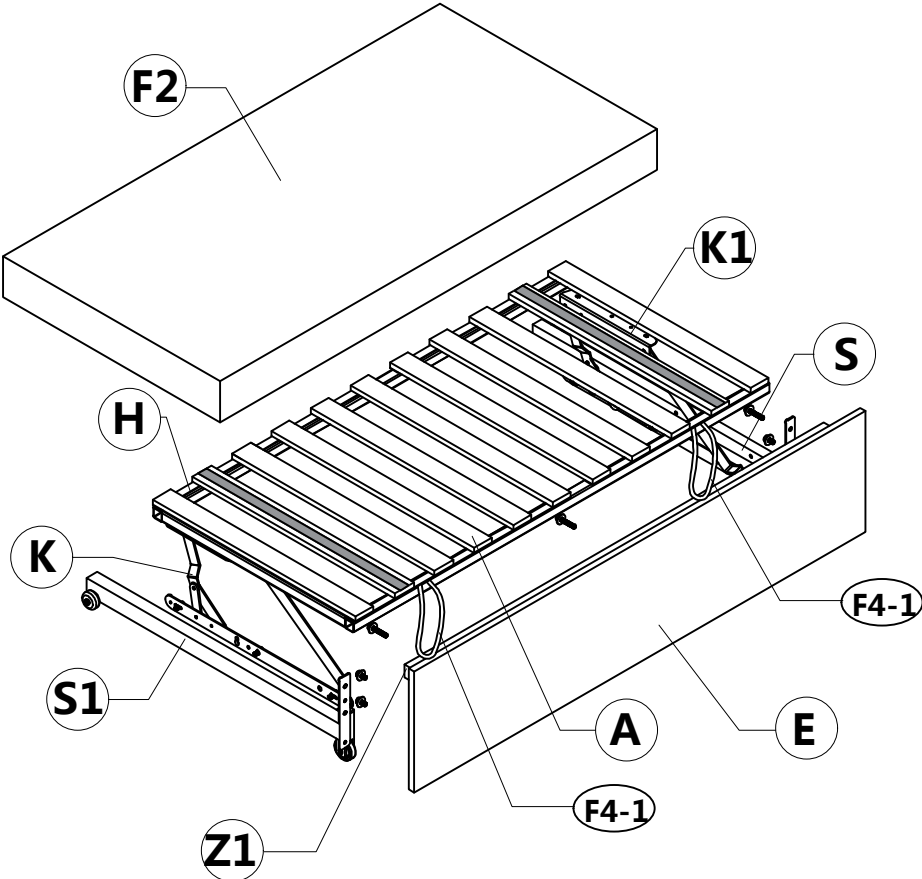

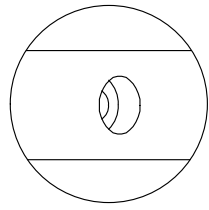

Assembly Steps(EN) / Montageschritte(DE)

STEP 21

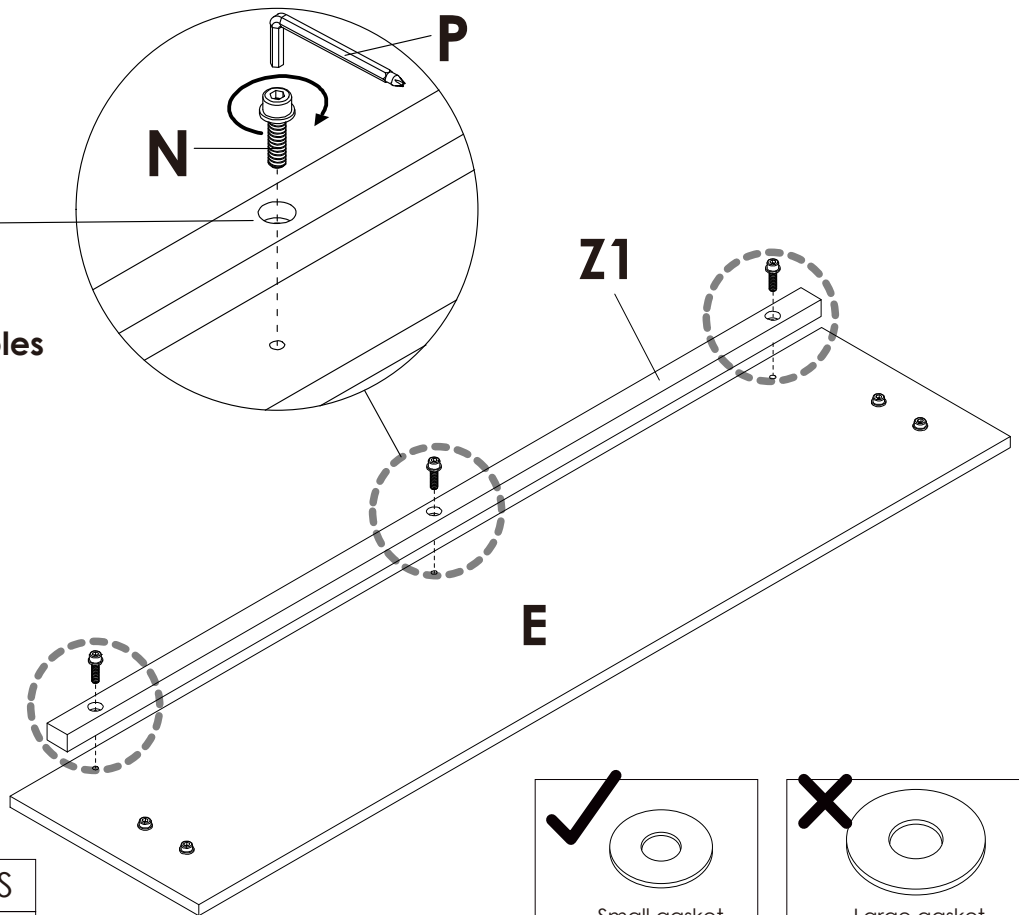

Countersunk holes
face outward.



	N x 3PCS
	P x 1PC

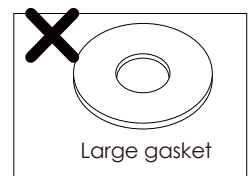

STEP 22

First, loosen the screws properly for a better fit.

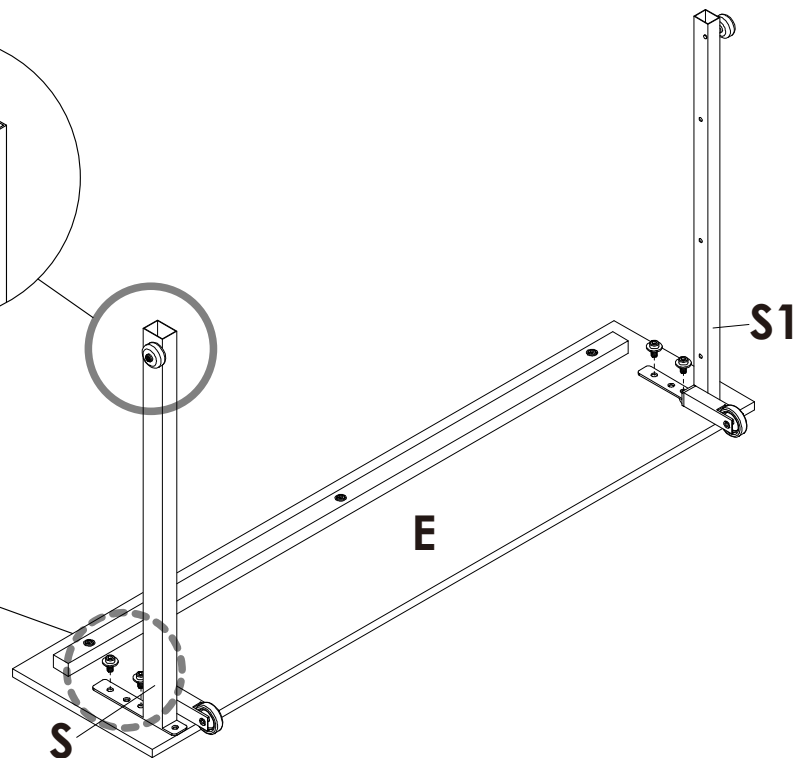
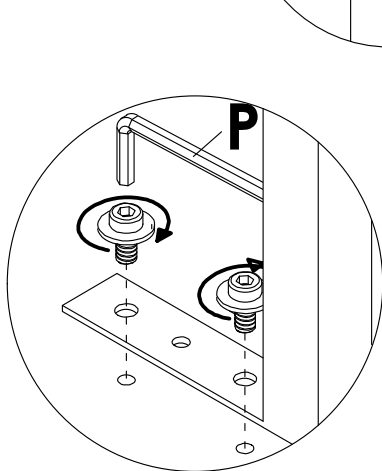
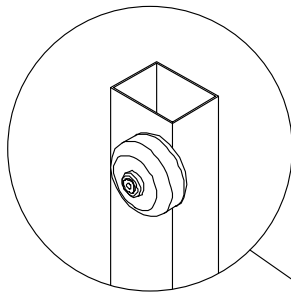



	P x 1PC
---	----------------

Assembly Steps(EN) / Montageschritte(DE)

STEP 23

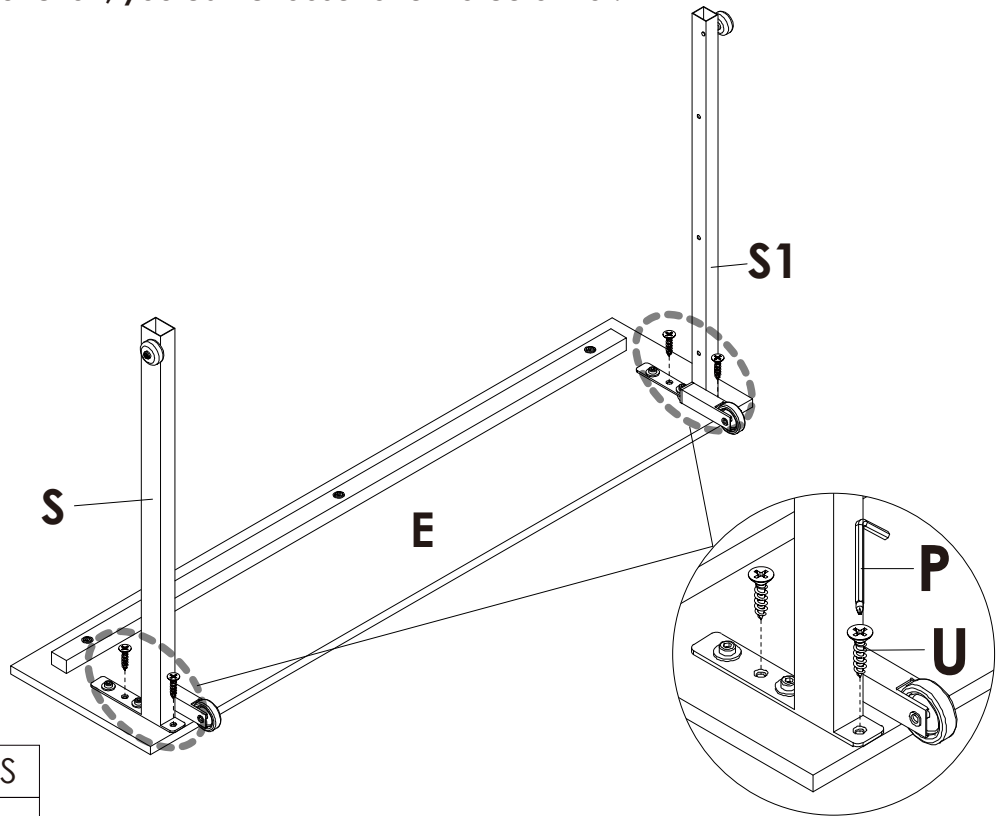

Tips: Self-tapping screw is an auxiliary reinforcement function, you can choose to reinforce or not.

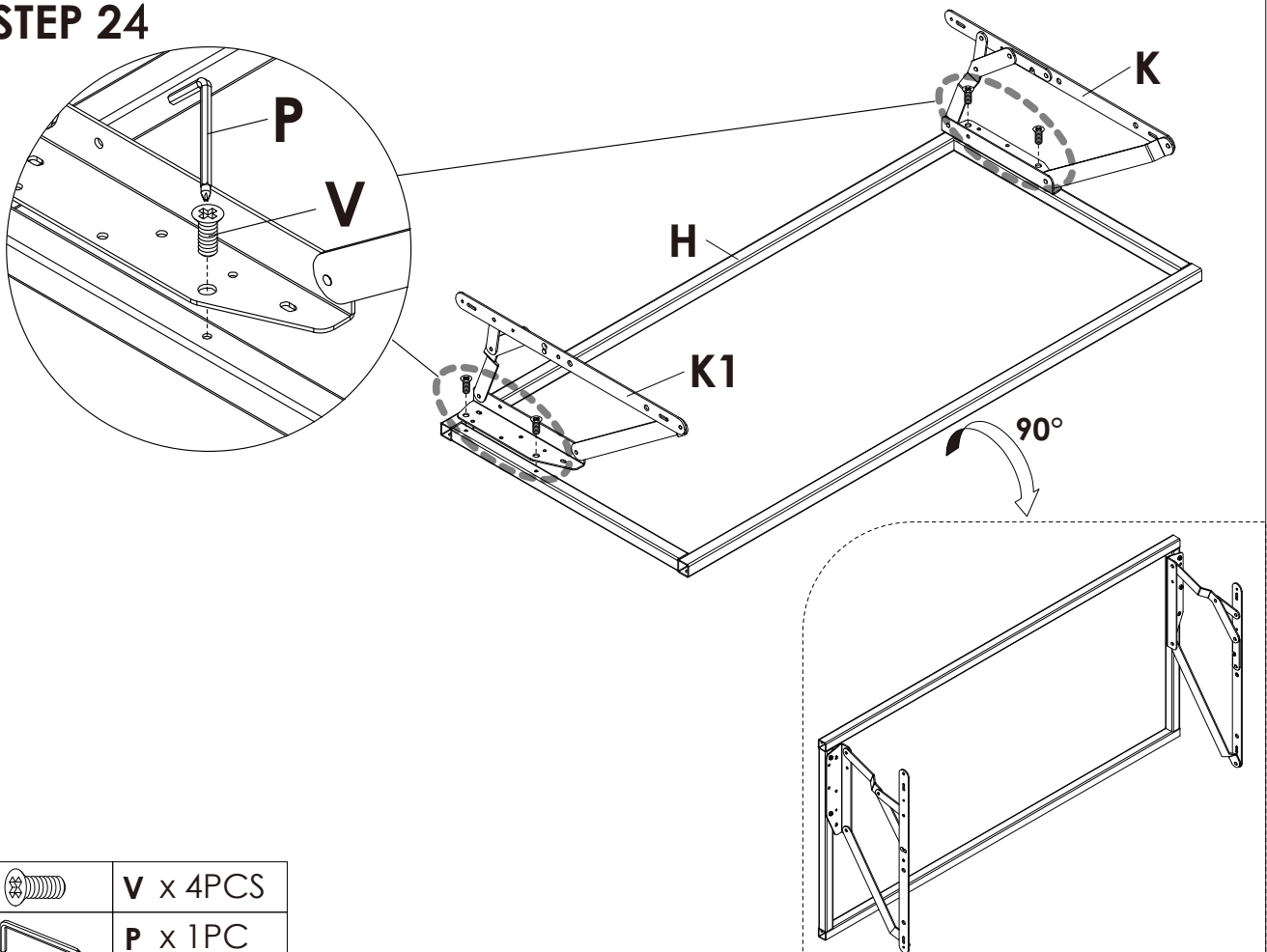

	U x 4PCS
	P x 1PC

STEP 24





	V x 4PCS
	P x 1PC

Assembly Steps(EN) / Montageschritte(DE)

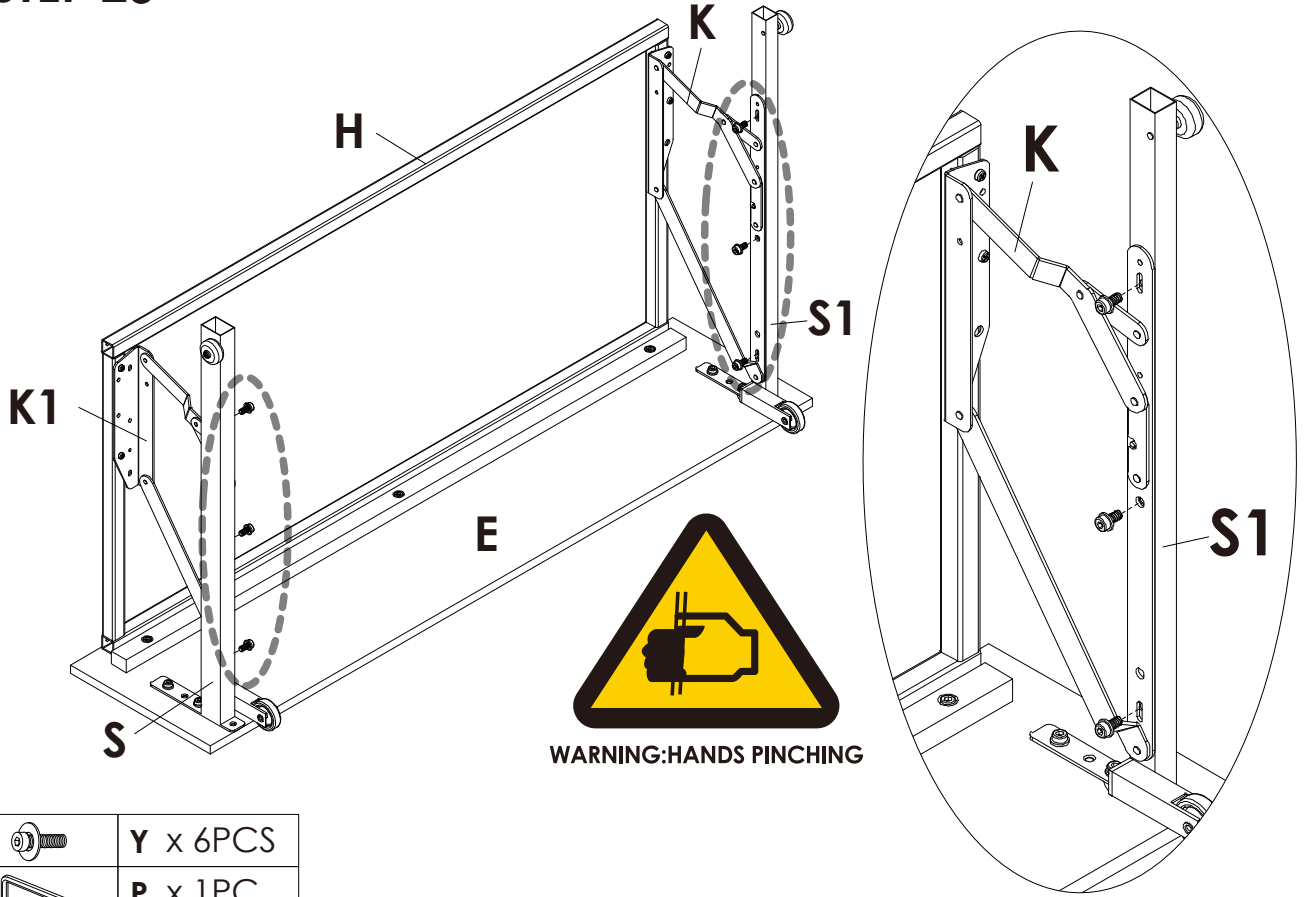
STEP 25



	Y x 6PCS
	P x 1PC

STEP 26

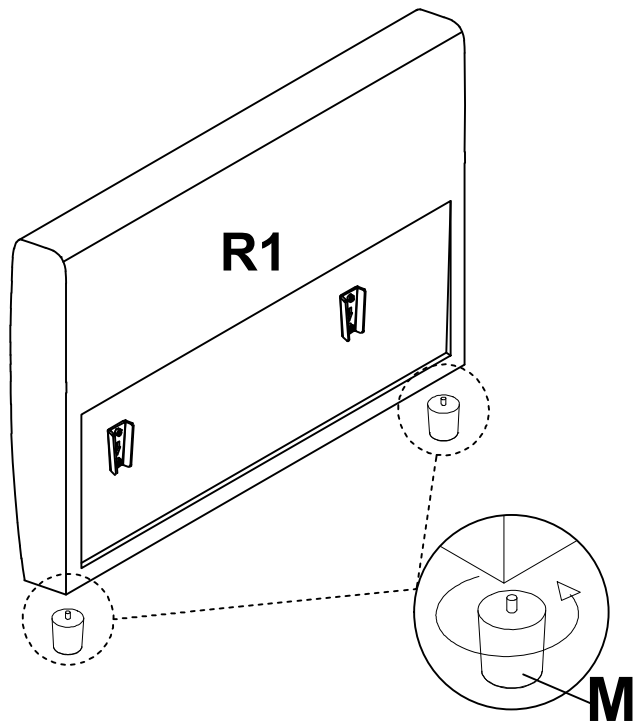

Assembly Steps(EN) / Montageschritte(DE)

STEP 27

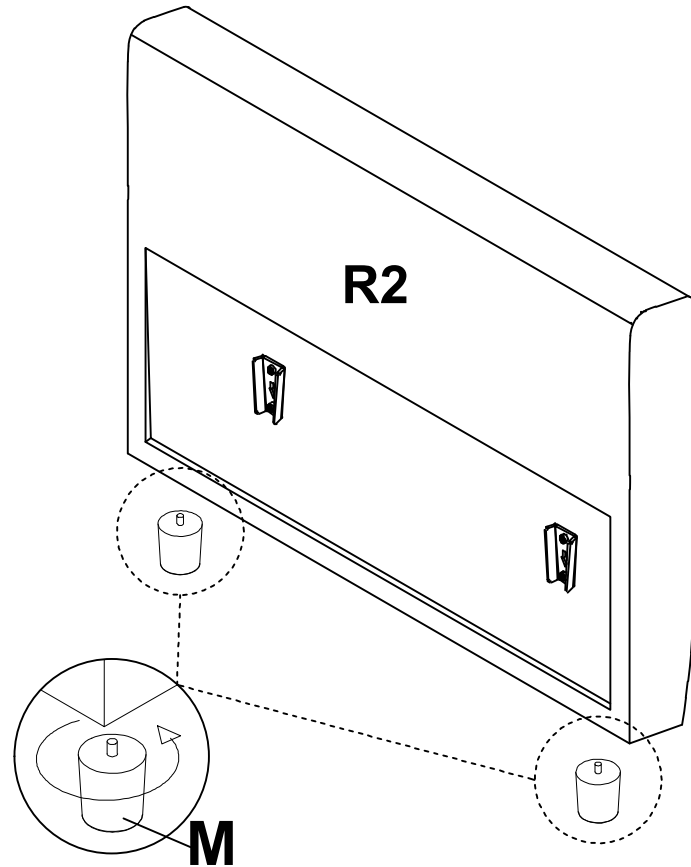

Assembly Option ① STEP 28

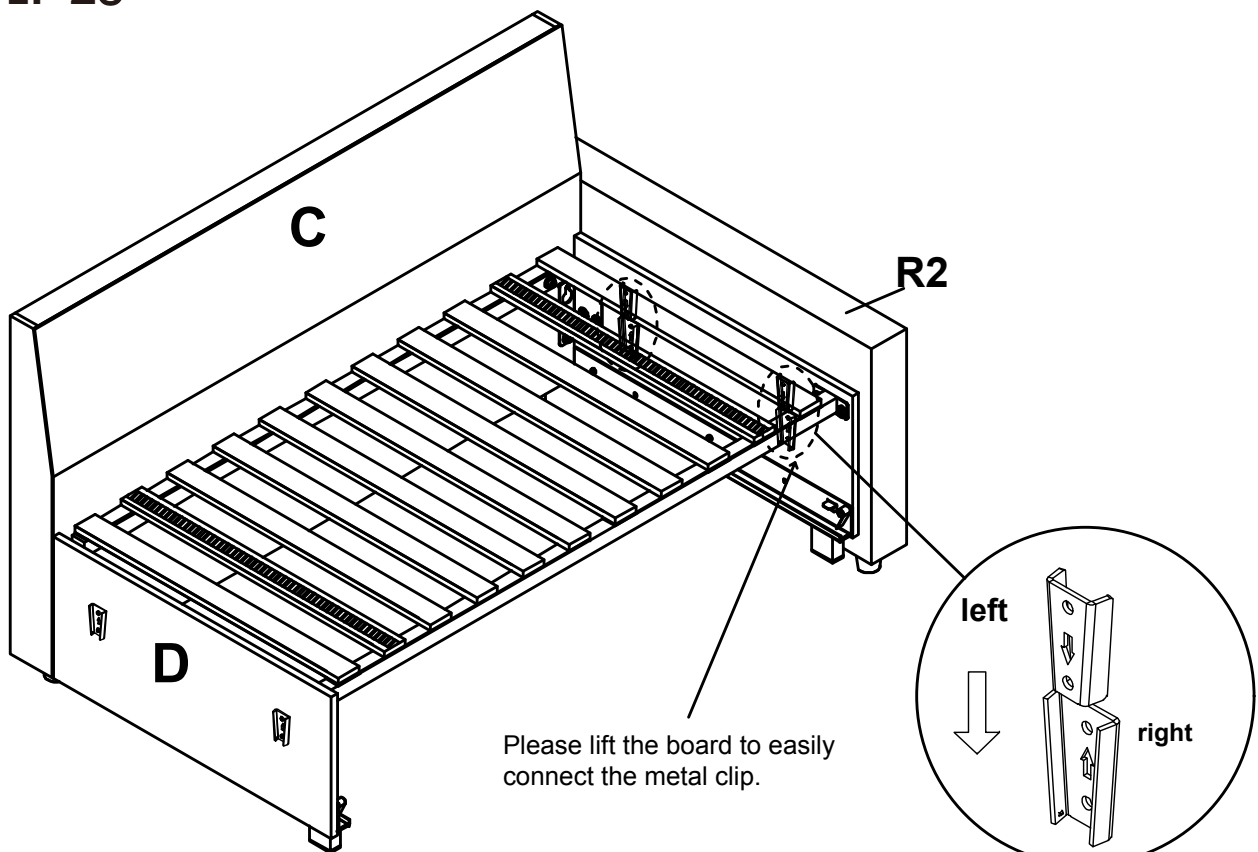

Assembly Steps(EN) / Montageschritte(DE)

Assembly Option ① STEP 29

Please lift the board to easily connect the metal clip.

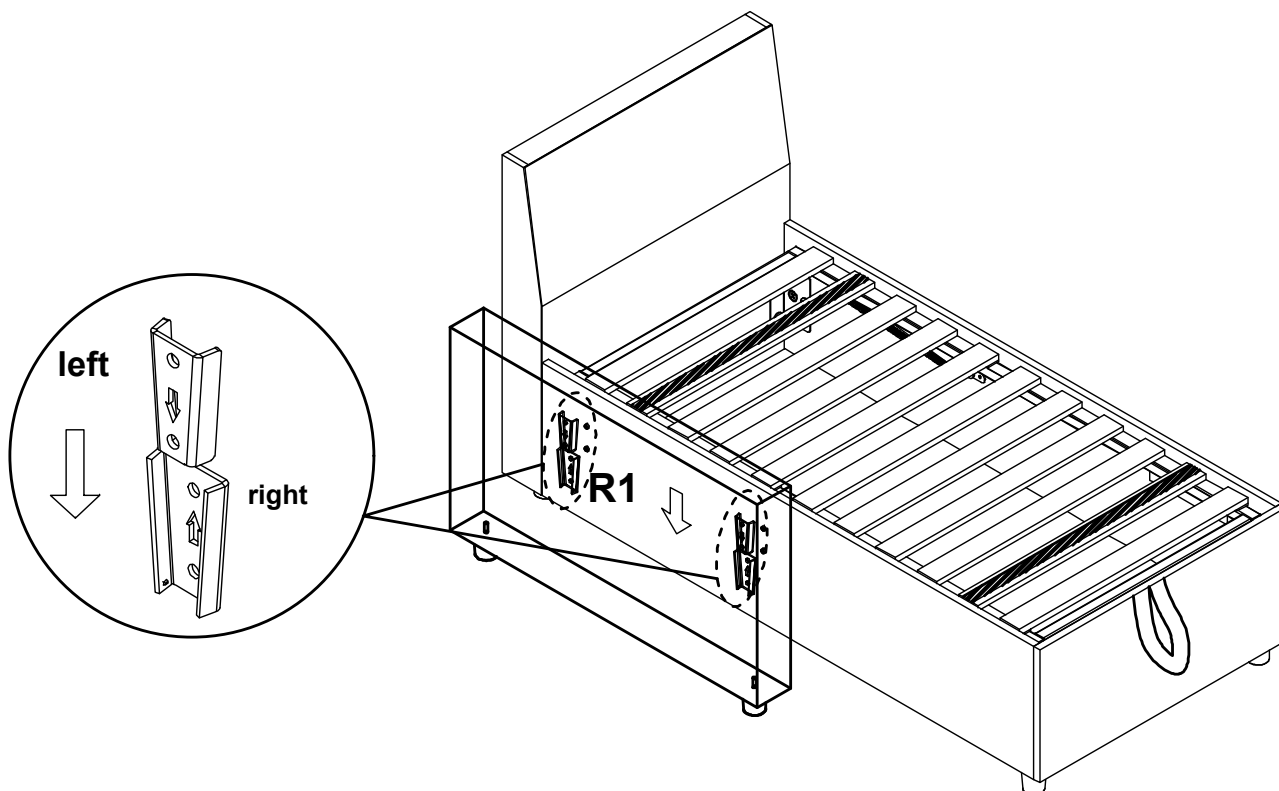

Assembly Option ① STEP 30

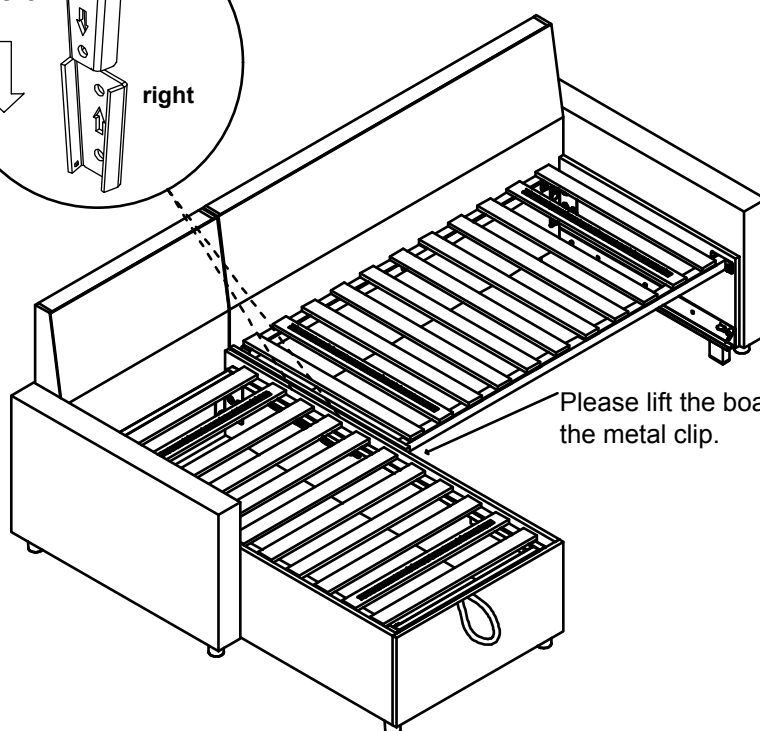
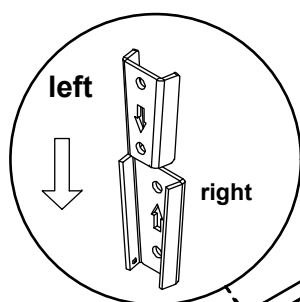

Please lift the board to easily connect the metal clip.

Assembly Steps(EN) / Montageschritte(DE)

Assembly Option ①

STEP 31

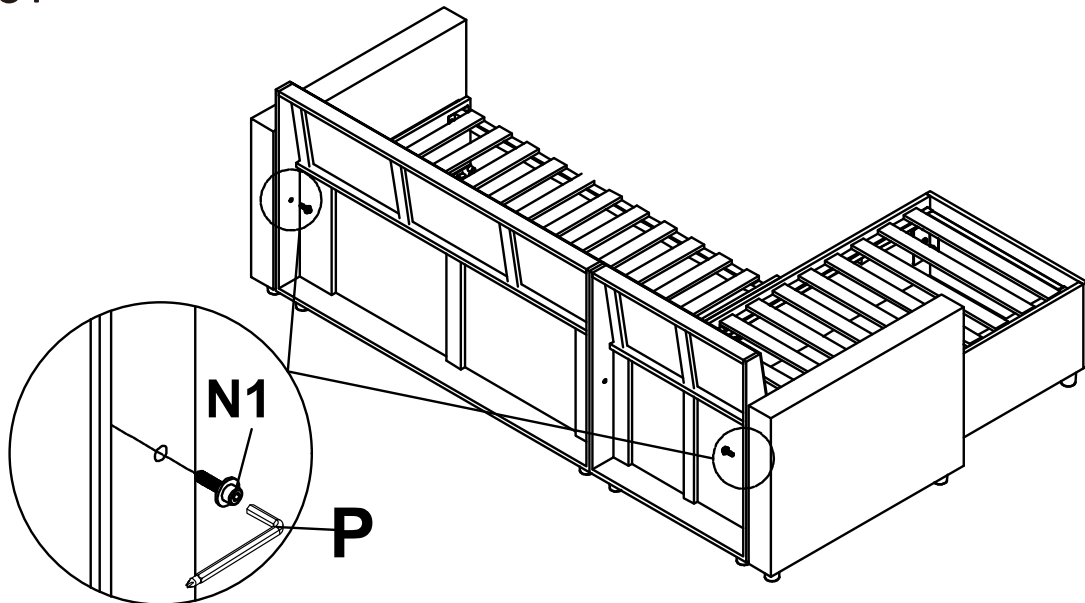

Secure with locking screws

	N1 x 2PCS
	P x 1PC

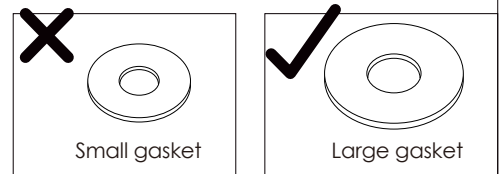

Assembly Option ①

STEP 32

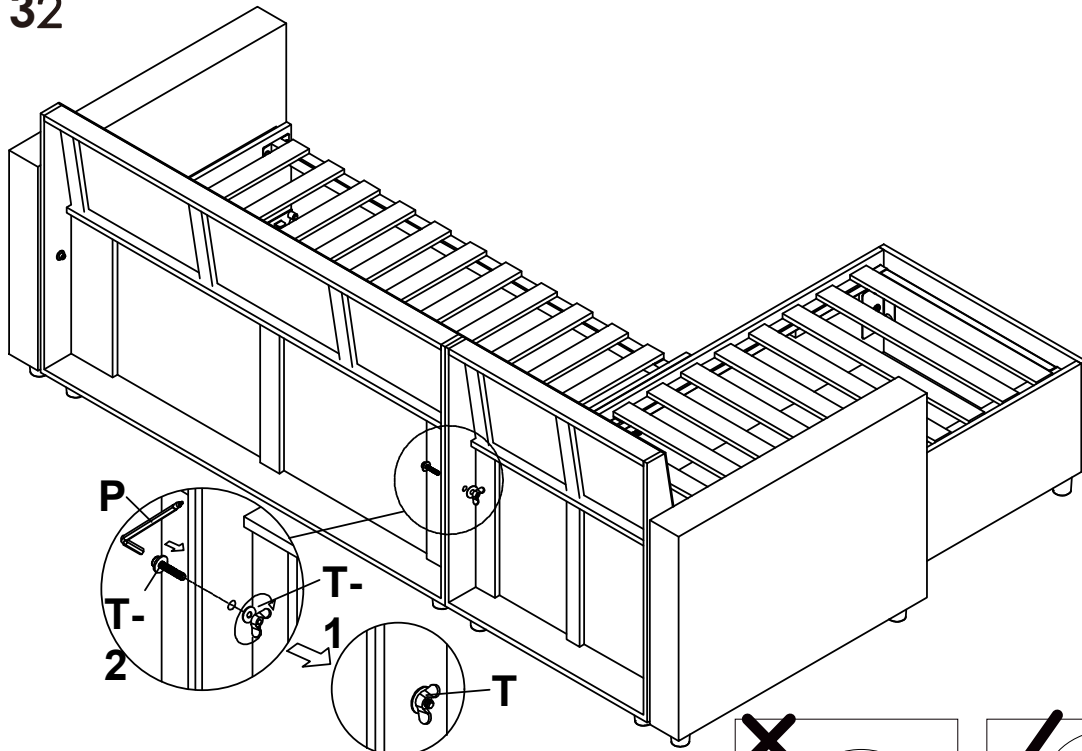

Screw through hole and tighten with butterfly nut.

	P x 1PC
	T x 1PC

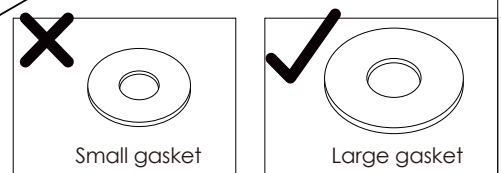

Assembly Steps(EN) / Montageschritte(DE)

Assembly Option ①

STEP 33

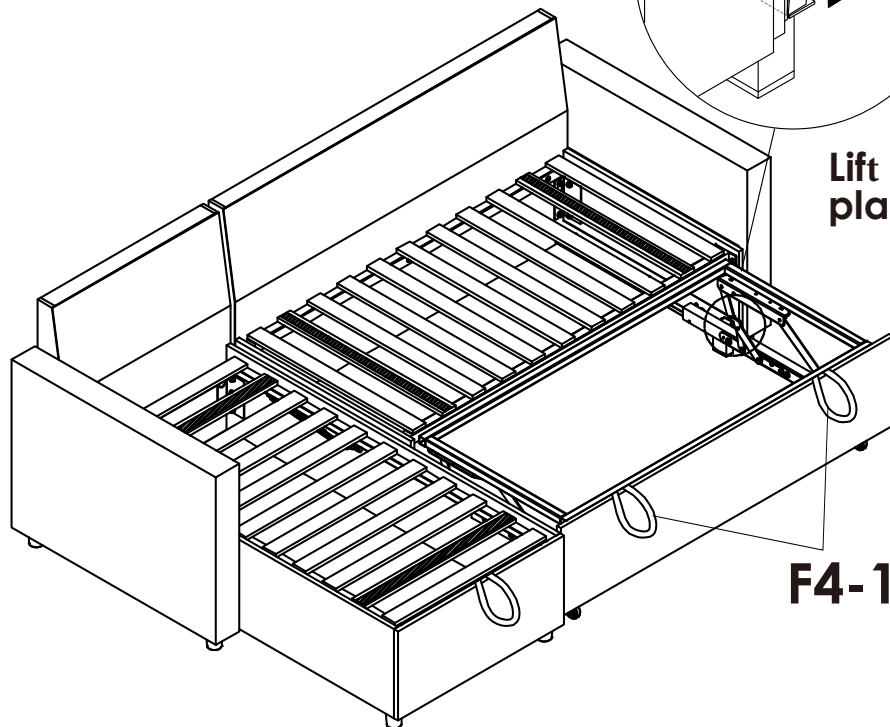

Assembly Option ①

STEP 34

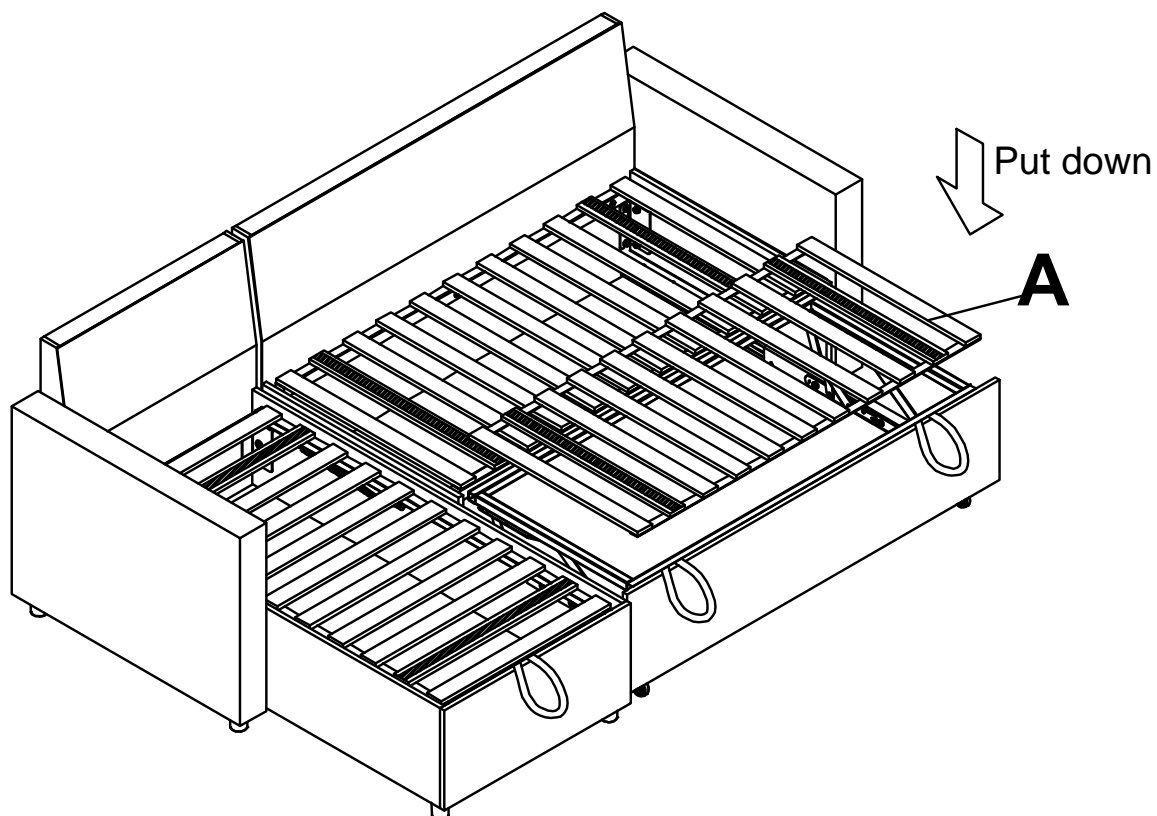

Assembly Option ①

STEP 35

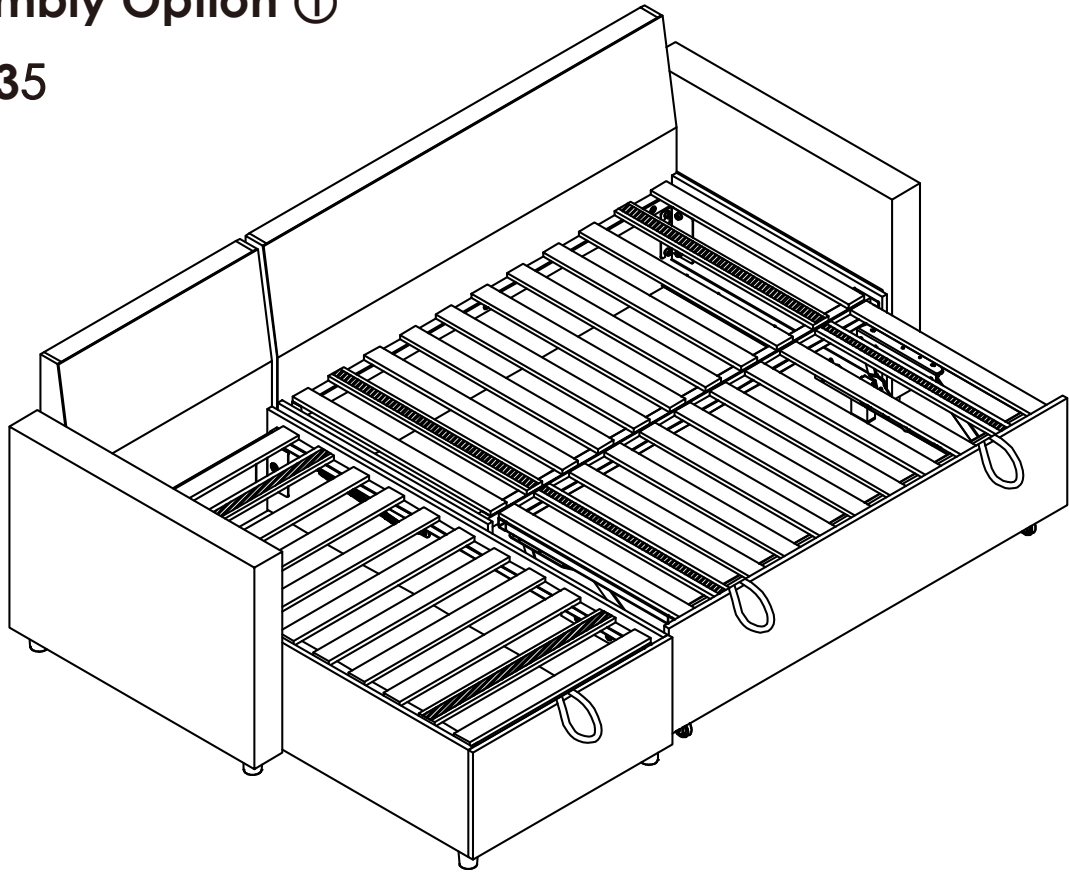

Assembly Option ①

STEP 36

Insert the zipper head and tighten the zipper

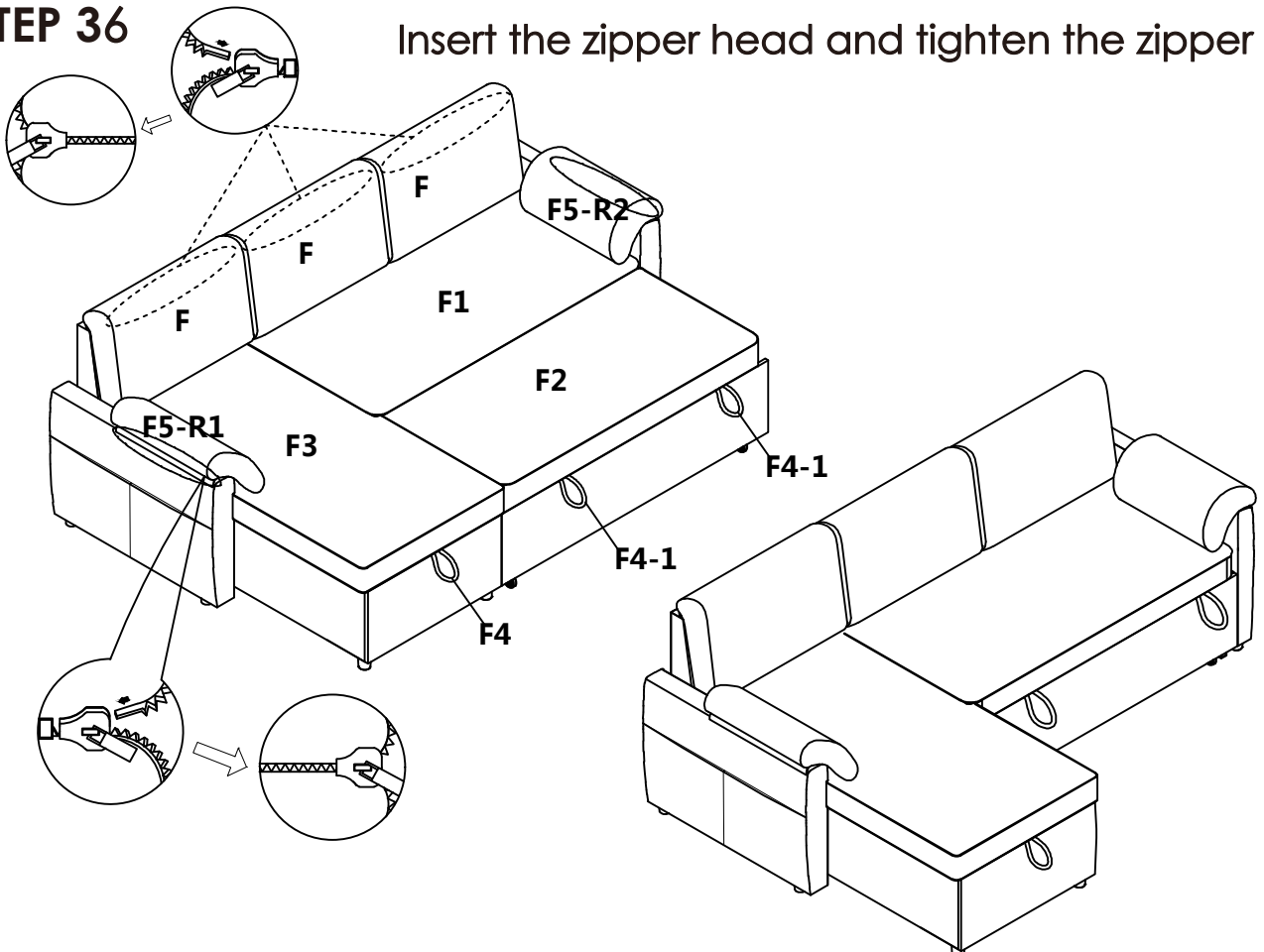

Assembly Steps(EN) / Montageschritte(DE)

Assembly Option ② STEP 28

Please lift the board to easily connect the metal clip.

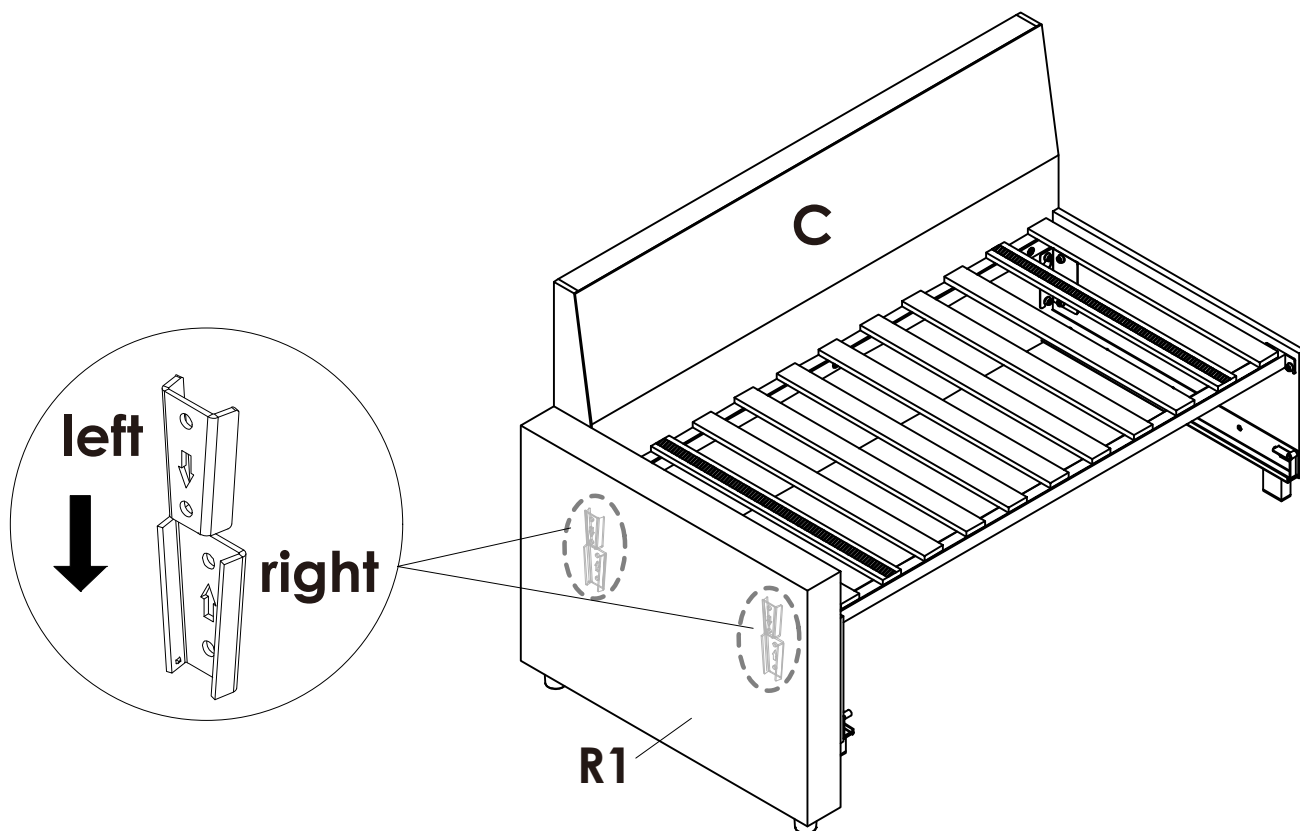

Assembly Option ② STEP 29

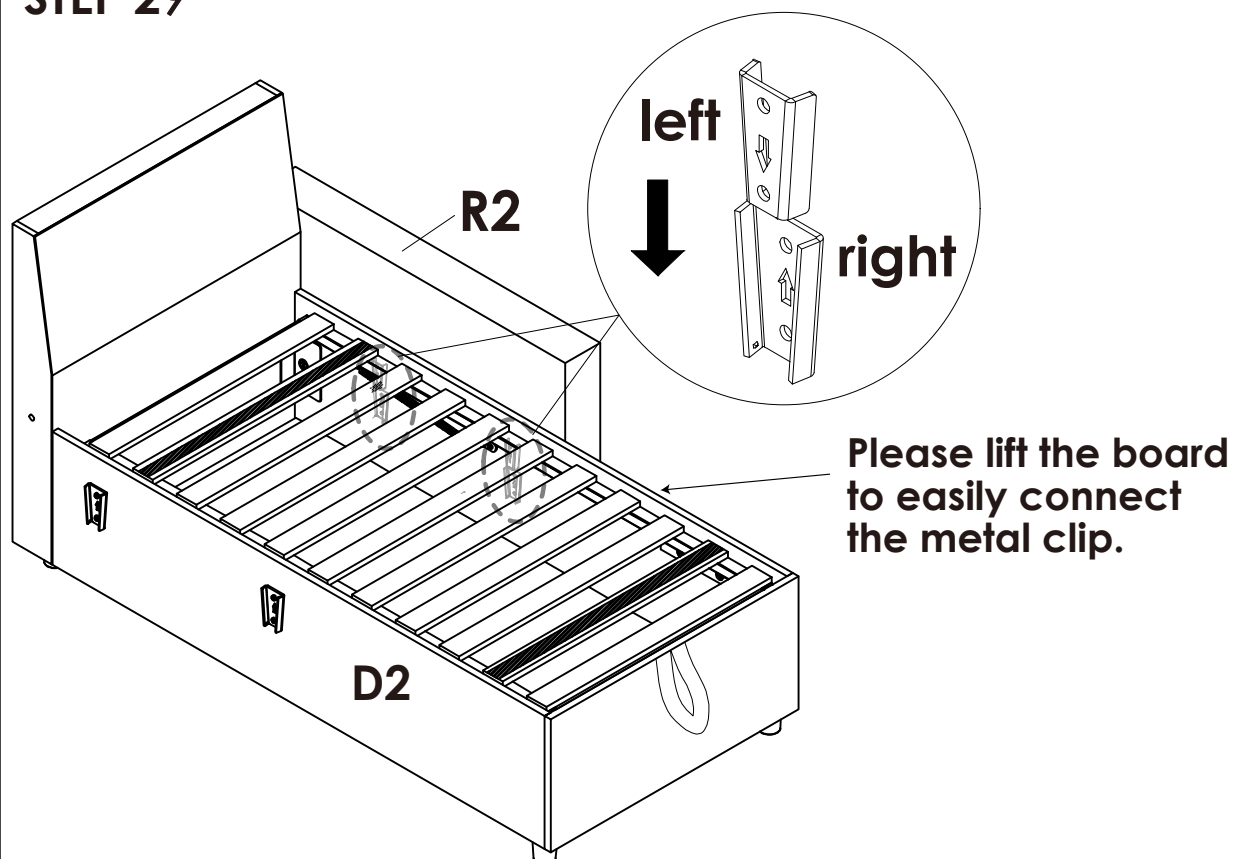

Assembly Steps(EN) / Montageschritte(DE)

Assembly Option ②

STEP 30

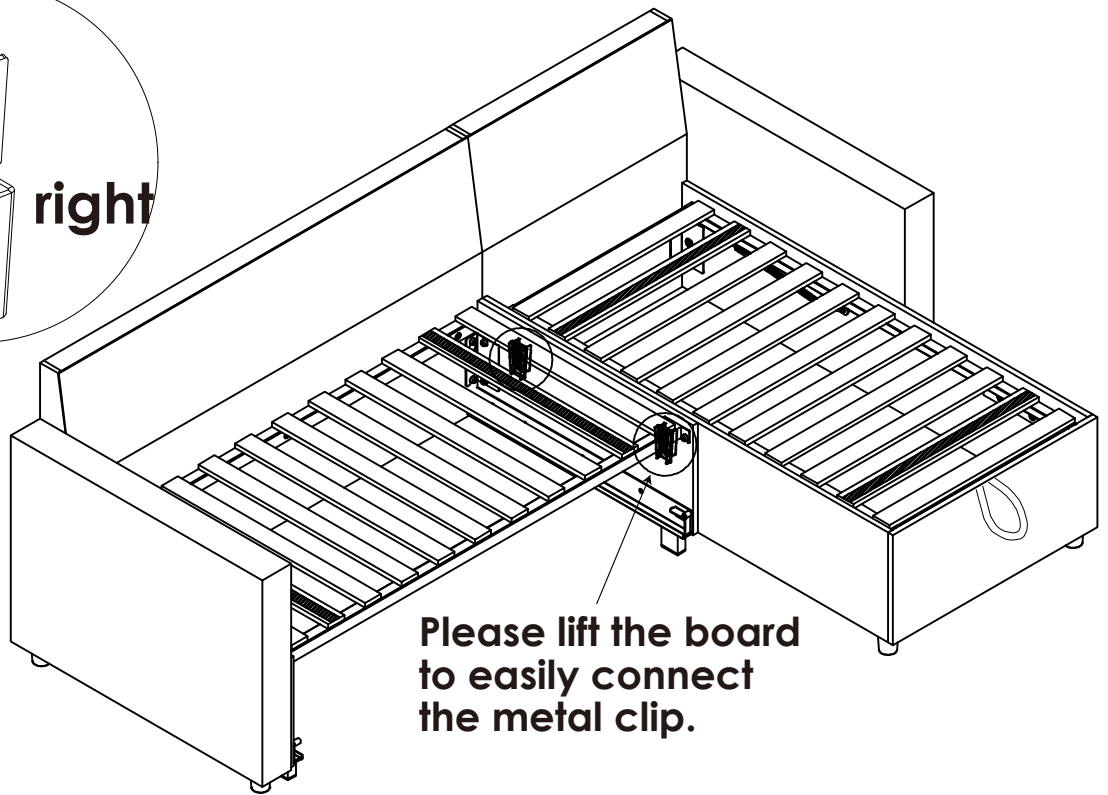
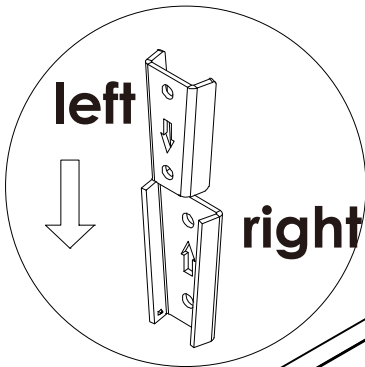

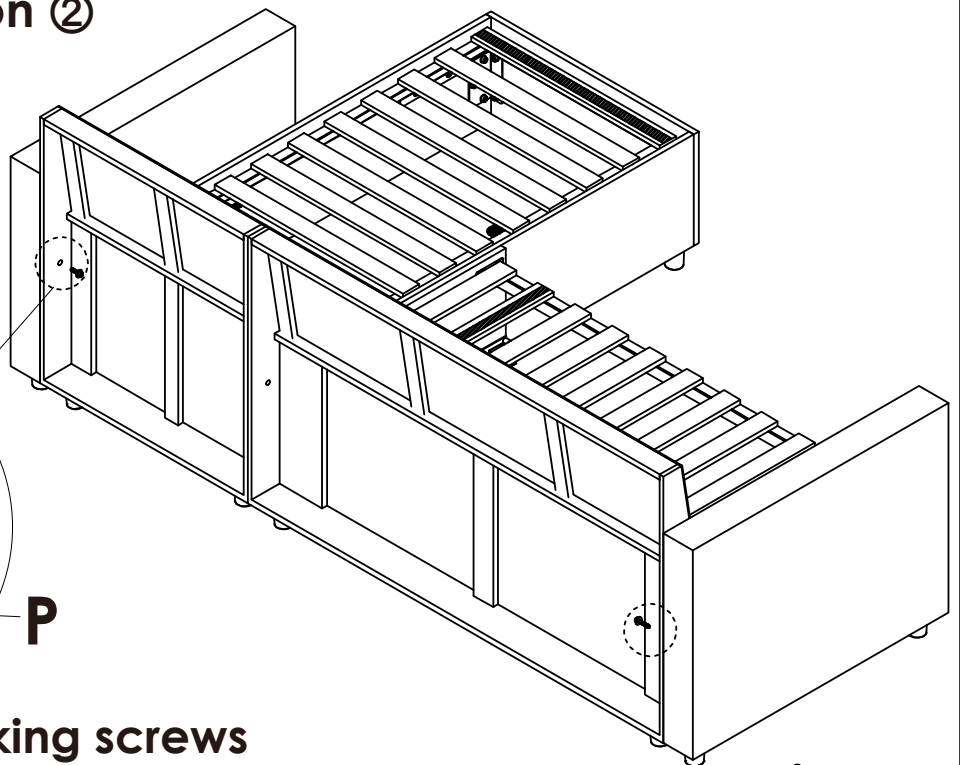
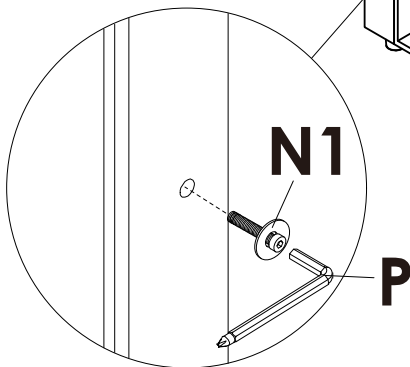

Assembly Option ②

STEP 31



Secure with locking screws

	N1 x 2PCS
	P x 1PC

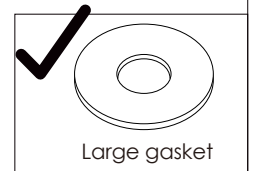
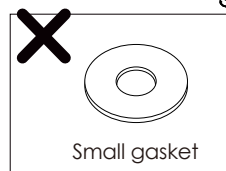



Assembly Steps(EN) / Montageschritte(DE)

Assembly Option ②

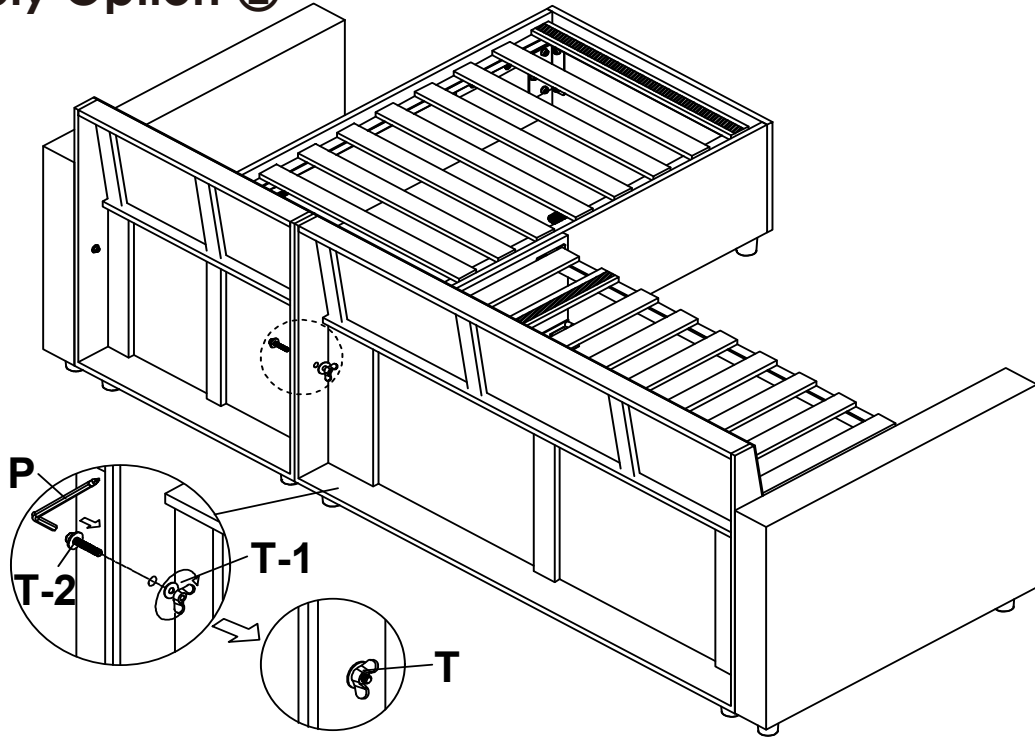
STEP 32



Screw through hole and tighten with butterfly nut.

	P x 1PC
	T x 1PC

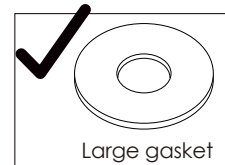
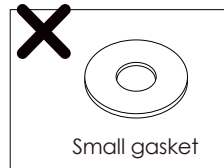

Assembly Option ②

STEP 33

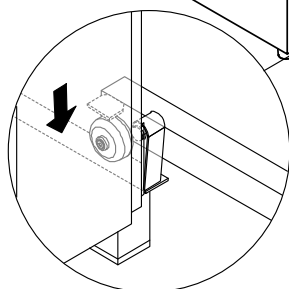
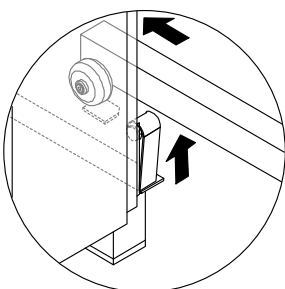
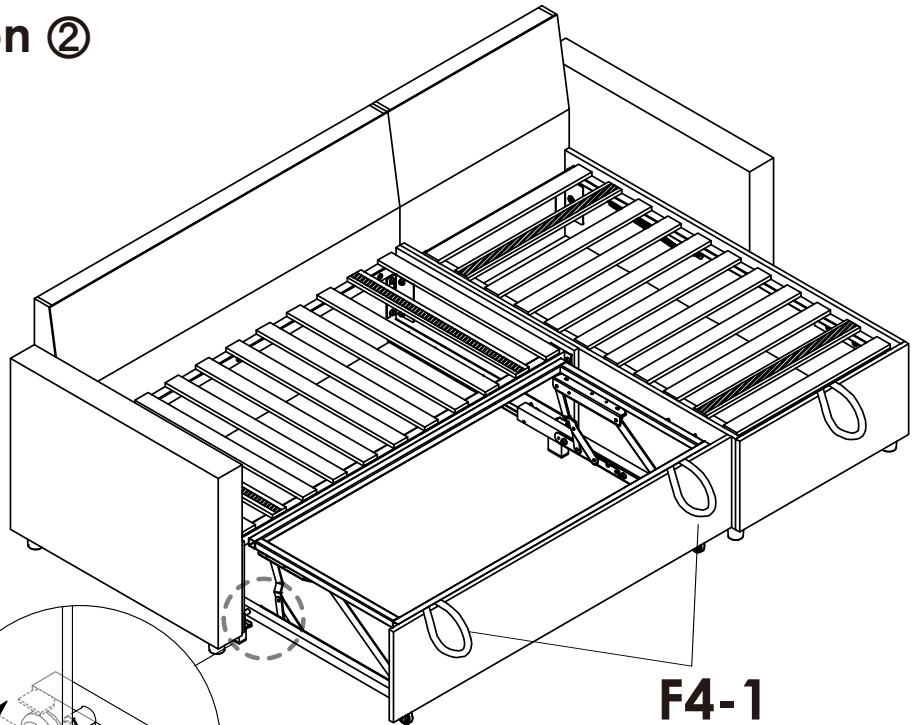

Lift it slightly and place it on the track.

Assembly Option ②

STEP 34

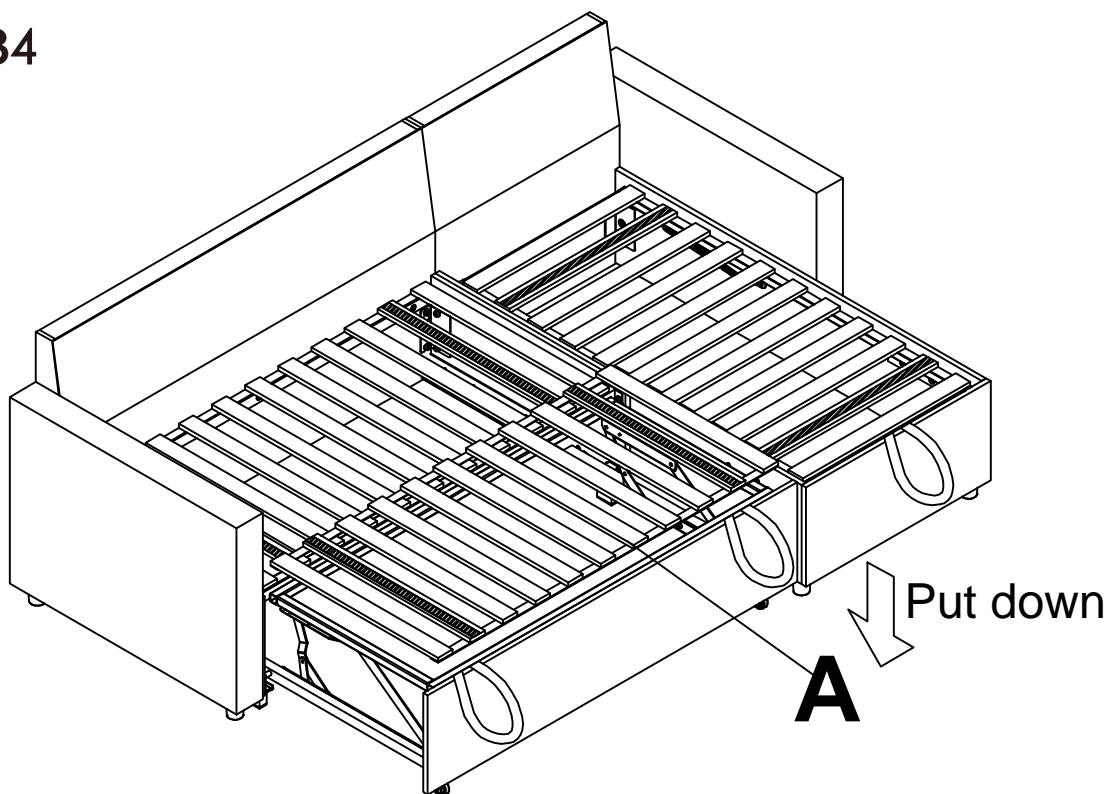

Assembly Option ②

STEP 35

Insert the zipper head and tighten the zipper

