

CARE AND MAINTENANCE

Store outdoor furniture indoors or cover well when not in use.

Remove wooden furniture from standing water. Dust regularly with small brush or vacuum

Spills should be taken care of immediately before they harden or stain with a slightly dampened sponge.

NOTICE

* Please make sure that you have all parts indicated before you begin assembly of this item

* This item should be assembled on a soft surface to prevent scratching the finish during assembly

* This item may require periodic tightening

Weight Capacity : 600 Ibs

Warning : Do not stand on chair

Warning : Do not over torque bolts / screws



Part List and Hardware List

PIECE	DESCRIPTION	PICTURE	QUANTITY
A	Frame back 1		1X
B	Frame back 2		2X
C	Frame Seat		1X
D	Chair Leg		2X
E	Cushion seat		1X
F	Cushion Back		1X
G	Cushion Hip		2X
H	Pillow		2X

PIECE	DESCRIPTION	PICTURE	QUANTITY
I	Bolt	 M8x85	4X
J	Bolt	 M8x45	8X
K	Bolt	 M6x45	4X
L	Screw	 M7x90	1X
M	Washer	 M8.5/20X2	12X
N	Allen key	 LG4	1X

Product Dimensions: 50.9" W x 50.9" D x 34.5" H

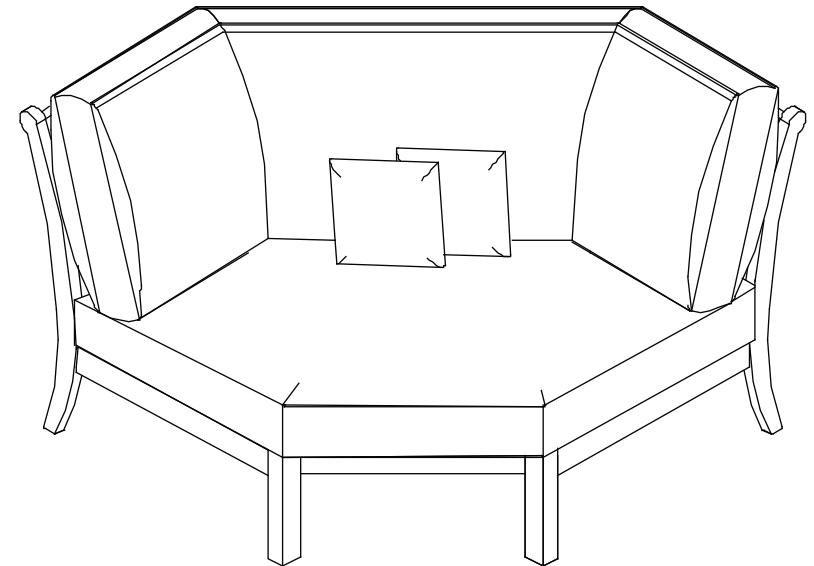

PREPARATION

Before beginning assembly of product, make sure all parts are present. Compare parts with package contents list and hardware contents list. If any part is missing or damaged, do not attempt to assemble the product.

Estimated Assembly Time: 10 minutes.

Tools Required for Assembly (included): Allen Key

1

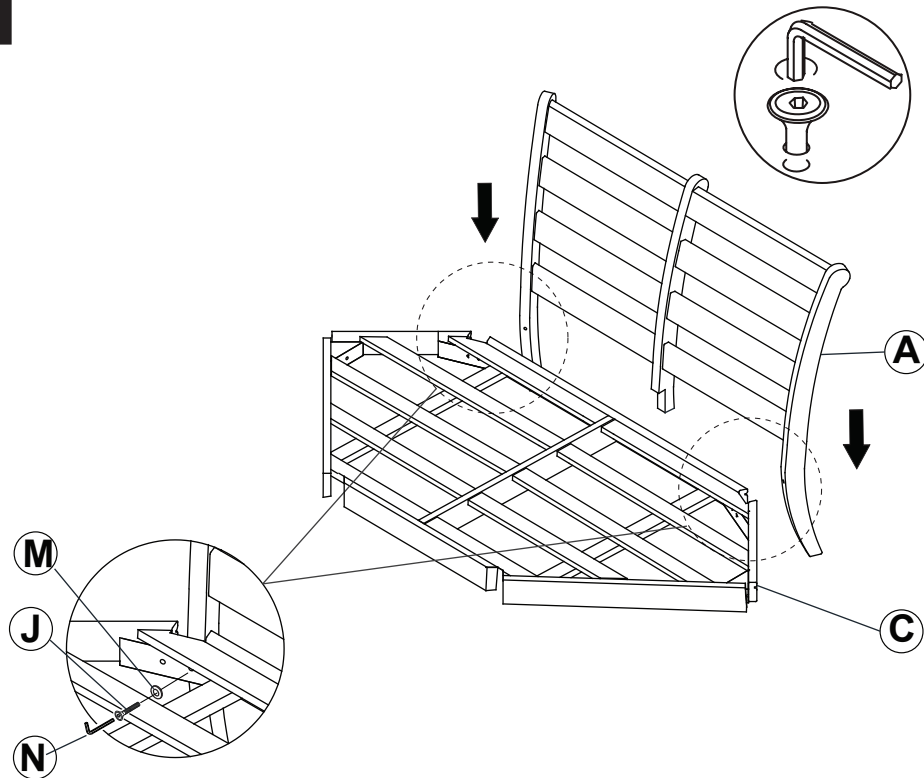

Step 1:
Attach Frame Back 1 (A) to Frame Seat (C), use Bolt (J) and Washer (M) tighten with allen key (N).

2

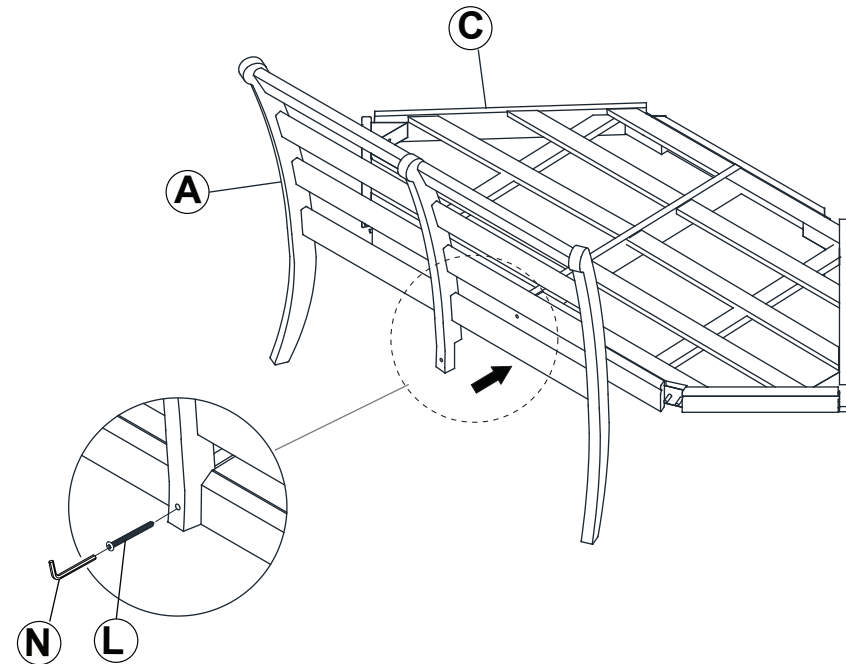

Step 2
Attach Frame Back (A) to Frame Seat (C), use Screw (L) tighten with allen key (N).

PREPARATION

Before beginning assembly of product, make sure all parts are present. Compare parts with package contents list and hardware contents list. If any part is missing or damaged, do not attempt to assemble the product.

Estimated Assembly Time: 10 minutes.

Tools Required for Assembly (included): Allen Key

3

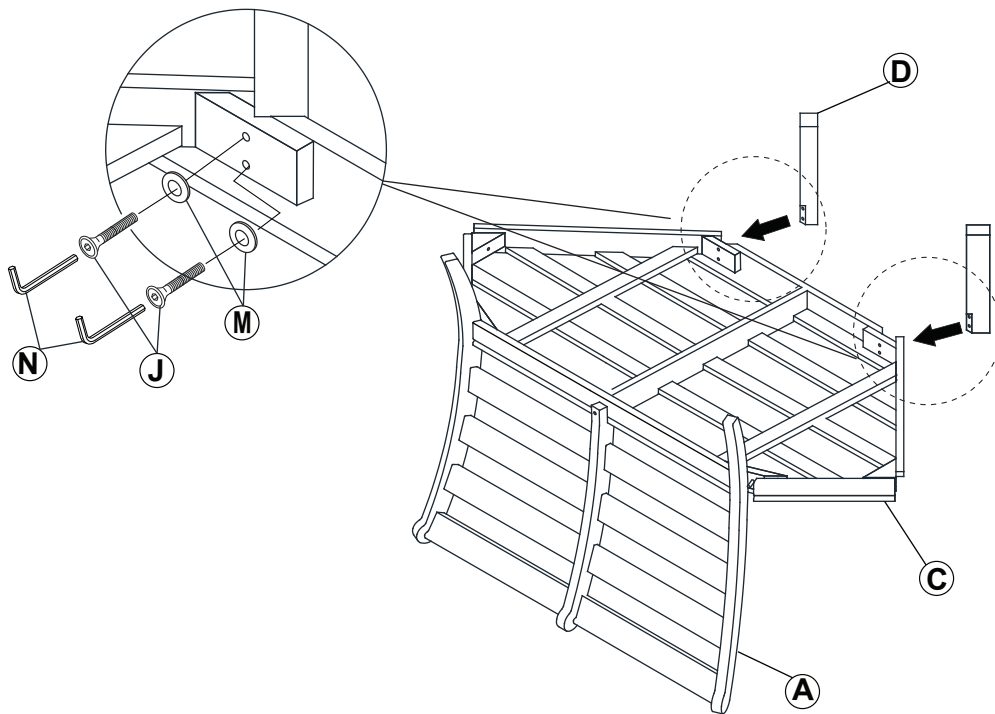

Step 3

Attach Chair leg (D) to Frame Seat (C), Use Bolt (J) and Washer (M) tighten with allen key (N).

4

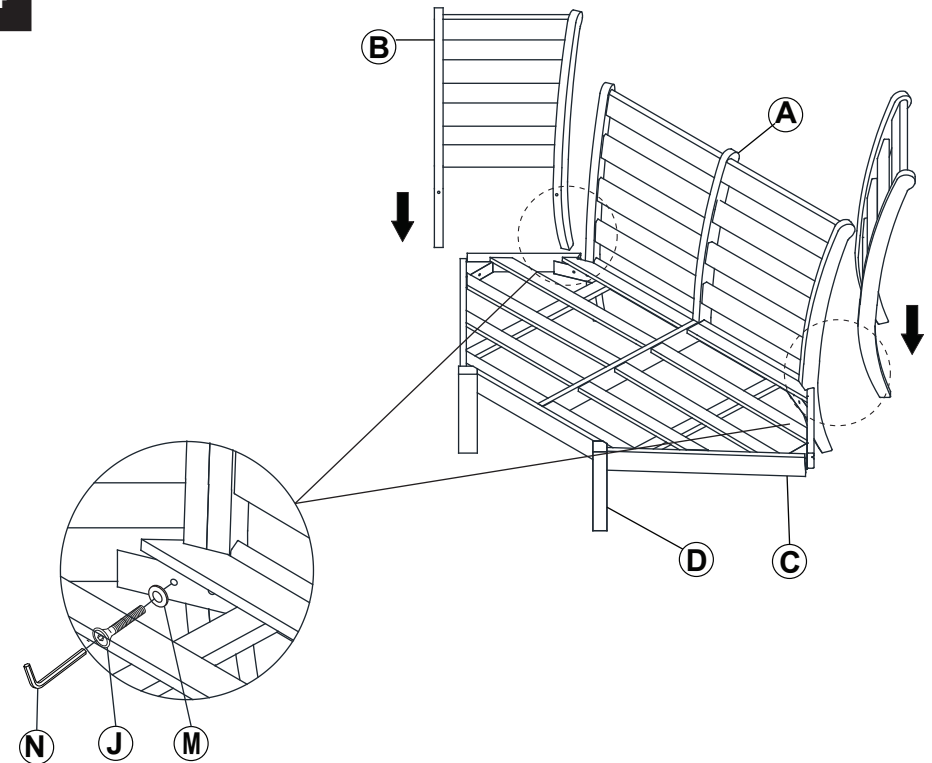

Step 4

Attach Frame Back 2 (B) to Frame Seat (C), Use Bolt (J) and Washer (M) tighten with allen key (N).

PREPARATION

Before beginning assembly of product, make sure all parts are present. Compare parts with package contents list and hardware contents list. If any part is missing or damaged, do not attempt to assemble the product.

Estimated Assembly Time: 10 minutes.

Tools Required for Assembly (included): Allen Key

5

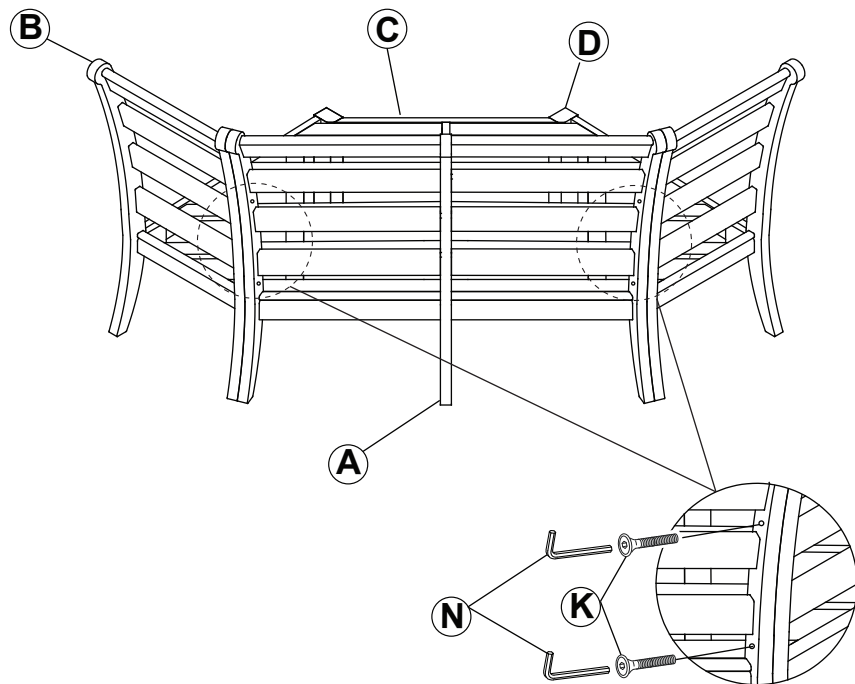

6

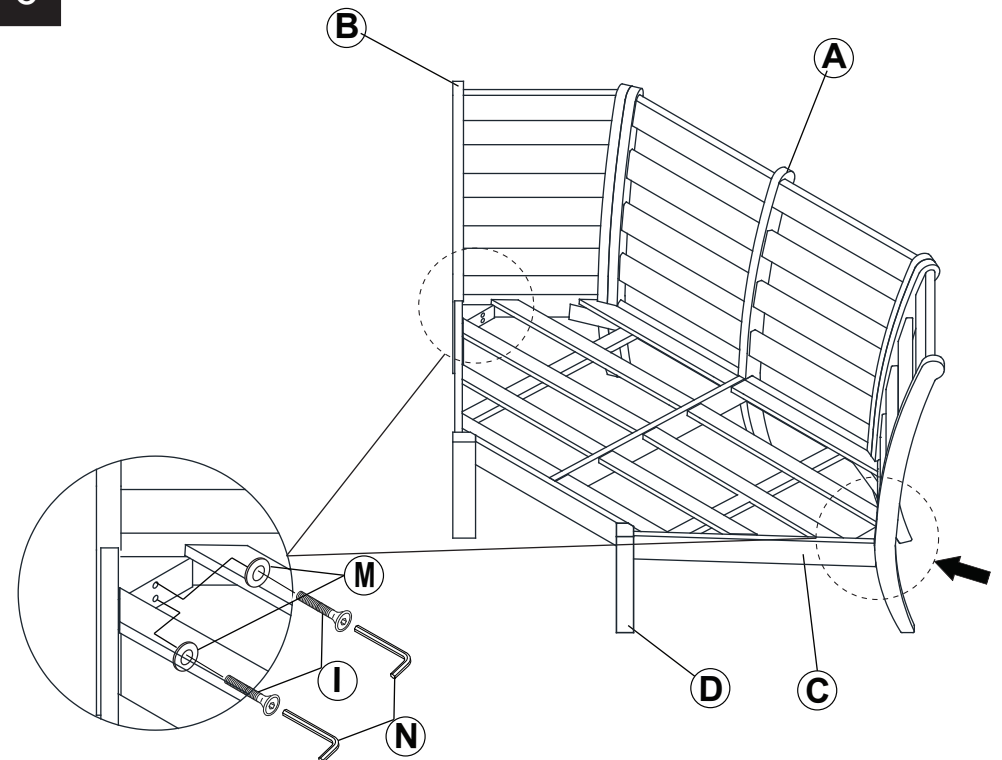

Step 5

Use Bolt (K) tighten with allen key (N).

Step 6

Use Bolt (I) and Washer (M) tighten with allen key (N).

PREPARATION

Before beginning assembly of product, make sure all parts are present. Compare parts with package contents list and hardware contents list.
If any part is missing or damaged, do not attempt to assemble the product.

Estimated Assembly Time: 10 minutes.

Tools Required for Assembly (included): Allen Key

7

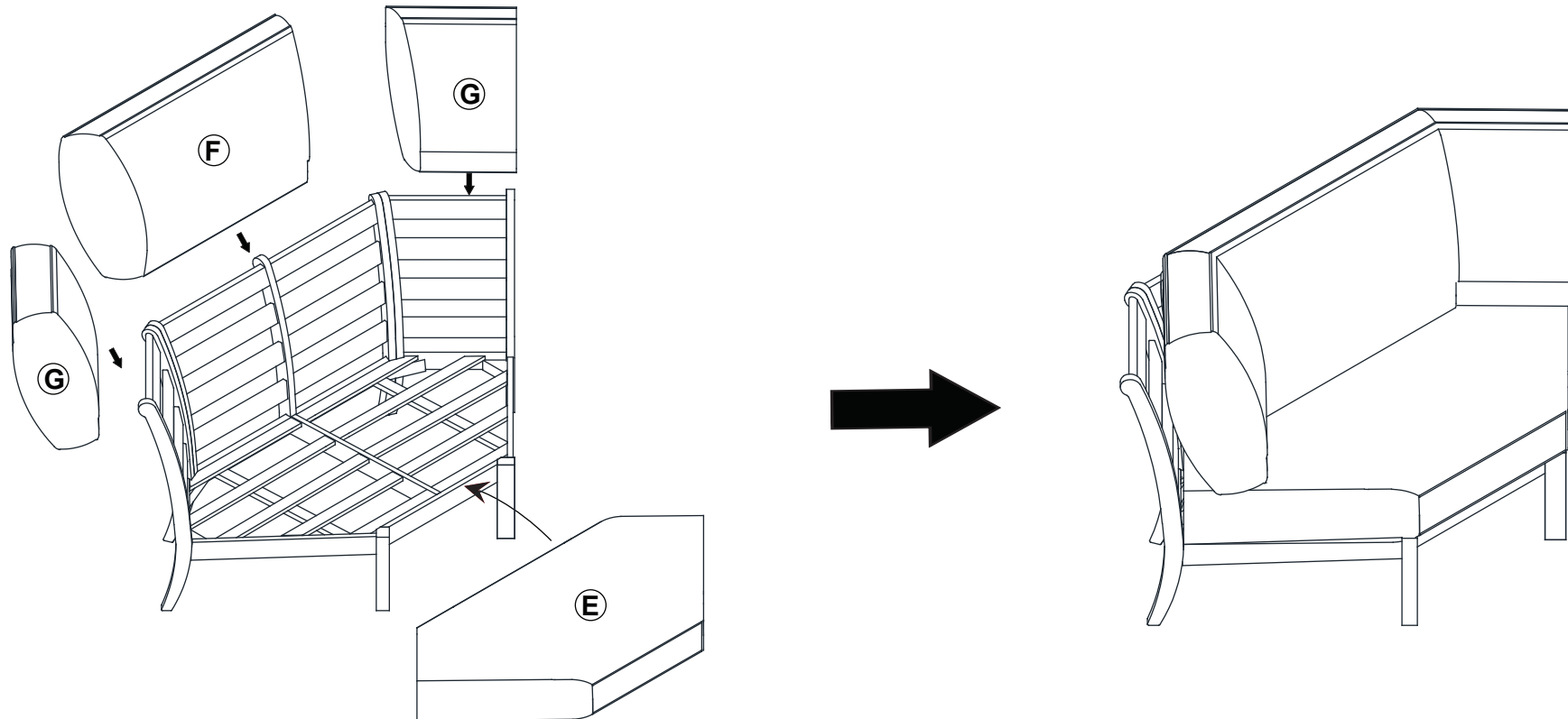

Step 7
Attach Cushion seat (E), Cushion Hip (G) and Cushion back (F).Complete