

PL - Przed rozpoczęciem zapoznać się z instrukcją montażu /  
DE- Vor die montage, bitte beiliegende anweisungen folgen /  
EN- Before starting, refer to the assembling advice in annex /  
CZ- Před zahájením naleznete v montážním návodu /  
SK- Pred začatím nájdete v montážnom návode /  
RU- Перед началом обратитесь к инструкции по установке /  
SRB- Пре почетка pogledajte uputstva za instalaciju /  
HR- Prije početka pogledajte upute za instalaciju /

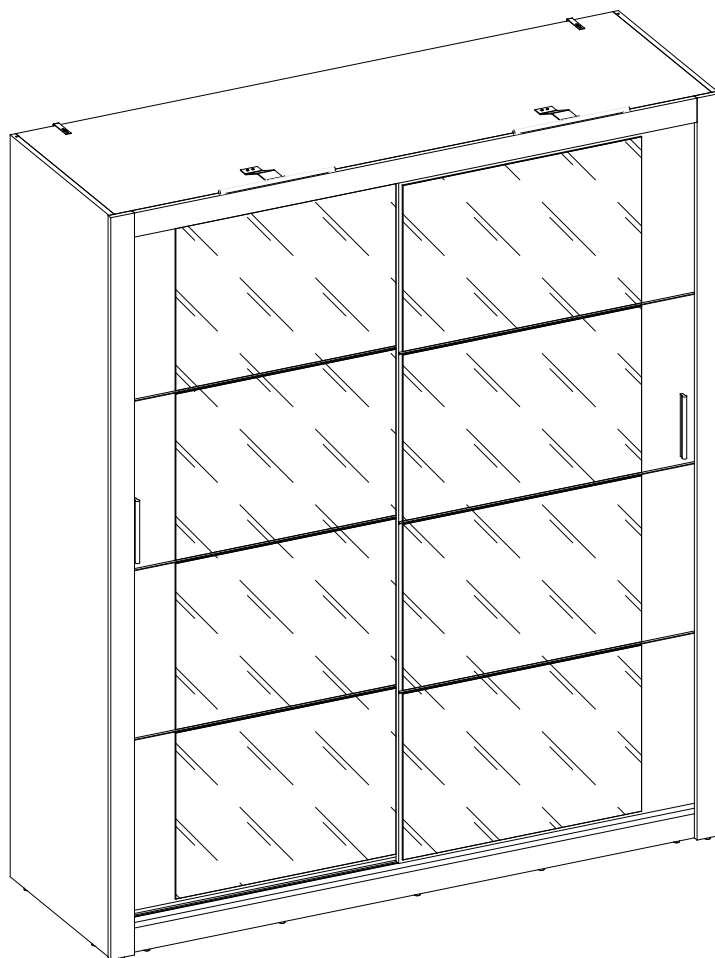

180 min

180x215.5x60 cm

Potrzebne narzędzia/ Benötigtes Werkzeug/ Required tools/ Potřebné nástroje/ Potrebne nástroje/ Необходимые инструменты/ Potreban alat

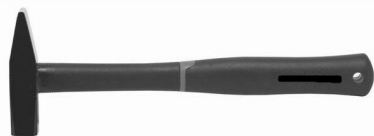
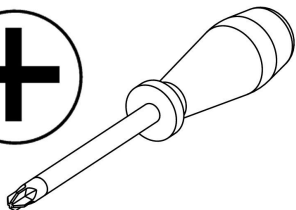

2x

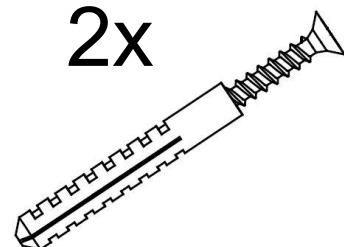

PL wymiary elementów  
 EN the dimensions of the elements  
 DE Abmessungen der Elemente  
 CZ rozměry prvků  
 SK rozmery prvkov  
 RU размеры элементов

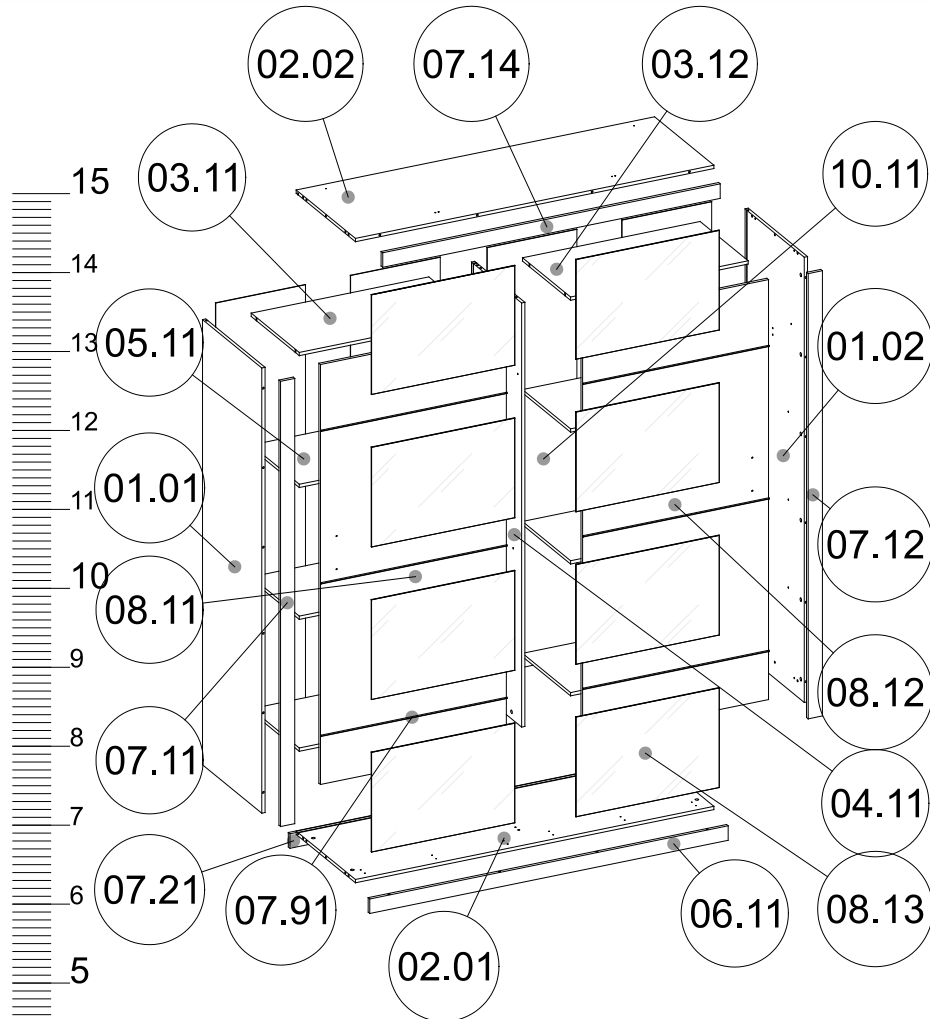

01.01	584	1	1/4
01.02	584	1	1/4
02.01	584	1	2/4
02.02	584	1	2/4
03.11	474	1	3/4
03.12	474	1	3/4
04.11	494	1	2/4
05.11	474	6	3/4
06.11	70	1	1/4
07.11	70	1	1/4
07.12	70	1	1/4
07.14	70	1	1/4
07.21	70	1	1/4
07.91	3	6	4/4
08.11	916.5	1	4/4
08.12	916.5	1	4/4
08.13	481	8	4/4
10.11	442	4	1/4

OPTIONAL LIGHT

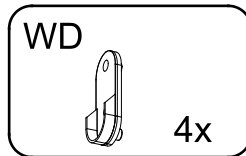
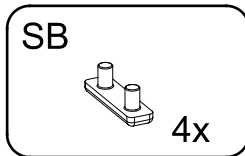
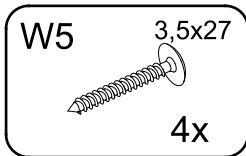
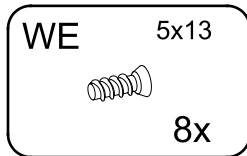
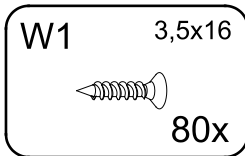
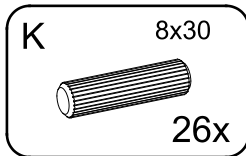
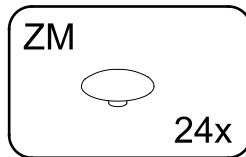
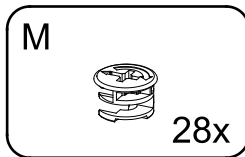
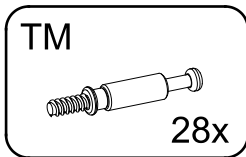
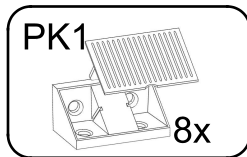
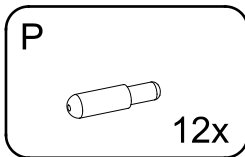
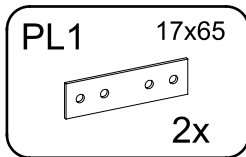
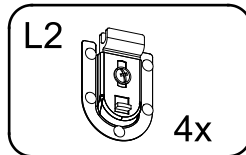
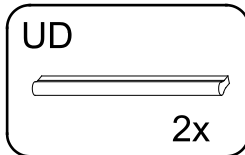
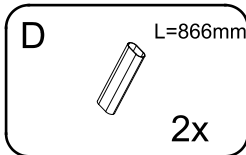
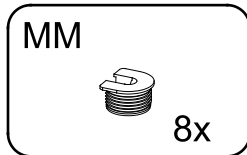
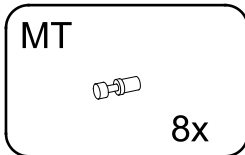
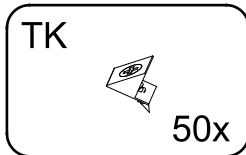
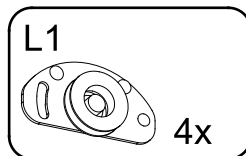
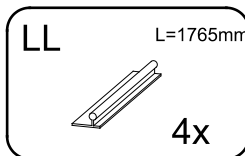
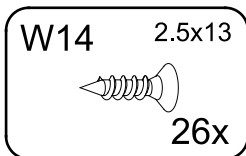
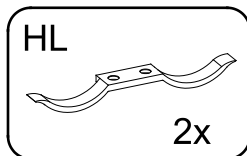
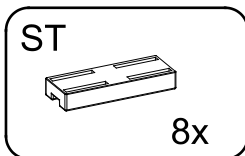
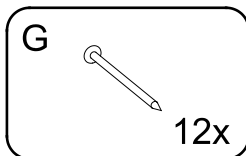
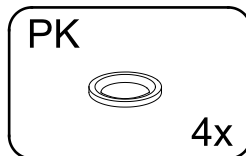
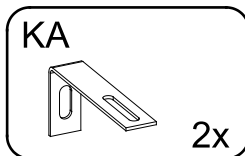
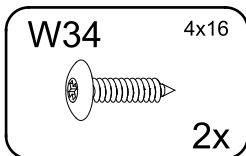
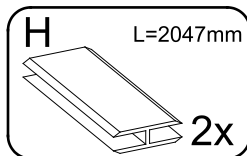
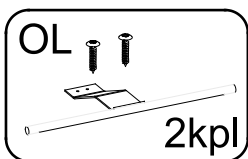

Proszę sprawdzić kompletność okuć przed montażem  
 Bitte überprüfen Sie die Vollständigkeit der Fittings vor der Montage  
 Please check the completeness of the fittings before assembly  
 Пожалуйста, проверьте комплектность фурнитуры перед установкой

Prosím zkontrolujte úplnost konektorů před instalací  
 Prosím skontrolujte úplnosť konektorov pred inštaláciou  
 Prije montaže provjerite cjelovitost okova  
 Pre postavljanja proverite kompletnost okova

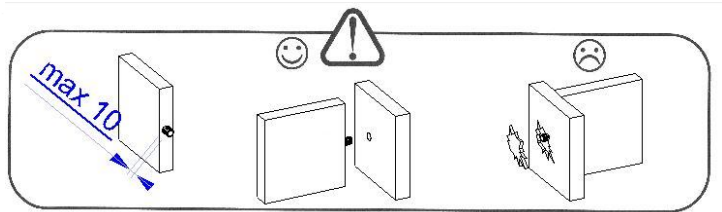
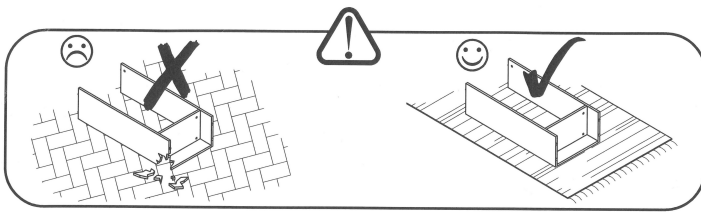

1

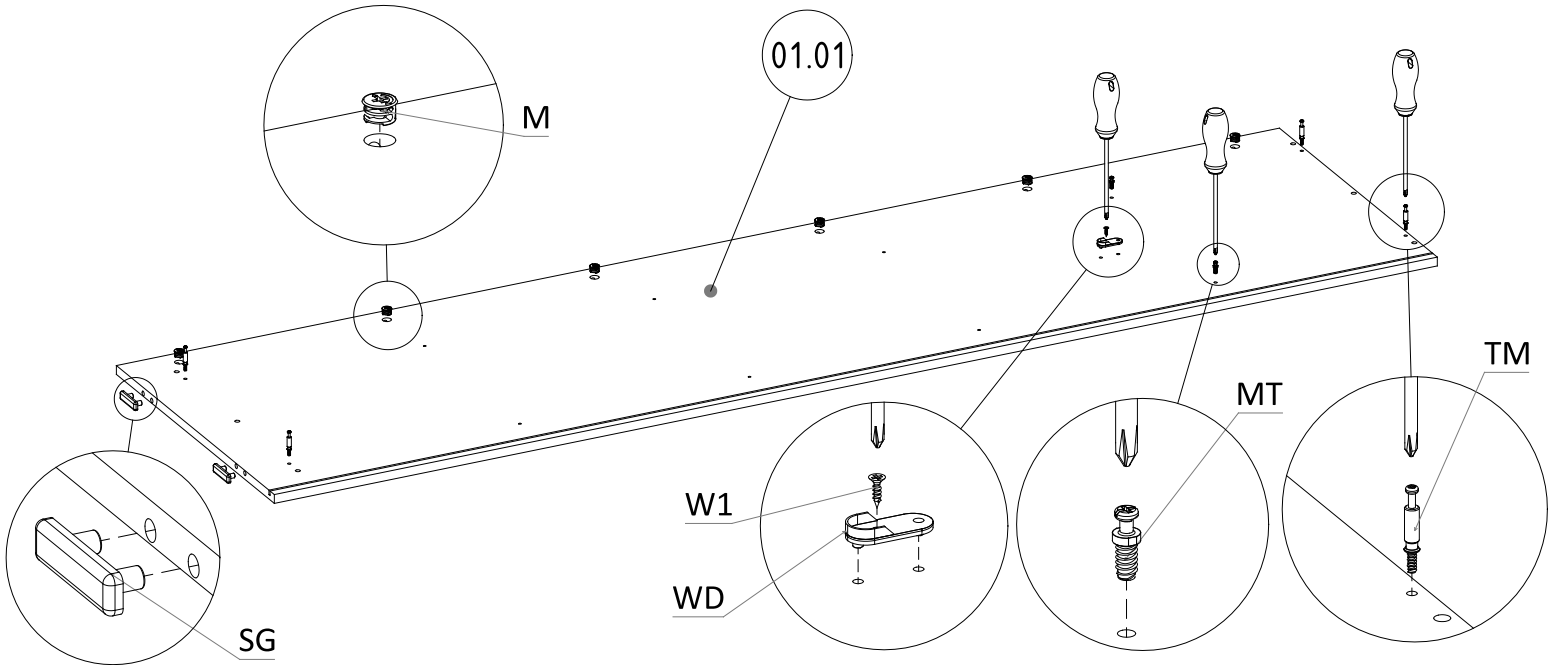
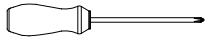
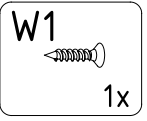
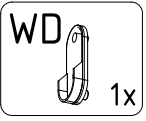
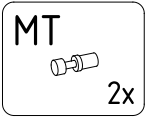
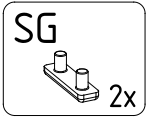
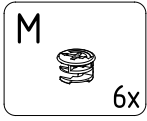
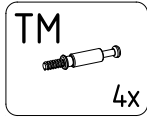

2

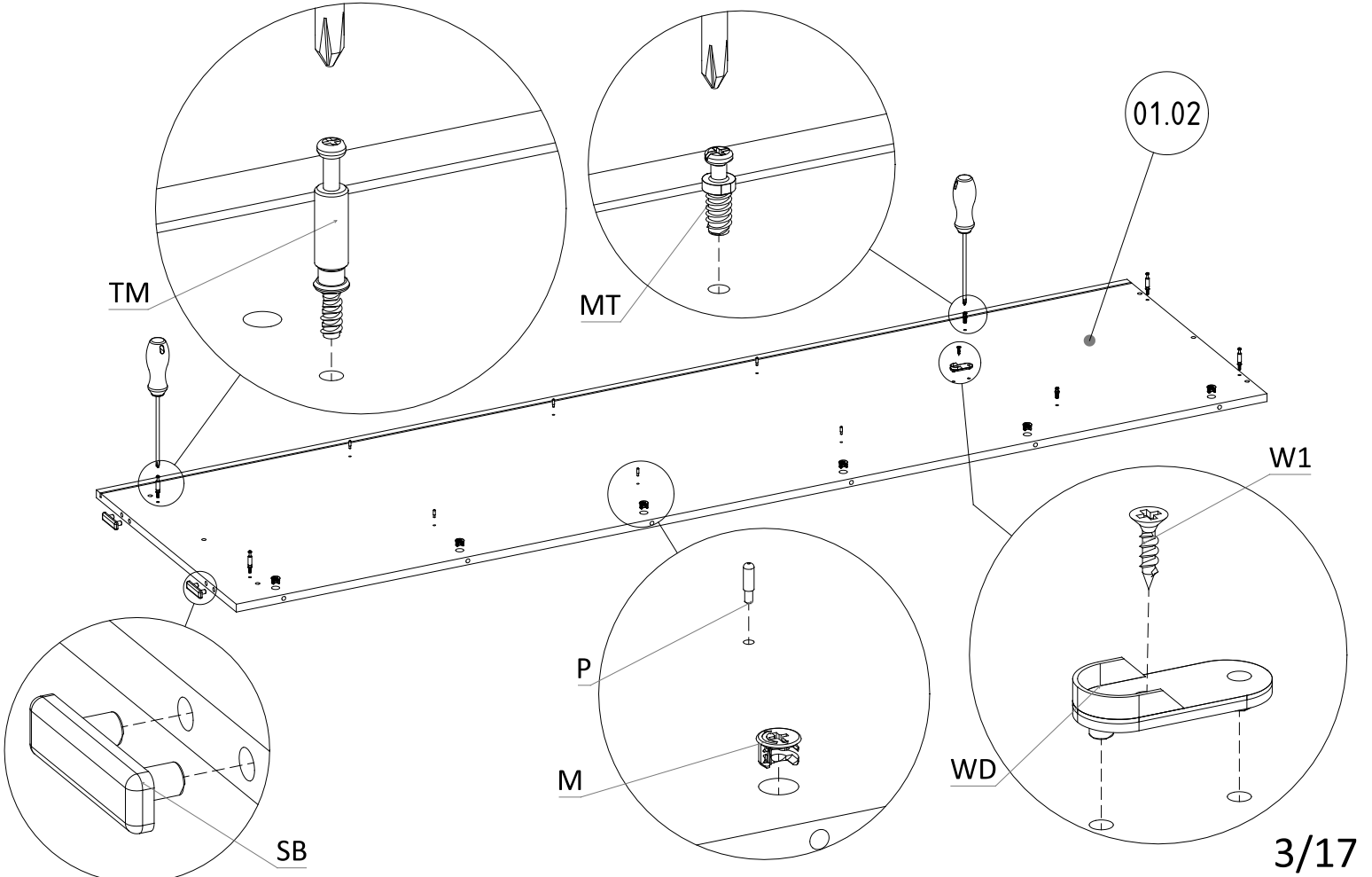
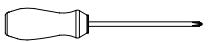
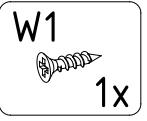
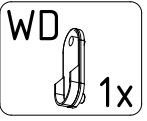
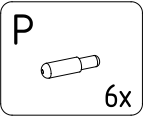
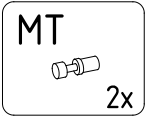
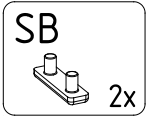
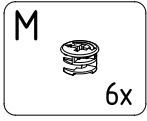
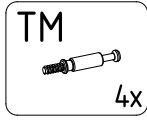

# 3

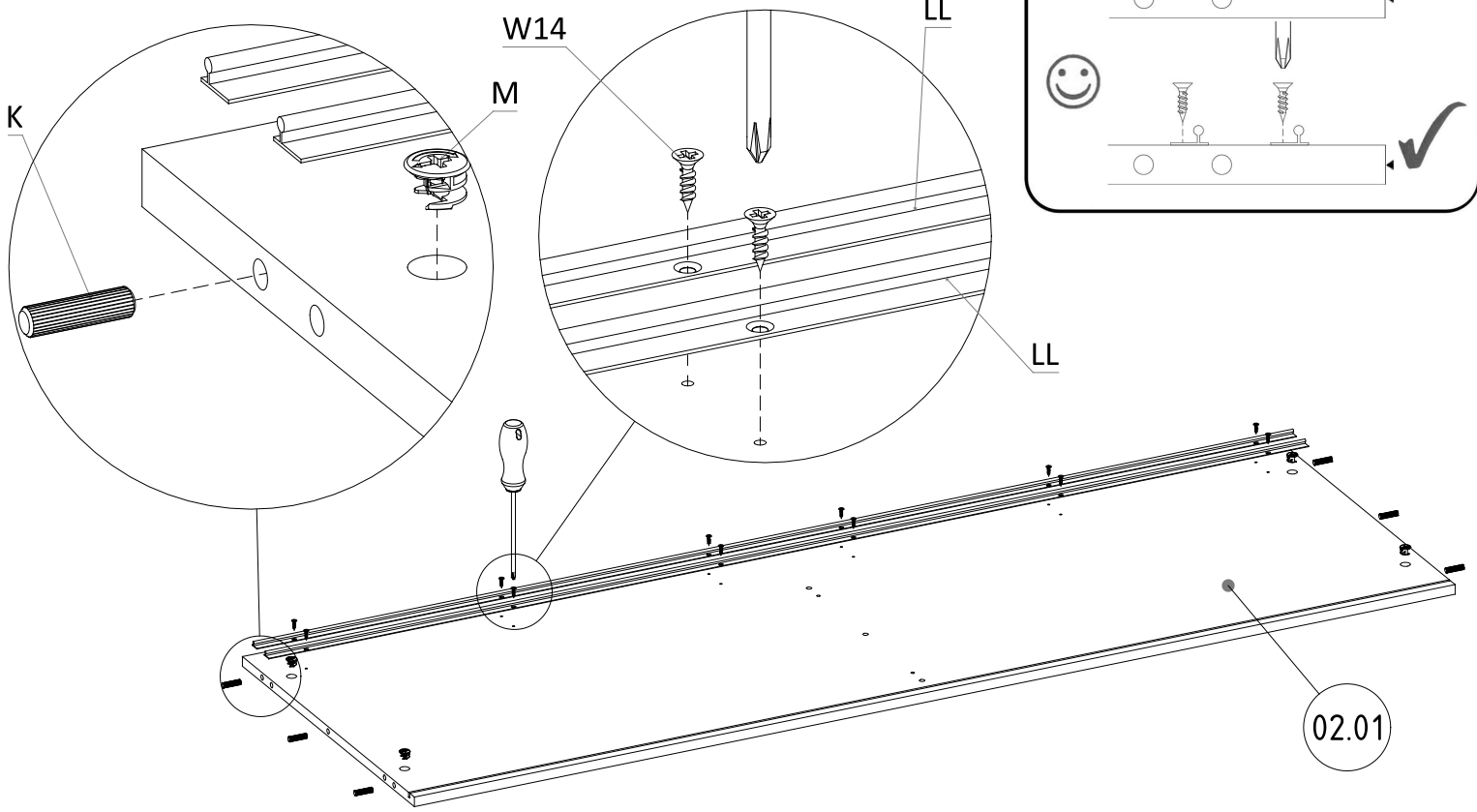
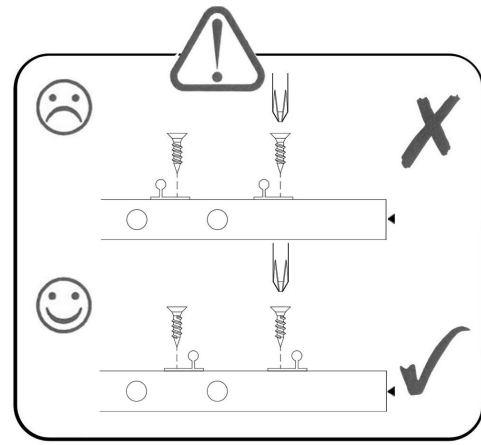
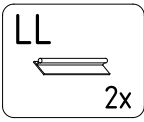
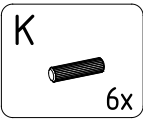
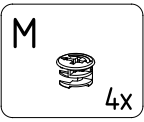
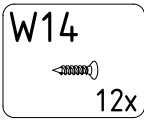

# 4

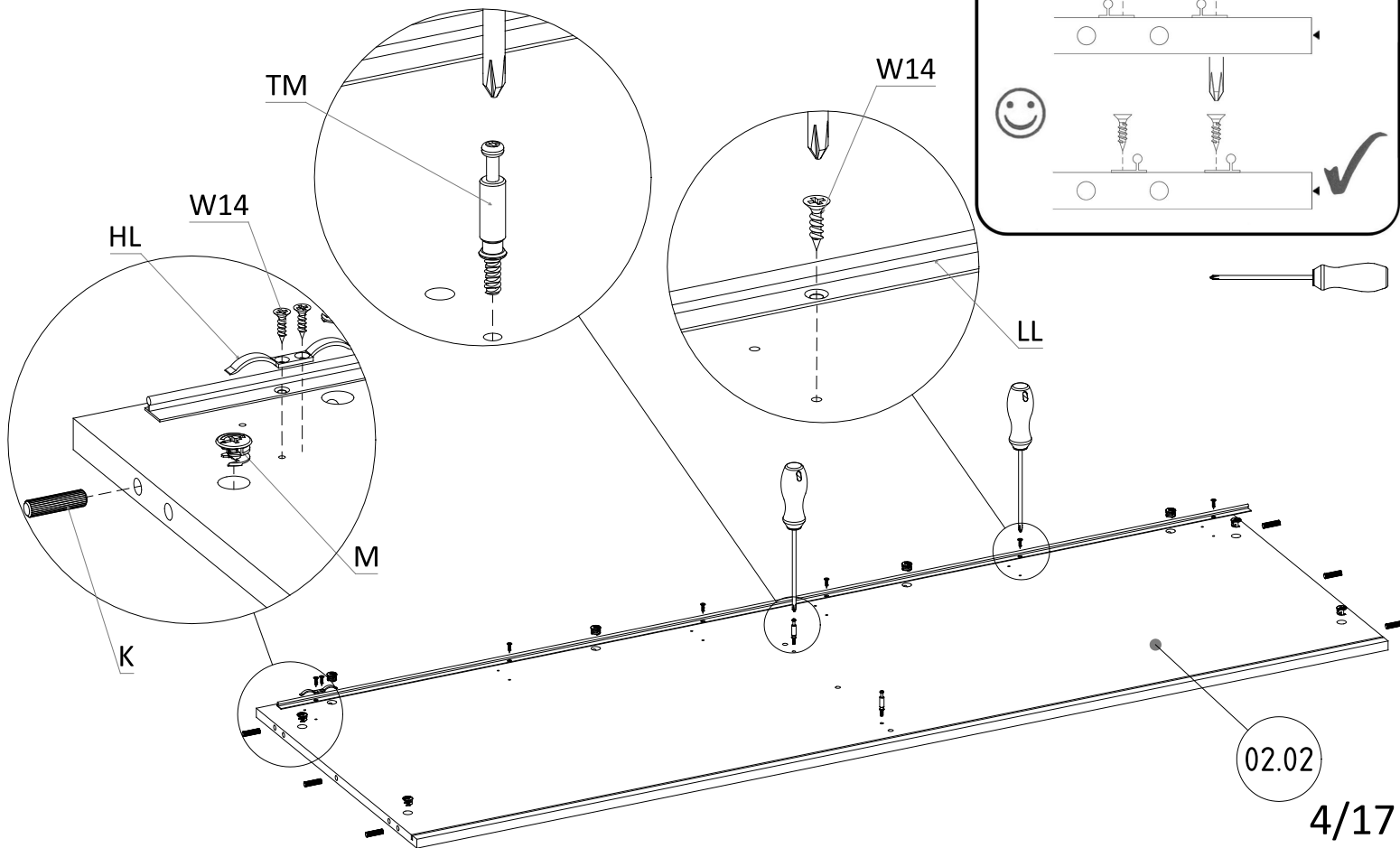
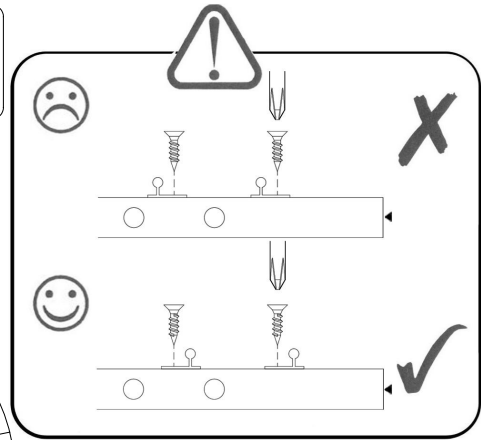
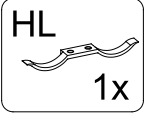
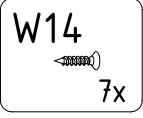
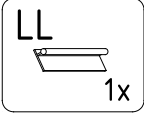
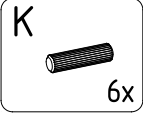
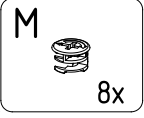
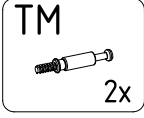

# 5

- K** 6x
- M** 4x
- WD** 2x
- W1** 2x
- MT** 4x
- P** 6x

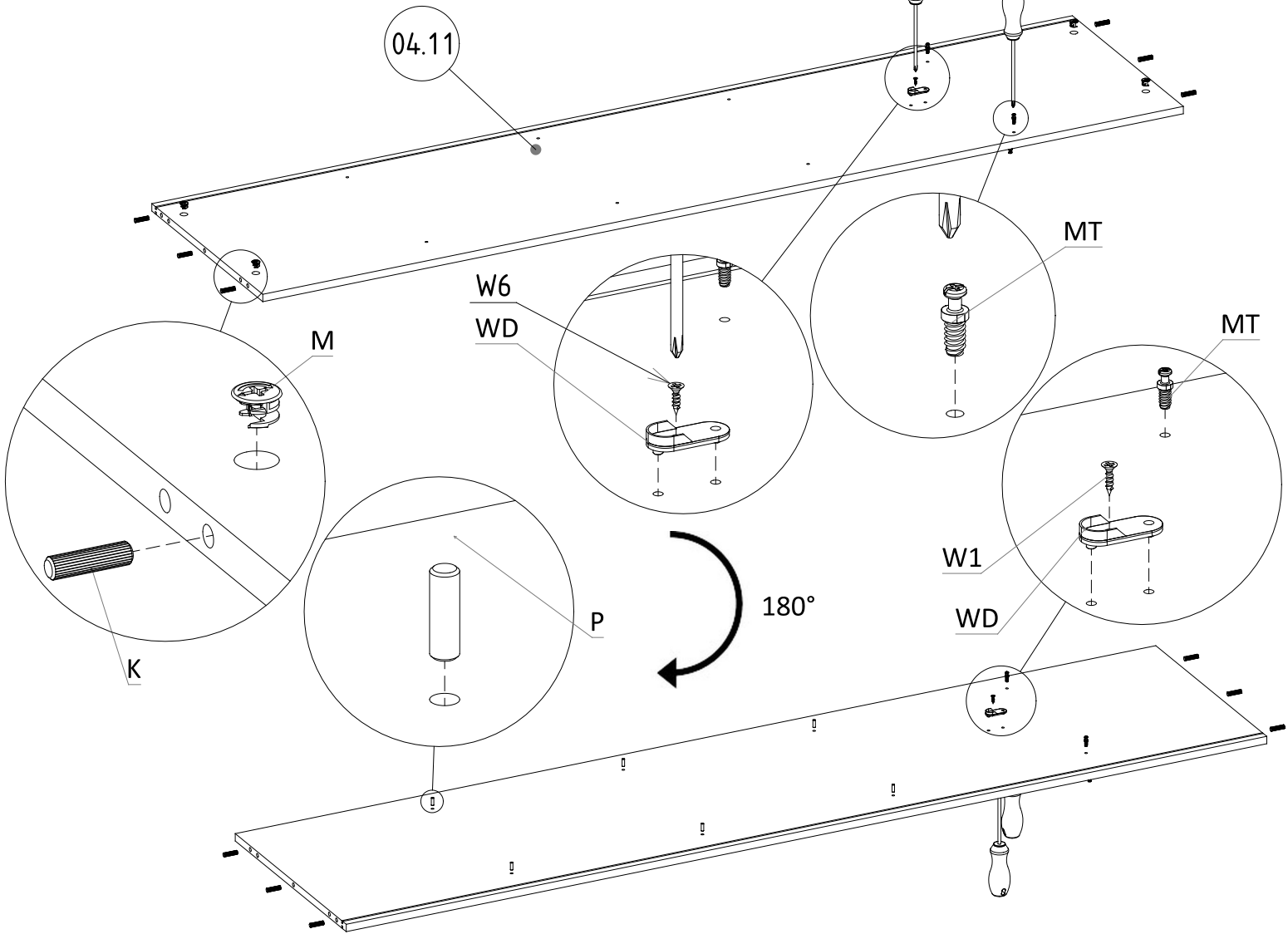
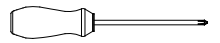

# 6

- MM** 4x2

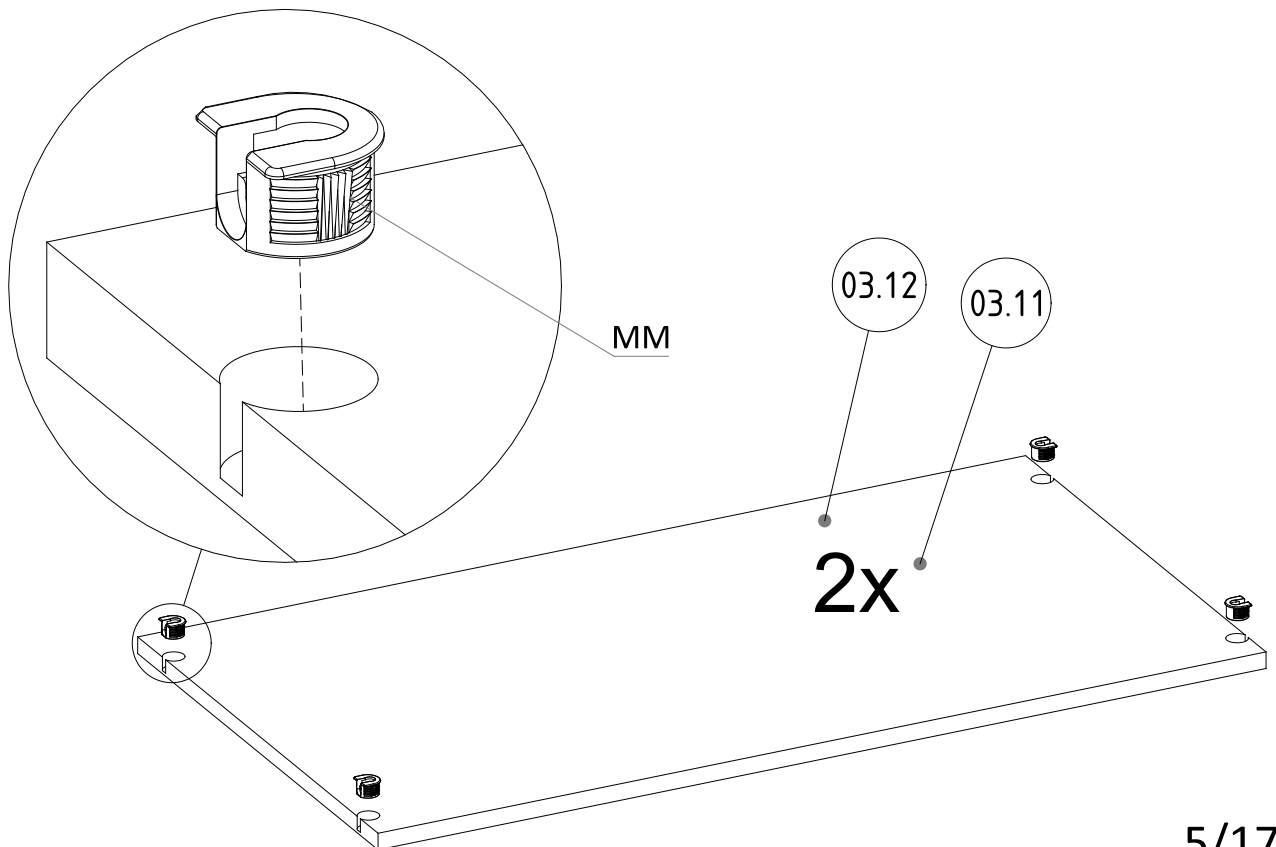

# 7

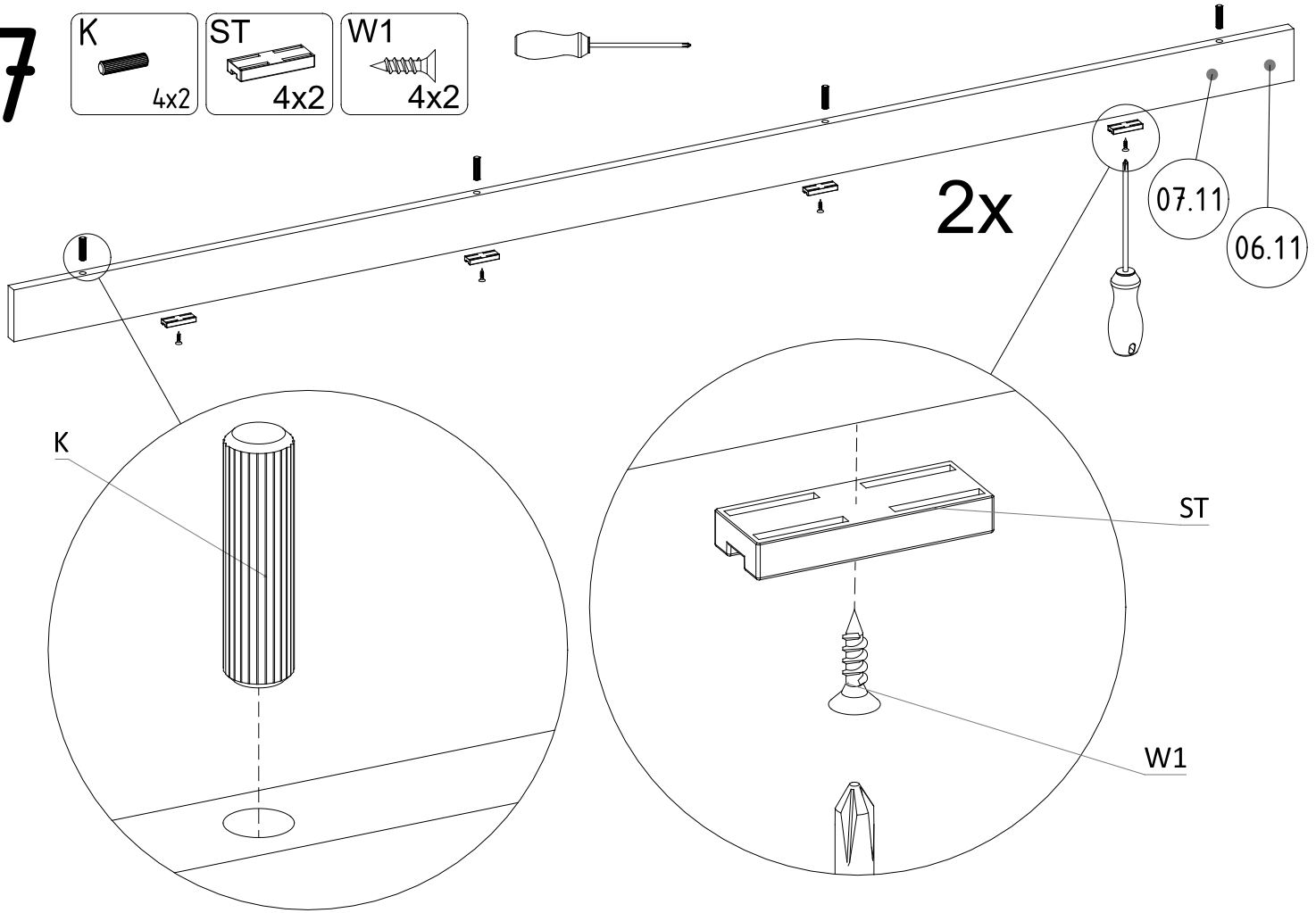
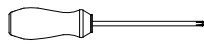
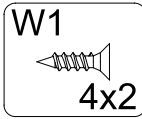
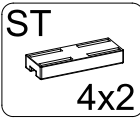
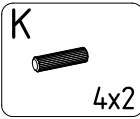

# 8

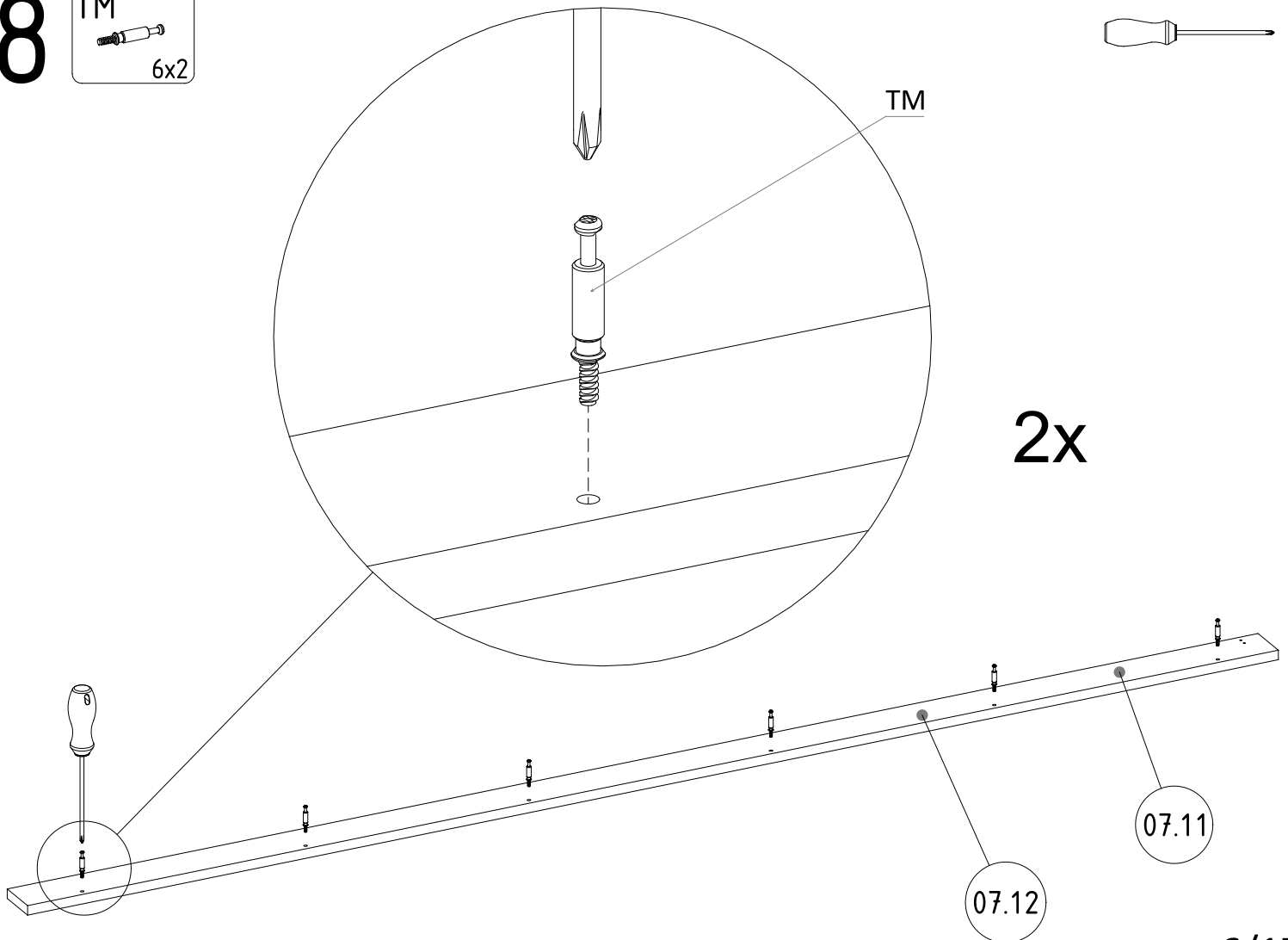
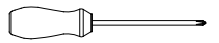
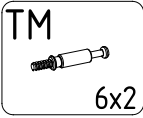

# 9

- PL1 2x
- W1 4x
- TM 4x

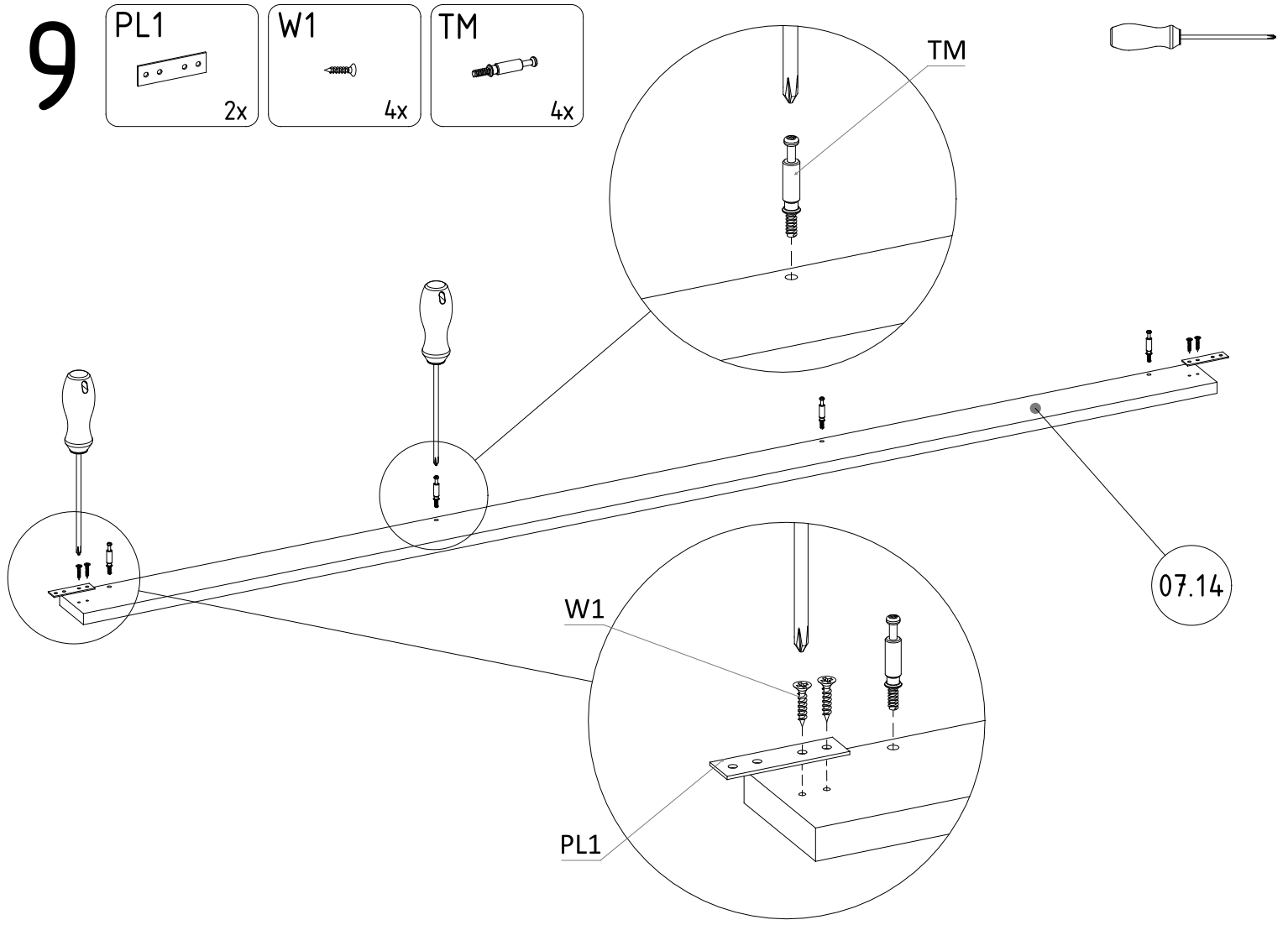

# 10

- L2 2x
- L1 2x
- W1 14x
- WE 4x
- PK 2x

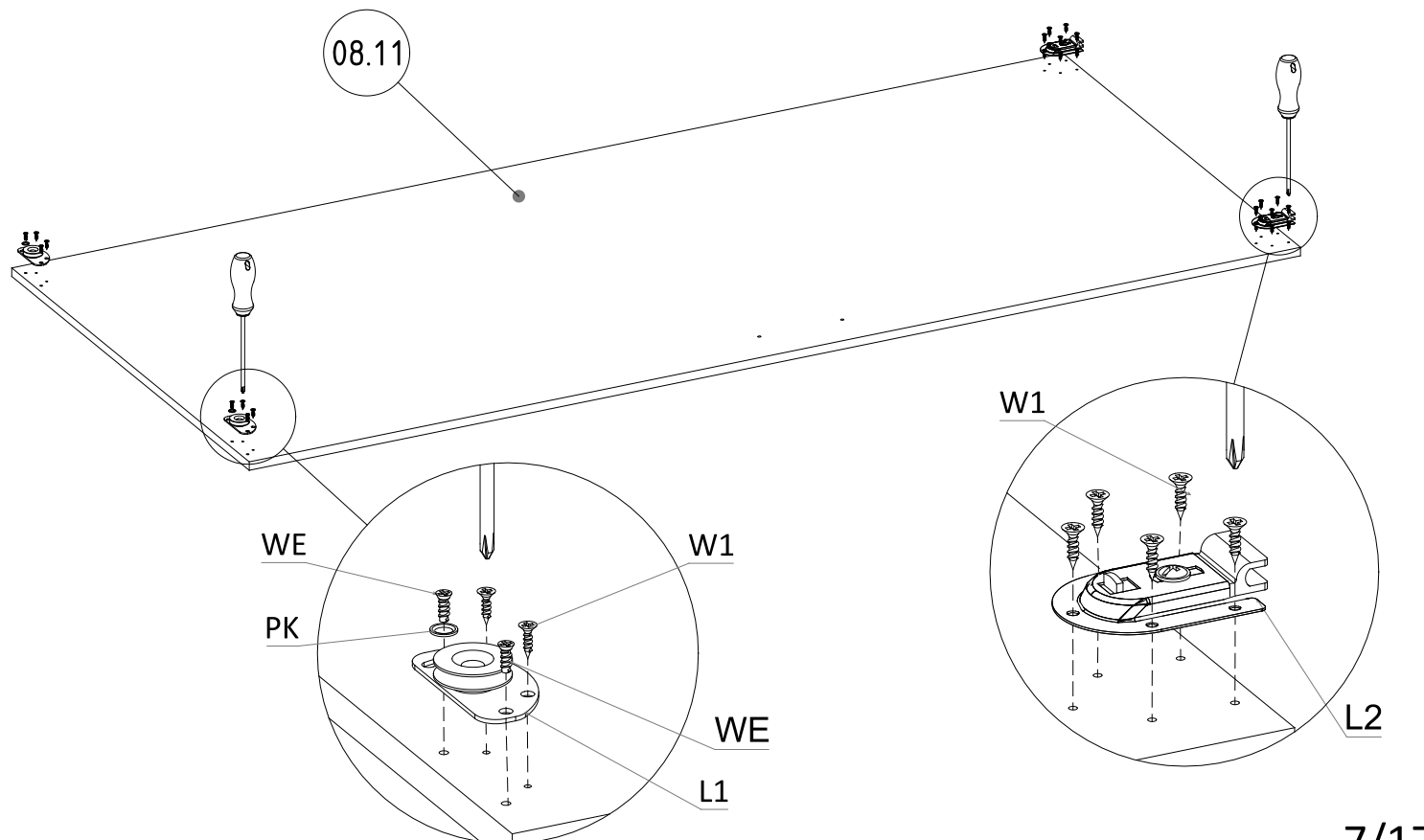

# 11

- L2 2x
- L1 2x
- W1 14x
- WE 4x
- PK 2x

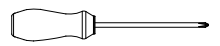

08.12

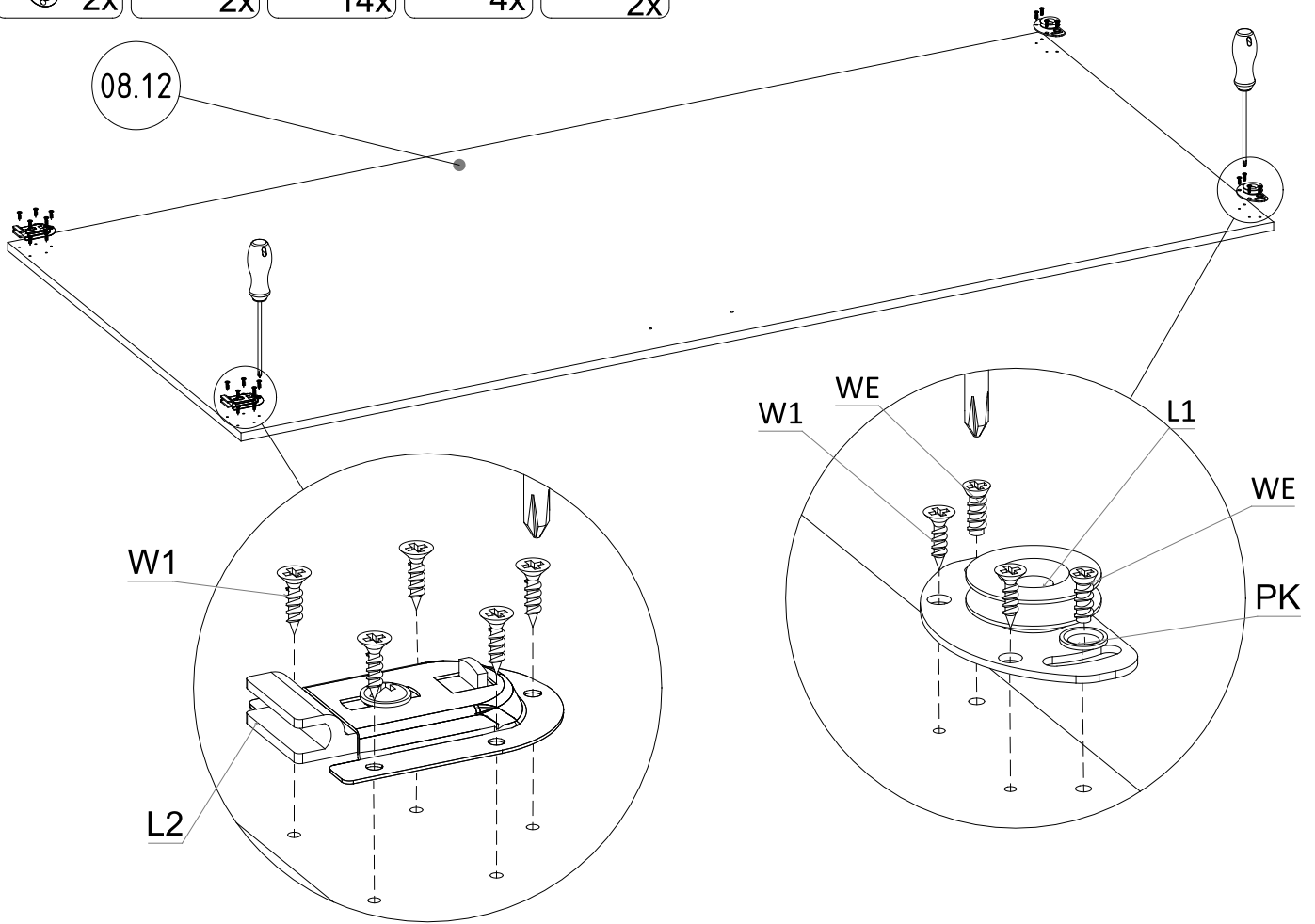

# 12

- PK1 8x
- W1 32x

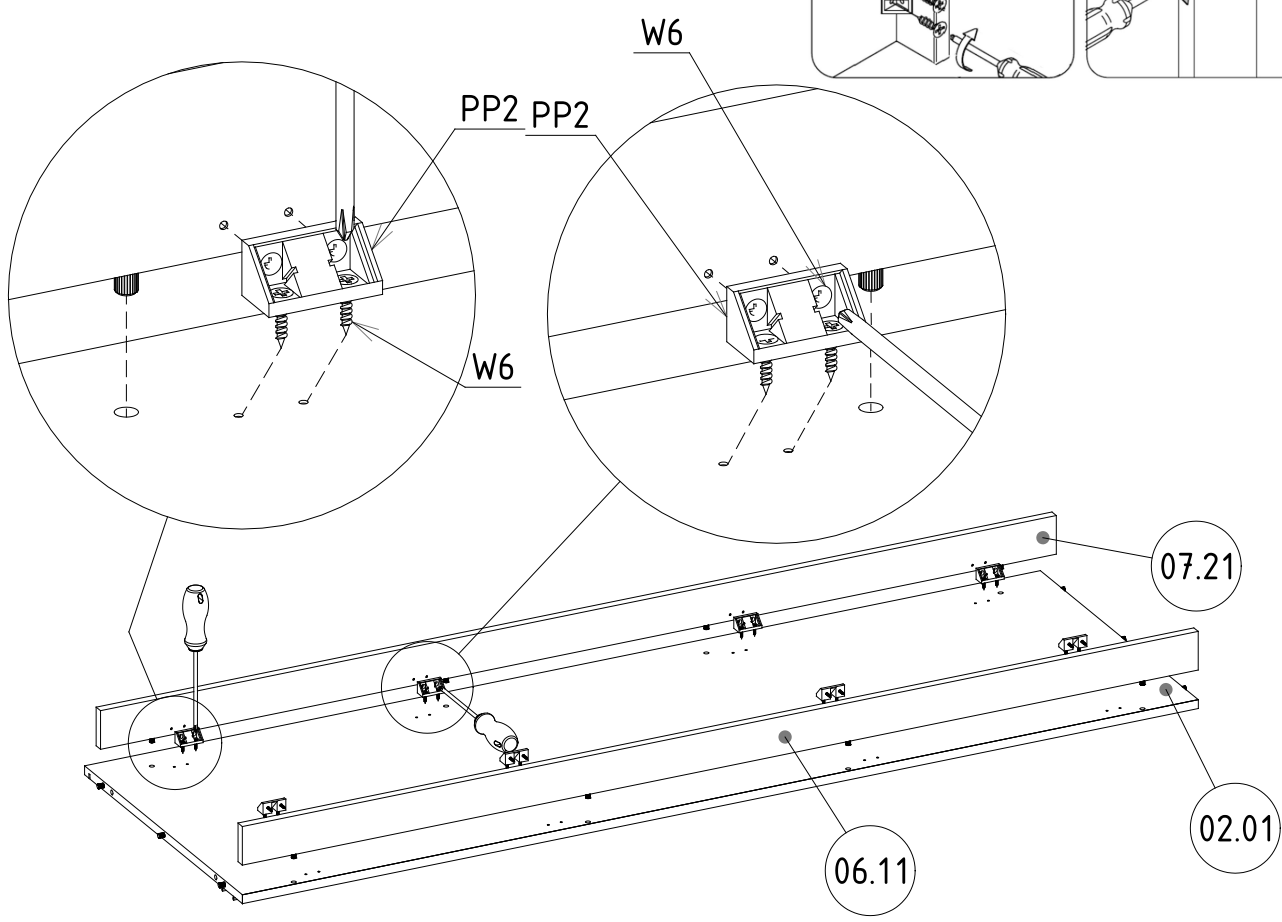
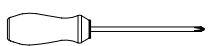
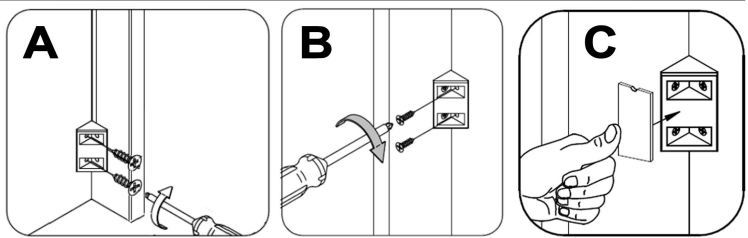

# 13

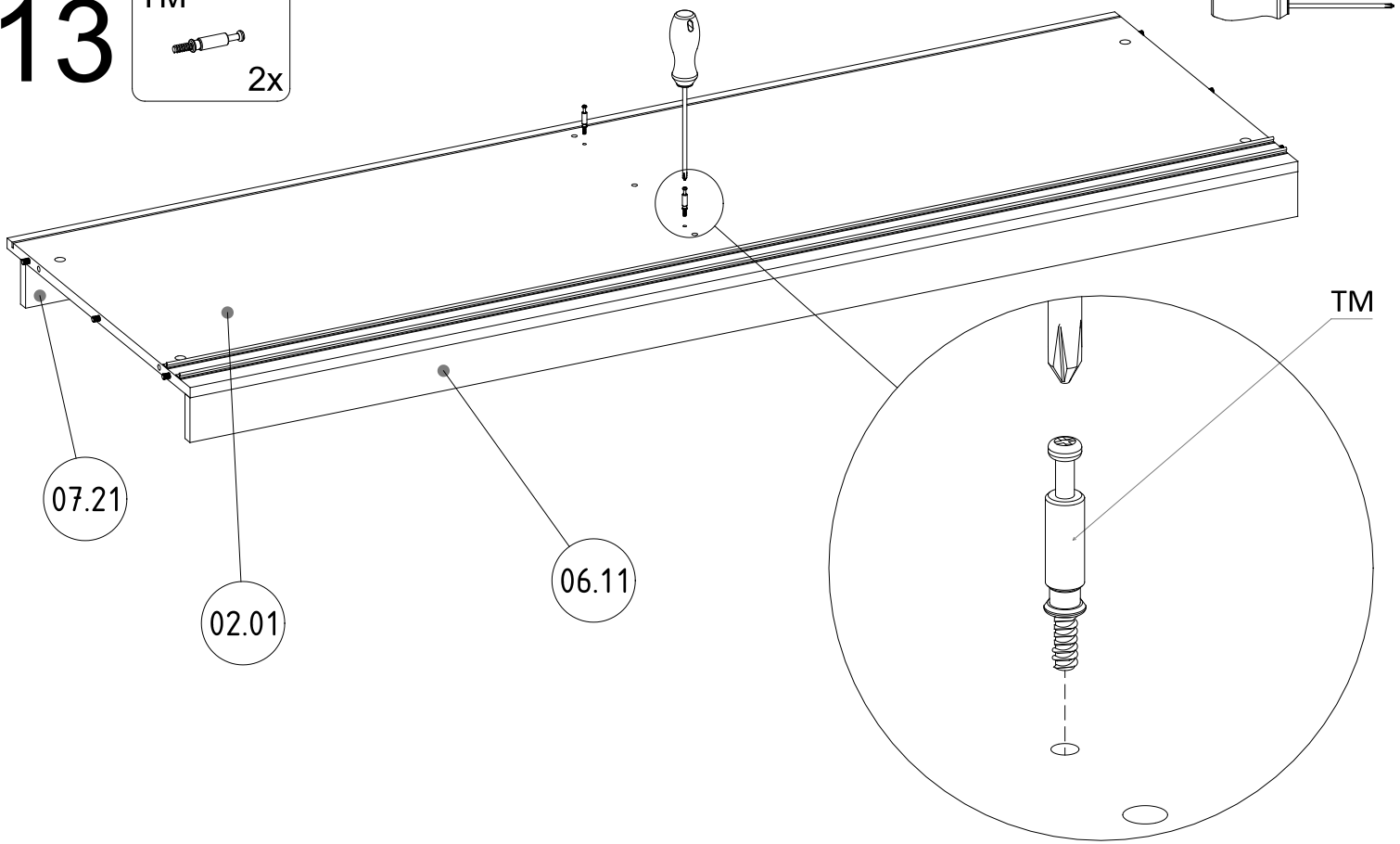
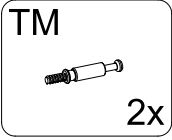

# 14

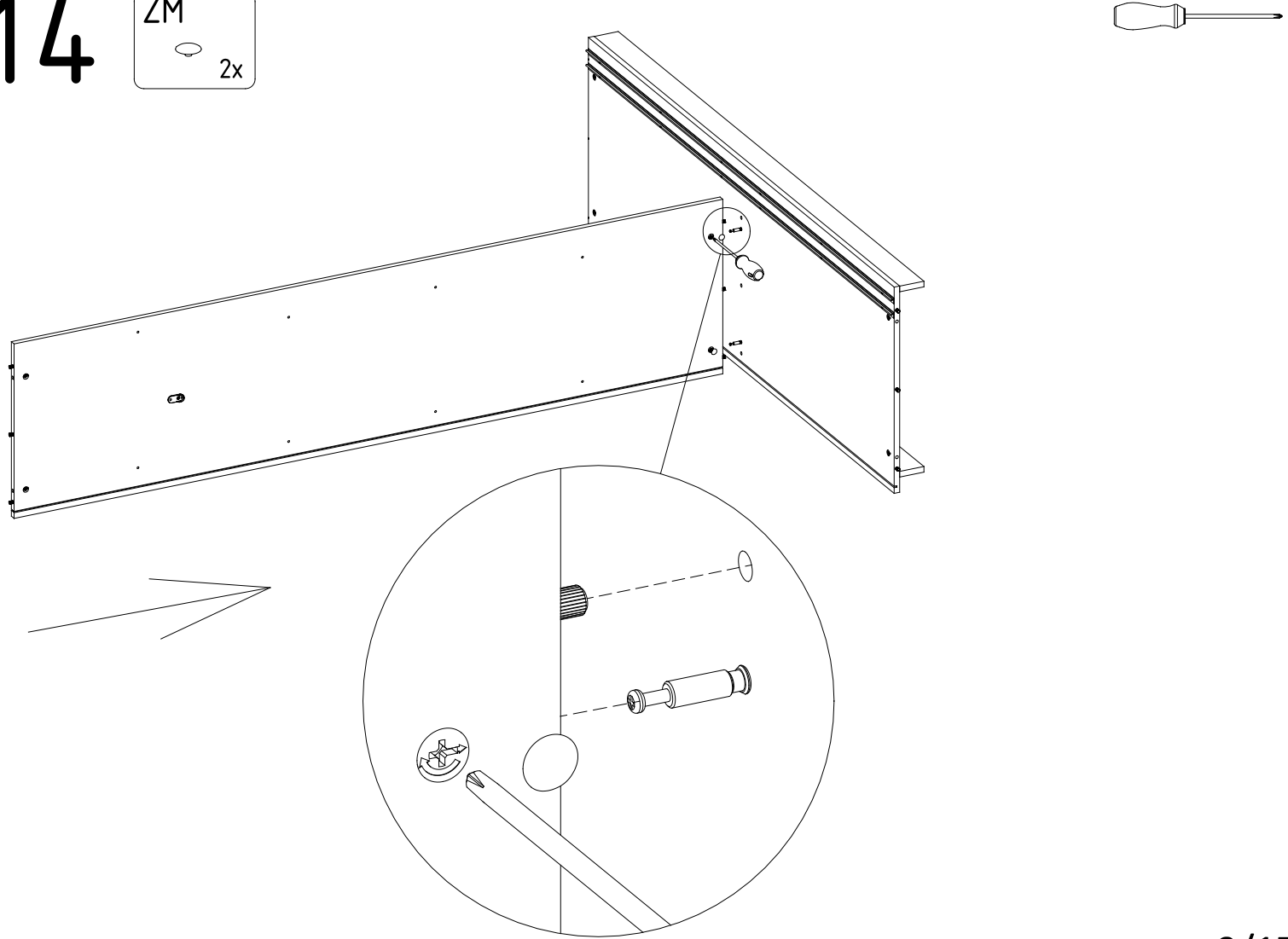
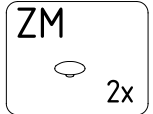

# 15

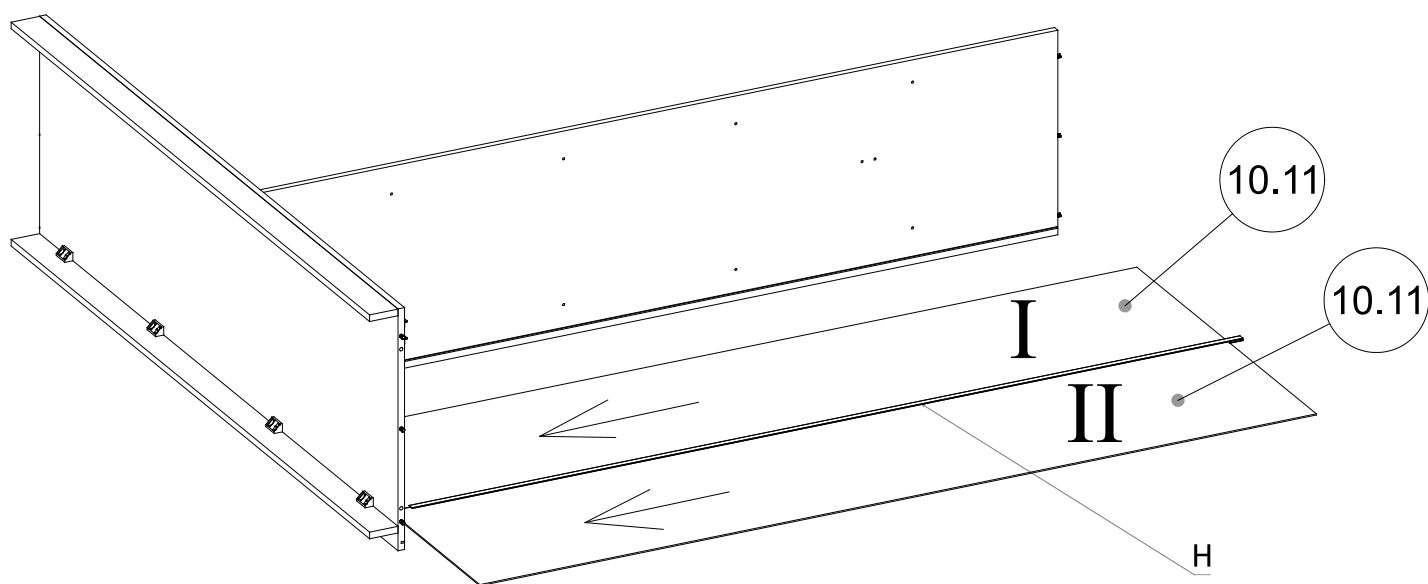
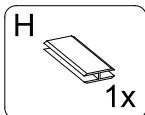

# 16

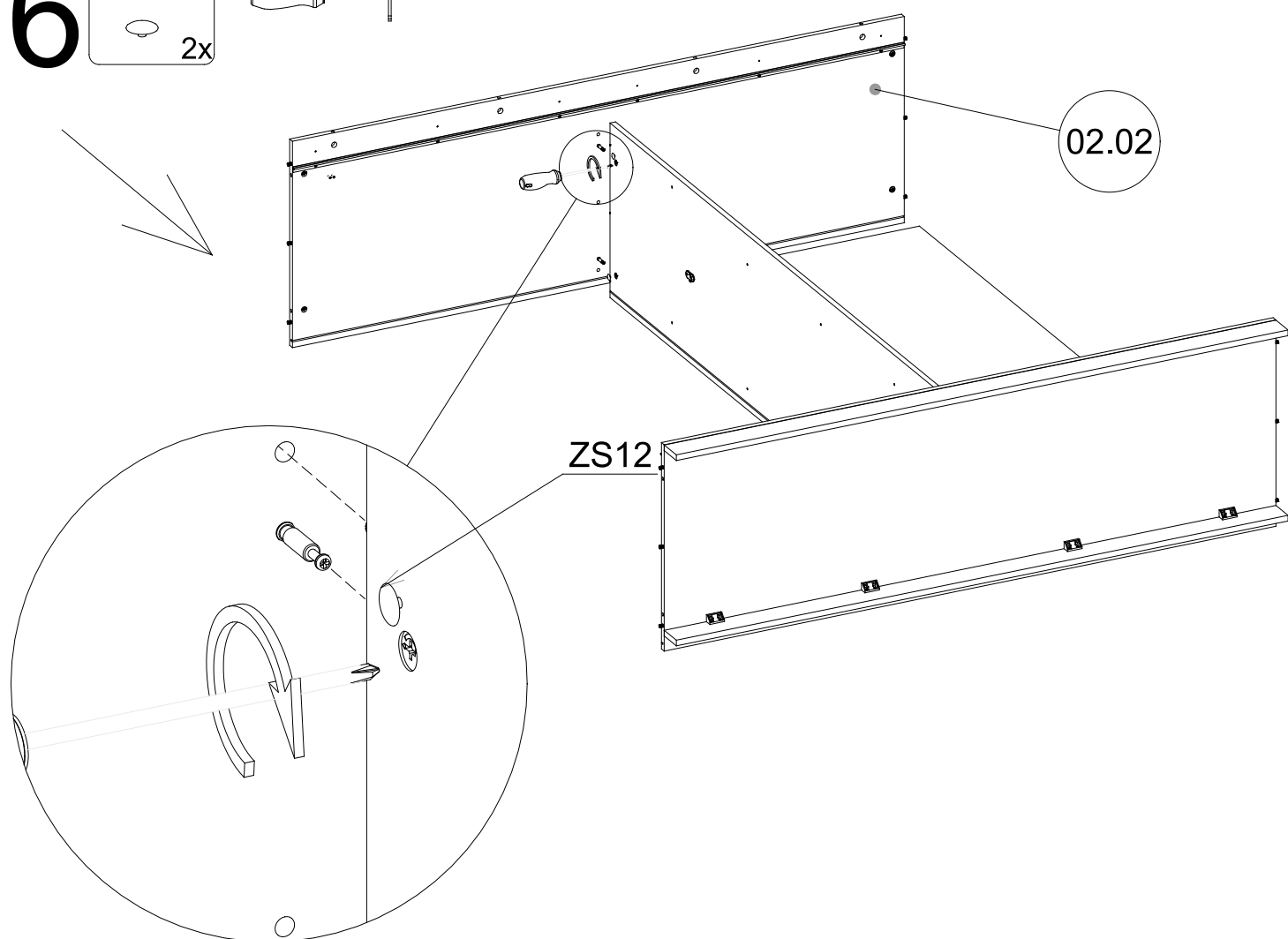
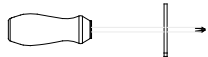
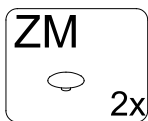

# 17

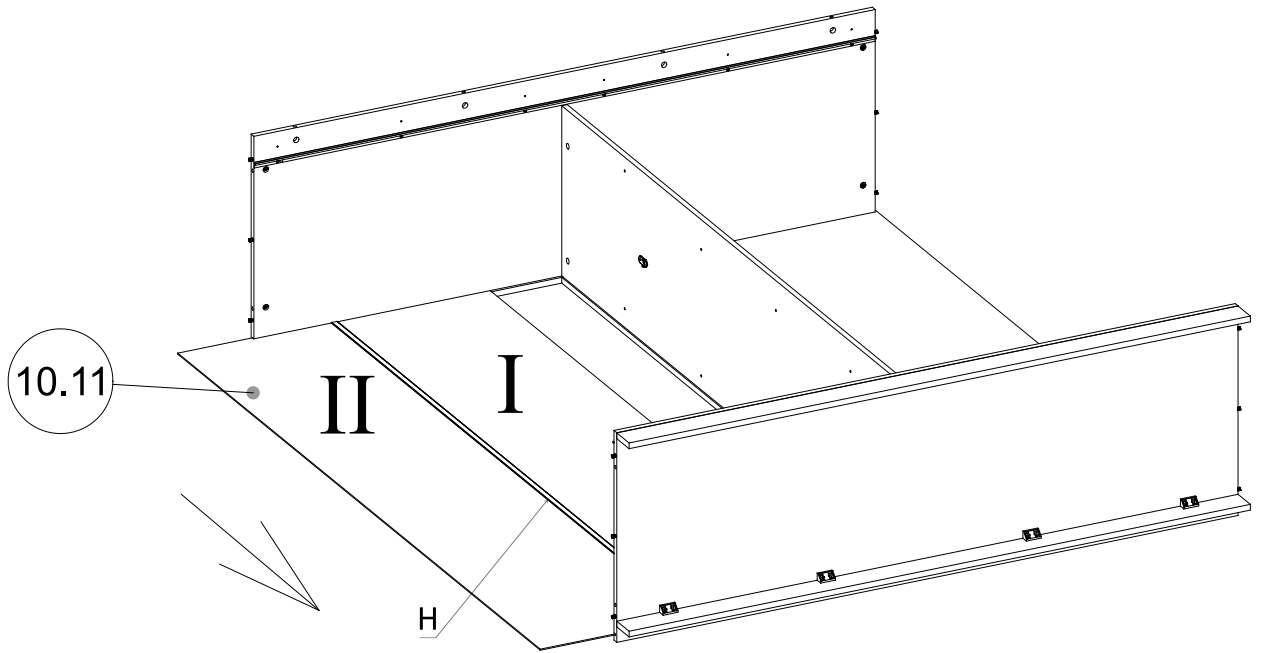
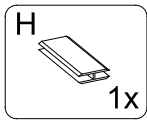

# 18

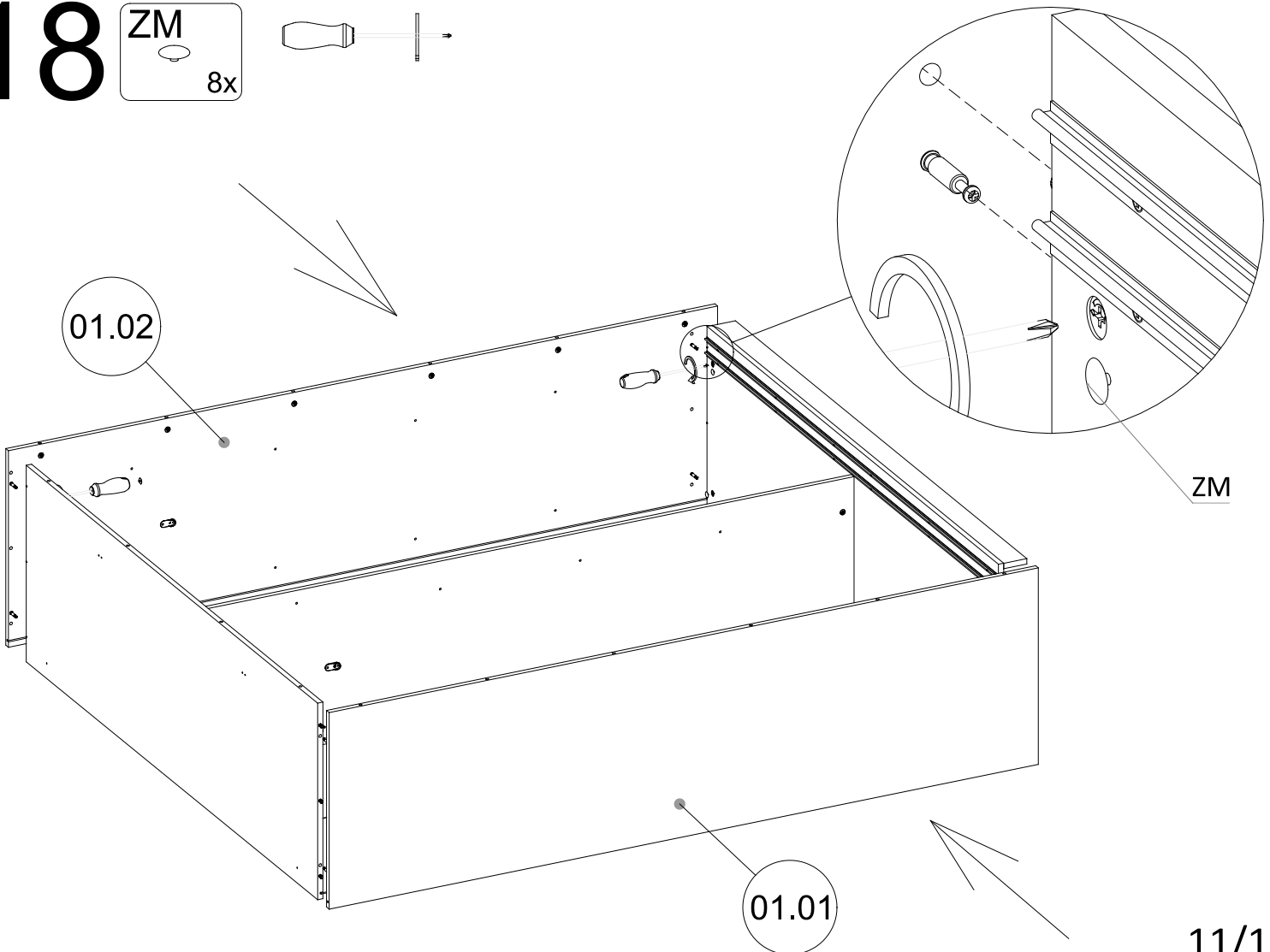
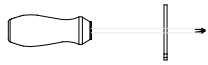
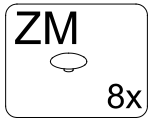

# 19

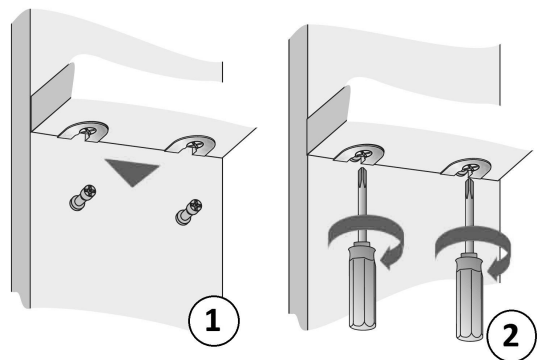
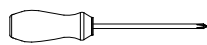
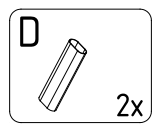

03.11

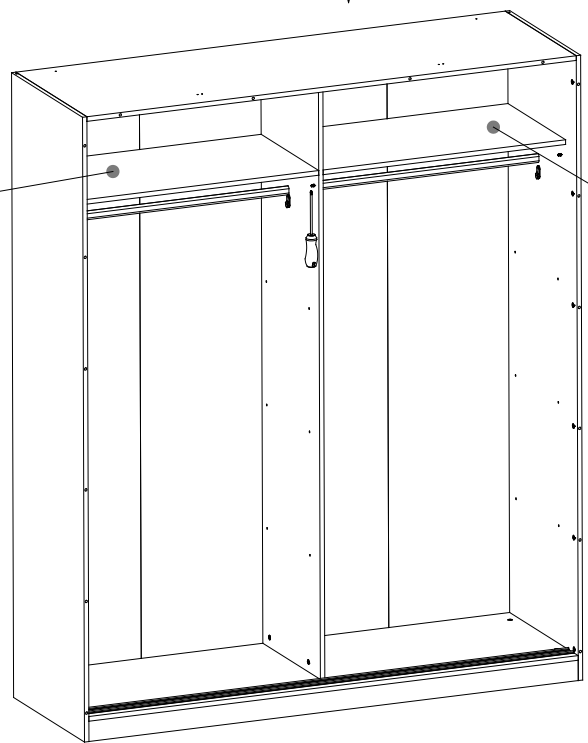

03.12

# 20

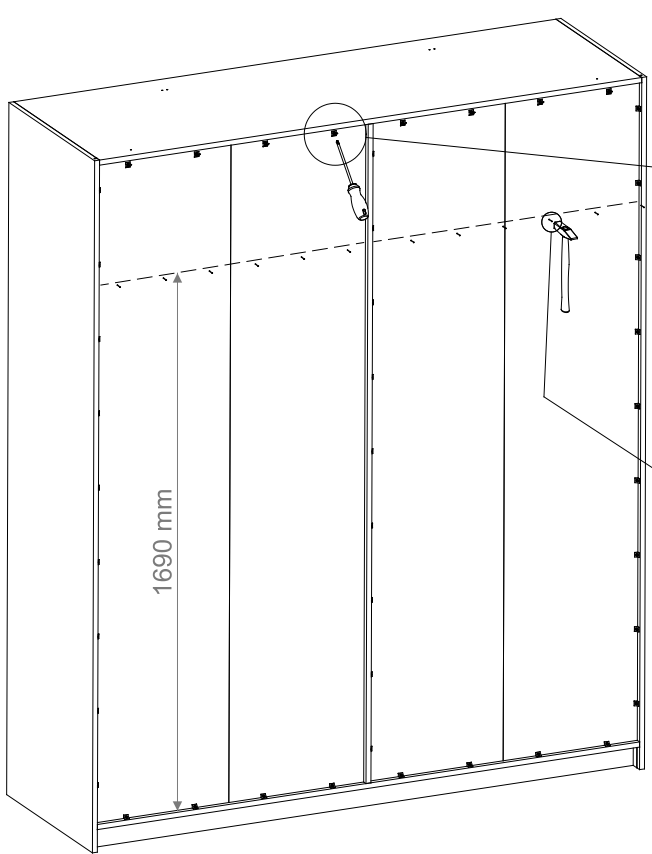
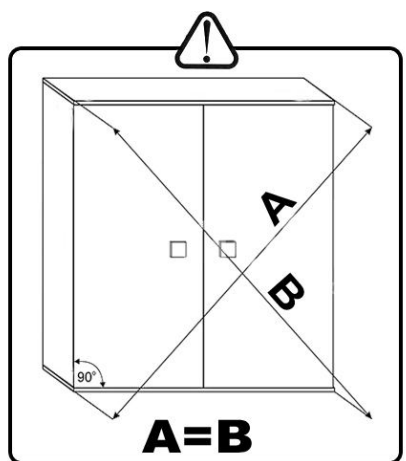
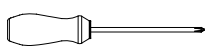
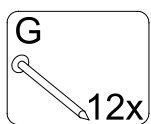
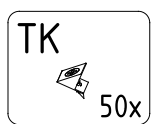

TK

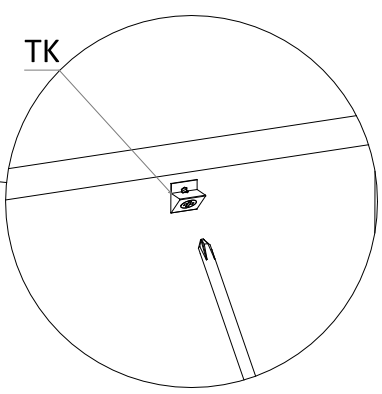

G

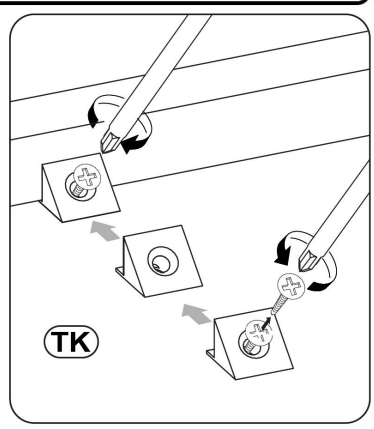
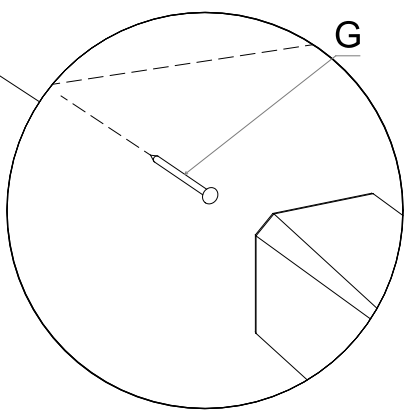

# 21

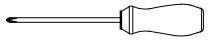
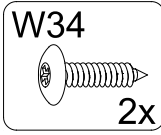
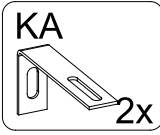

## I

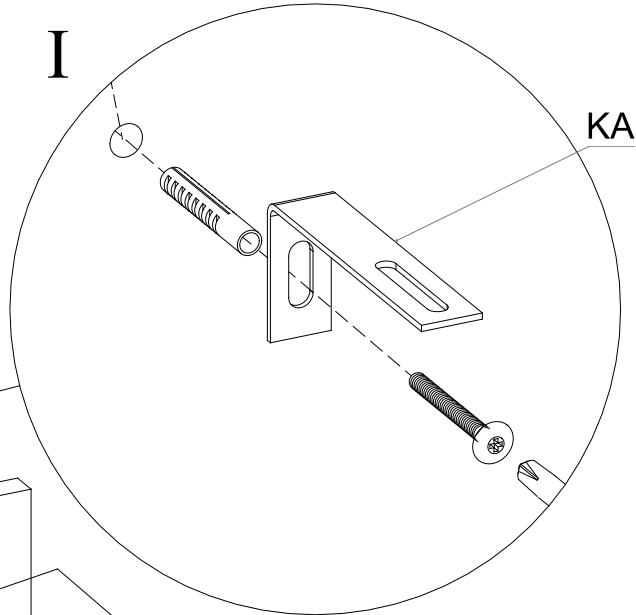

KA

## II

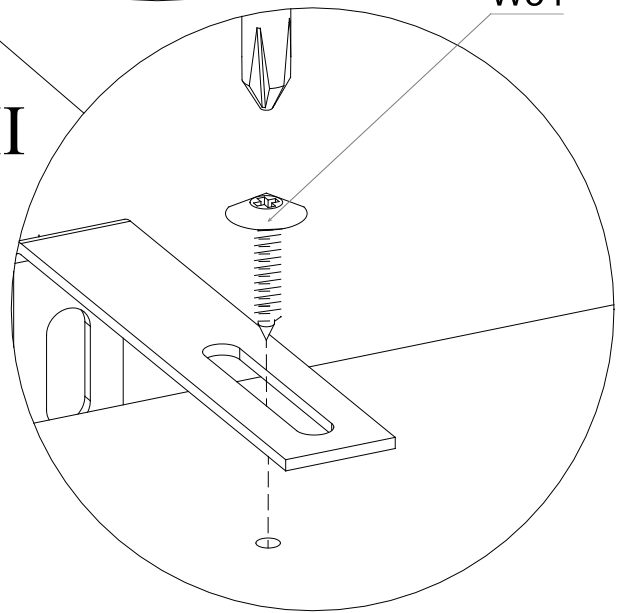

W34

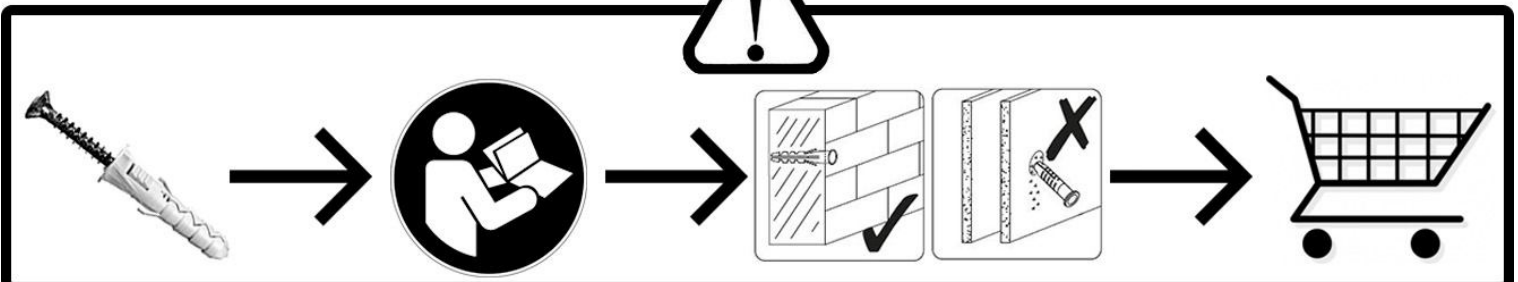
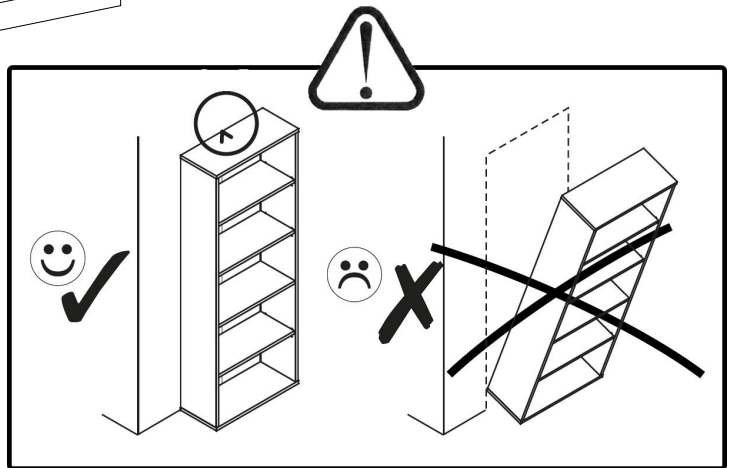
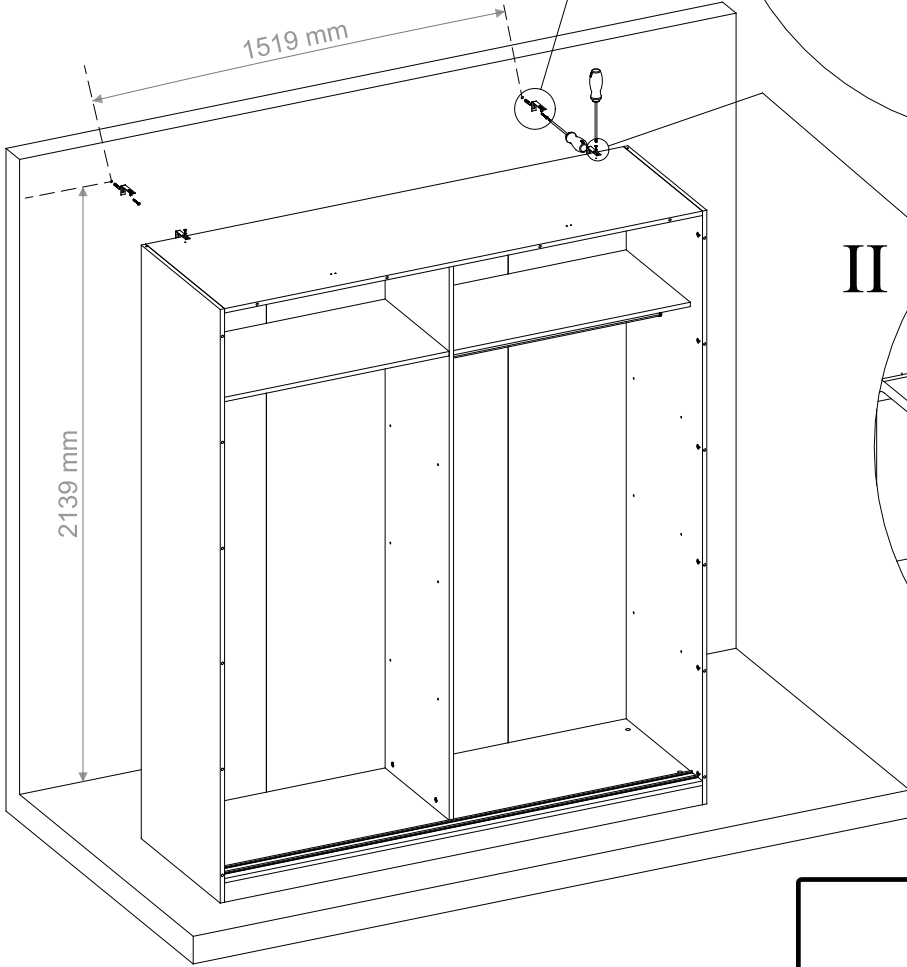

#### French

**IMPORTANT:** Pour éviter le basculement accidentel du meuble, la fixation du meuble au mur est obligatoire.

La visserie nécessaire pour la jonction mur/meuble, dépendante de la nature du mur, n'est pas fournie.

En cas de doute, consulter un spécialiste

#### English

**IMPORTANT:** To avoid the accidental tip-over of the furniture, the fixing of the furniture on the wall is mandatory.

The needed hardware for the junction wall/furniture, depending of the nature of the wall, is not provided.

If any doubt, consult a specialist.

#### Spanish

**IMPORTANTE:** Para evitar el vuelco accidental de los muebles, es obligatorio fijarlos en la pared.

El tipo de tornillos necesarios para fijar el mueble a la pared, dependen del material de la pared, no se suministran.

En caso de duda, consulte a un especialista.

#### Portuguese

**IMPORTANTE:** Para evitar a queda accidental de móveis, é obrigatório fixá-los na parede.

O tipo de parafusos para a fixação de mobiliário na parede, depende do material de parede e não são fornecidos.

Em caso de dúvida, consulte um especialista.

#### Italian

**IMPORTANTE:** Per evitare il ribaltamento accidentale del mobile è obbligatorio il fissaggio a muro.

I tasselli necessari per il collegamento mobile/muro, dipendenti dal tipo di muro, non sono provvisti.

Consultare uno specialista in caso di dubbi

#### Croatian

**VAŽNO:** Kako bi se izbjeglo slučajno prevrtanje, namještaj je potrebno pričvrstiti na (uza) zid.

Različite vrste zidova zahtijevaju upotrebu različitih vrsta vijaka i tipli. Uvijek koristiti one koji su prikladni za vrstu zidova u domu. Vijci i tiplje prodaju se zasebno.

U slučaju bilo kakvih sumnji, obratite se stručnjaku.

#### German

**WICHTIG :** Um ein versehentliches Kippen des Möbels zu vermeiden, ist die Befestigung an der Wand zwingend vorgeschrieben.

Die benötigten Schrauben zur Wandbefestigung, welche von der Beschaffenheit der Mauer abhängen, sind nicht in der Lieferung enthalten.

Wenden Sie sich bitte bei Zweifel an einen Spezialisten.

# 22

03.11

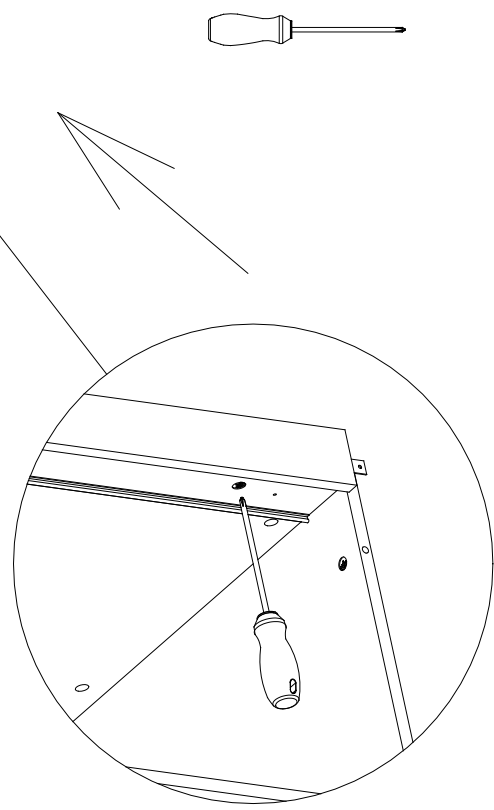
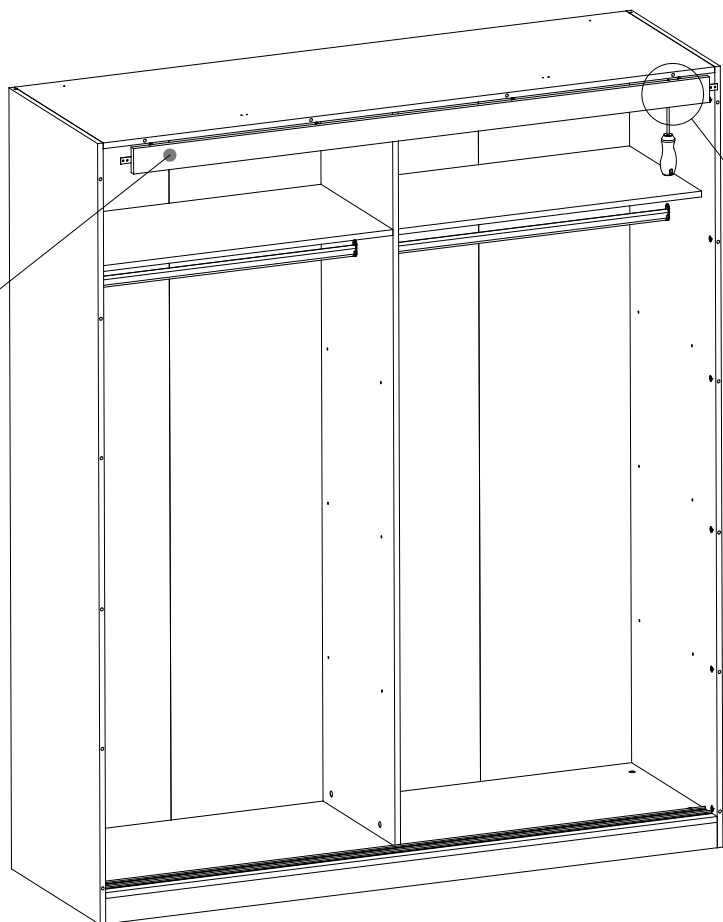

# 23

- LL 1x
- W14 7x
- HL 1x

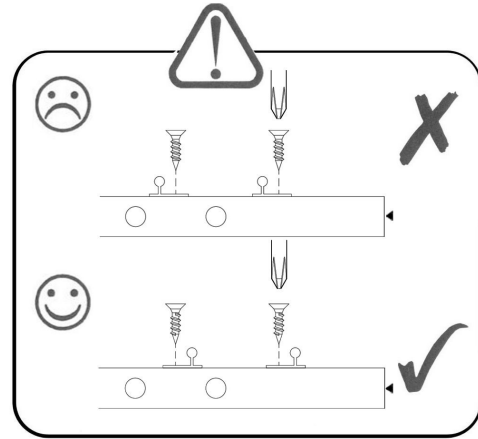
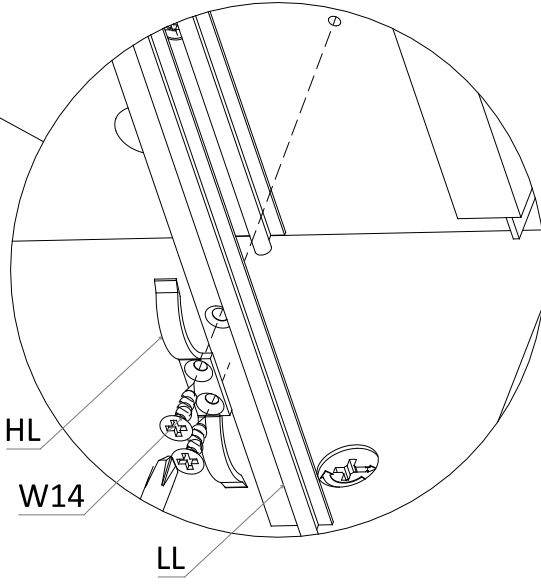
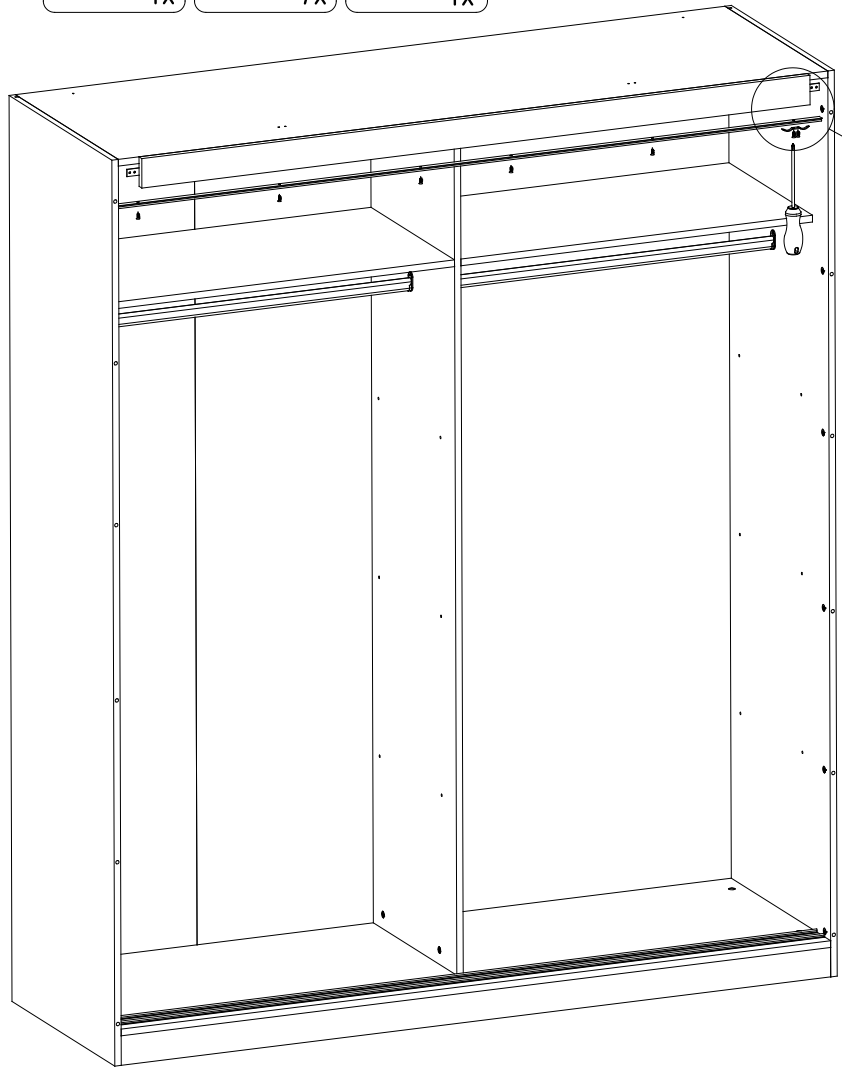
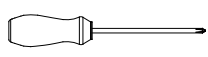

# 24

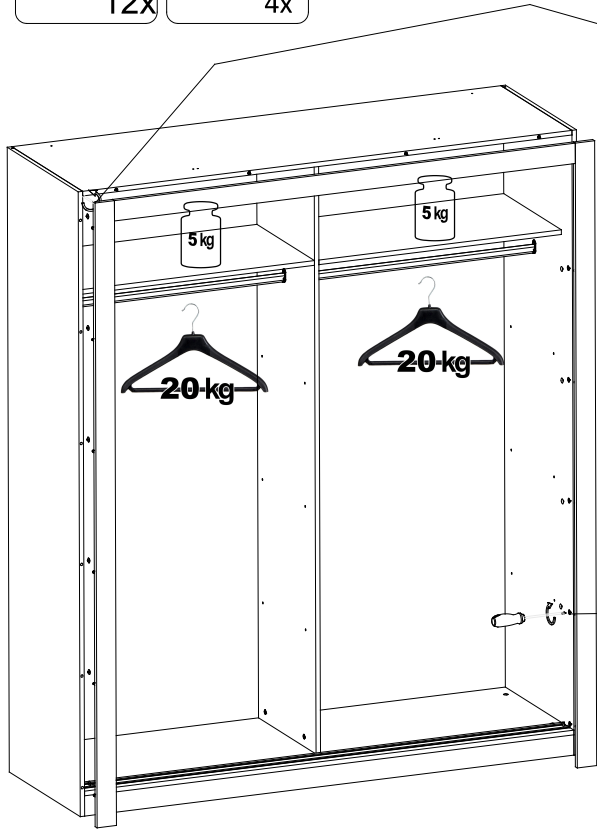
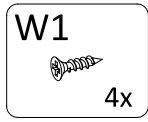
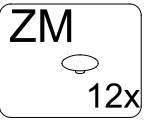

ZM

W1

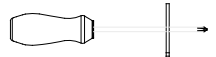

# 25

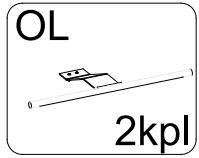
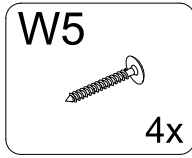
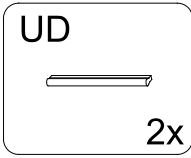

OPTIONAL LIGHT

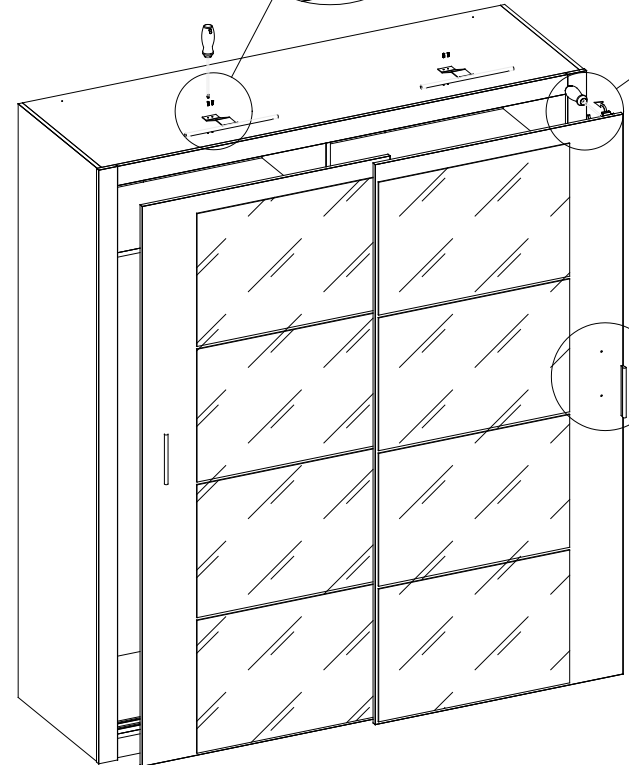
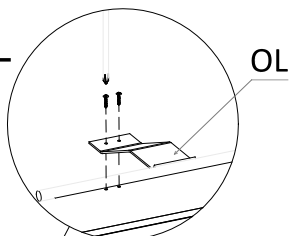

UD

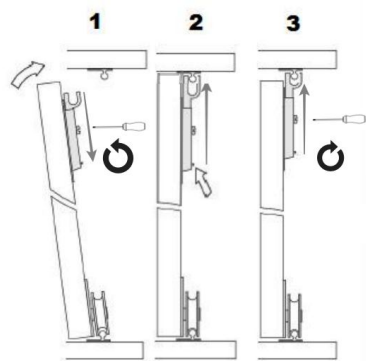
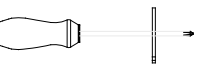

W5

FR

Conditions d' utilisation du meuble :

1. Les meubles doivent être montés et utilisés conformément aux instructions.
2. Les meubles doivent être utilisés dans des locaux secs, à l'abri d'une météo défavorable et d'une lumière directe du soleil .
3. Les meubles ne doivent pas être mis à une distance de moins de 50cm d'éléments rayonnants actifs.
4. La mise à niveau du sol est nécessaire avant le montage.
5. La notice , contenue dans les colis, définit le procédé d'assemblage des meubles, de la quantité de composants et accessoires nécessaires pour cet assemblage.
6. Les objets mouillés ne doivent pas être placés sur les surfaces du meuble.
7. Les caches du mécanisme doivent être ajustés après le montage du meuble.

Entretien et nettoyage:

1. Les surfaces stratifiées et laquées se nettoient avec un chiffon doux.
2. Les produits chimiques ou abrasifs ne devraient pas être utilisés pour le soin des surfaces.

Cher client, en cas de pièces manquantes ou défectueuses, veuillez reporter lisiblement, les détails sur la notice de montage, les scanner et nous les envoyer à l'adresse mail svp : sav@openbed.fr

CZ

Základy používání nábytku:

1. Nábytek by měl být používán k určenému účelu
2. Nábytek by měl být používán v místnostech suchých, uzavřených a chráněných před škodlivými povětrnostními vlivy a před přímým slunečním zářením.
3. Nábytek by neměl být postaven na méně než půl metru před aktivními radiátory
4. Požadované je umístění nábytku na stabilním, vyrovnaném povrchu.
5. Návod na montáž nábytku, počet součástí a příslušenství nezbytného k montáži je uveden na informačním listu, nacházejícím se v obalu určeného nábytku. V případě, že na přání zákazníka nábytek byl dodán smontovaný, návod k montáži se nepřipojuje.
6. Na povrch nábytku nepokládejte vlhké předměty.
7. Po smontování nábytku seřídít ( vyrovnat ) dveře pomocí kolejniče.

Údržba a čištění:

1. Povrchy z lamina a lakované čistit měkkým hadříkem.
2. K údržbě povrchu nepoužívejte žádné chemické látky ani hrubé hadříky.

Vážený zákazníku, v případě, že chybí některé části nebo jsou poškozené, označte je v montážních instrukcích a zašlete společně s reklamací. Pokud poškozená část bude na pevně smontována, nebude se na ní vztahovat reklamace.

DE

Regeln der Möbelbenutzung:

1. Die Möbel sollten entsprechend ihrer Bestimmung verwendet werden.
2. Die Möbel sollten in trockenen, geschlossenen und gegen den schädlichen Witterungseinfluss sowie die direkte Wirkung der Sonnenstrahlen geschützten Räumen benutzt werden.
3. Die Möbel sollen von den tätigen Heizkörpern mindestens ein halbes Meter entfernt werden.
4. Es ist erforderlich, dass der Grund, wo die Möbel stehen, gut nivelliert und stabil ist.
5. Die Art und Weise der Montage, Anzahl der Bauteile und die Ausstattung, die für die Montage unentbehrlich ist, bestimmt die Infokarte, die sich in der Verpackung des jeweiligen Möbelstückes befindet. Es sei denn, die Möbel wurden nach dem Wunsch des Kunden im zusammengebauten Zustand geliefert. In einem solchen Fall werden die Montageanweisungen nicht hinzugefügt.
6. Auf der Oberfläche der Möbel darf man keine feuchten Gegenstände stellen.
7. Nach dem Zusammenbauen der Möbel sollte man die Tür an den Führungen richten.

Wartung und Sauberhaltung:

1. Flächen aus Laminat und lackierte Oberflächen sind mit einem weichen Tuch zu reinigen.
2. Zur Pflege der Oberfläche sollten keine chemischen Mitteln oder borstigen Wischtücher verwendet werden.

Sehr geehrter Kunde, sollte ein Bauteil fehlen oder geschädigt werden, kennzeichnen Sie dies bitte auf der Montageanweisung und zusammen mit dem Beschwerdebrief senden. Sollte das geschädigte Teil fest angebaut werden, wird die Beanstandung nicht anerkannt.

EN

Terms of use furniture:

1. Furniture should be used for their intended purpose.
2. Furniture should be used in dry, closed rooms, protected from an adverse weather and a direct sunlight.
3. Furniture should not be set at a distance of less than half a meter of active radiators.
4. The equal leveling is required and the need to set furniture on the stable base.
5. The information card, contained in the packaging of the given type of furniture, defines the assembling method of furniture, quantity of components and accessories necessary for assembly. Except when furniture were delivered assembled according to the customer wish. Assembly instructions are not attached to furniture in this case.
6. Wet objects should not be placed on surfaces of furniture.
7. Doors on tracks should be adjusted after assembling furniture.

Maintenance and cleaning:

1. Surfaces made of the laminate and lacquered surfaces clean with a soft cloth.
2. Any chemicals or rough rubbers should not be used for the surfaces care.

Dear customer, if anything part is missing or damaged, mark it on the assembly instruction and sent together with the claim, please. If the damaged item is permanently mounted, than the complaint will not be considered.

SK

Základy používania nábytku:

1. Nábytok používajte k určenému účelu.
2. Nábytok používajte v suchej, uzatvorenej a chránenej pred škodlivými poveternostnými vplyvmi miestnosti , chráňte pred priamym slnečným žiarením.
3. Nábytok by nemal byť postavený na menej než pol metra pred aktívnymi radiátormi
4. Nábytok postavte na stabilný, vyrovnaný povrch.
5. Návod na montáž nábytku, počet súčastí a príslušenstva nevyhnutného k montáži, je uvedený na informačnom liste nachádzajúcom sa v obale určeného nábytku. V prípade, že na pranie zákazníka bol nábytok dodaný zmontovaný, nebude návod súčasťou balenia.
6. Na povrch nábytku, nepokladajte vlhké predmety.
7. Po zmontovaní nábytku nastavte dveře pomocou kolejniče.

Údržba a čistenie:

1. Povrchy z lamina a lakované čistit mäkkou handričkou.
2. Pre údržbu povrchu nepoužívajte žiadne chemické látky ani hrubé handričky.

Vážený zákazník, v prípade, že chýbajú niektoré časti, alebo sú poškodené, označte ich v montážnych inštrukciách a pošlite spoločne s reklamáciou. Pokiaľ poškodená časť bude napevno zmontovaná, nebude sa ňu reklamácia vztahovať.

RU

Правила ухода за мебелью:

1. Мебелью необходимо использовать в соответствии с ее функциональным назначением.
2. Мебель должна эксплуатироваться в сухих, закрытых и защищенных от воздействия атмосферных условий и прямых солнечных лучей помещениях.
3. Мебели нельзя устанавливать ближе 50 см от отопительных приборов.
4. Требуется установка мебели по уровню на стабильной поверхности.
5. Способ монтажа мебели, количество элементов необходимых для монтажа определяет инструкция находящаяся в упаковке данного типа мебели. В случае, если мебель по желанию Клиента была поставлена собранной, инструкция монтажа не прилагается.
6. Нельзя ставить на мебель влажные предметы.
7. После монтажа мебели необходимо отрегулировать дверь на петлях.

Рекомендации по уходу и очистке:

1. Поверхности из ламината и покрытые лаком очищать мягкой тканью.
2. Для ухода за поверхностью не использовать никаких химических средств или шероховатых тряпок.

Уважаемы Клиент, в случае если не хватает какого-нибудь элемента или он поврежден, просим обозначить его на инструкции монтажа и отправить нам вместе с претензией. Если поврежденный элемент будет установлен – претензия не будет признана.