

# ASSEMBLY INSTRUCTIONS

MODEL #

FM79011-K-HB-FB-R

Questions?

GIVE US A CALL: 1-888-980-5122  
MON-FRI 8:30AM - 5:30PM (PT)

## TOOLS REQUIRED

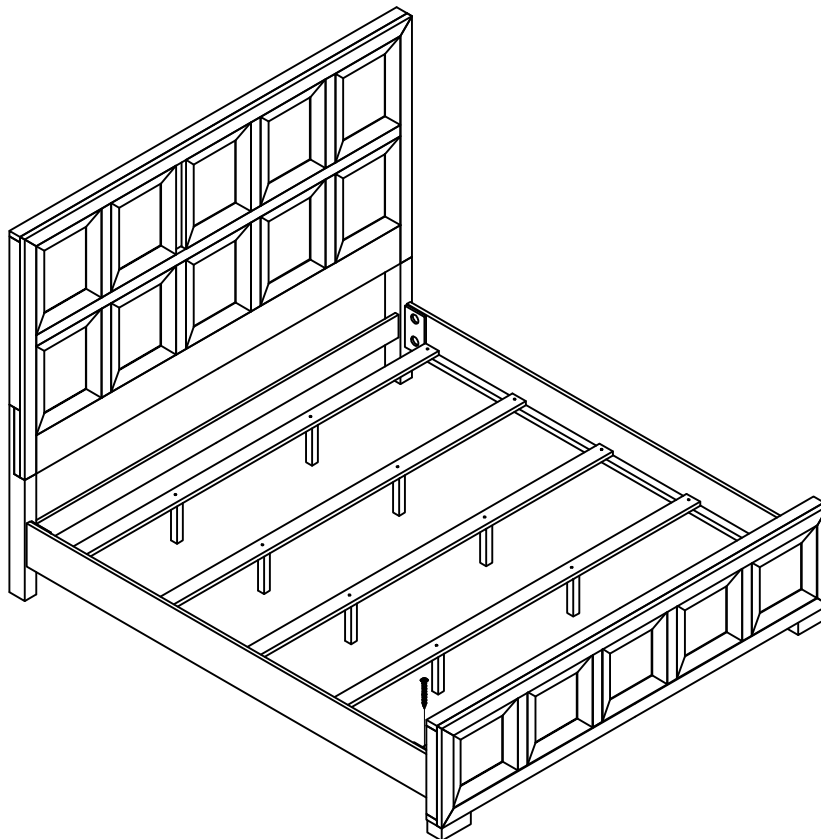

Screwdriver  
(Not included)

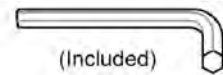

(Included)  
Allen Wrench



2 - People

## ASSEMBLY RATING



EASY —————> DIFFICULT

The Assembly Rating is a 5-point system showing the level of effort needed to assemble a specific product.



Thank you for your purchase!

We hope you enjoy this new addition to your home for many years to come.

Our commitment to providing quality products does not simply end when you purchase our product. We fully stand behind our products from start to finish. Our customer service department is available Monday – Friday 8:30 AM – 5:30 PM Pacific Time and can help with assembly questions as well as, if necessary, replacing damaged or missing parts. To help expedite our service, please have these assembly instructions readily available, along with your order receipt.



**Consumer Hotline**  
Toll-Free 1-888-980-5122



**Monday to Friday**  
8:30AM- 5:30PM (PT)



**WEBSITE**  
[www.foagroup.com](http://www.foagroup.com)



**E-MAIL**  
[cs.ec@foagroup.com](mailto:cs.ec@foagroup.com)



foagroup



FurnitureOfAmerica



## CHECK BEFORE STARTING



### Are you missing anything?

Double-check all parts, hardware and accessories listed are all accounted for.



### Check out our Quick Tips!

We recommend reviewing the pre-assembly handouts. Even experts need a refresher now and then!



### Should we send any replacements?

Are there any irregularities or flaws in the parts? We can send replacements!



### Prep Time!

Please review the assembly instructions and all diagrams prior to assembling.

# PRE ASSEMBLY INTRODUCTION

We understand building ready-to-assemble furniture can be a challenging experience for some. To help avoid confusion, we have provided some helpful tips that may speed up the process.



## Teamwork

ALWAYS have at least two people to help with transporting and assembling the product to avoid potential injury and/or damage.



## Suitable Location

Assembling near the area of the intended location is highly recommended.



## Sufficient Space

Make sure you have enough space to move around during the assembly.



## Avoid Scratches

Use cardboard, blankets or a carpeted area while assembling furniture to prevent to prevent scratches and damages.



## Flat Surface

Make sure the furniture rests on a flat and level surface with each leg evenly touching the floor.

# ASSEMBLY AND CARE ADVICE



**FAILURE TO FOLLOW THE GUIDELINES BELOW MAY RESULT IN INJURY AND/OR PROPERTY DAMAGE.**



Position each part correctly and insert screws or bolts into their respective holes.



Turn clockwise to tighten and only tighten when step is completed or when instructed to do so.



Use the appropriate hand tools or power tools for assembly. Select steps, such as tightening screws and/or bolts, may require hand tools to avoid causing damage during assembly.



Save the instructions and store any supplied tools for later maintenance.



After two weeks, check and tighten any loose hardware and repeat again every six months thereafter.

**IT IS THE USER'S RESPONSIBILITY TO MAINTAIN THE FURNITURE. THE HARDWARE MAY LOOSEN OVER TIME AND MAY CAUSE THE FURNITURE TO BE WOBBLY AND UNABLE TO SUPPORT ITS INTENDED WEIGHT CAPACITY. THIS MAY LEAD TO COLLAPSE AND MAY CAUSE SERIOUS INJURY.**

# KING BED

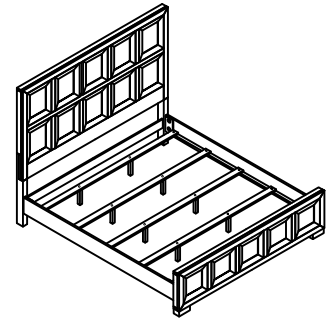

## PARTS

1

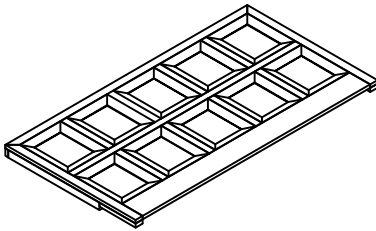

HEADBOARD  
1pc

2

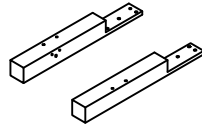

HEADBOARD LEG L/R  
2pcs

3

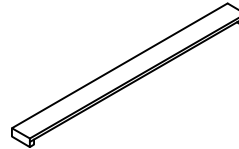

STRETCHER  
1pc

4

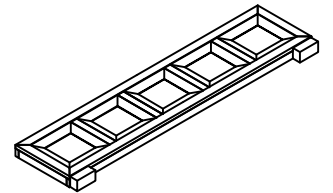

FOOTBOARD  
1pc

5



SLATS  
5pcs

6

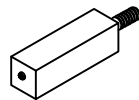

SUPPORT SLATS  
10pcs

7

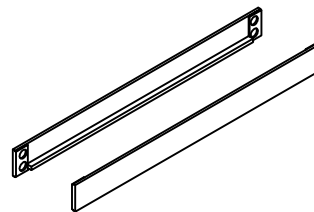

SIDE RAILS  
2pcs

# HARDWARE

## 1 .ASSEMBLY HEABOARD

A



ALLEN WRENCH  
1pc

B



BOLT  $\text{\O}5/16"$ x 2"  
8pcs

C



LOCK WASHER  $\text{\O} 5/16$   
8pcs

D



LOCK WASHER  $\text{\O} 5/16$  x 19mm  
8pcs

## 2 .ASSEMBLY SIDE RAILS

E

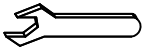

OPEN WRENCH  
1pc

F



NUTS  $\text{\O}5/16"$   
8pcs

G



CURVED WASHER  
8pcs

H



BOLT  $\text{\O}5/16"$ x 3"  
8pcs

I







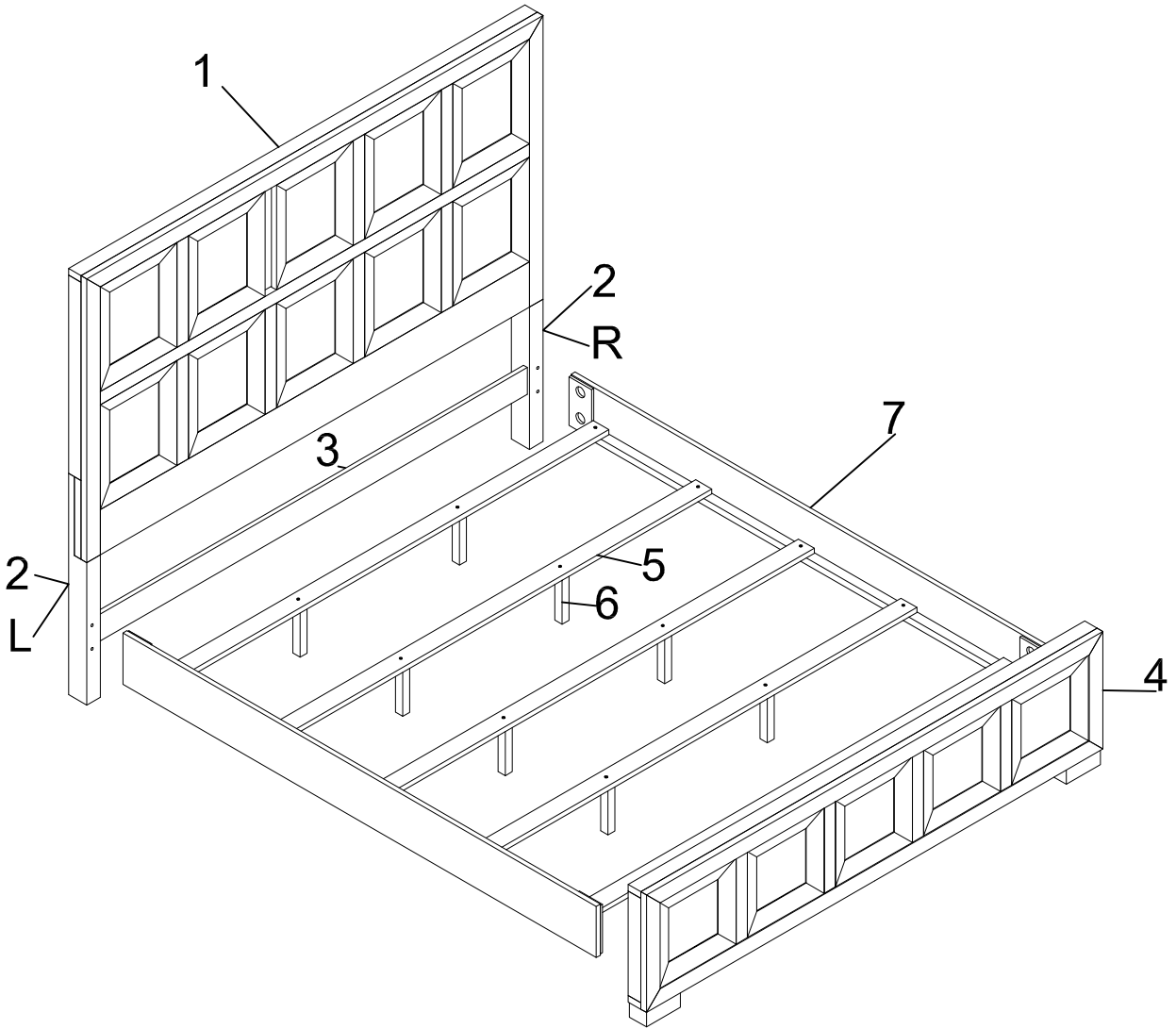



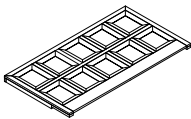

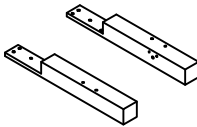

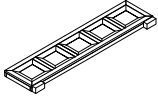

WOOD SCREWS  $\text{\O}8$ \*1 1/4"  
10pcs

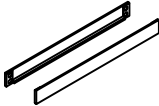
# EXPLODED VIEW



# FM79011-K-HB-FB-R is packed 3 case

Carton	Disignation	Part		Hardware
<b>FM79011-K-HB</b>	Headboard	# 1		 # A x 1pc  # B x 8pcs
	Headboard legs L/R	# 2		 # C x 8pcs  # D x 8pcs
	Stretcher	# 3		
<b>FM79011-K-FB</b>	Footboard	# 4		
	Slats	# 5		
	Support Slats	# 6		
<b>FM79011-K-R</b>	Side rails	# 7		 #E x 1pc  # F x 8pcs  #G x 8pcs  # H x 8pcs  # I x 10pcs

# ASSEMBLY INSTRUCTIONS

- 1** Part #1 x 1pc  
Part #2 x 2pcs  
Hardware #A x 1pc  
Hardware #B x 6pcs  
Hardware #C x 6pcs  
Hardware #D x 6pcs

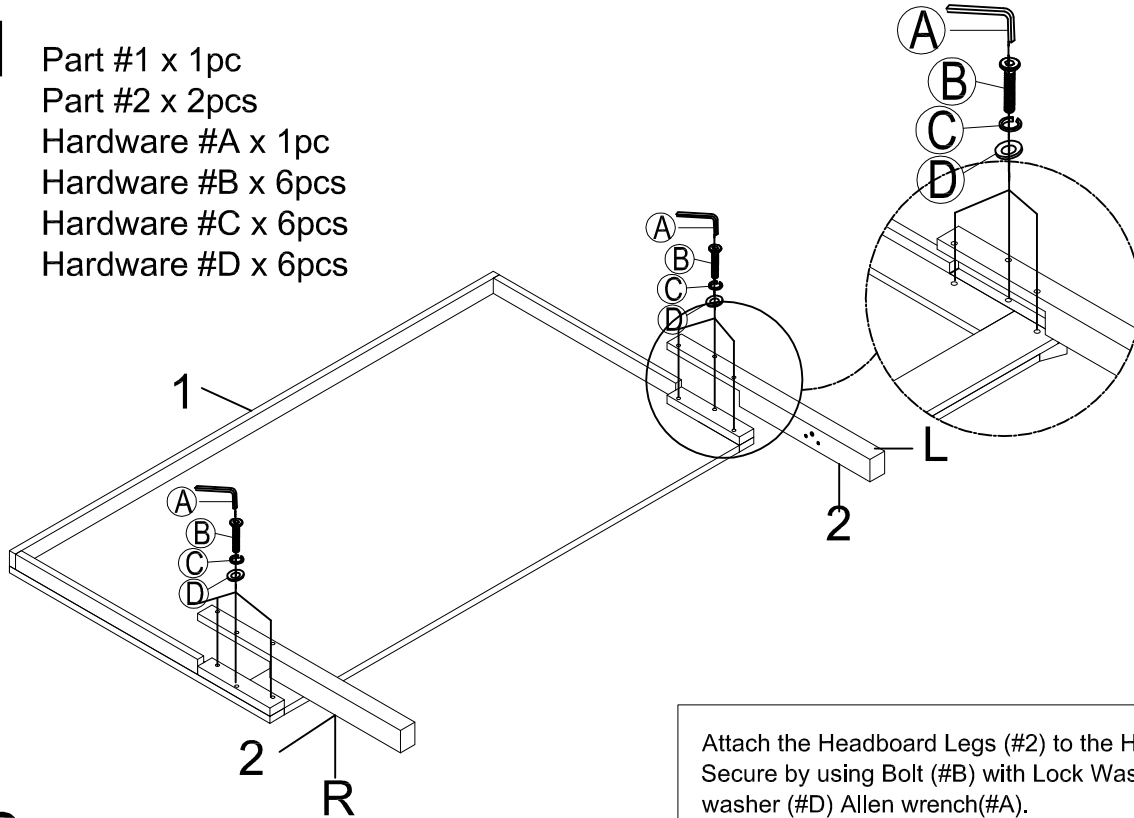

Attach the Headboard Legs (#2) to the Headboard (#1). Secure by using Bolt (#B) with Lock Washer (#C) and Flat washer (#D) Allen wrench(#A).

- 2** Part #1 x 1pc  
Part #2 x 2pcs  
Part #3 x 1pc  
Hardware #A x 1pc  
Hardware #B x 2pcs  
Hardware #C x 2pcs  
Hardware #D x 2pcs

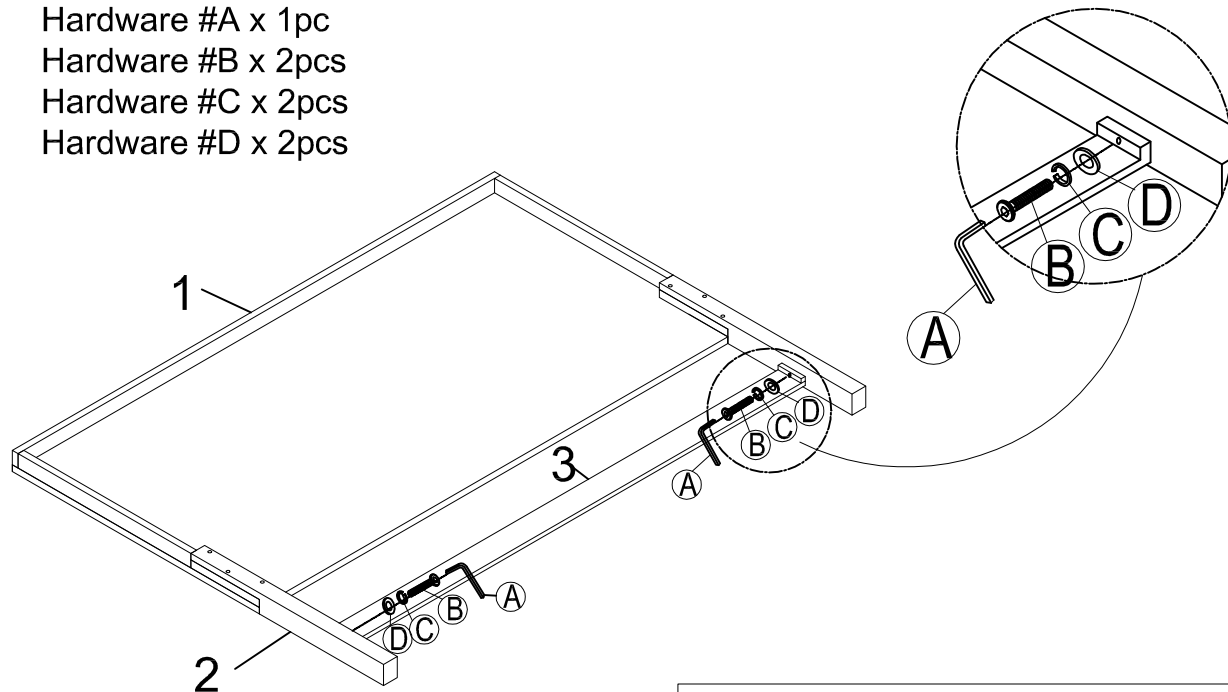

Attach the Stretcher (#3) to the Legs (#2). Secure by using Bolt (#B) with Lock Washer (#C) and Flat washer (#D) Allen wrench(#A).

# ASSEMBLY INSTRUCTIONS

## 3

Headboard x 1pc  
Footboard x 1pc  
Part #7 x 2pcs  
Hardware #E x 1pc  
Hardware #F x 8pcs  
Hardware #G x 8pcs  
Hardware #H x 8pcs

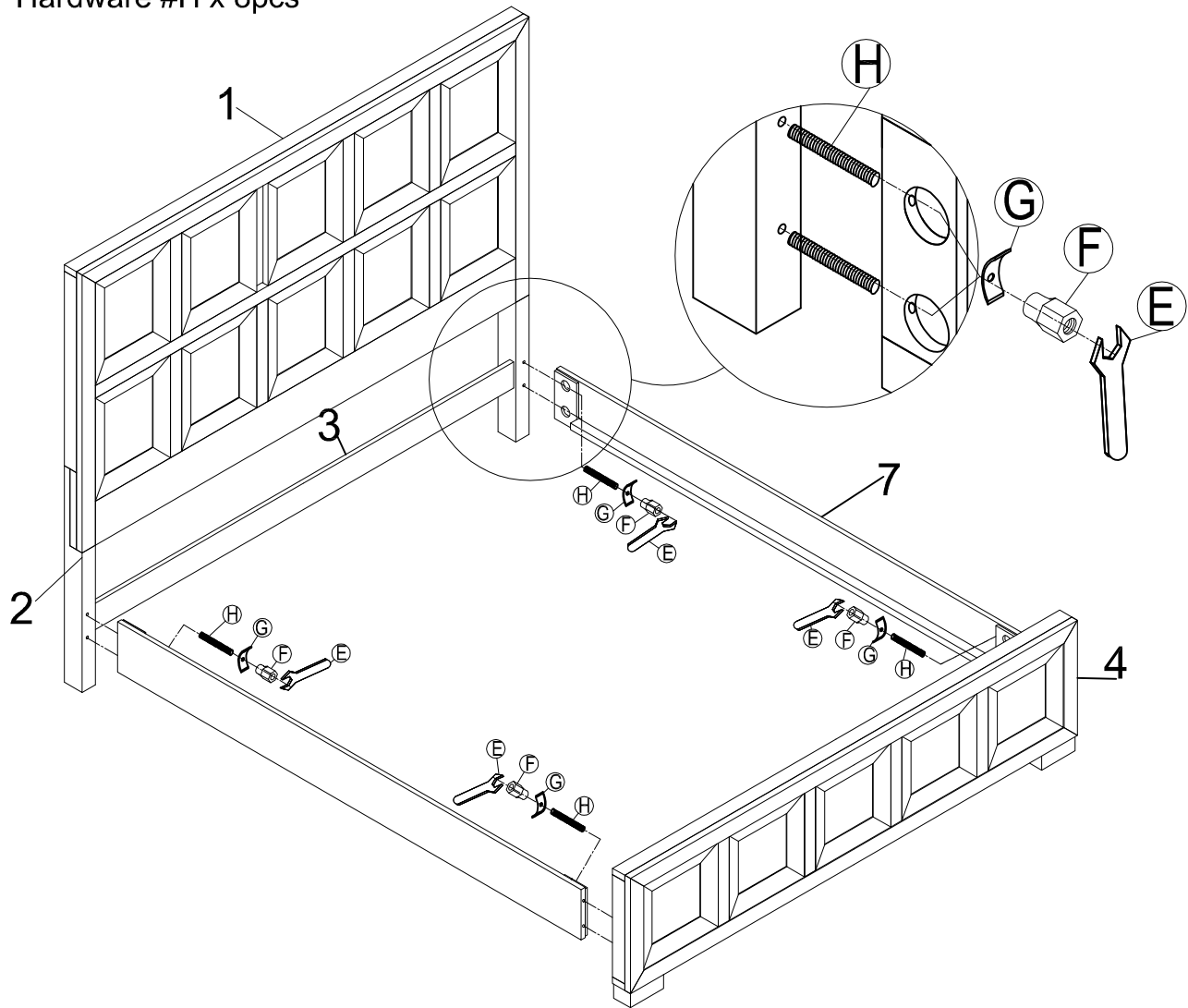

Screw the Bolt (H) into HB & FB.  
Align the bolts with the holes in the end of side rails and attach the side rails to HB & FB using half moon washers (G) and nuts (F). Then use a hex wrench (E) to tighten all the nuts.

# ASSEMBLY INSTRUCTIONS

- 4** Headboard x 1pc  
Footboard x 1pc  
Part #5 x 5pcs  
Part #6 x 10pcs  
Part #7 x 2pcs  
Hardware # 1 x 10pcs

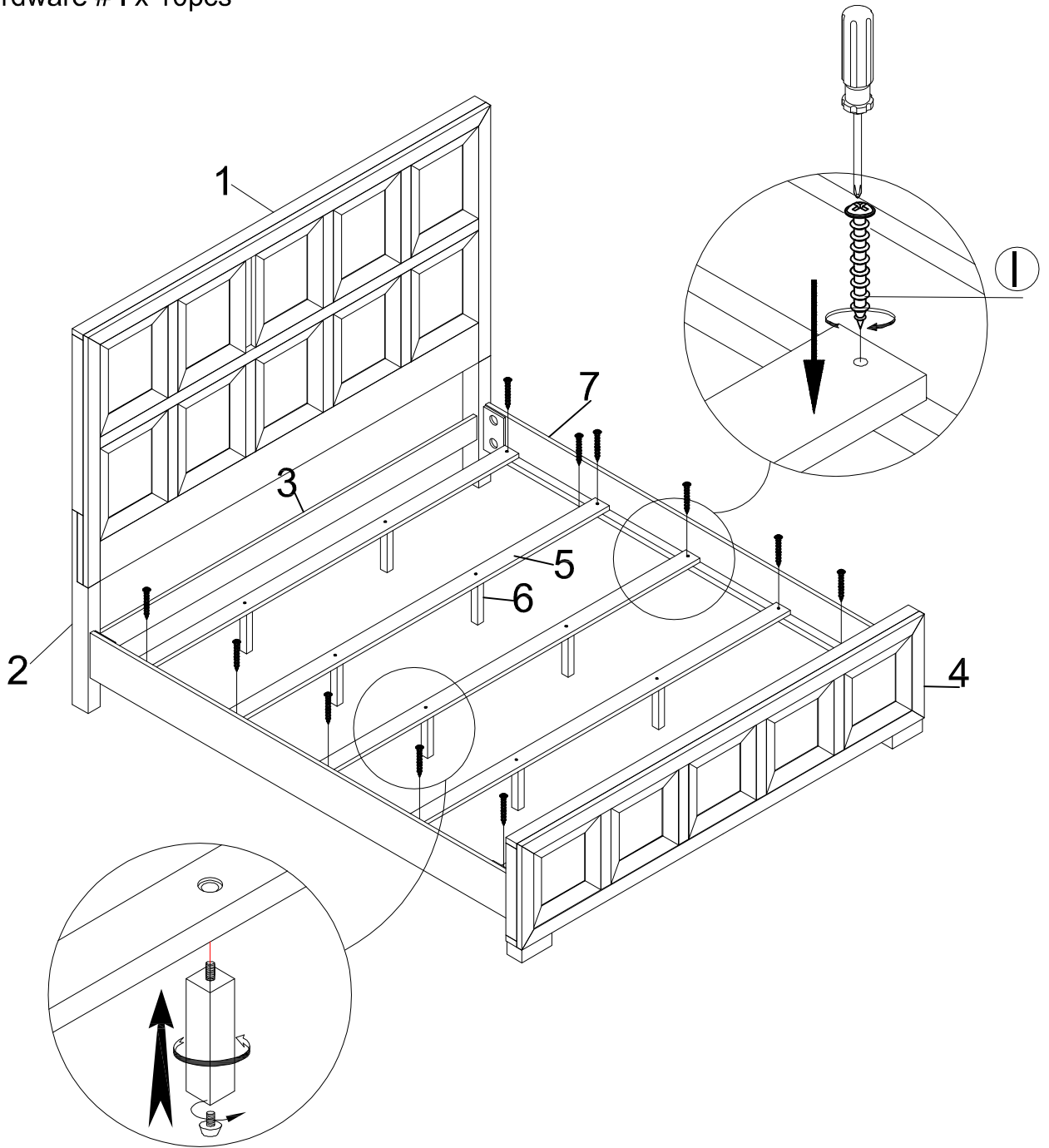

# ASSEMBLY INSTRUCTIONS

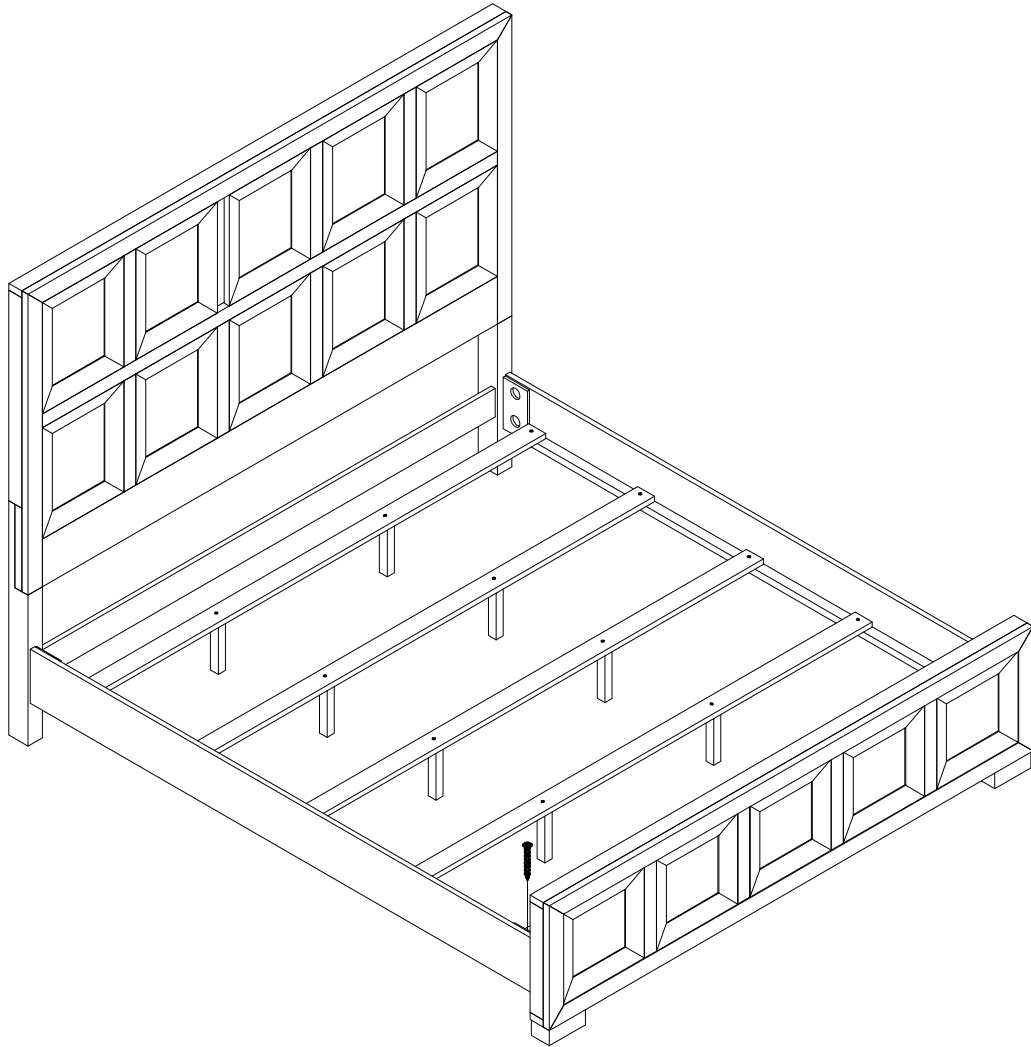

## ASSEMBLY COMPLETED



Please ensure the furniture rests on an even and flat surface. If the product wobbles or feels loose, double-check all bolts and/or screws are properly tightened and secured.

### ✓ Keep this handy!

Please retain this instruction manual and any order-related information for future reference.

### ✓ Lift, don't drag!

To avoid damage to product joints, always LIFT the product when transporting or adjusting the placement.

# ASSEMBLY INSTRUCTIONS

MODEL #

**FM79011-N**

Questions?

GIVE US A CALL: 1-888-980-5122  
MON-FRI 8:30AM - 5:30PM (PT)

## TOOLS REQUIRED



Screwdriver  
( Not included)

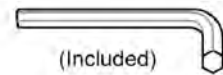

(Included)  
Allen Wrench



2 - People

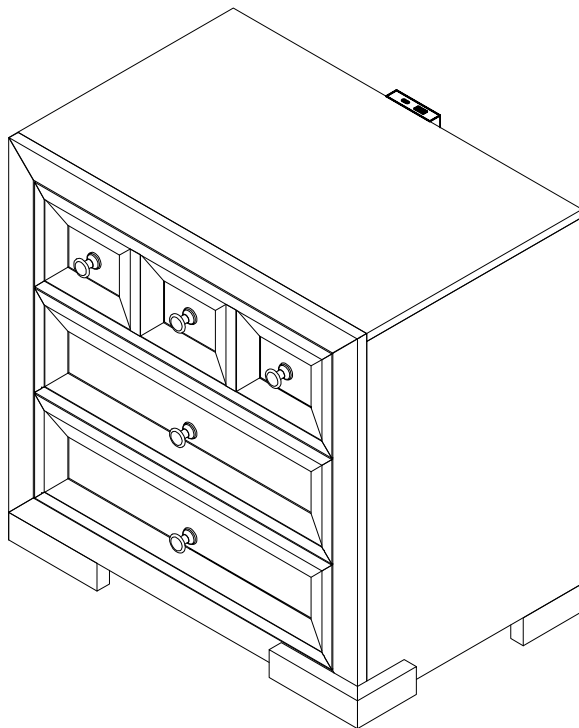

## ASSEMBLY RATING



EASY —————> DIFFICULT

The Assembly Rating is a 5-point system showing the level of effort needed to assemble a specific product.



Thank you for your purchase!

We hope you enjoy this new addition to your home for many years to come.

Our commitment to providing quality products does not simply end when you purchase our product. We fully stand behind our products from start to finish. Our customer service department is available Monday – Friday 8:30 AM – 5:30 PM Pacific Time and can help with assembly questions as well as, if necessary, replacing damaged or missing parts. To help expedite our service, please have these assembly instructions readily available, along with your order receipt.



**Consumer Hotline**  
Toll-Free 1-888-980-5122



**Monday to Friday**  
8:30AM- 5:30PM (PT)



**WEBSITE**  
[www.foagroup.com](http://www.foagroup.com)



**E-MAIL**  
[cs.ec@foagroup.com](mailto:cs.ec@foagroup.com)



foagroup



FurnitureOfAmerica



## CHECK BEFORE STARTING



### Are you missing anything?

Double-check all parts, hardware and accessories listed are all accounted for.



### Check out our Quick Tips!

We recommend reviewing the pre-assembly handouts. Even experts need a refresher now and then!



### Should we send any replacements?

Are there any irregularities or flaws in the parts? We can send replacements!



### Prep Time!

Please review the assembly instructions and all diagrams prior to assembling.

# PRE ASSEMBLY INTRODUCTION

We understand building ready-to-assemble furniture can be a challenging experience for some. To help avoid confusion, we have provided some helpful tips that may speed up the process.



## Teamwork

ALWAYS have at least two people to help with transporting and assembling the product to avoid potential injury and/or damage.



## Suitable Location

Assembling near the area of the intended location is highly recommended.



## Sufficient Space

Make sure you have enough space to move around during the assembly.



## Avoid Scratches

Use cardboard, blankets or a carpeted area while assembling furniture to prevent to prevent scratches and damages.



## Flat Surface

Make sure the furniture rests on a flat and level surface with each leg evenly touching the floor.

# ASSEMBLY AND CARE ADVICE



**FAILURE TO FOLLOW THE GUIDELINES BELOW MAY RESULT IN INJURY AND/OR PROPERTY DAMAGE.**



Position each part correctly and insert screws or bolts into their respective holes.



Turn clockwise to tighten and only tighten when step is completed or when instructed to do so.



Use the appropriate hand tools or power tools for assembly. Select steps, such as tightening screws and/or bolts, may require hand tools to avoid causing damage during assembly.



Save the instructions and store any supplied tools for later maintenance.



After two weeks, check and tighten any loose hardware and repeat again every six months thereafter.

**IT IS THE USER'S RESPONSIBILITY TO MAINTAIN THE FURNITURE. THE HARDWARE MAY LOOSEN OVER TIME AND MAY CAUSE THE FURNITURE TO BE WOBBLY AND UNABLE TO SUPPORT ITS INTENDED WEIGHT CAPACITY. THIS MAY LEAD TO COLLAPSE AND MAY CAUSE SERIOUS INJURY.**

# NIGHTSTAND w/ USB A-C

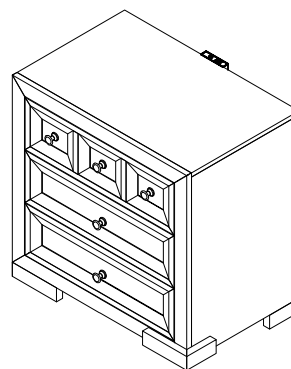
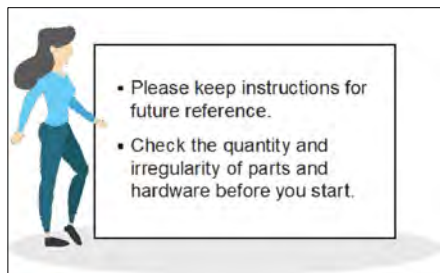

## PARTS

1

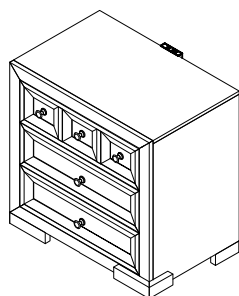

NIGHTSTAND  
1pc

## HARDWARE

A

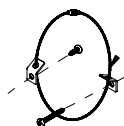

ANTI TIP KIT  
1pc

# ASSEMBLY INSTRUCTIONS

Hardware #A x 1pc

Use anti-tip kit to secure Nightstand to the wall.

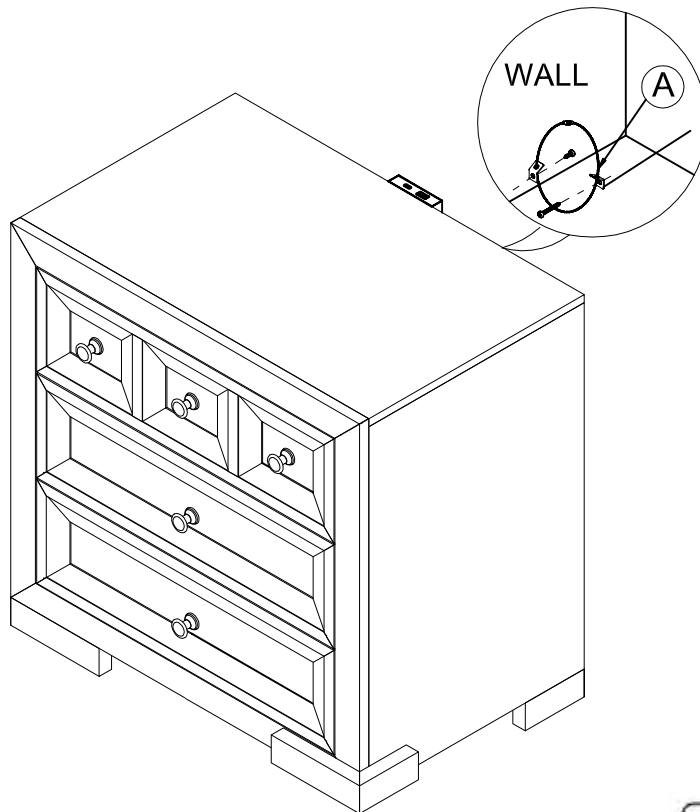

## ASSEMBLY COMPLETED



Please ensure the furniture rests on an even and flat surface. If the product wobbles or feels loose, double-check all bolts and/or screws are properly tightened and secured.



### Keep this handy!

Please retain this instruction manual and any order-related information for future reference.



### Lift, don't drag!

To avoid damage to product please always LIFT the product when transporting or adjusting the placement.

# ASSEMBLY INSTRUCTIONS

## Wall Mounting and Fixing



### EXPANSION WALL ANCHOR

Our provided expansion wall anchors are only suitable for masonry walls, such as drywall, plaster or concrete, and are best for holding lightweight items or for anti-tip prevention. If you are unsure of the correct wall anchor to use with the product, please request professional guidance. Liability for product damage or failures due to using the incorrect anchors will fall on the installer.



### CHECK BEFORE PROCEEDING

Prior to drilling or hammering, please check for wires or pipes. We recommend using a stud finder to locate a stud, which will offer more appropriate resistance and hold more weight.

## QUICK TIPS

1. If unsure of the proper size, always choose a larger screw and wall anchor.

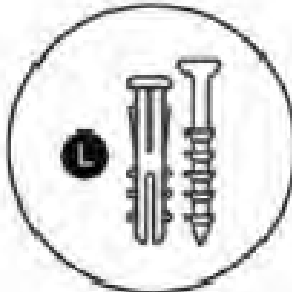

2. Match the drill bit to the wall anchor and hole size.

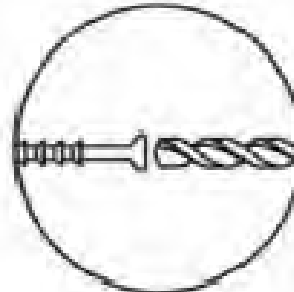

3. Only drill horizontally. Do not force the drill or enlarge the hole for the wall anchor.

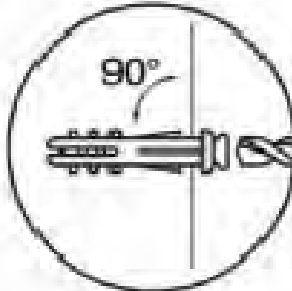

4. Take extra care when drilling into high walls or ceramic tiles. Wall anchors should be a tight fit for the hole. Never use wall anchors in ceilings.

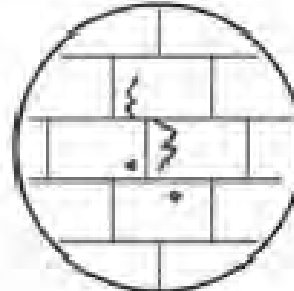

### MAINTENANCE



Tighten Check

We recommend a yearly check to see if the wall anchor or screw has loosened. If so, please remove the existing wall anchor and screw, and use a new anchor.