

90Mins

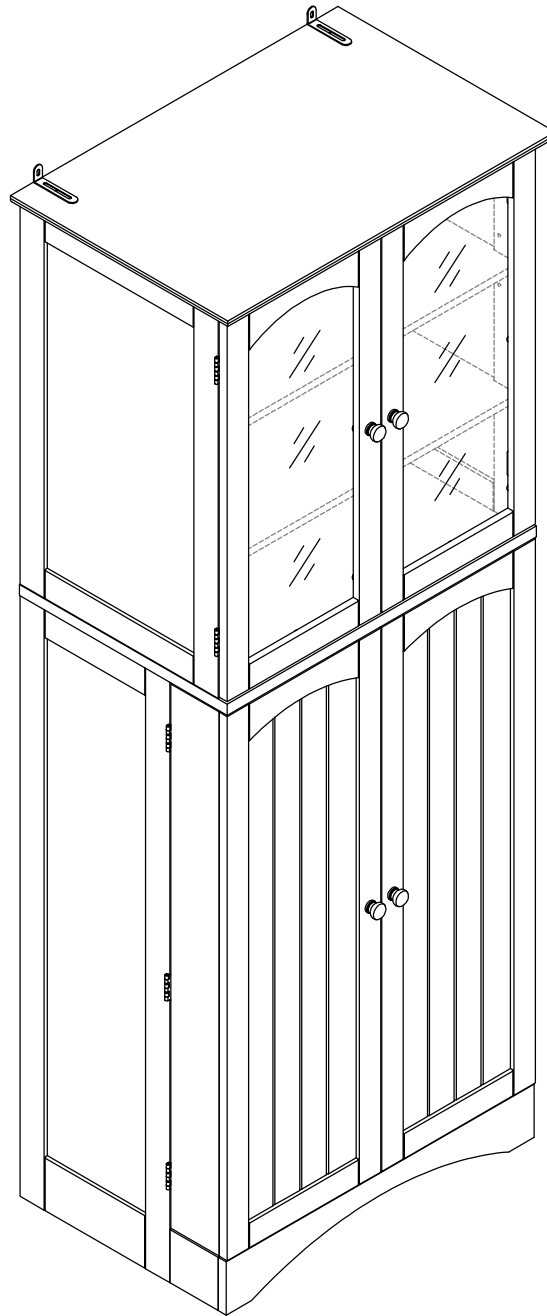

x2



CUSTOMER FIRST, SERVICE FOREMOST!

Questions? Issues?

CONTACT US

REPLY WITHIN 24 HOURS ON WEEKDAYS

Exploded View

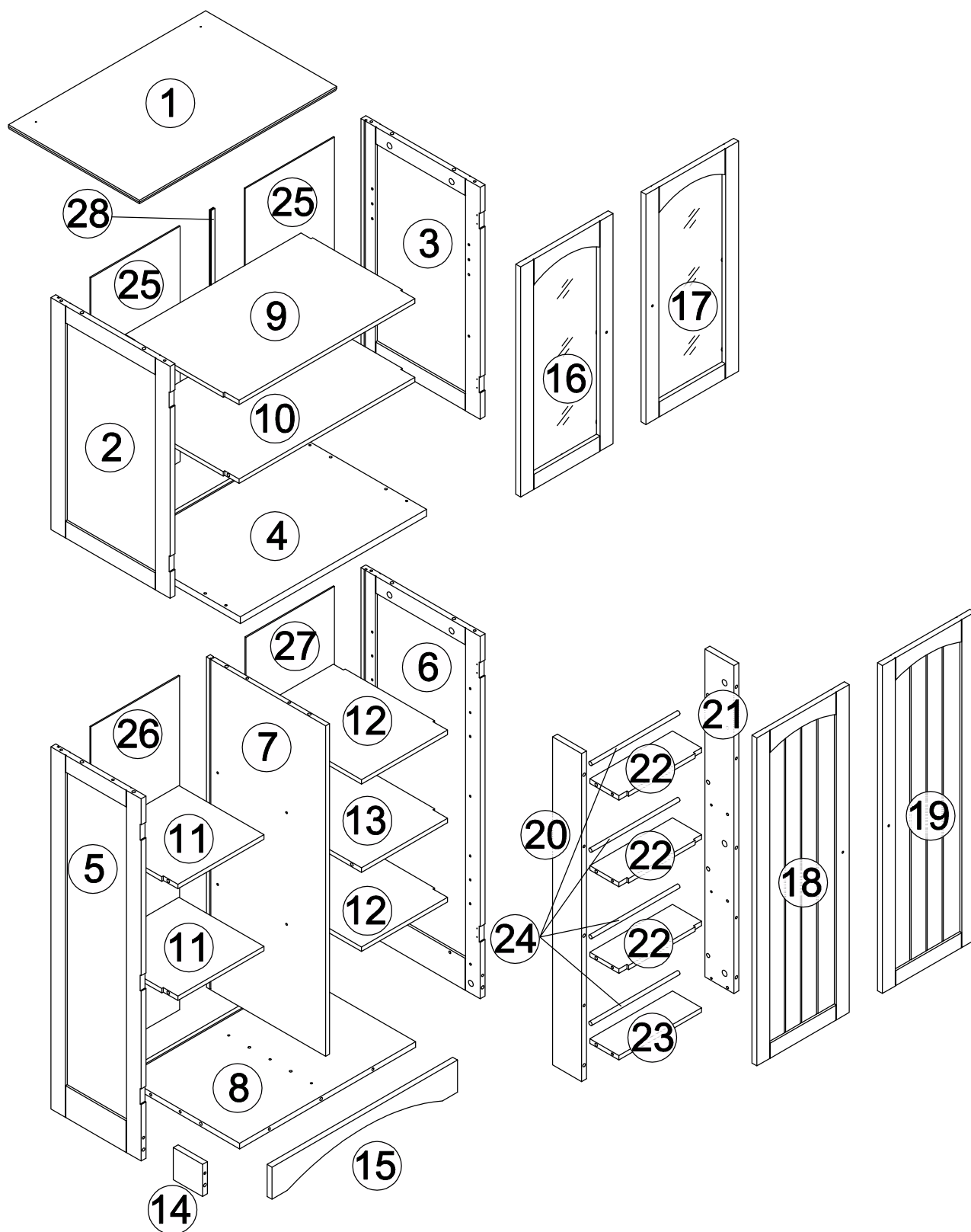

Fittings

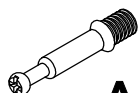

A x 47
M6x35 mm



B x 49
Ø15x9.5 mm

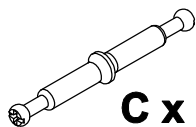

C x 1
Ø6x67 mm

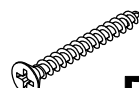

D x 9
Ø4x35 mm



E x 18
Ø3x14 mm



F x 40
Ø3x12 mm



G x 2
Ø4x12 mm

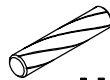

H x 37
Ø6x30 mm



I x 4

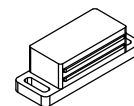

J x 3

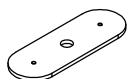

K x 4



L x 6

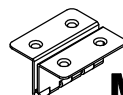

M x 3



N x 12

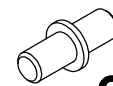

O x 12

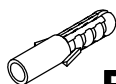

P x 2

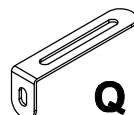

Q x 2

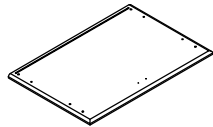
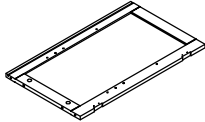
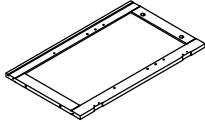
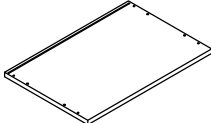
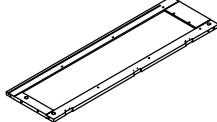
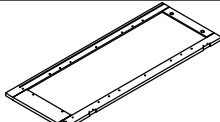
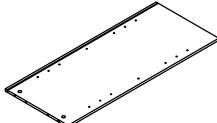
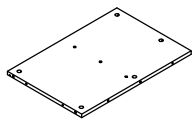
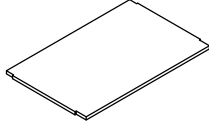
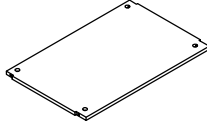
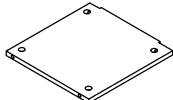
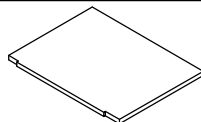
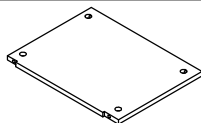
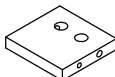

Parts List

Label	Part Image	Description	Qty
①		Top Panel	x1
②		Up Left Side Board	x1
③		Up Right Side Board	x1
④		Middle Vertical Board	x1
⑤		Lower Left Side Board	x1
⑥		Lower Right Side Board	x1
⑦		Middle Partition	x1
⑧		Bottom Board	x1
⑨		Upper Active Laminate	x1
⑩		Upper Plate	x1
⑪		Lower Left Board	x2
⑫		Lower Active Laminate	x2
⑬		Lower Righth Board	x1
⑭		Bottom stick block	x1

Parts List

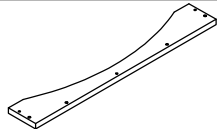
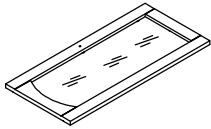
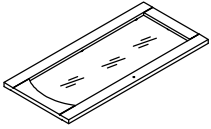
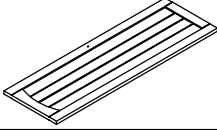
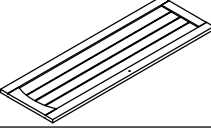
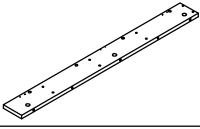
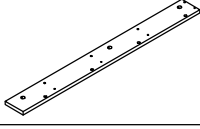
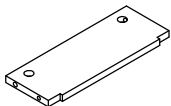
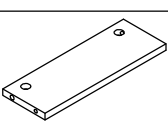
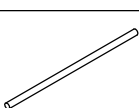
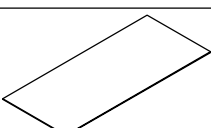
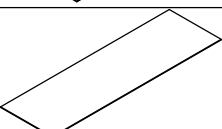
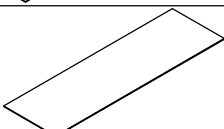
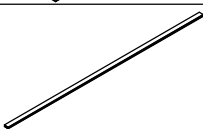
Label	Part Image	Description	Qty
15		Bottom front bar	x1
16		Up Left Door Board	x1
17		Up Right Door Board	x1
18		Lower Left Door Board	x1
19		Lower Right Door Board	x1
20		Door Left Panel	x1
21		Door Right Panel	x1
22		Upper Plate Inside The Door	x3
23		The Floor Of The Door	x1
24		Round stick	x4
25		Upper Back Board	x2
26		Lower Left Back Board	x1
27		Lower Right Back Board	x1
28		Upper Back Stand Bar	x1

Step 1

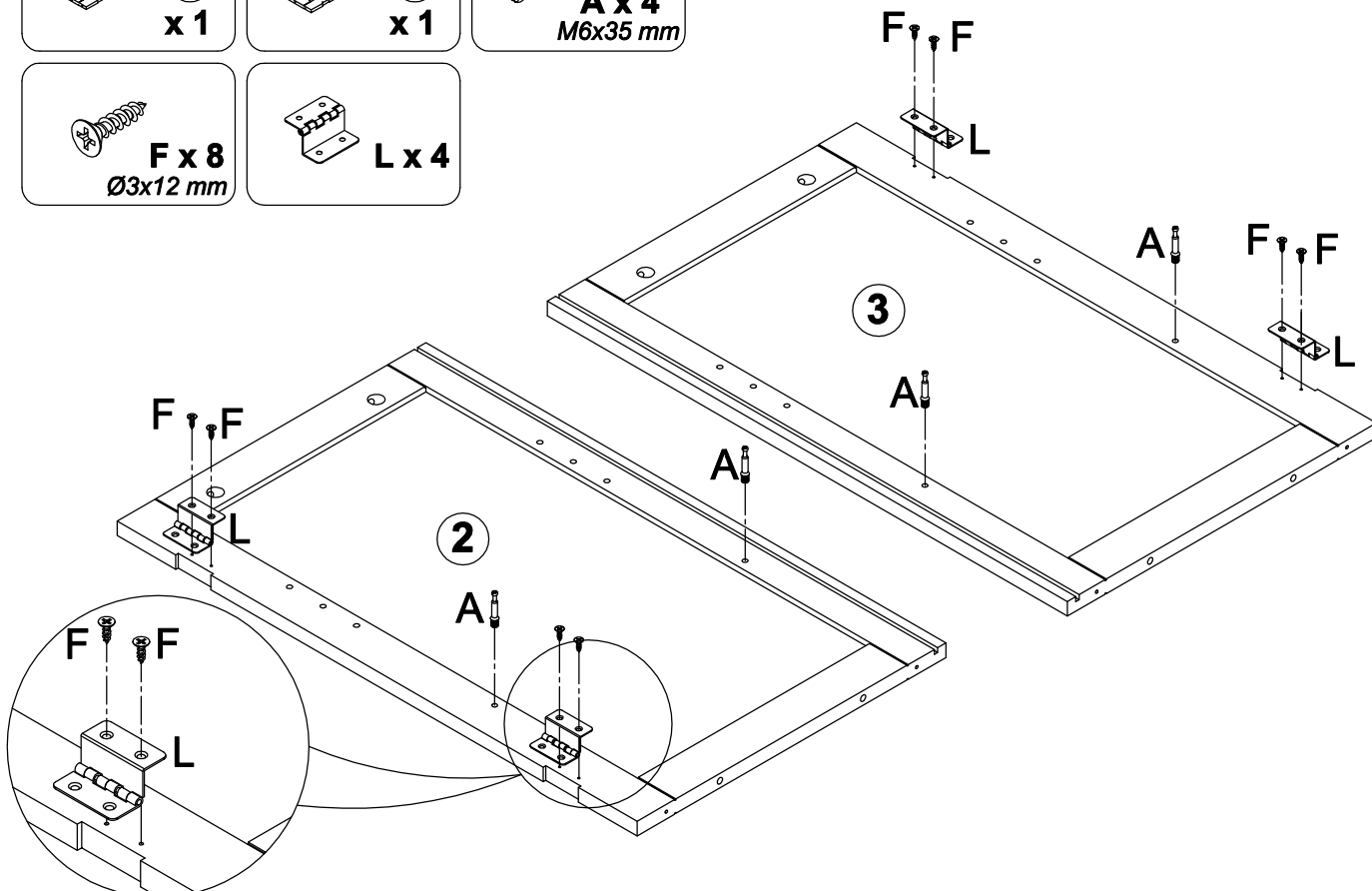
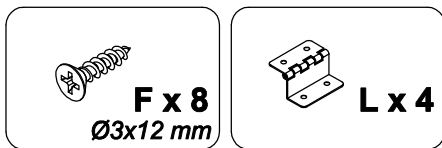
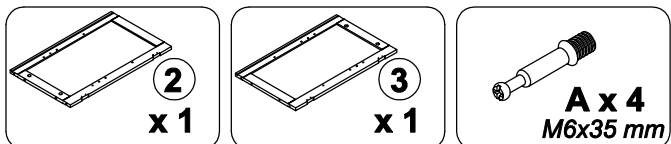

Step 2

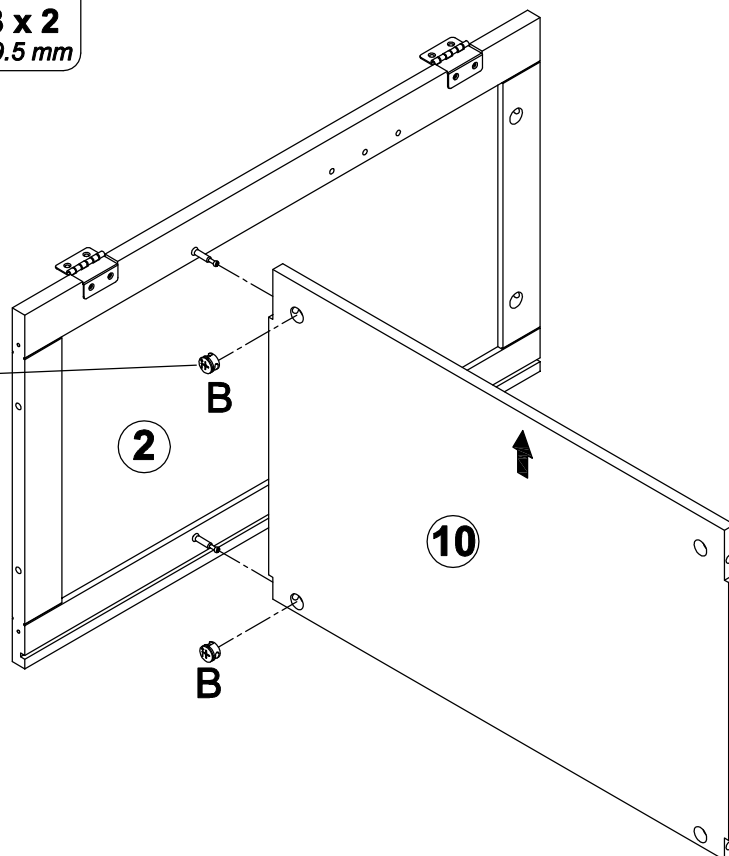
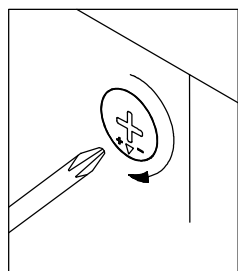
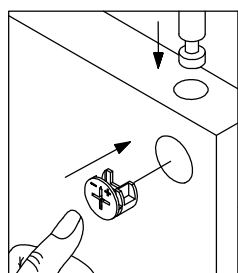
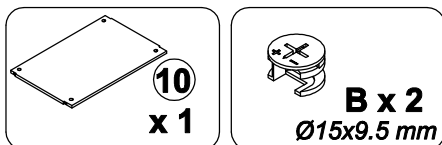

Step 3

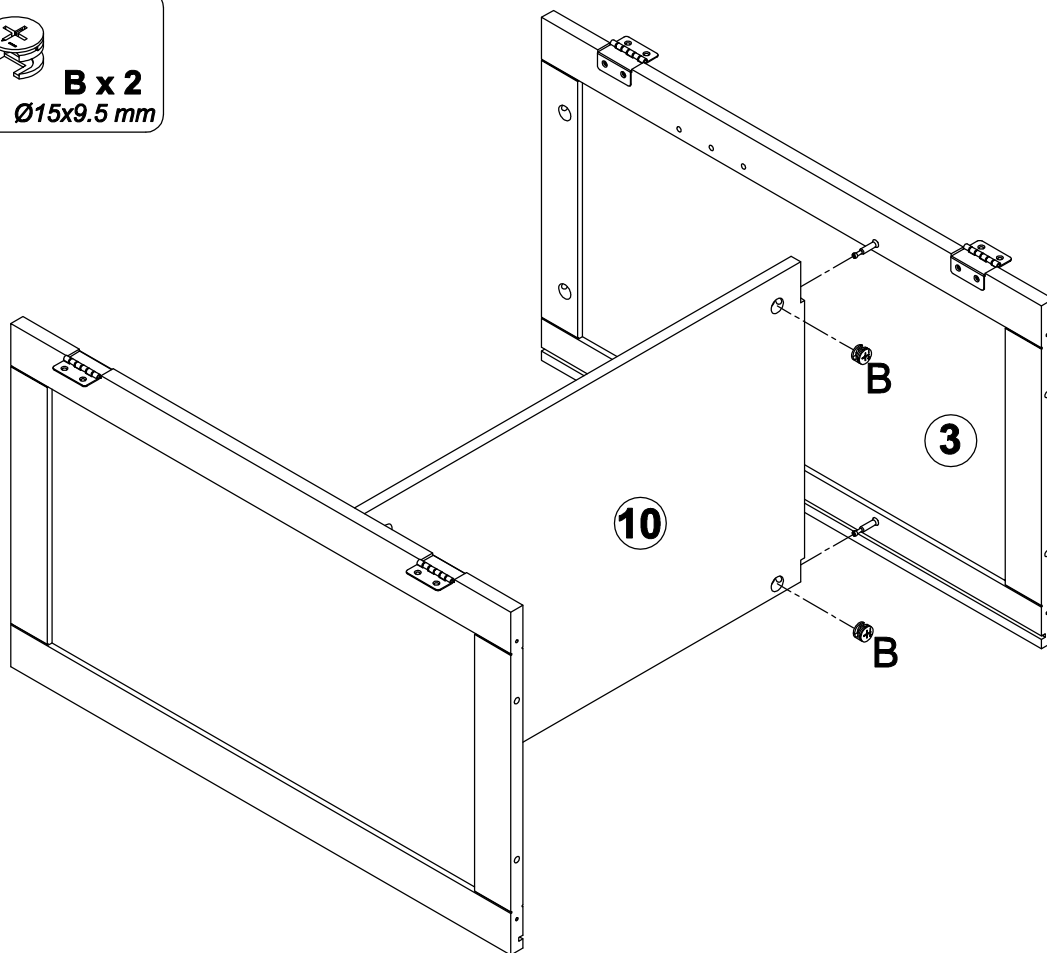
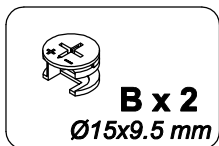

Step 4

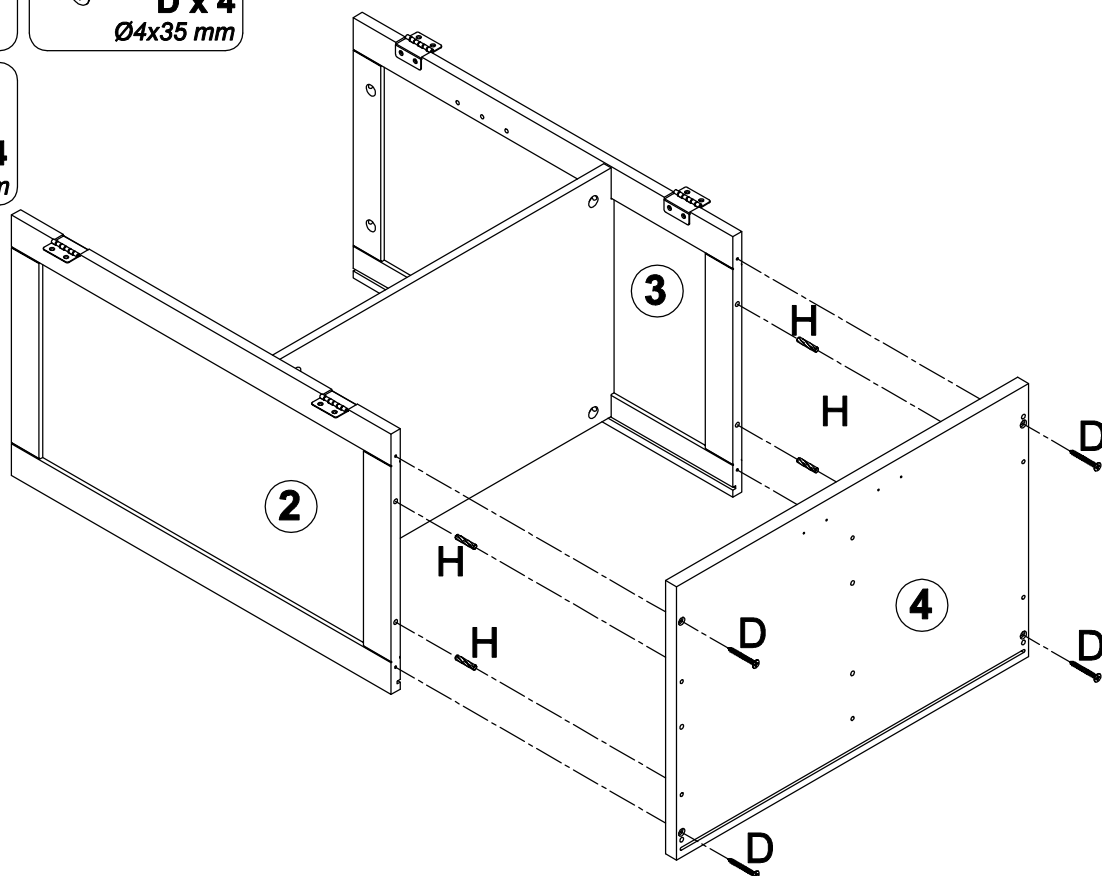
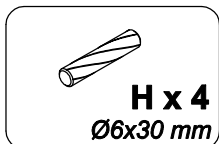
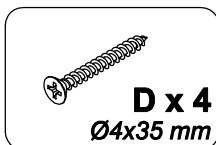
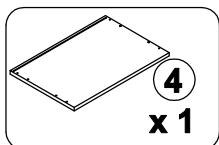

Step 5

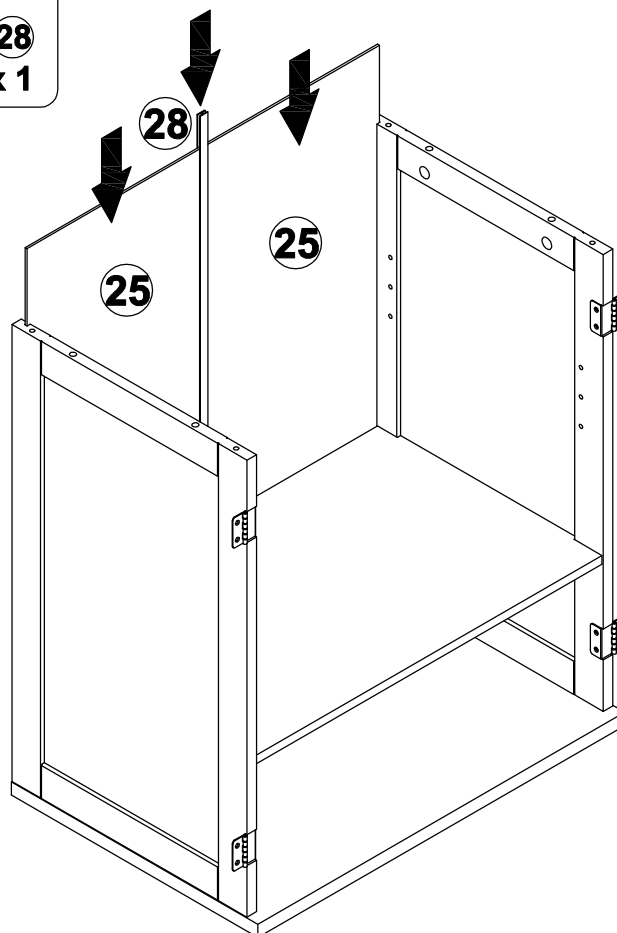
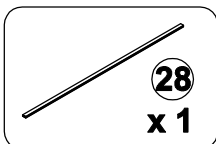
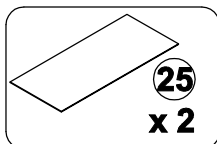

Step 6

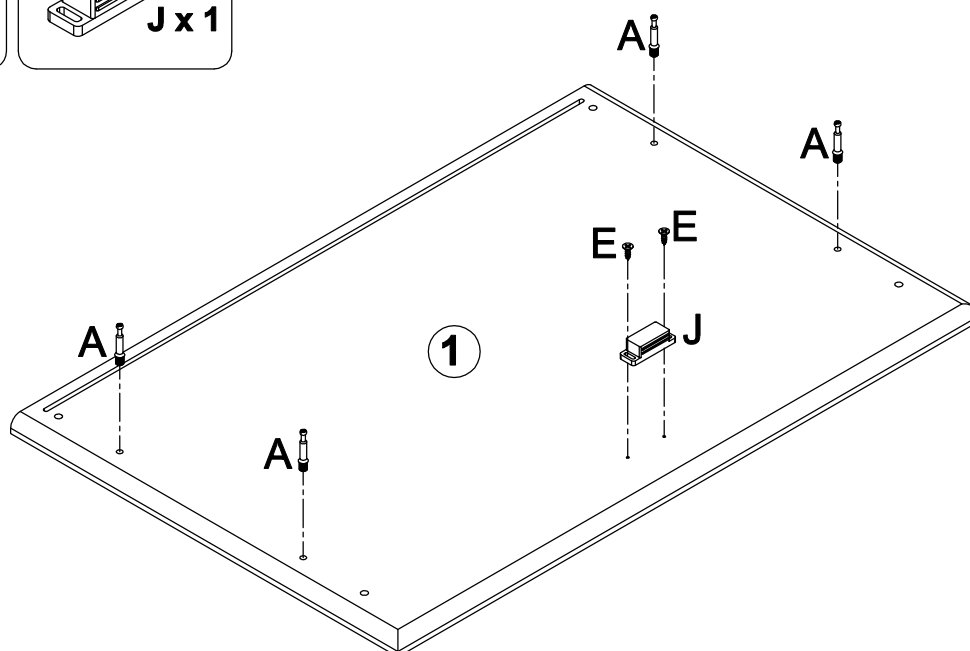
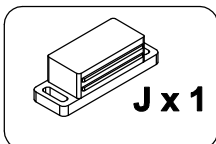
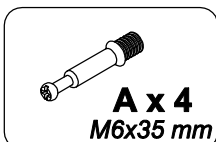
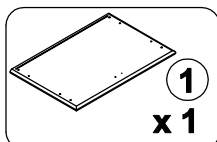

Step 7

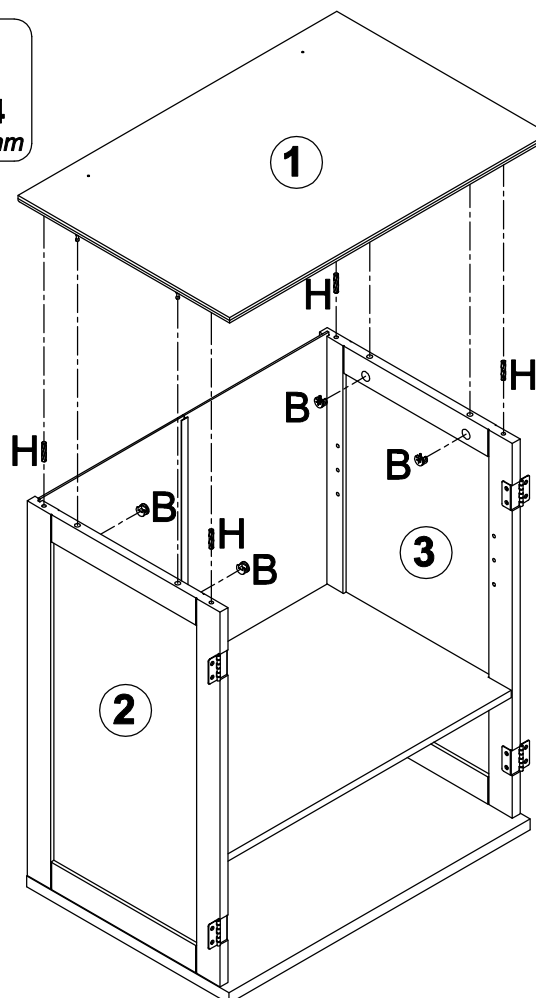
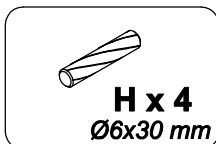
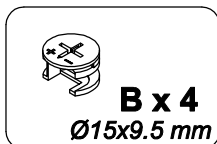

Step 8

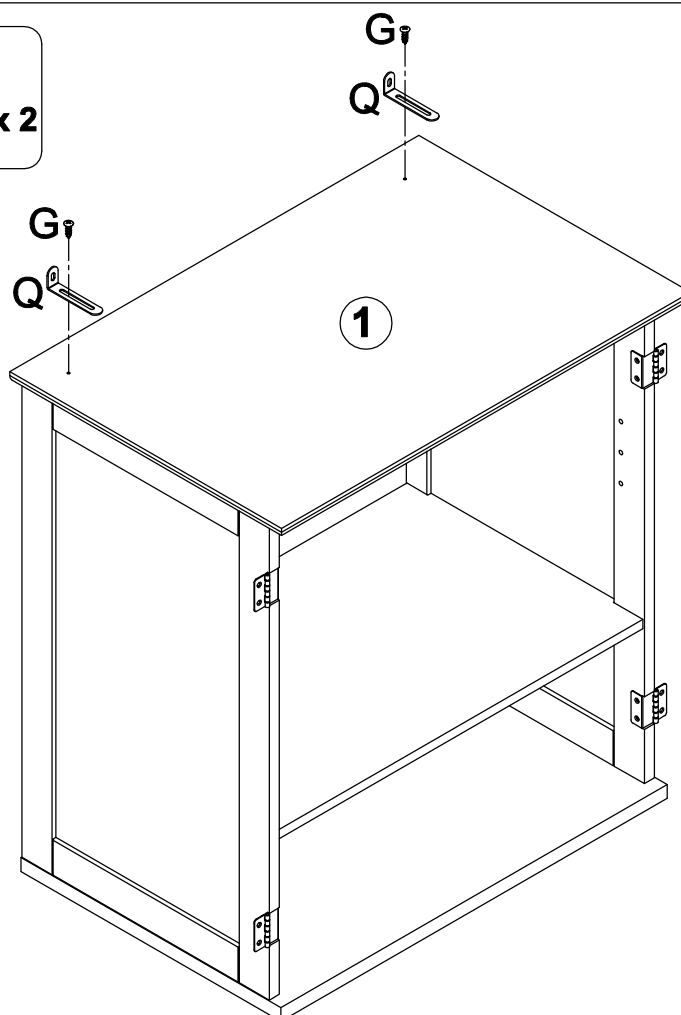
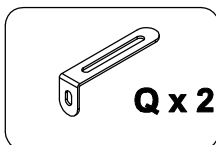

Step 9

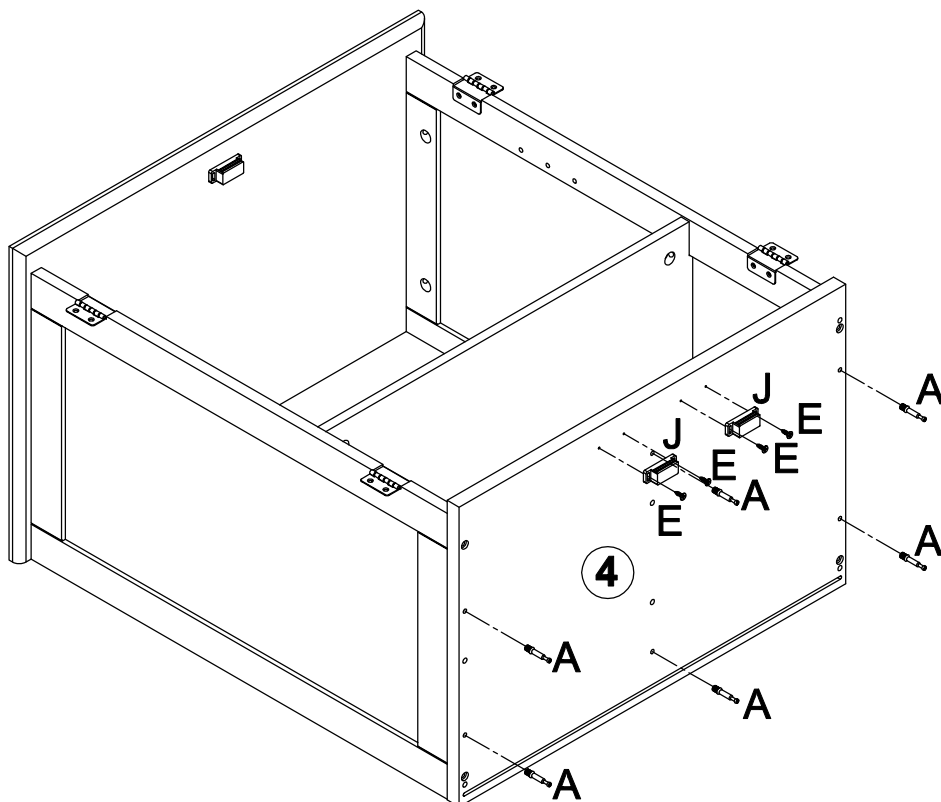
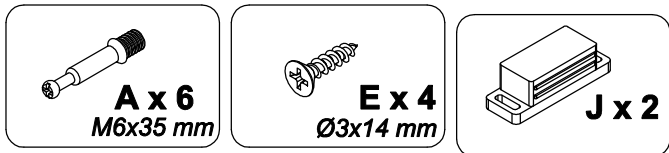

Step 10

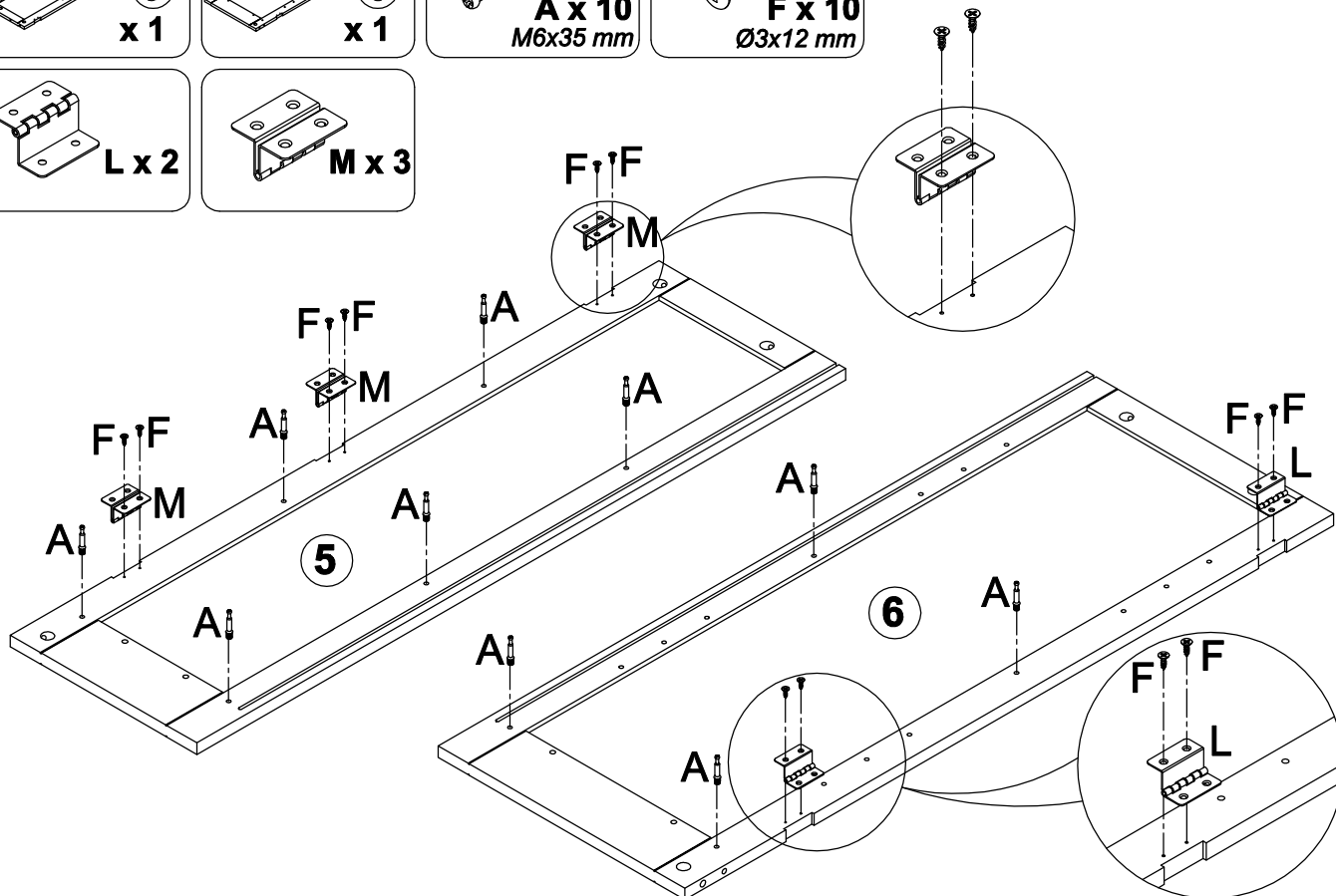
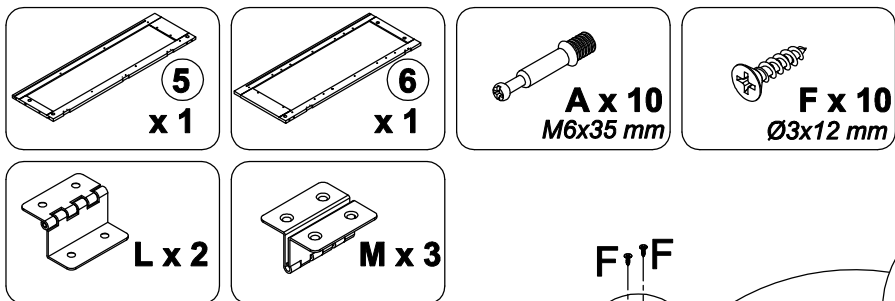

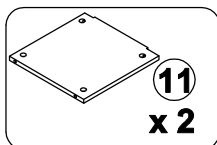
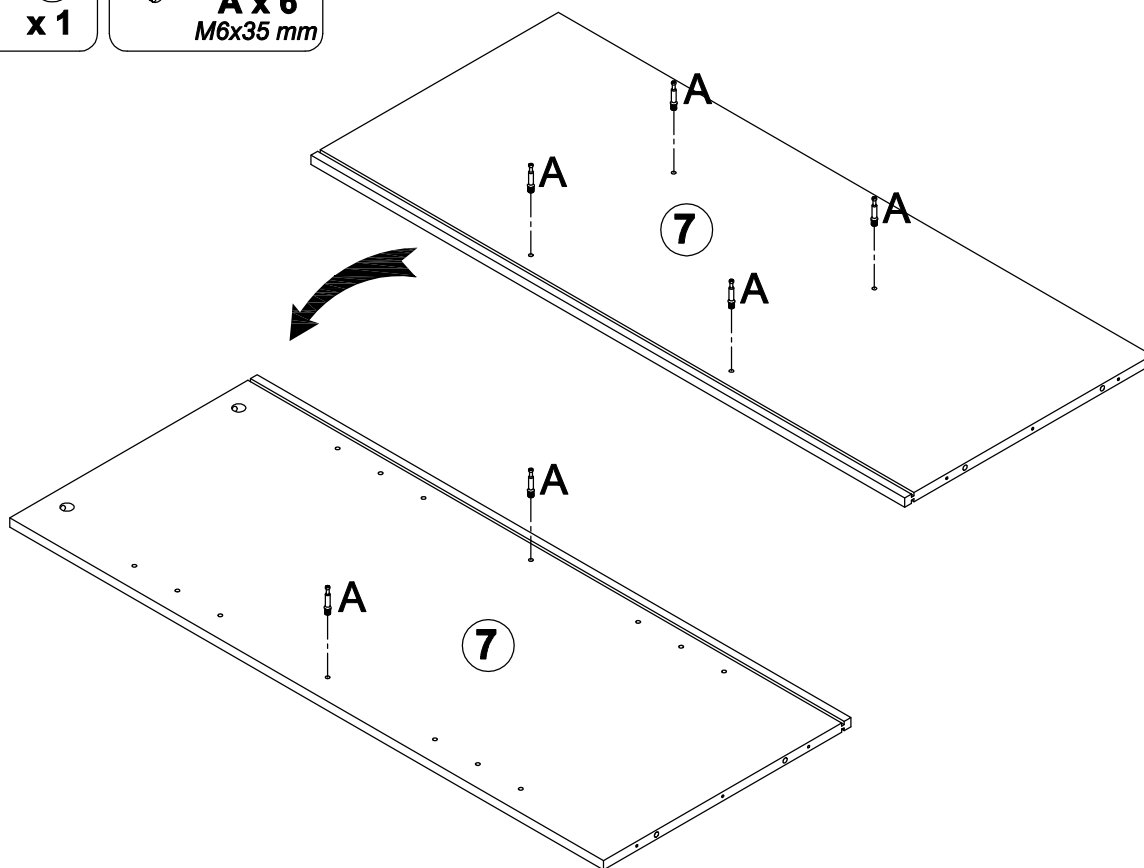
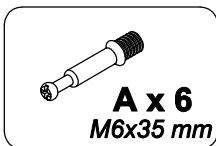
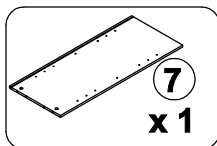
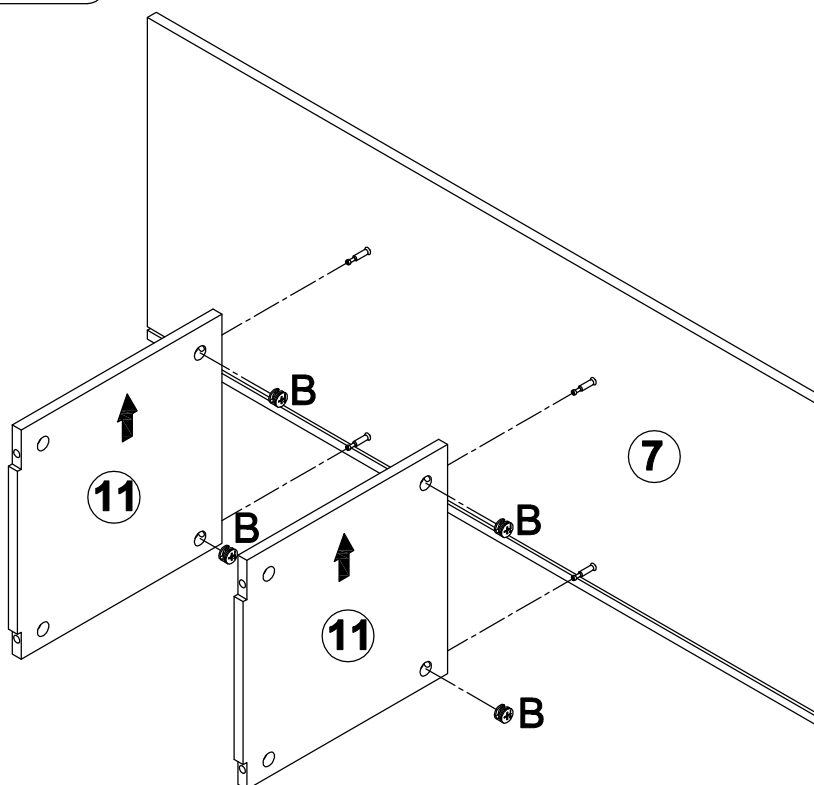
Step 11**Step 12**

Step 13

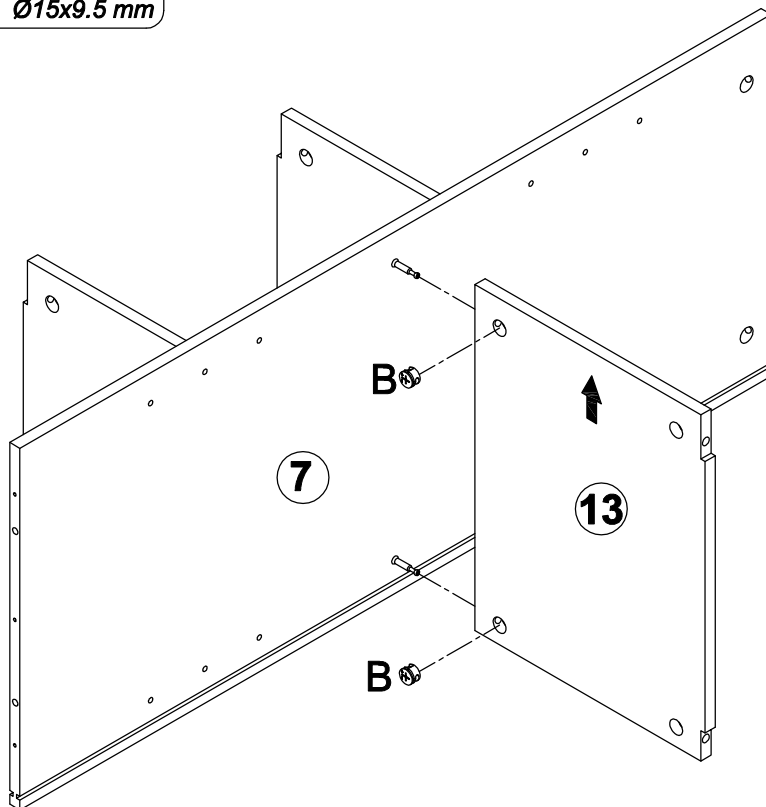
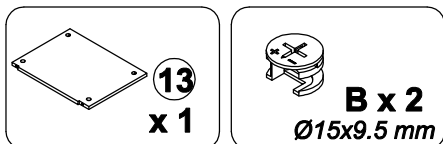

Step 14

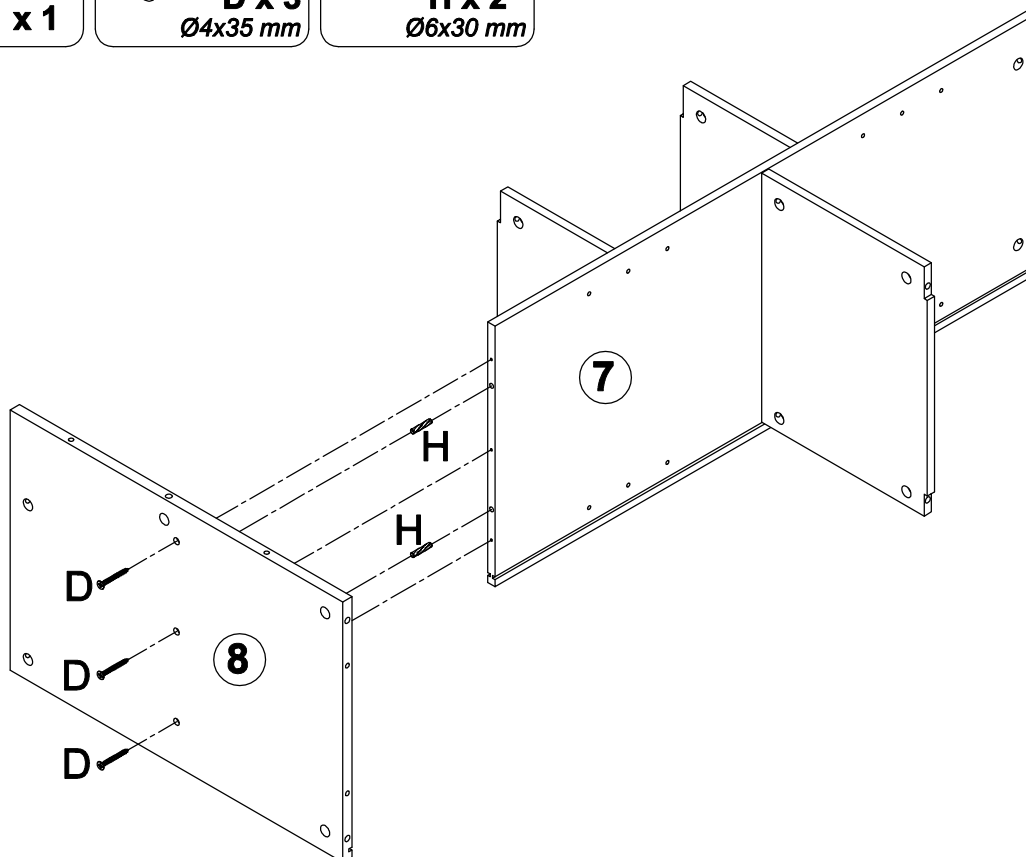
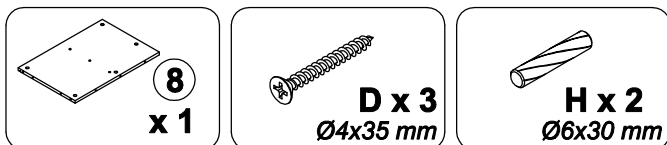

Step 15

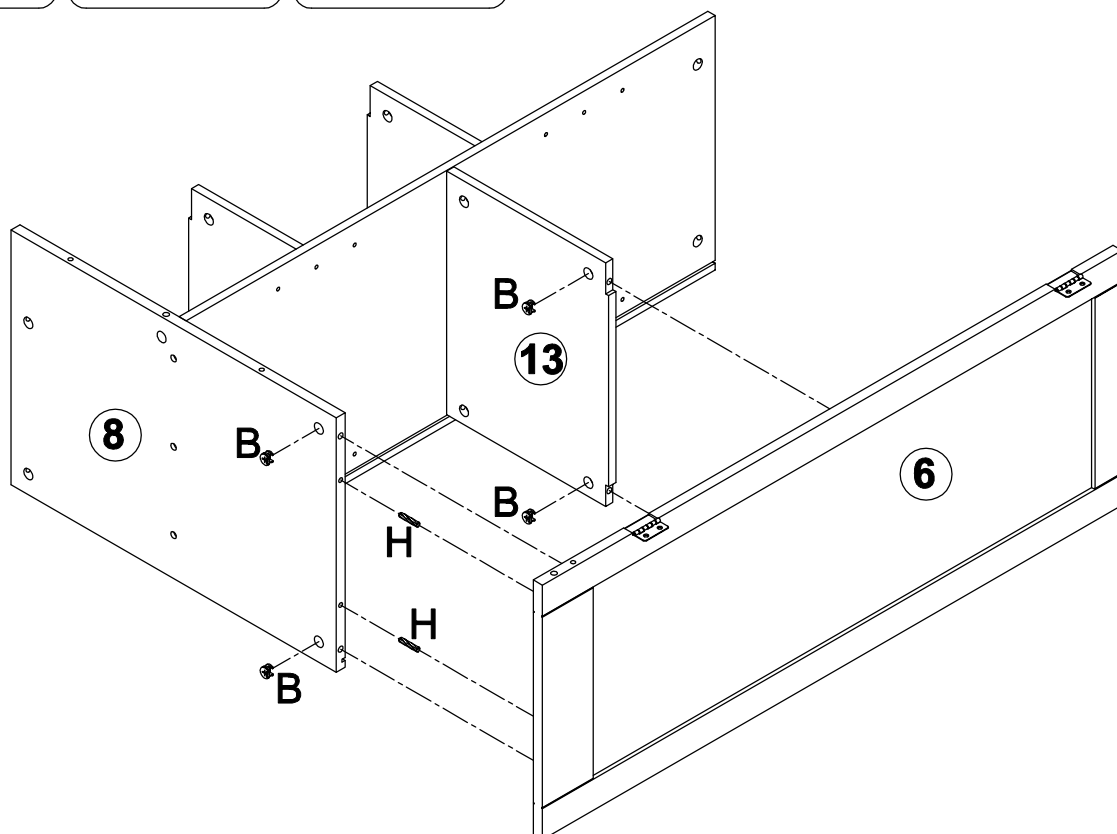
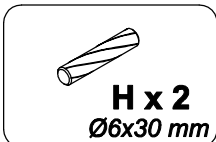
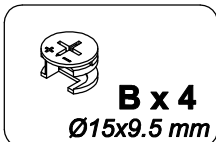
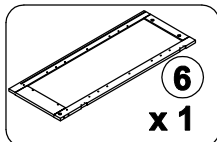

Step 16

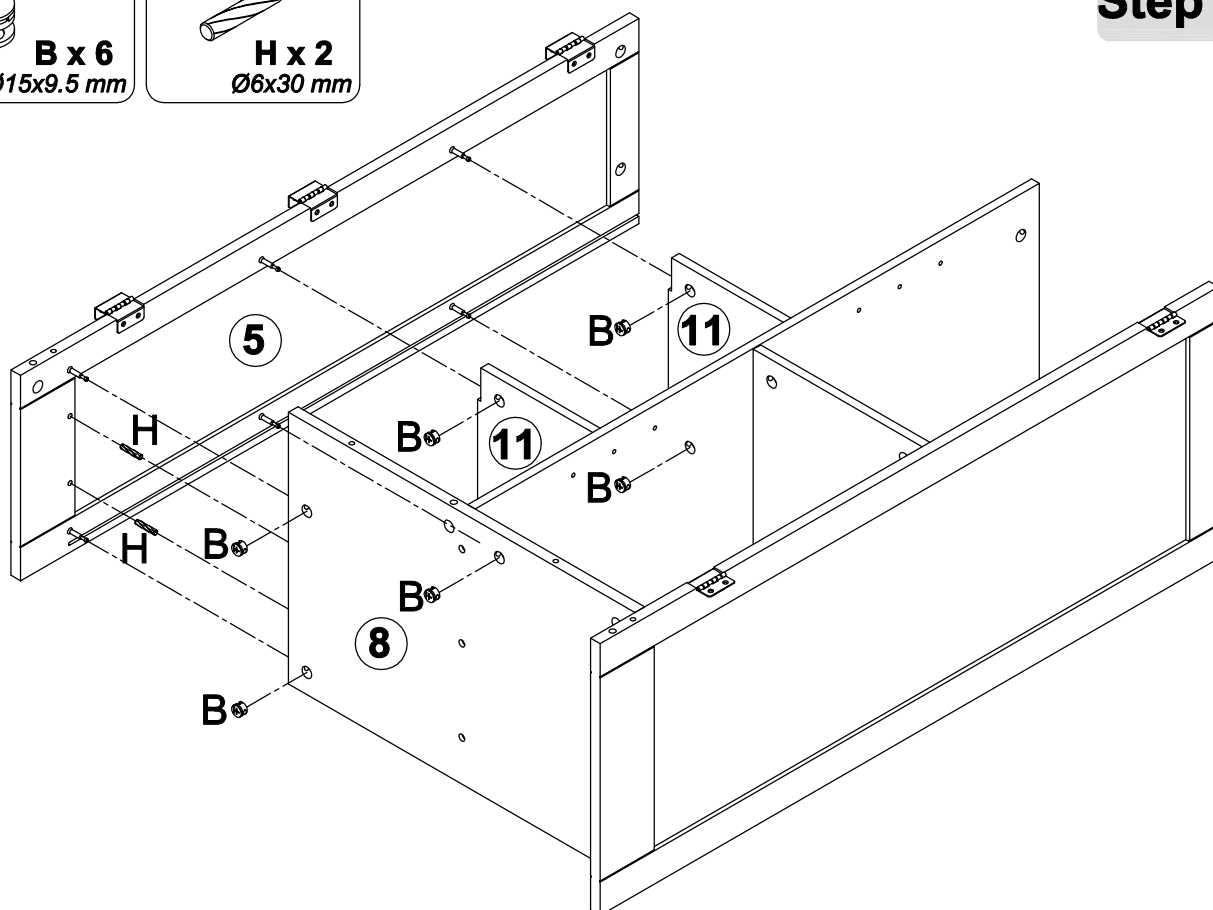
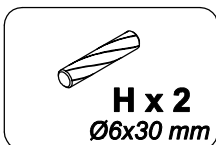
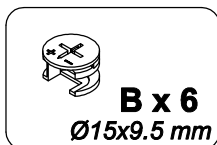

Step 17

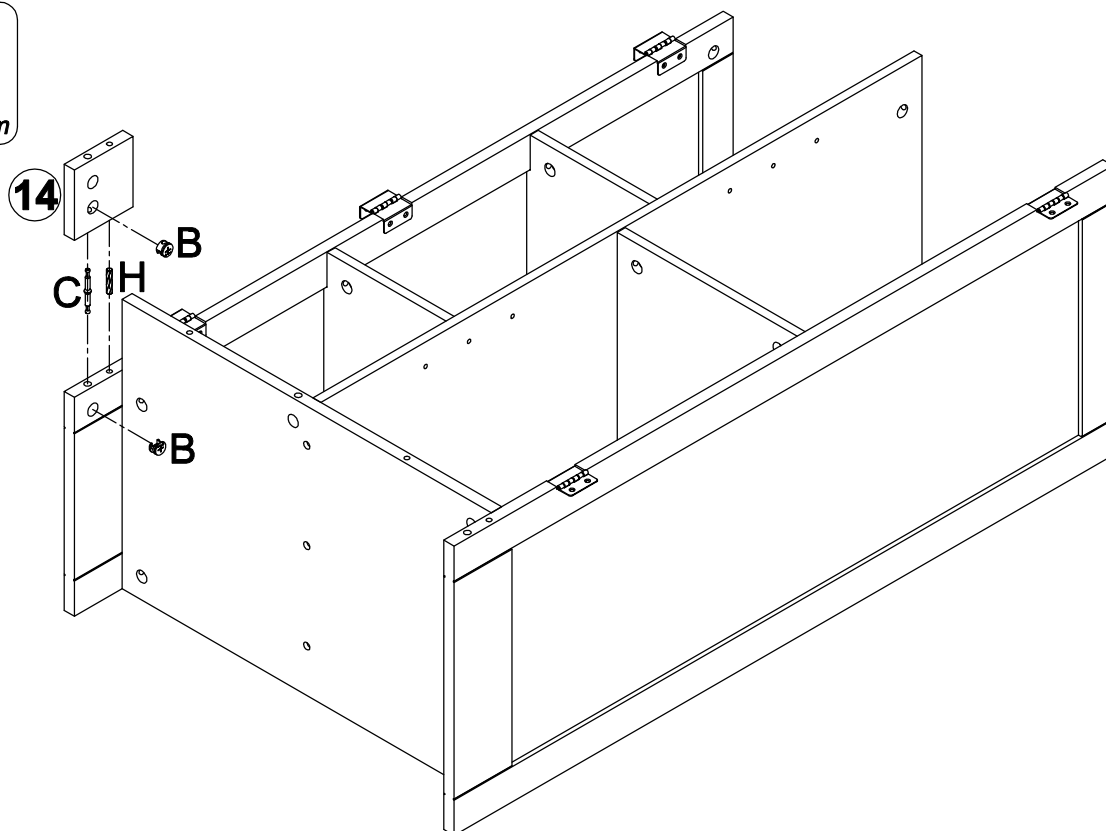
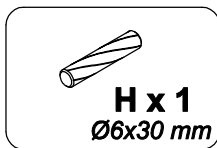
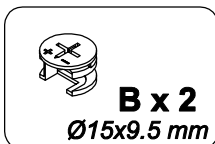
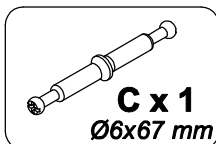
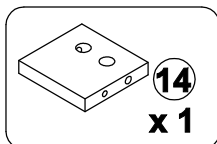

Step 18

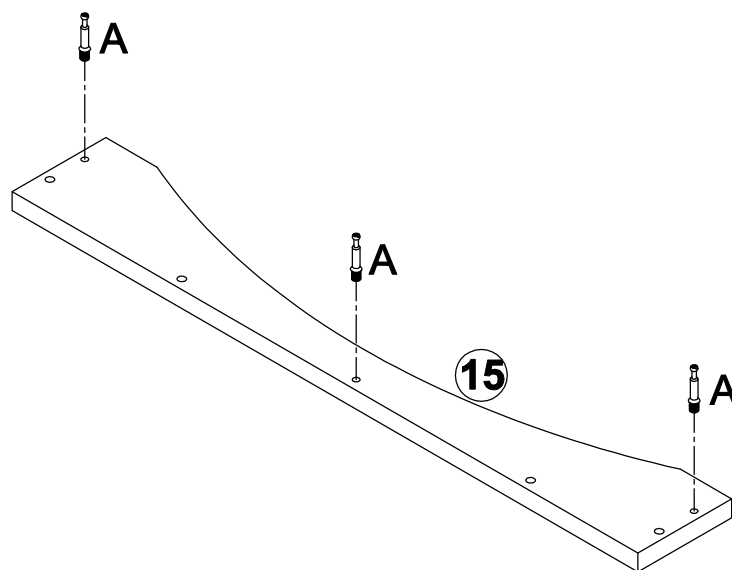
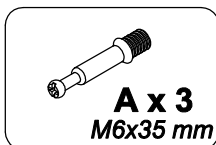
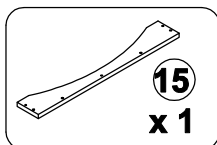

Step 19

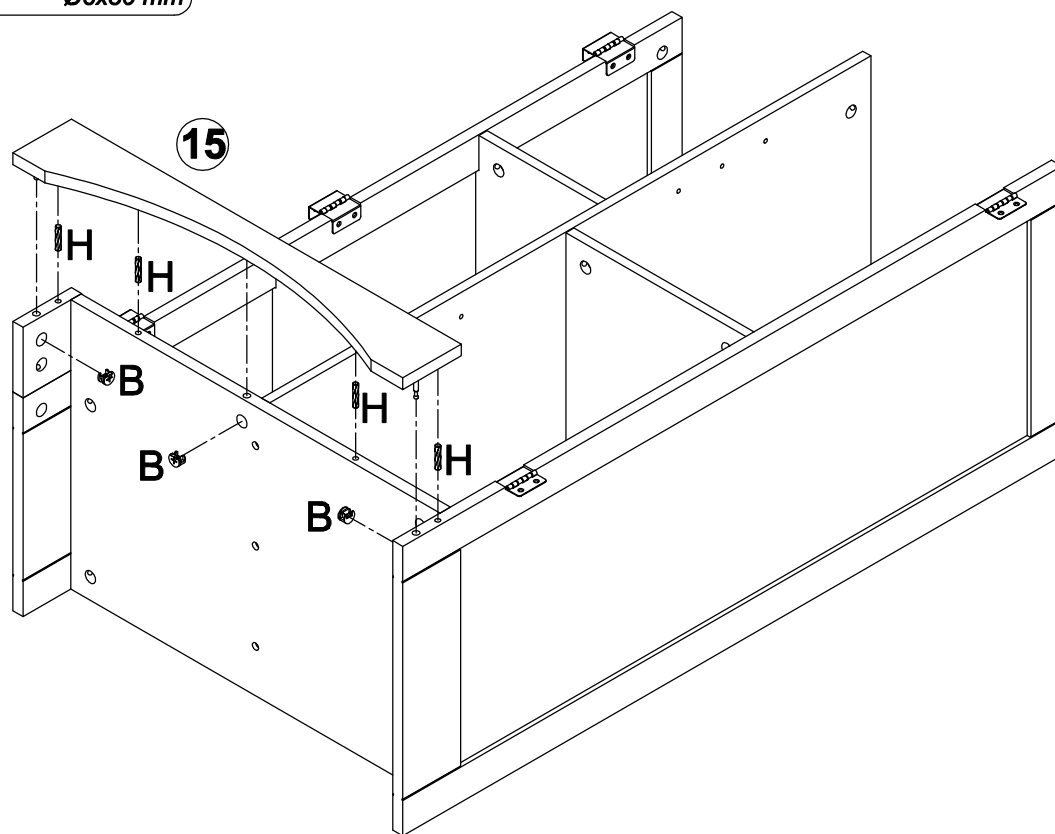
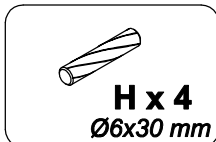
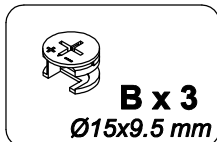

Step 20

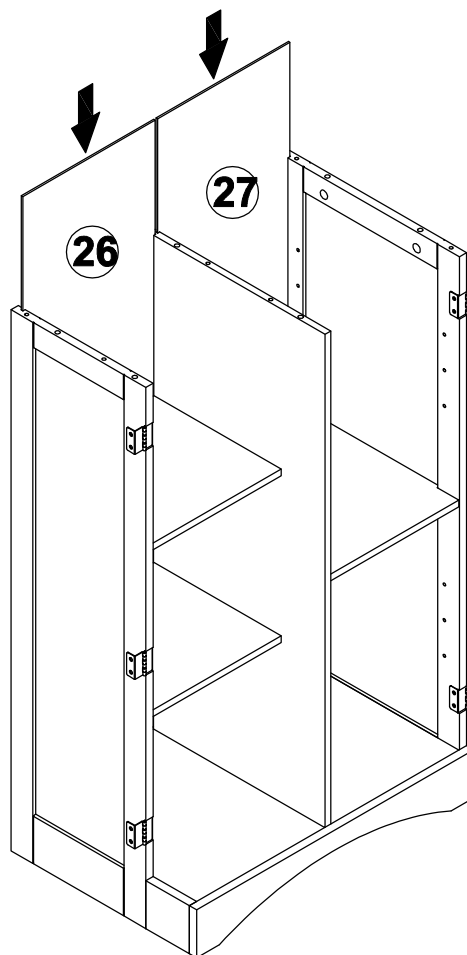
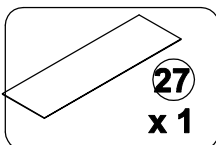
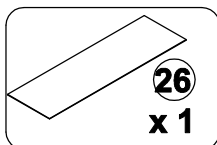

Step 21

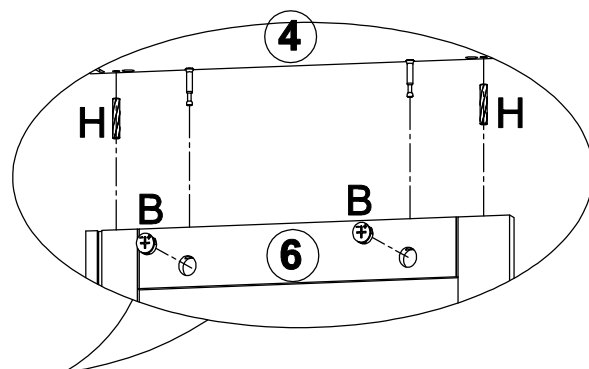
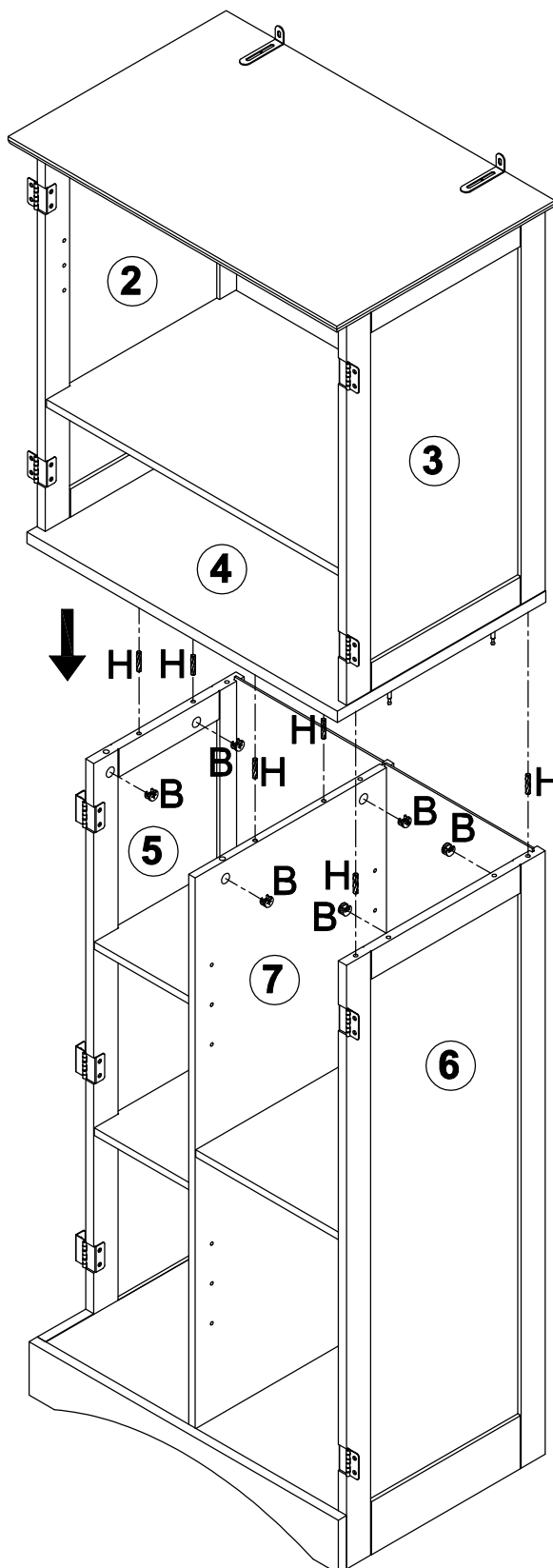
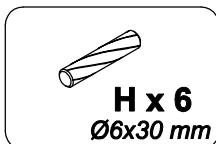
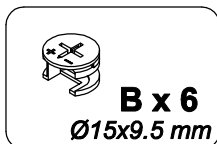

Attention:
Ensure that each eccentric is tightened.

Step 22

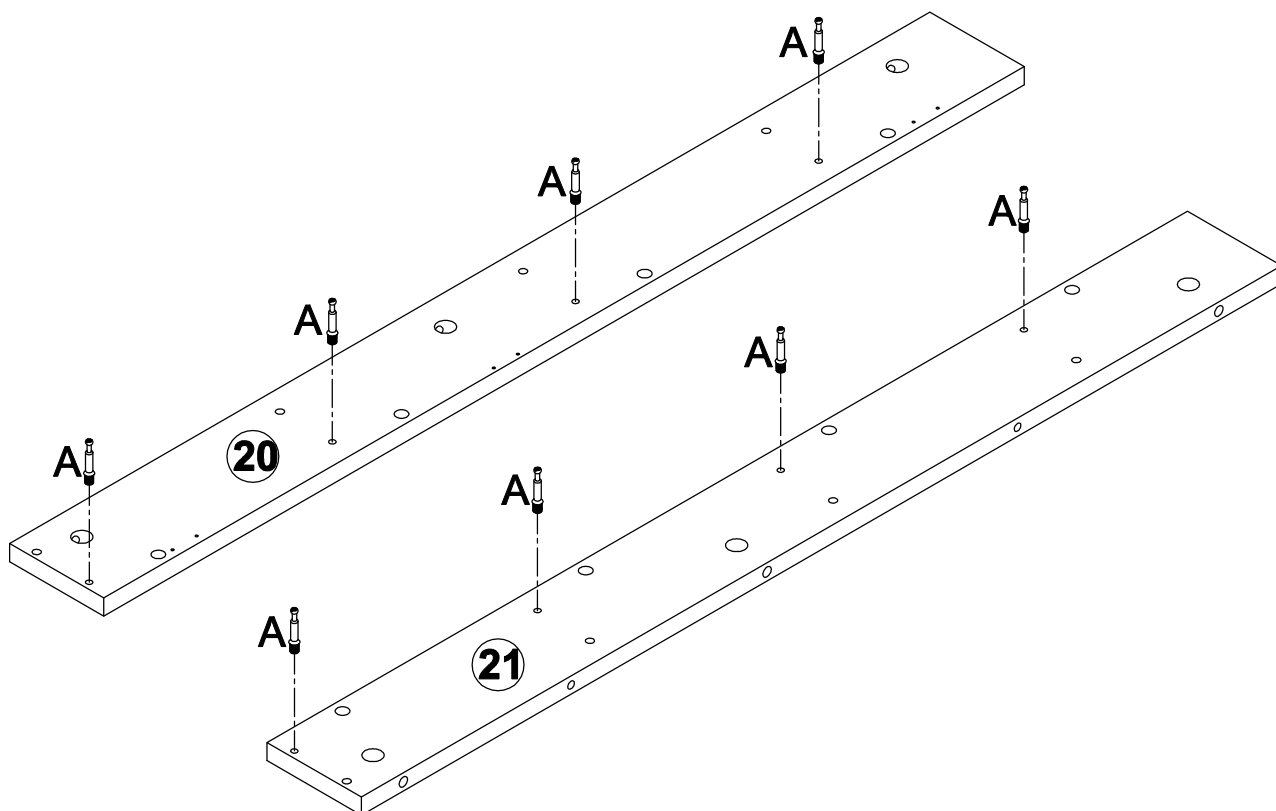
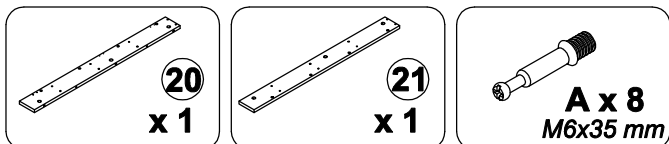

Step 23

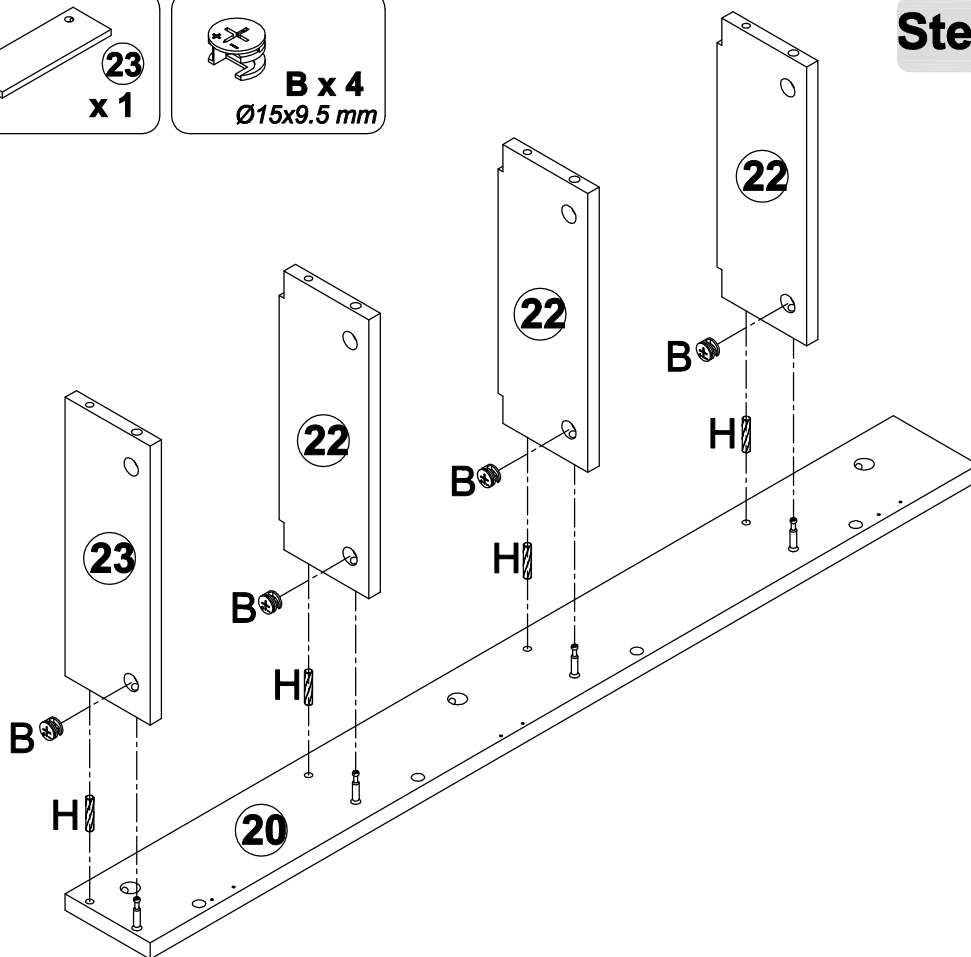
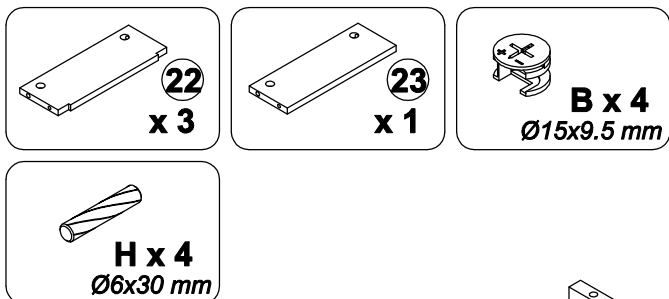

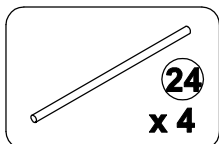

Step 24

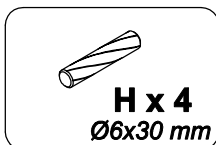
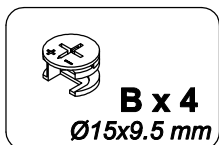
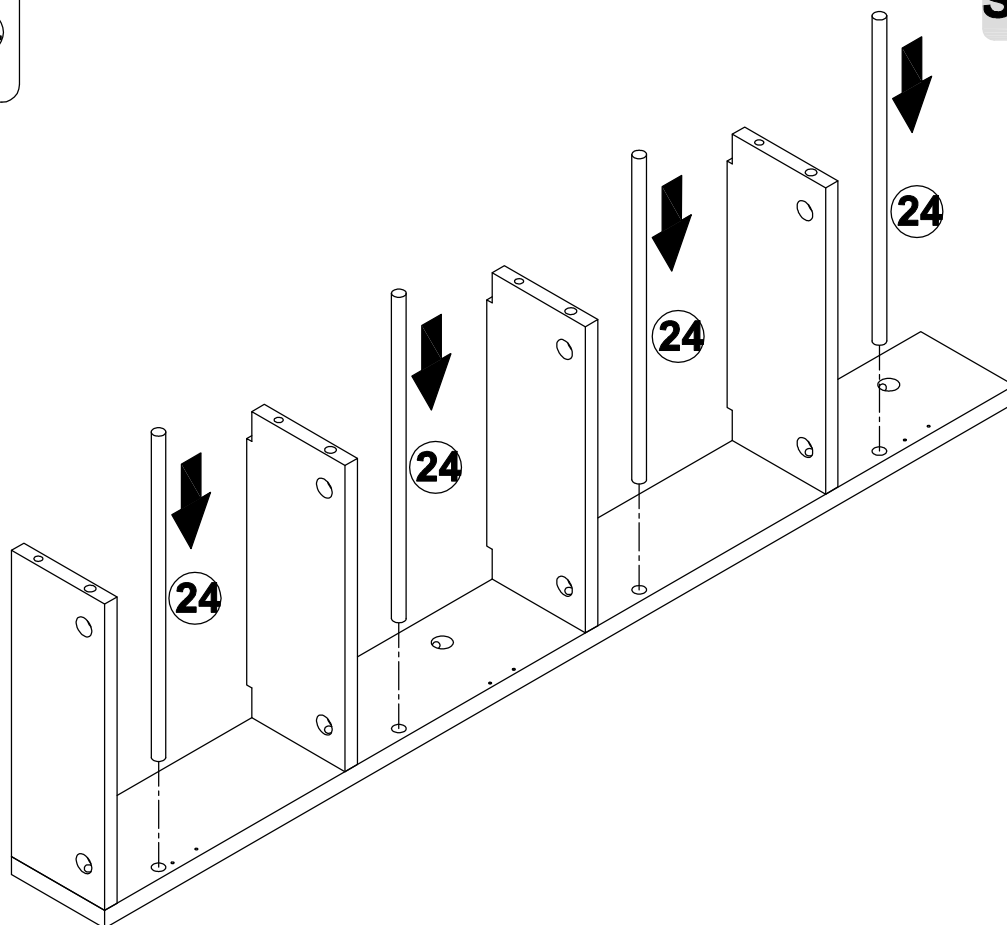

Step 25

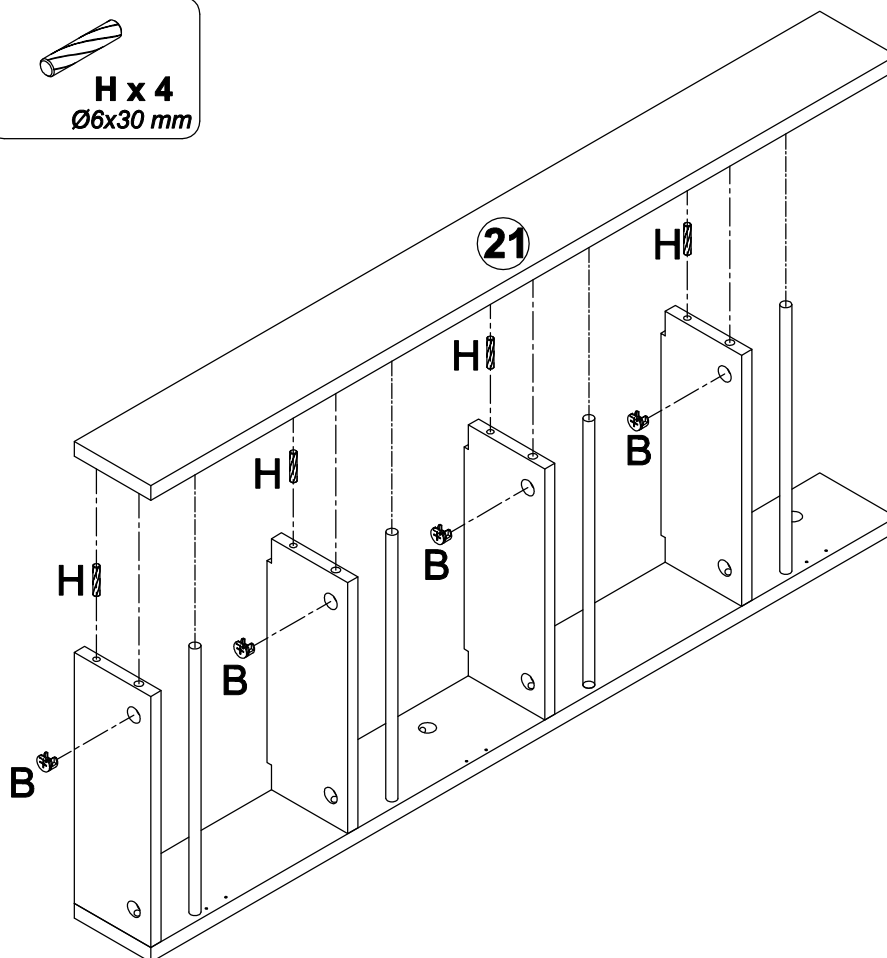

Step 26

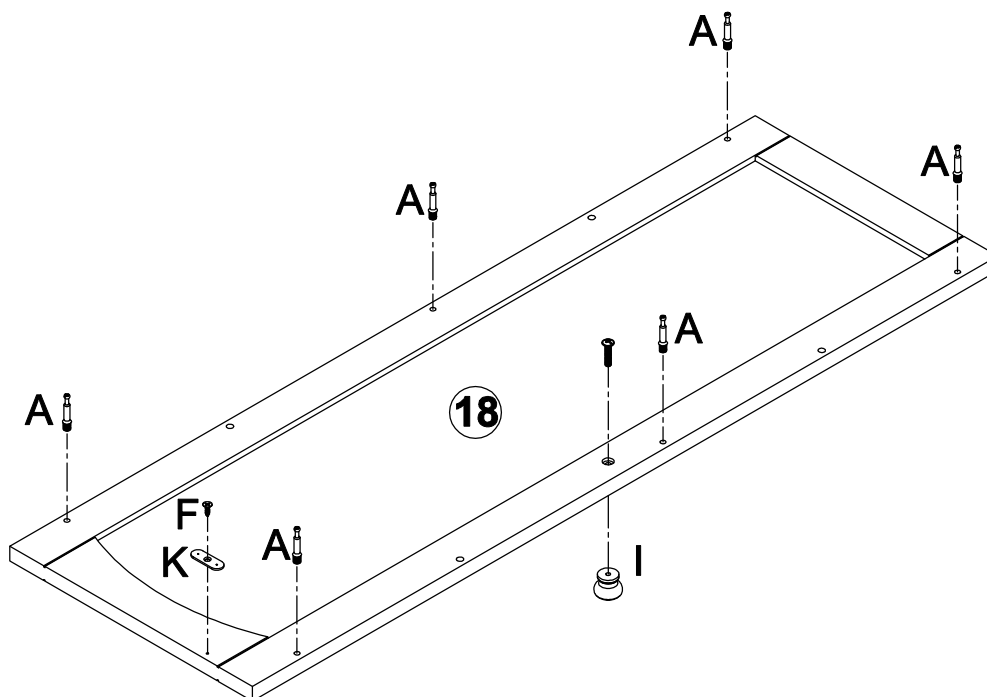
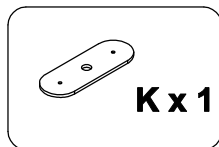
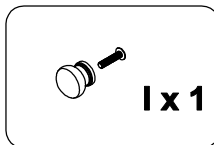
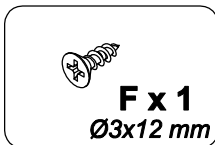
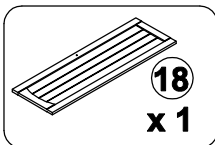

Step 27

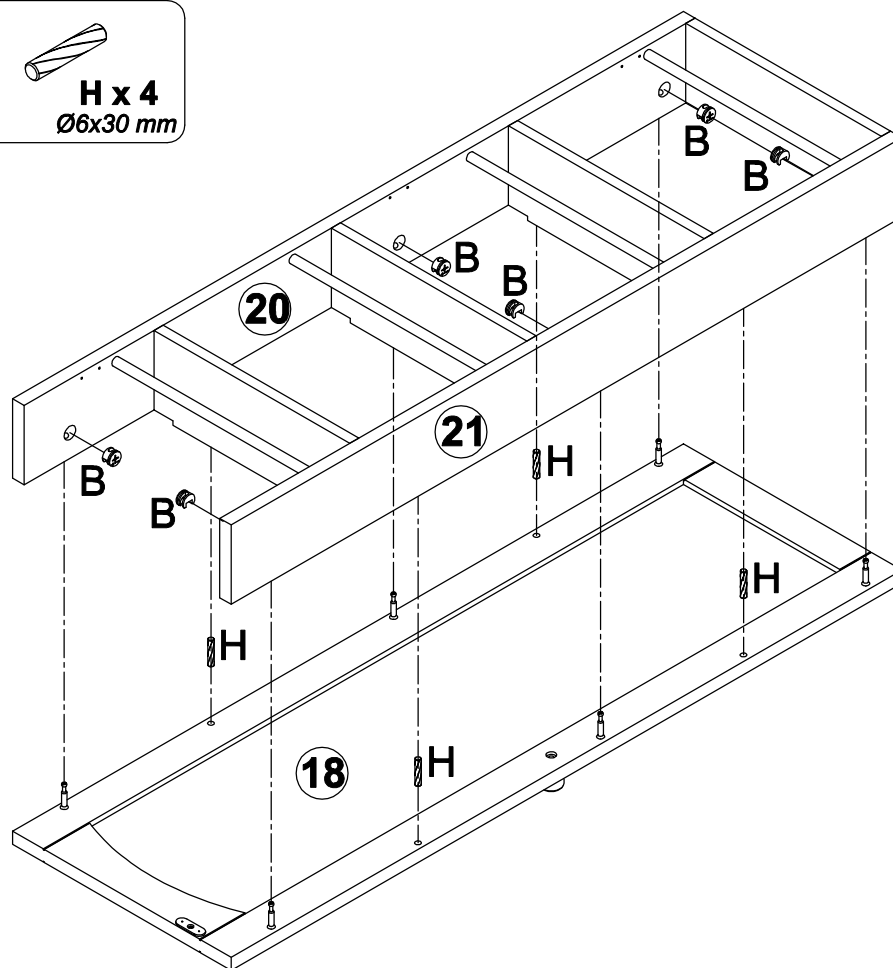
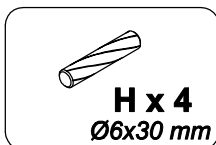
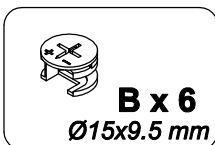

Step 28

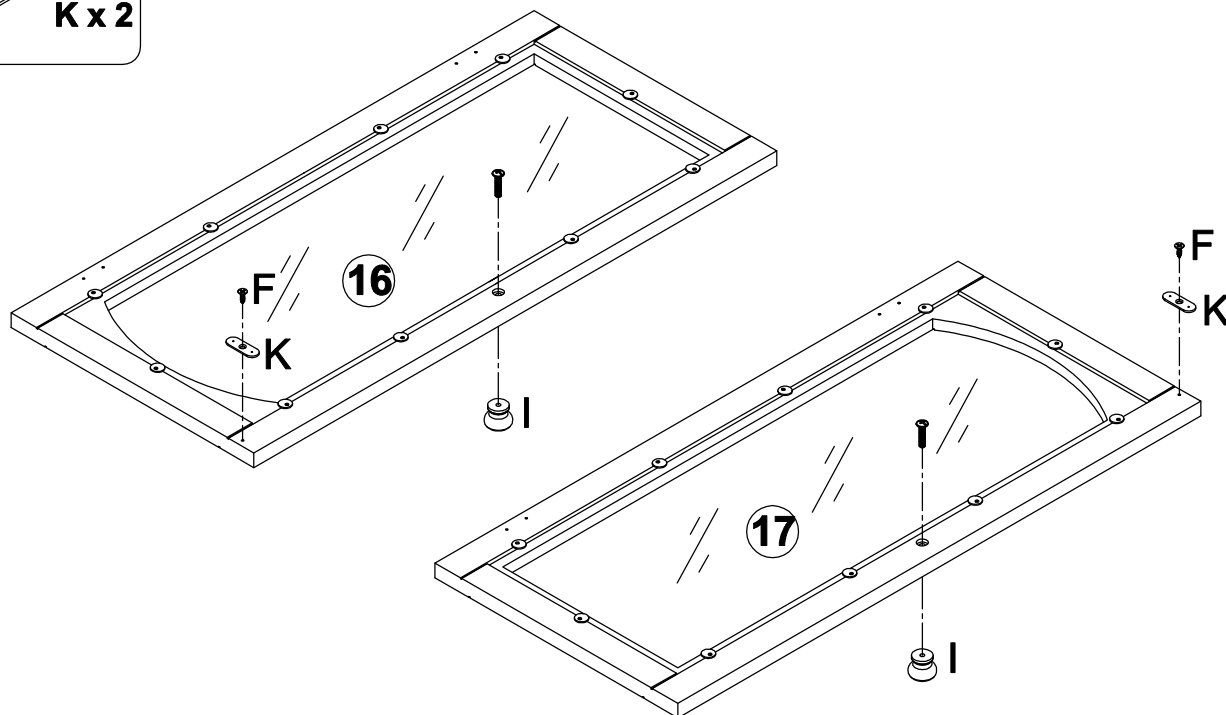
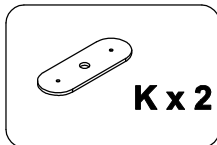
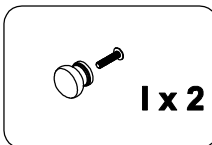
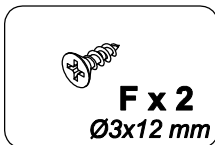
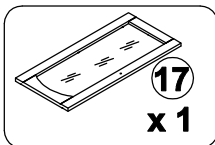
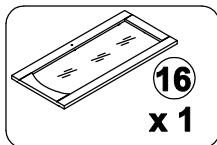

Step 29

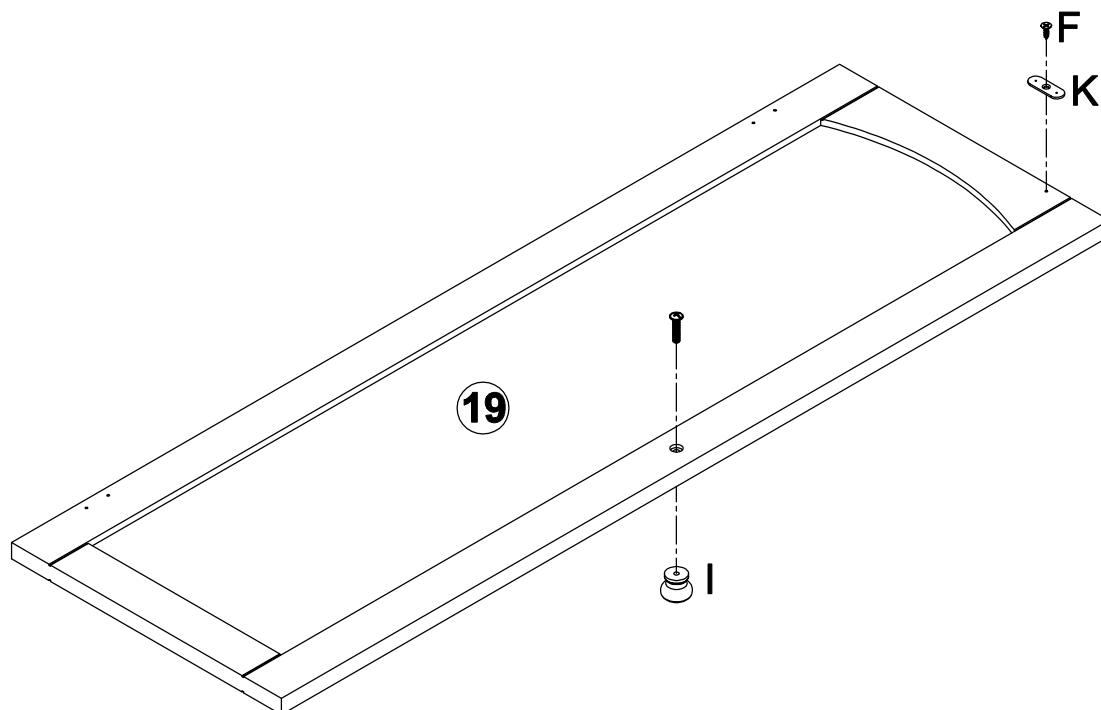
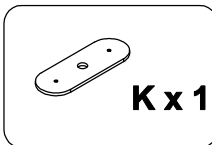
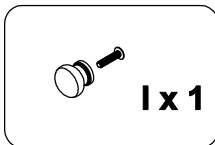
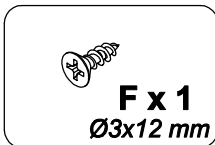
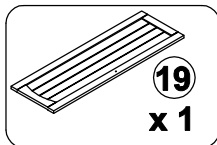

Step 30

F x 18
Ø3x12 mm

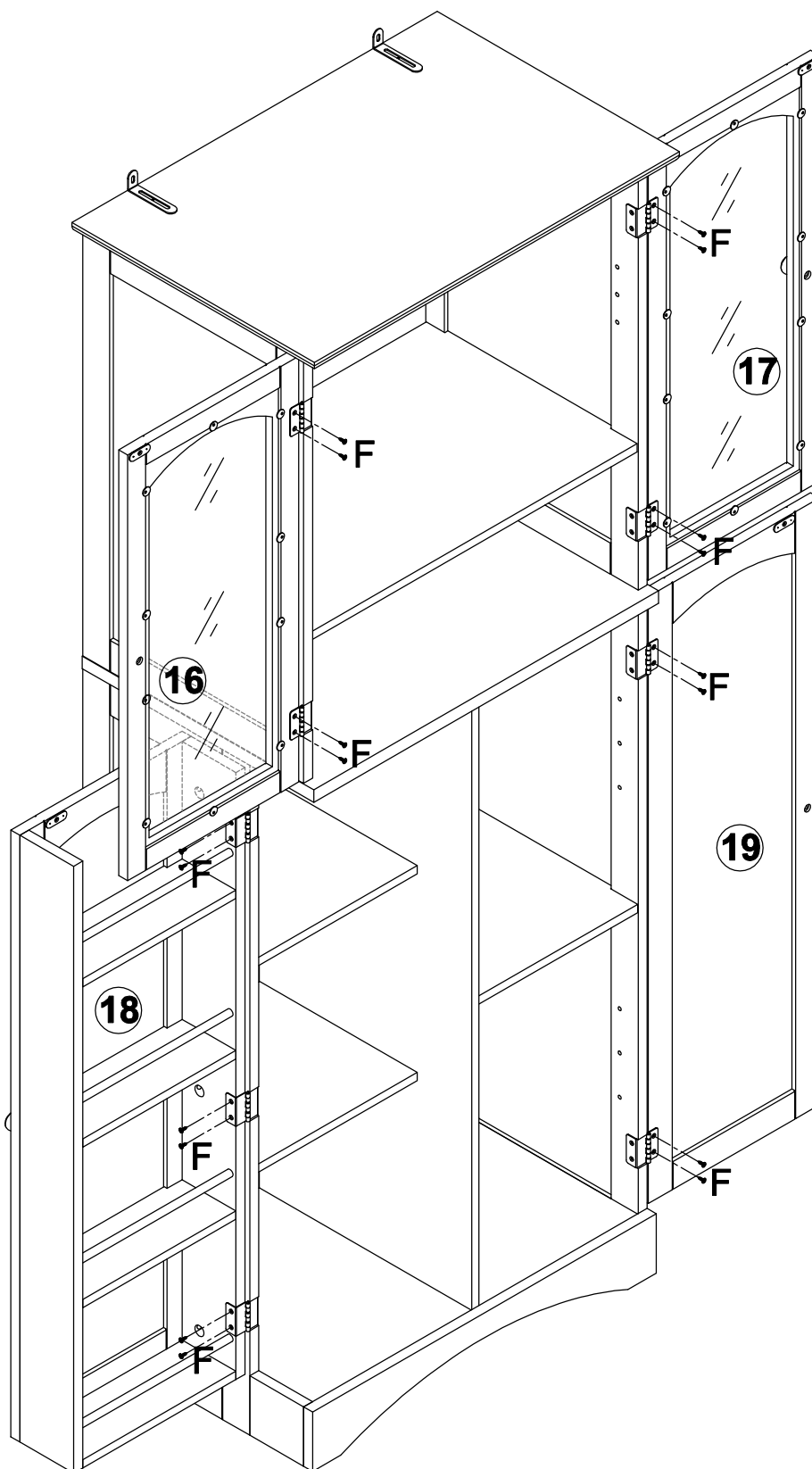

Step 31

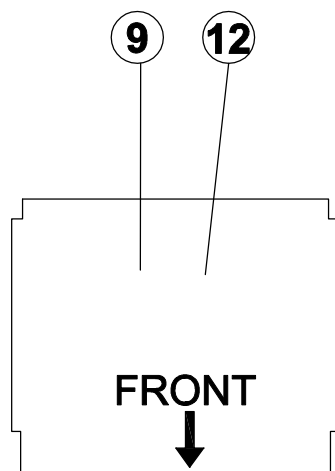
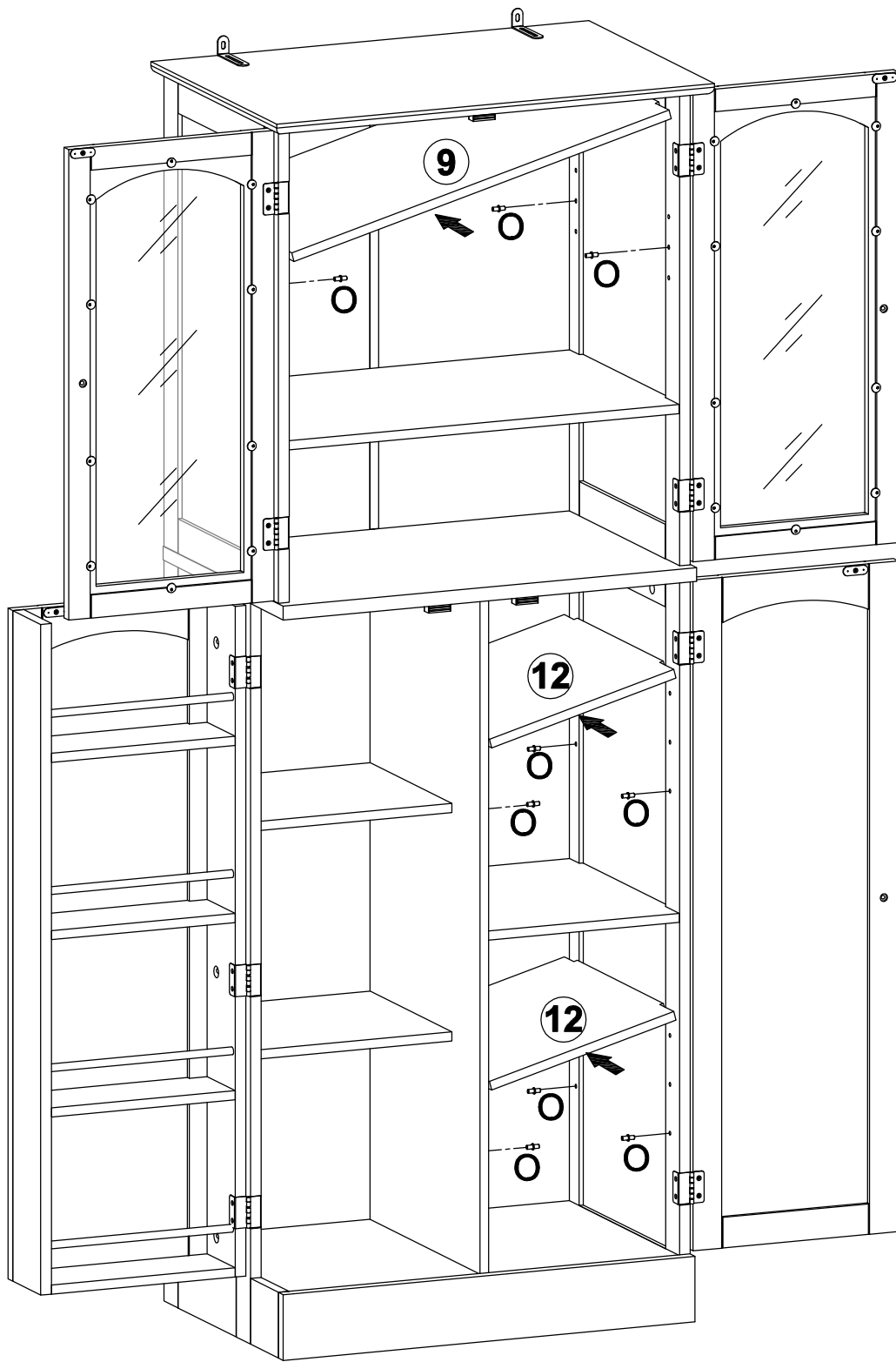
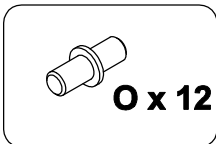
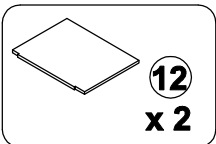
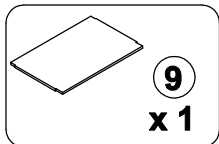

Step 32

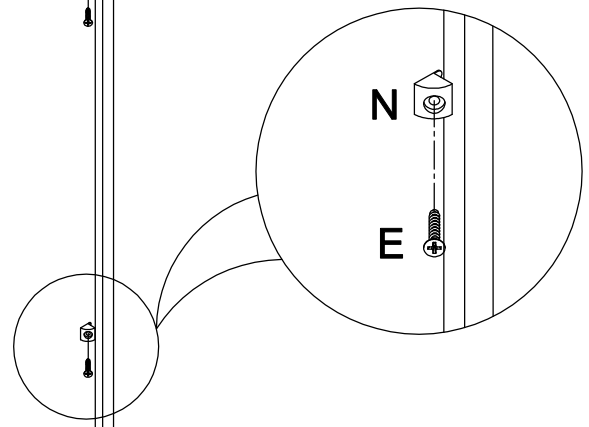
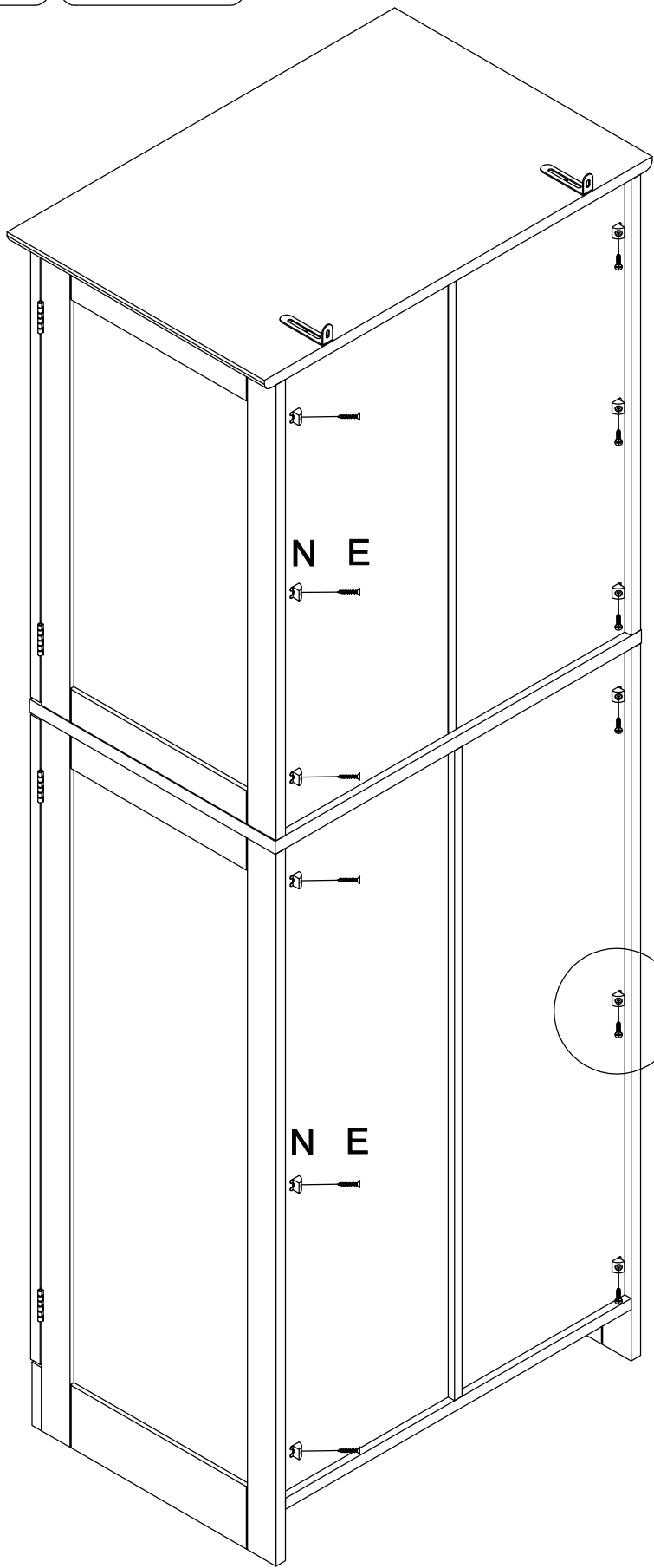
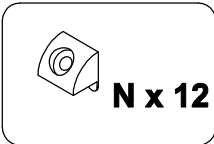

Step 33

