

|Sofa

V1.0

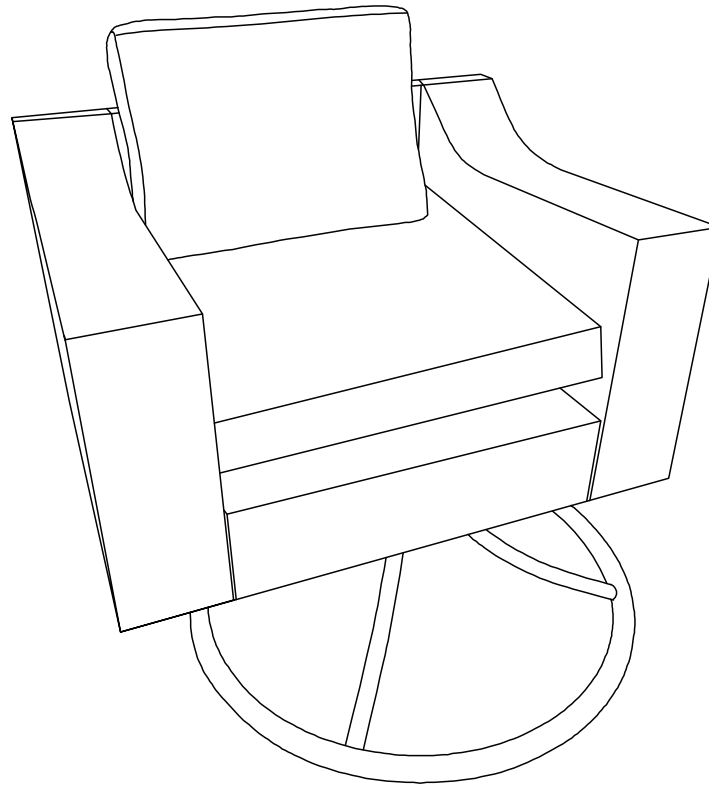

Assembly Instruction – Please keep properly for future reference.

If you find any missing boxes, damaged parts, or accessory shortages, please contact the customer service team of your purchasing channel immediately. We will resolve the issue as quickly as possible.

CONTACT US

- In order to receive assistance more quickly, please provide

THE FOLLOWING INFORMATION:

- Order number
- Purchase platform
- Purchase date
- Detailed description of the issue along with photos (if applicable)

Important – Please read these instructions carefully before starting the installation.

EN

CUSTOMER SERVICE GUIDE

Thank you for choosing our product! We are committed to providing you with excellent service. If you find any missing parts, damaged packaging, or product damage after receiving all packages, please follow the steps below to quickly contact our customer service team. We will do our best to resolve your issue.

1. Missing Parts

Verify Parts:

1. Refer to the “Parts List” in the manual to verify the name, specifications, and quantity of the missing parts.
2. Take a clear photo of the parts list and mark the missing parts with detailed information, e.g., “Missing 5 pieces of M6x30mm screws.”

Contact Us:

· By Email:

Send an email with the subject line “Missing Parts Issue.” Include the following in the email:

- A description of the missing parts and a photo of the parts list.
- Order details (order number, purchase platform, purchase date).

2. Product or Packaging Damage

If it affects normal use:

Steps:

1. Take clear photos or videos showing the damaged parts and the extent of the damage (multi-angle shots are recommended).
2. Email the photos/videos along with other details with the subject line “Product Damage Issue.”

Resolution:

After verification, we will arrange for a replacement part, product exchange, or refund as quickly as possible.

If it does not affect normal use:

Steps:

1. Contact our customer service team.
2. Provide a description of the damage and include relevant photos or videos.

Resolution:

We will provide repair guidance or an appropriate compensation plan based on the specific situation.

Helpful Tips

To process your issue efficiently, please prepare the following information:



- Order details (order number, purchase platform, purchase date).
- Clear photos or videos.
- We are committed to providing quick and professional solutions, no matter the size of the issue, to ensure your satisfaction.

Thank you for your trust and support! We hope you enjoy using our product!

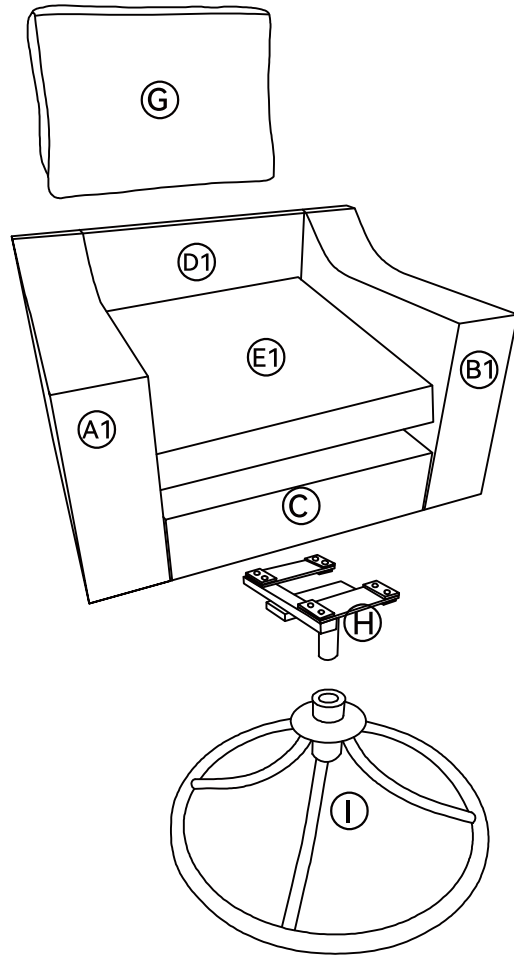



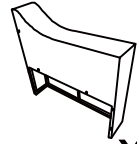
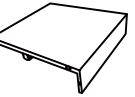

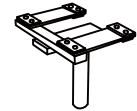
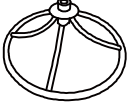
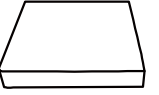

Sofa

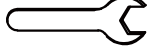
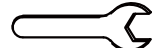

Main structure accessories

<p>(A1) Right Armrests</p>  <p>x1</p>	<p>(B1) Left Armrests</p>  <p>x1</p>	<p>(C) Seat</p>  <p>x1</p>	<p>(D1) Back rest</p>  <p>x1</p>
<p>(G) Back cushion</p>  <p>x1</p>	<p>(H) T'-base</p>  <p>x1</p>	<p>(I) Seat base</p>  <p>x1</p>	<p>(E1) Seat cushion</p>  <p>x1</p>



Hardware parts

<p>① Bolt</p>  <p>M6x35</p> <p>x4</p>	<p>② Washer</p>  <p>x10</p>	<p>③ Allen Key</p>  <p>x1</p>	<p>④ Spanner</p>  <p>x1</p>
<p>⑤ Spanner</p>  <p>x1</p>	<p>⑥ Bolt</p>  <p>M8x45</p> <p>x4</p>	<p>⑦ Nut</p>  <p>M8</p> <p>x4</p>	<p>⑧ Elastic Gasket</p>  <p>x4</p>
<p>⑨ Iron Piece</p>  <p>x4</p>	<p>⑩ Bolt</p>  <p>M6x40</p> <p>x6</p>	<p>⑭ Adjust hinge</p>  <p>x5</p>	

Assembly Instruction

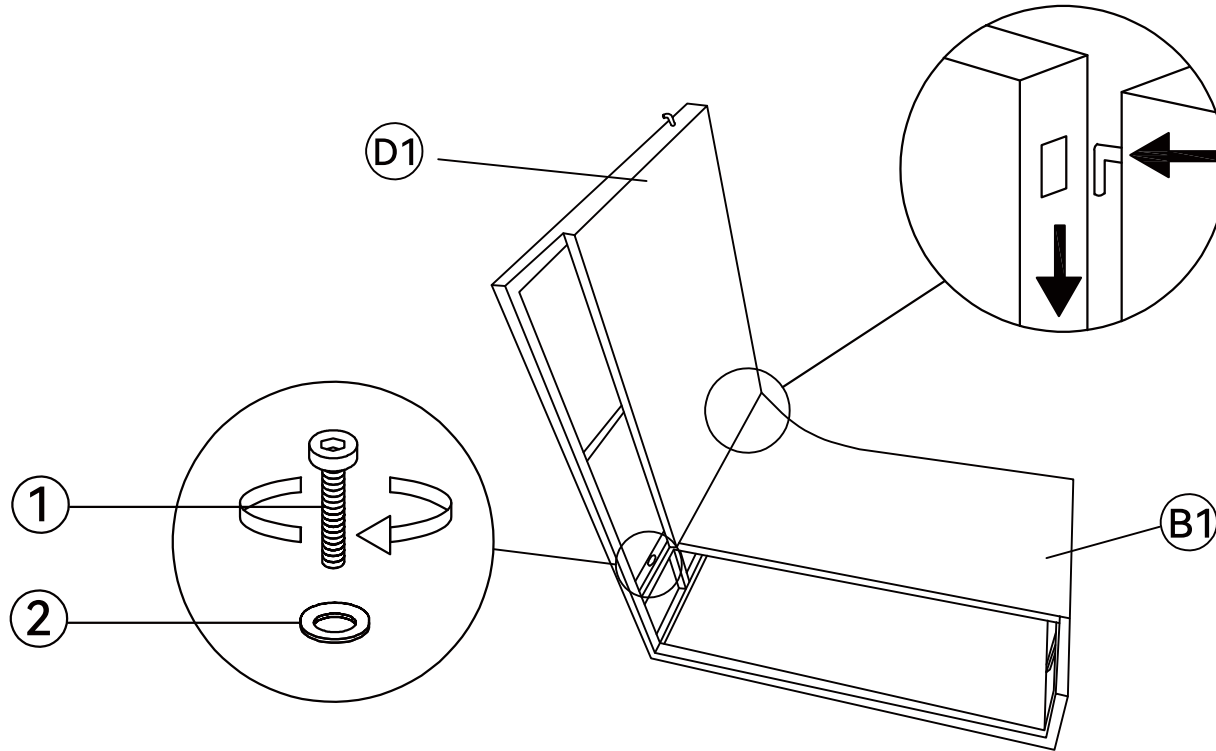
STEP 1







(B1) Left Armrests  x1	(D1) Back rest  x1	(1) Bolt M6x35 x1	(2) Washer  x1
---	---	-------------------------	---

Before assembly, place the armrest on the floor. First attach the hook to position (B1), then proceed with assembly. Use screw (1) and washer (2) to connect part (D1) to part (B1). Do not fully tighten the screw(s).

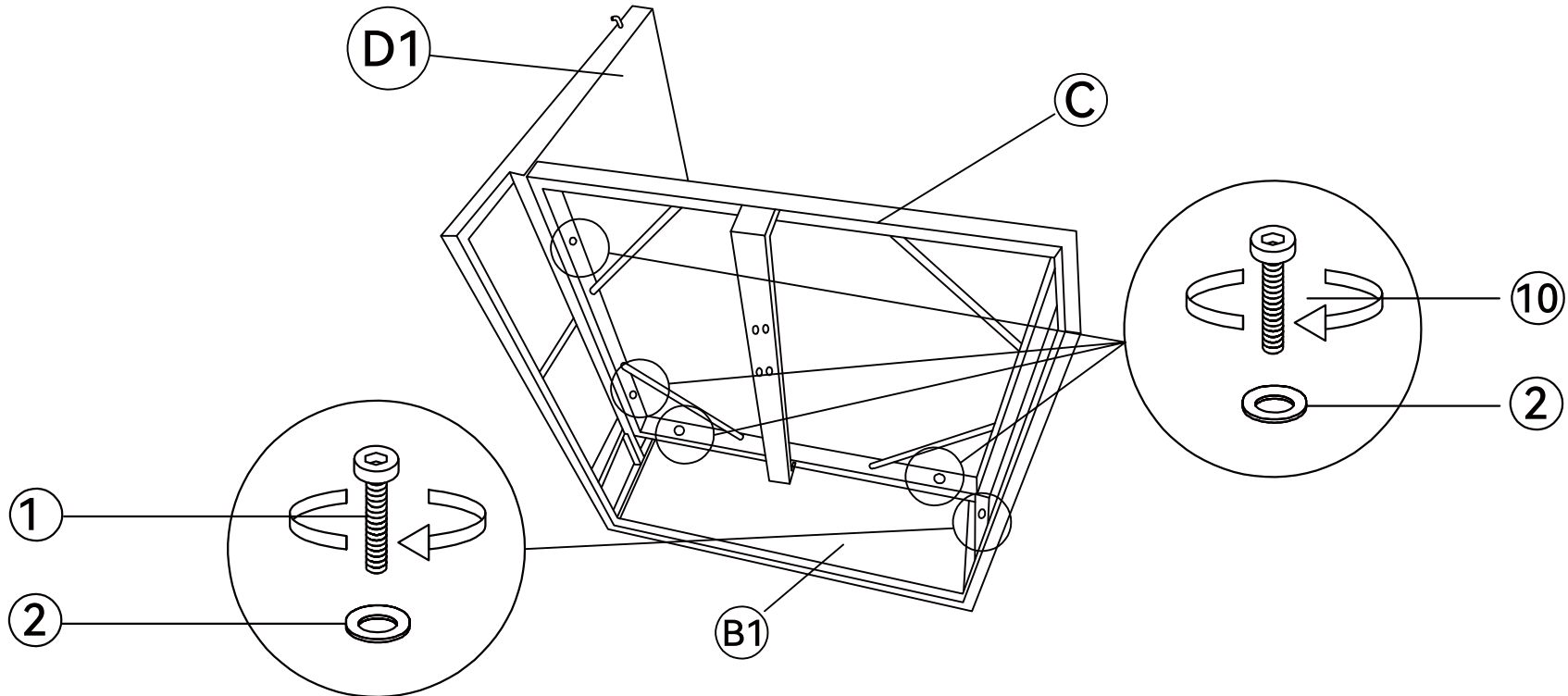
Assembly Instruction

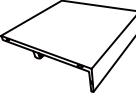
STEP 2







Ⓒ Seat	① Bolt	⑩ Bolt	② Washer
			
x1	M6x35 x1	M6x40 x4	x5

Use screw (1) and washer (2) to connect part (D1), part (B1), and part (C).

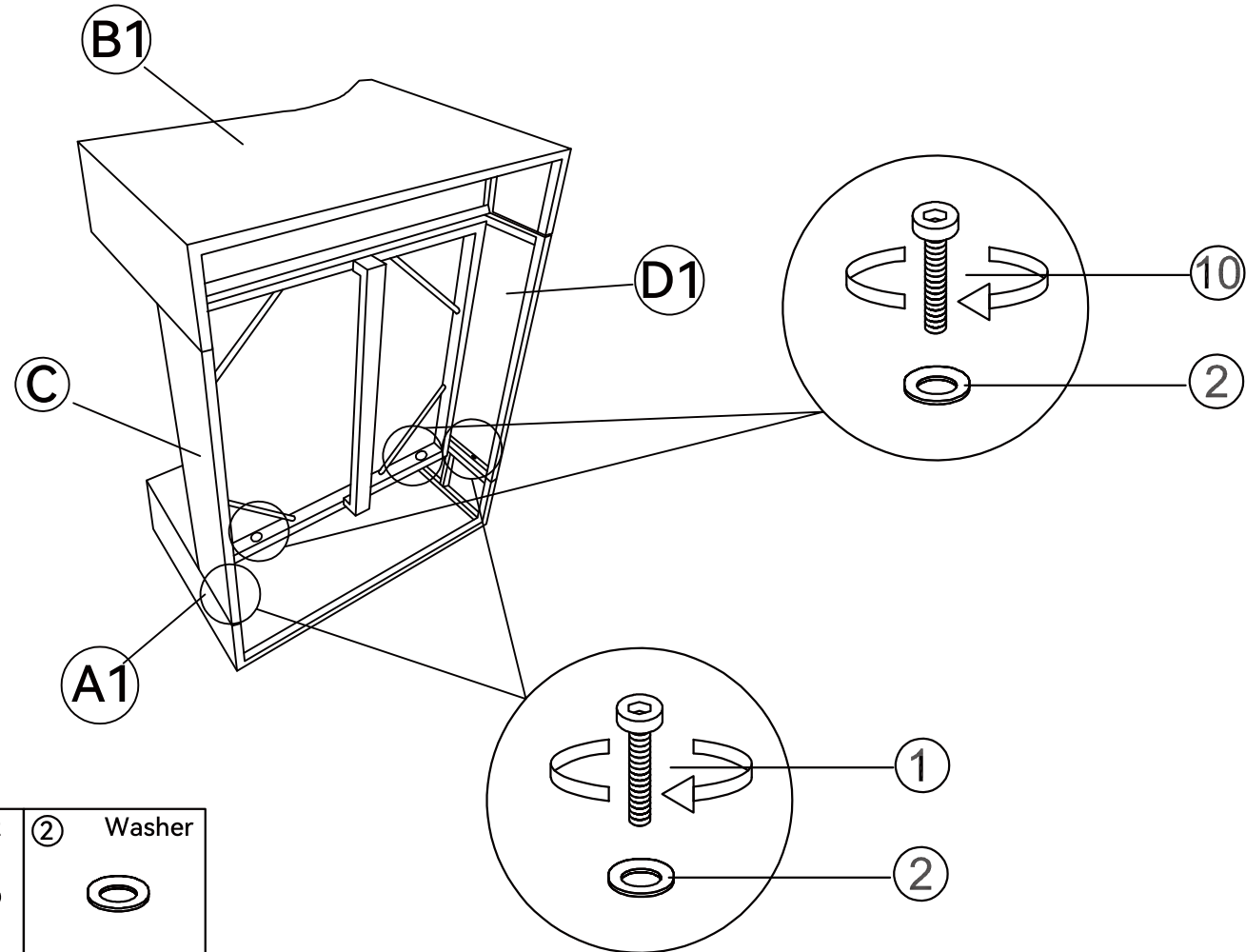
Assembly Instruction

STEP 3



 A1 Right Armrests x1	 1 Bolt M6x35 x2	 10 Bolt M6x40 x2	 2 Washer x4
--	--	---	---

Use screw (10), screw (1), and washer (2) to connect part (D1), part (A1), and part (C).
Tighten all screws securely.

Assembly Instruction

STEP 4

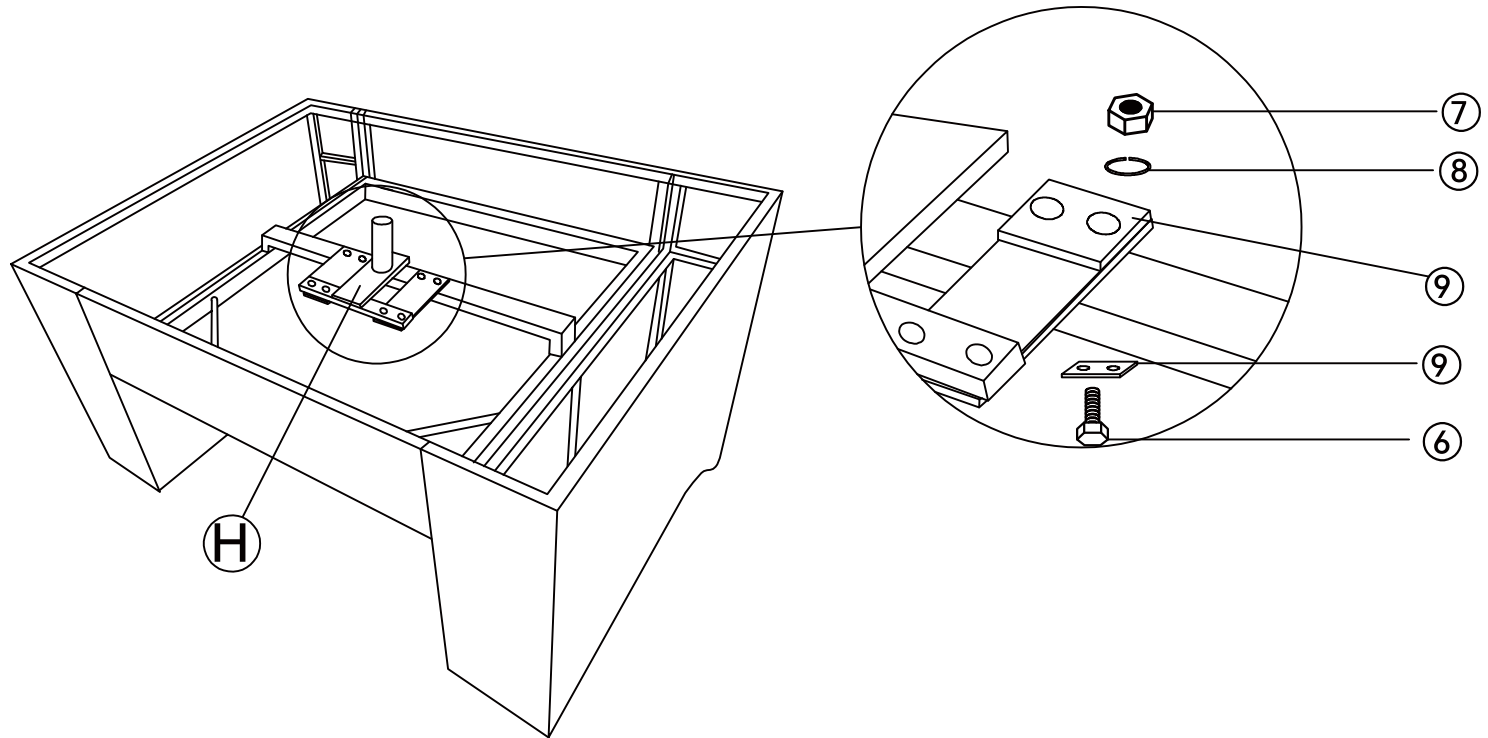



⑥ Bolt M8x45 x4	⑦ Nut M8 x4	⑧ Elastic Gasket x4	⑨ Iron Piece x4	④ Spanner x1	⑤ Spanner x1	Ⓜ 'T'-base x1
-----------------------	-------------------	------------------------	--------------------	-----------------	-----------------	------------------

Use screw (6), metal plate (9), spring washer (8), and nut (7) to connect part (H) and part (C).

Assembly Instruction

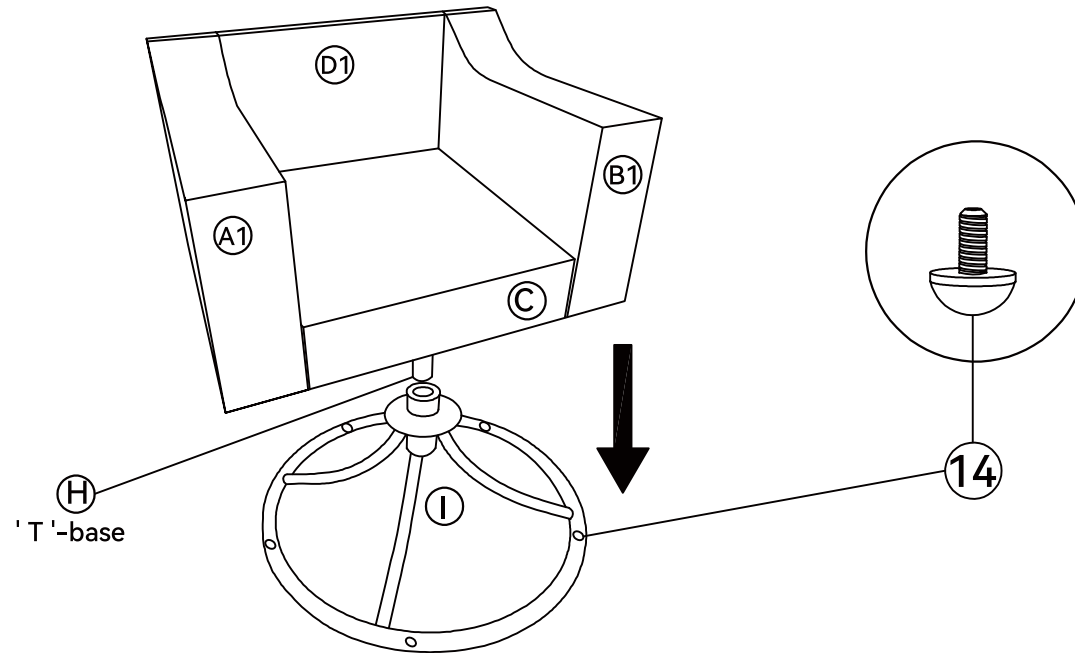
STEP 5

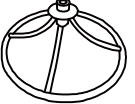

<p>① Seat base</p>  <p>x1</p>	<p>⑭ Adjust hinge</p>  <p>x5</p>
--	---

Insert part (I) into part (H) to connect them. Insert part (14) into the position indicated in the illustration to complete the connection.

Assembly Instruction

STEP 6

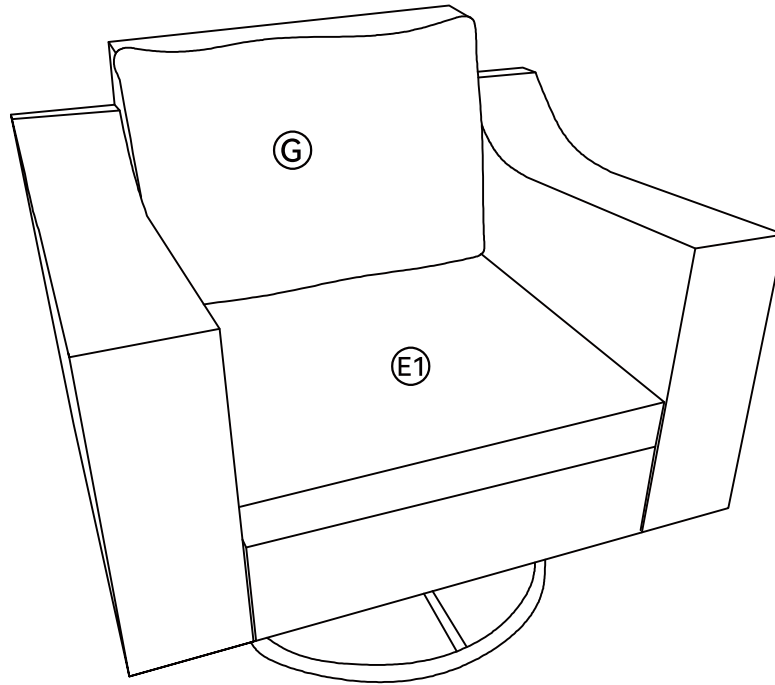

(E1) Seat cushion

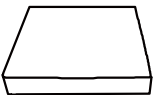

x1

(G) Back cushion



x1

Adjust the foot pads to ensure stability. Assembly is complete.