

Owner Manual

Always exceed your expectations

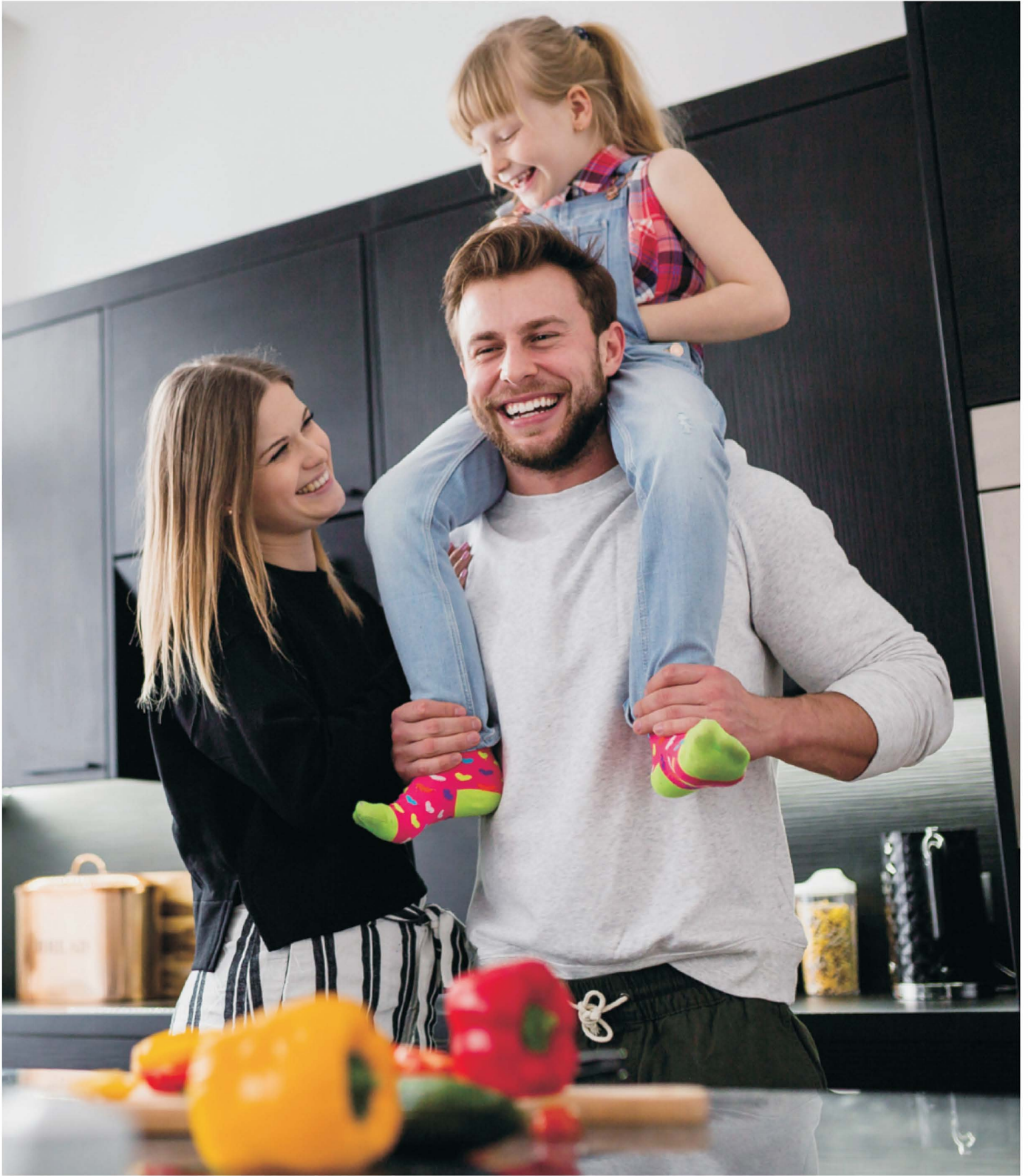

ACCENT SWIVEL CHAIR USER GUIDE



Always exceed your expectations

We brings the trendy and comfortable furniture accessible to everyone on every budget.

We work directly with our manufacturers to produce unique, durable pieces using high-quality materials.

This direct relationship means we can bring you stylish and appealing furniture at unrivaled value.

With fast & free delivery, you can create a beautiful home in a snap.

We're glad you're here. Thanks for choosing .





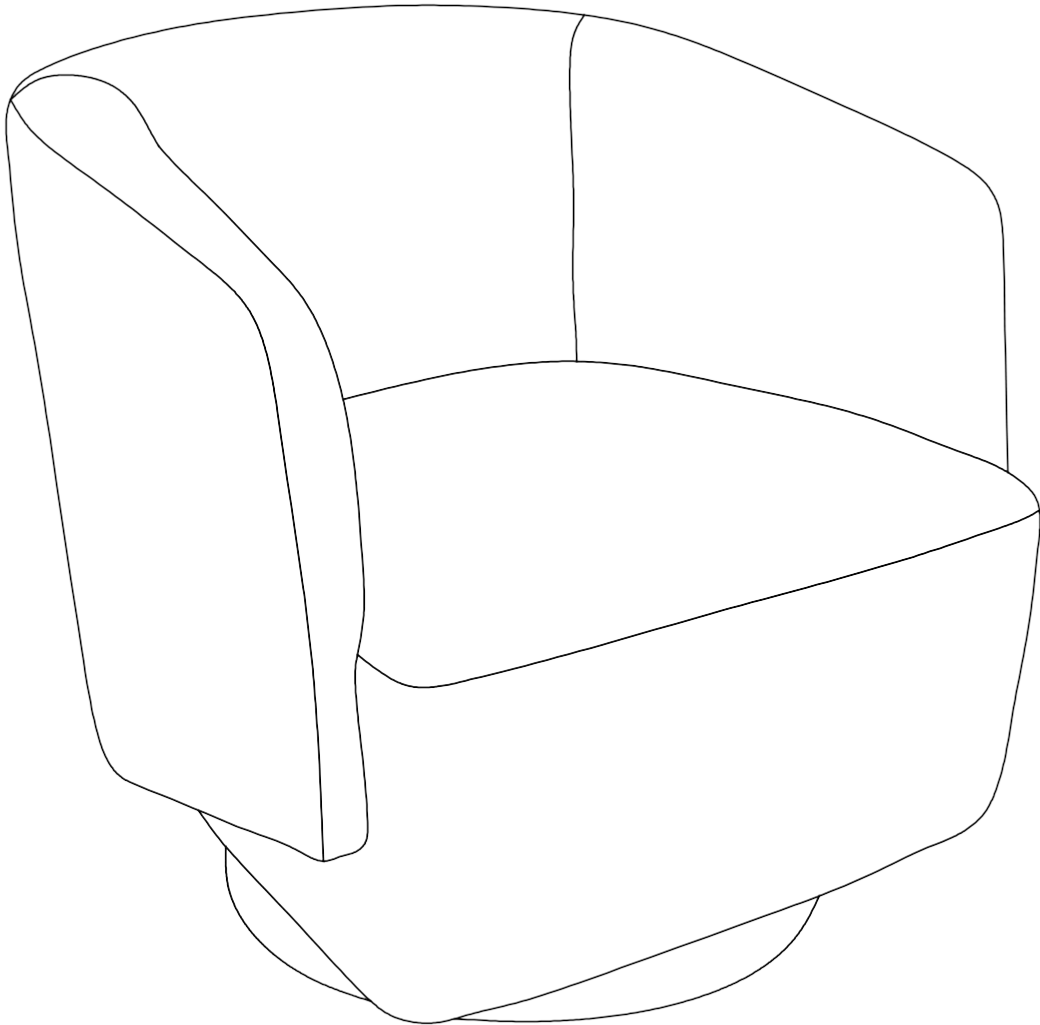

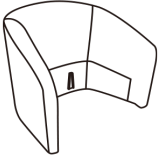
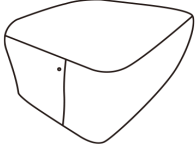

Assembly Manual

Accent Swivel Chair

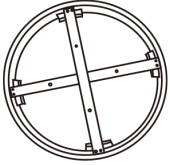

⚠ CAUTION

THIS ASSEMBLY MANUAL CONTAINS IMPORTANT SAFETY INFORMATION.
PLEASE READ AND KEEP FOR FUTURE REFERENCE.

<p>Ax1</p> 	<p>Bx1</p> 	<p>Cx1</p> 
<p>Dx1</p> 	<p>Ex2</p> 	<p>Fx12</p>  <p>M6*30mm</p>
<p>Gx2</p>  <p>M6*50mm</p>	<p>Hx2</p>  <p>M8*22mm</p>	<p>Ix1</p> 

INSTRUCTION

- 1 Attach Swivel mechanism (C) to Solid wood swivel base (D) with Bolts (F) and Allen wrench (I).

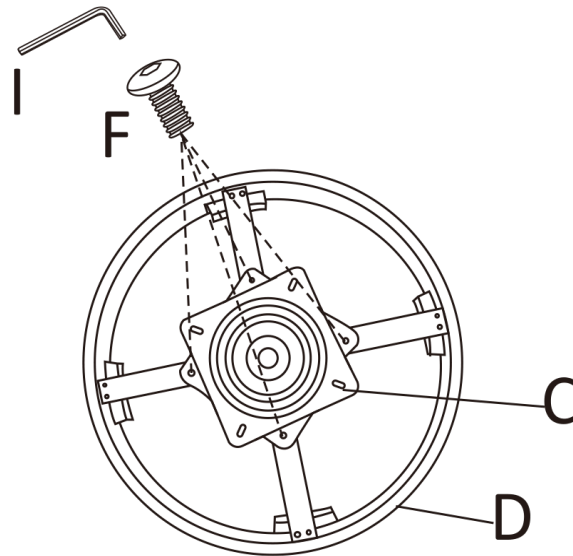

- 2 Attach Slots (E) to Chair seat (B) with Bolts (F) and Allen wrench (I).

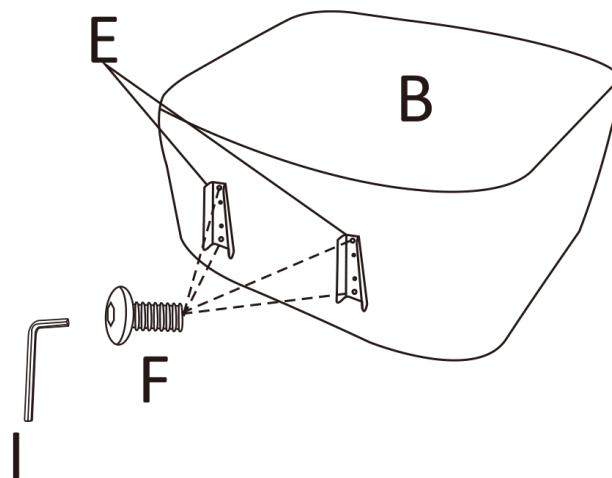

INSTRUCTION

- 3 Align and Slide the slots on Chair Back (A) into Chair seat (B).

Note: Press down firmly to make sure all the slots align firmly.

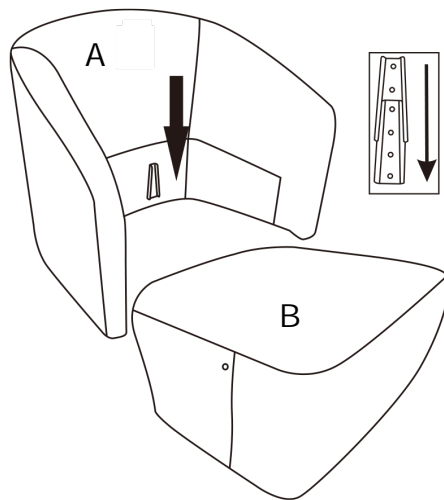

- 4 Firmly attach the Chair back (A) to Chair base (B) with Washers (H), Bolts (G) and Allen wrench (I).

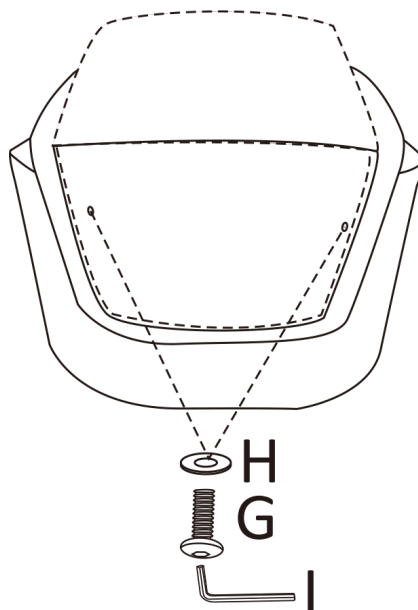

INSTRUCTION

- 5 Attach the assembled swivel base in Step One to the Chair body (assembled in Step Four), using Bolts (F) and Allen wrench (I).

Note: Firmly attached all the bolts.

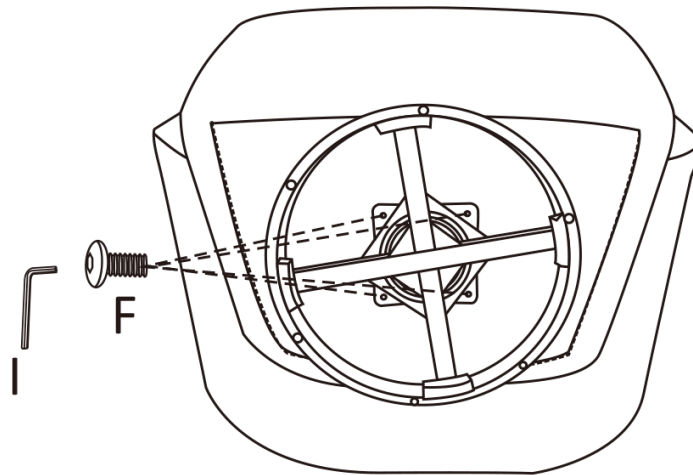

- 6 Assembly complete. Enjoy.

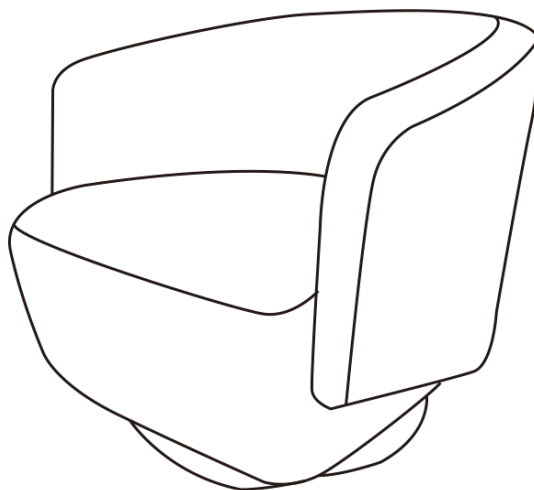

RETURN POLICY

- 30-day return policy
- 1 Year Warranty

30-DAY RETURN POLICY

We have a 30-day return policy, which means you have 30 days after receiving your item to request a return.

If you are not completely satisfied with your purchase, please contact customer service. All our products are subject to a 30 day return period from the date of original delivery.

RETURN REQUEST

1. Your item must (need to) be in the same condition as you received it, unworn or unused, with tags and original packaging.
2. Please inspect your item when you receive it. If the item is defective, damaged or you have received the wrong item please contact us immediately so that we can assess the problem and rectify it.
3. Please pack the item in our original packaging and take a photo to confirm with us. If the item has not been opened please take a photo of the packaging.
4. Use only the return shipping label we sent you.
5. Only use the return address we provide.
6. We do not accept items sent back to us without contacting customer service.
7. Unfortunately, we do not accept returns for special offers or gift cards. If you have any questions or concerns about a specific item please contact us.

RETURN PROCESS

1. Please contact your customer service and provide your order number, reason for return and a photo of the item.
2. Please pack the item in our original packaging and take a photo to confirm with us. If the item is not opened, please take a photo of the packaging.
3. Customer service will contact you within 48 hours. If the return request is approved we will send you a return label.
4. We will notify you once we have received and inspected your return and let you know if the refund has been approved. If approved you will automatically receive a refund via the original payment method.
5. Please note that it may also take 1-3 working days for your bank or credit card company to process and post the refund.
Refunds are expected to be processed within 1-4 working days.

1 YEAR WARRANTY

We offer a 1 year free warranty. So if your item arrives damaged (even from the shipping company) please inform us immediately. We will need pictures or video (we need pictures or video to confirm the condition of the item) to assist you with replacement parts, replacement items (subject to availability) or a full refund. 1 Year Warranty

CARE & MAINTENANCE

- Water Based Cleaner 'W' : Spot clean using the foam only from a water-based cleaning agent such as a mild detergent or non-solvent upholstery shampoo product. Apply foam with a soft in circular motion. Vacuum when dry.
- Do not place furniture in direct sunlight and keep furniture at least 60 cm / 2 feet from heat sources to avoid fading.