

ASSEMBLY INSTRUCTIONS

Wall Cabinet w/2Doors

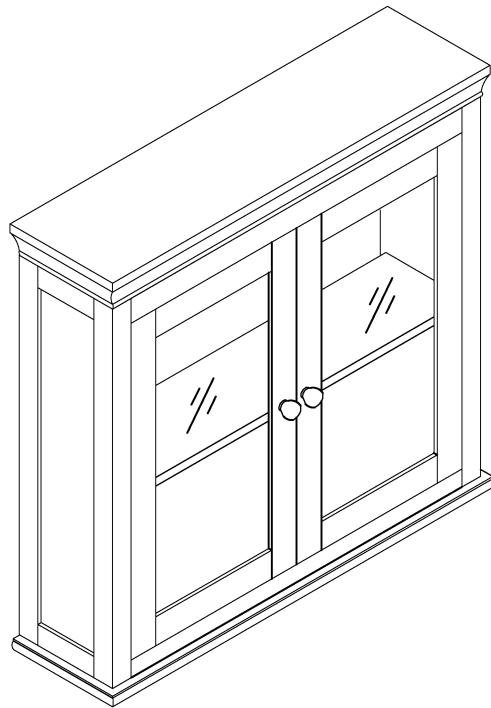

Please provide the following information when contacting for parts or questions: the name of the company you purchased from, the UPS/FedEx tracking number.

This product comes with a 1 year warranty. Products purchased second hand/used are not covered under the warranty.

ASSEMBLY INSTRUCTIONS-IMPORTANT

Carefully unpack & identify each component before attempting to assemble. Refer to parts list. Please take care when assembling the unit and always set the parts on a clean,soft surface. If you require any assistance with assembly,parts,please call the company you place order with or please email us.

INSTRUCCIONES PARA ARMAR-IMPORANT:







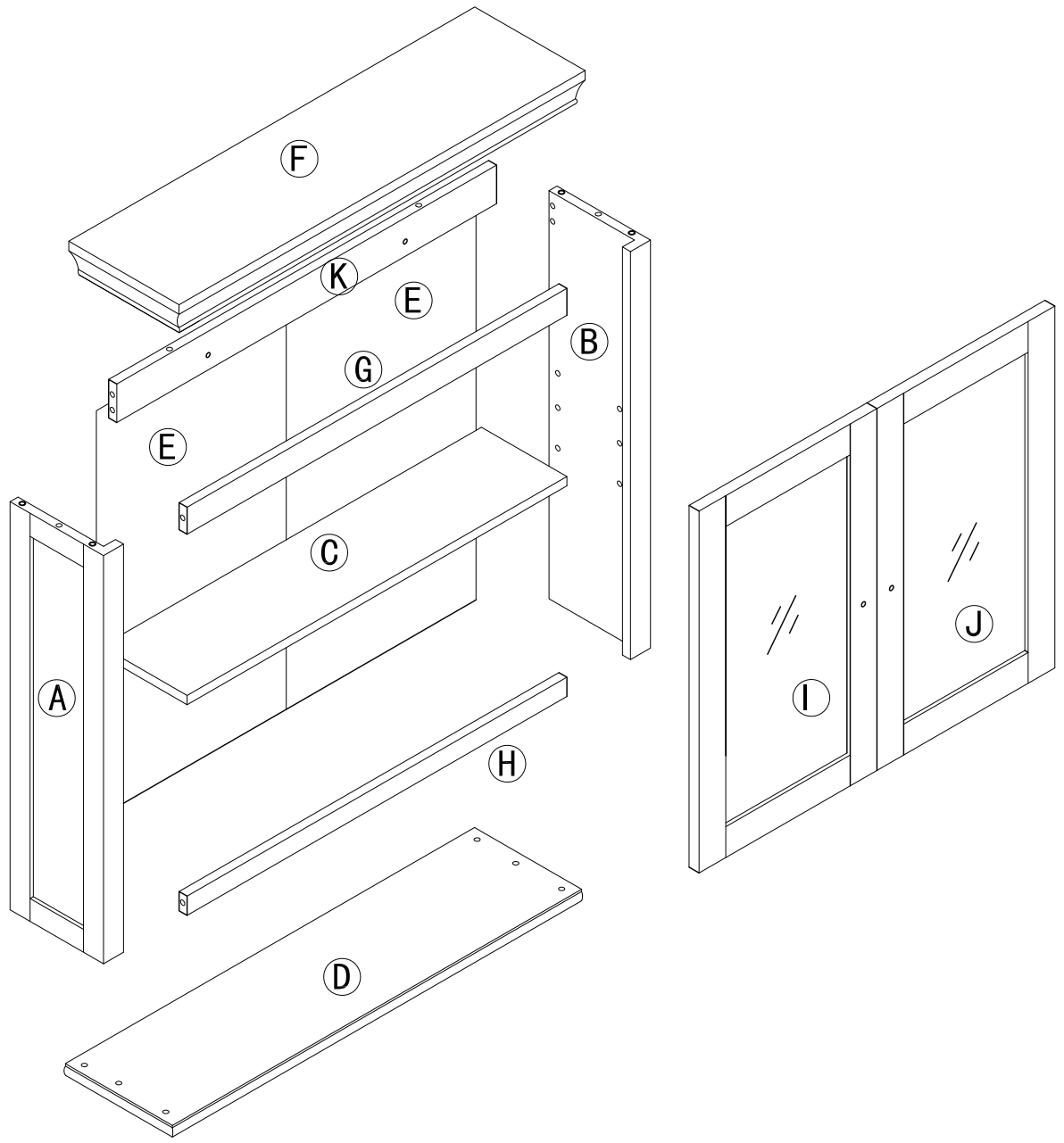

Desempaque e identifique cuidadosamente cada componente antes de intentar ensamblar. Consulte la lista de piezas. Tenga cuidado al ensamblar la unidad y siempre coloque las piezas en una superficie limpia y suave. Si necesita ayuda con el ensamblaje, piezas, llame a la compañía con la que realiza el pedido o envíenos un correo electrónico.

DIRECTIVES DE MONTAGE-IMPORTANT:



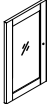
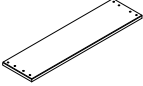



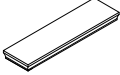

Déballez et identifiez soigneusement chaque composant avant d'essayer de l'assembler. Se référer à la liste des pièces. Veuillez faire attention lors du montage de l'appareil et placez toujours les pièces sur une surface propre et douce. Si vous avez besoin d'aide pour l'assemblage, les pièces, veuillez contacter la société avec laquelle vous passez la commande ou envoyez-nous un e-mail.

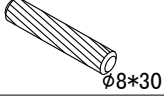
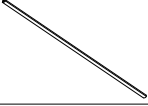
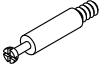
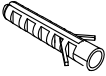
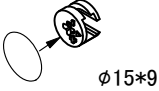

COMPONENTS

PART	FIGURE	DESCRIPTION	QTY	PART	FIGURE	DESCRIPTION	QTY
A		LEFT SIDE PANEL	1PC	G		UPPER RAIL	1PC
B		RIGHT SIDE PANEL	1PC	H		BOTTOM RAIL	1PC
C		ADJUSTABLE SHELF	1PC	I		LEFT DOOR	1PC
D		BOTTOM PANEL	1PC	J		RIGHT DOOR	1PC
E		BACK PANEL	2PCS	K		UPPER BACK RAIL	1PC
F		TOP PANEL	1PC				

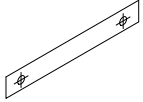
HARDWARE & TOOLS

PART	FIGURE	DESCRIPTION	QTY	PART	FIGURE	DESCRIPTION	QTY
1		WOODEN DOWEL	14PCS	9		PLASTIC BAR	1PC
2		CAM BOLT	8PCS	10		ANCHOR	2PCS
3		CAM LOCK	8PCS	11		SCREW	2PCS
5		SCREW	8PCS	12		SCREW	14PCS
6		KNOB	2PCS	13		SCREW	1PC
7		KNOB BOLT	2PCS			TEMPLATE PAPER	
8		SHELF PIN	4PCS				

TOOL NEEDED:



**PHILIPS SCREWDRIVER REQUIRED
- NOT INCLUDED**

SUGGESTION:



TWO PEOPLE FOR ASSEMBLING



WARNINGS:

1. DO NOT LET ANY SHARP OBJECTS TOUCH OR RUB THE SURFACE OF THE PRODUCT.
2. WHEN ASSEMBLING, DO NOT LET CHILDREN PLAY AROUND THE WORKING AREA.
3. PLEASE CONFIRM ALL PARTS ARE CORRECT BEFORE STARTING THE ASSEMBLY PROCESS.
4. DO NOT TIGHTEN ALL BOLTS AND SCREWS COMPLETELY UNTIL THE ENTIRE UNIT HAS BEEN ASSEMBLED AND SET UP.

1



10 PCS

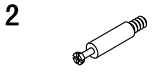

4 PCS

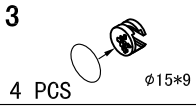

4 PCS $\phi 15 \times 9$

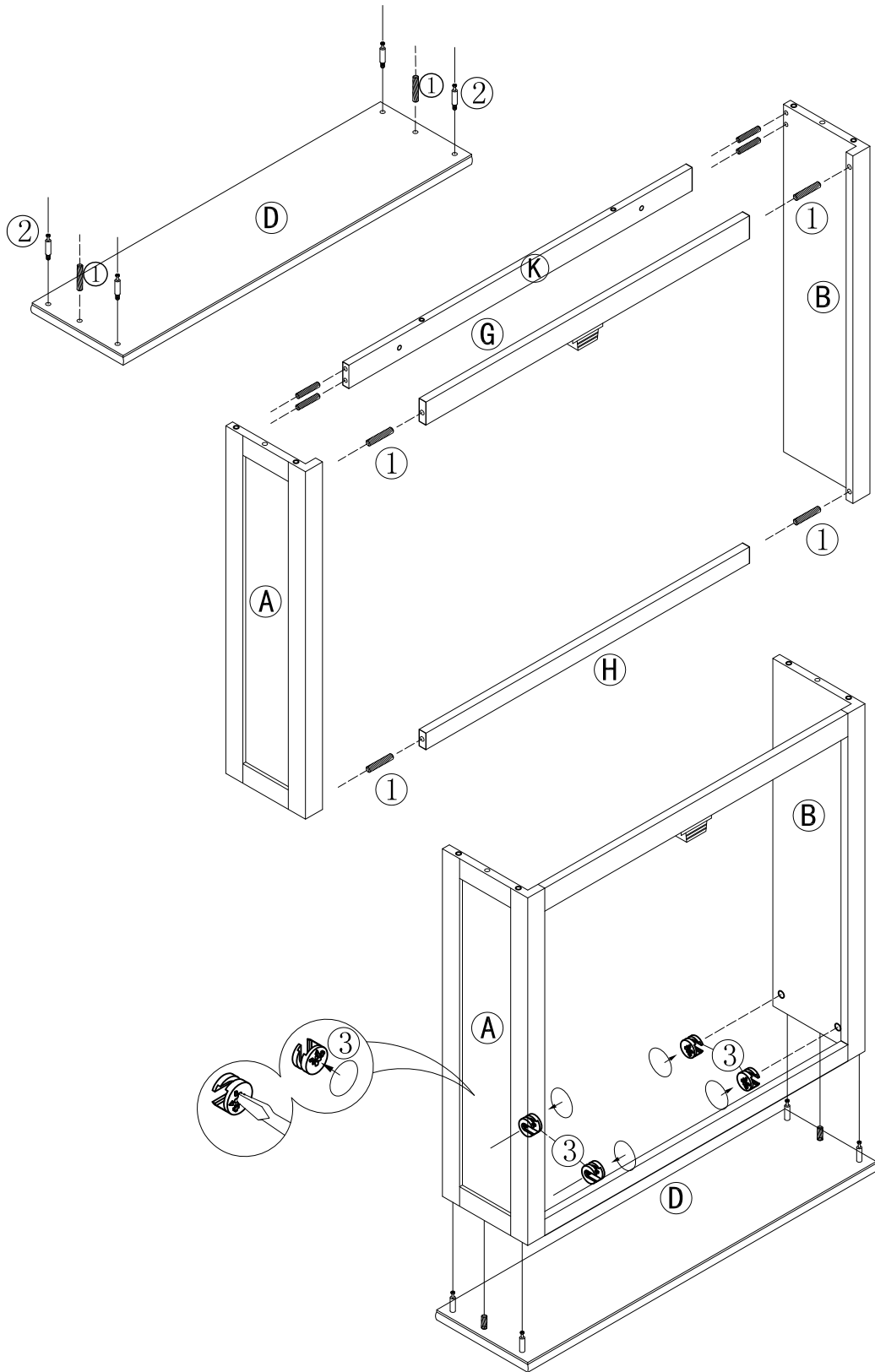

STEP 1:

1. Screw cambolts (2) and insert dowels (1) to panel D.
2. Attach rails G, H, & K to panels A & B with dowels (1).
3. Attach panel D to panels A & B & secure with camlocks (3).

2



4 PCS

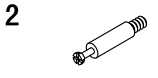

4 PCS

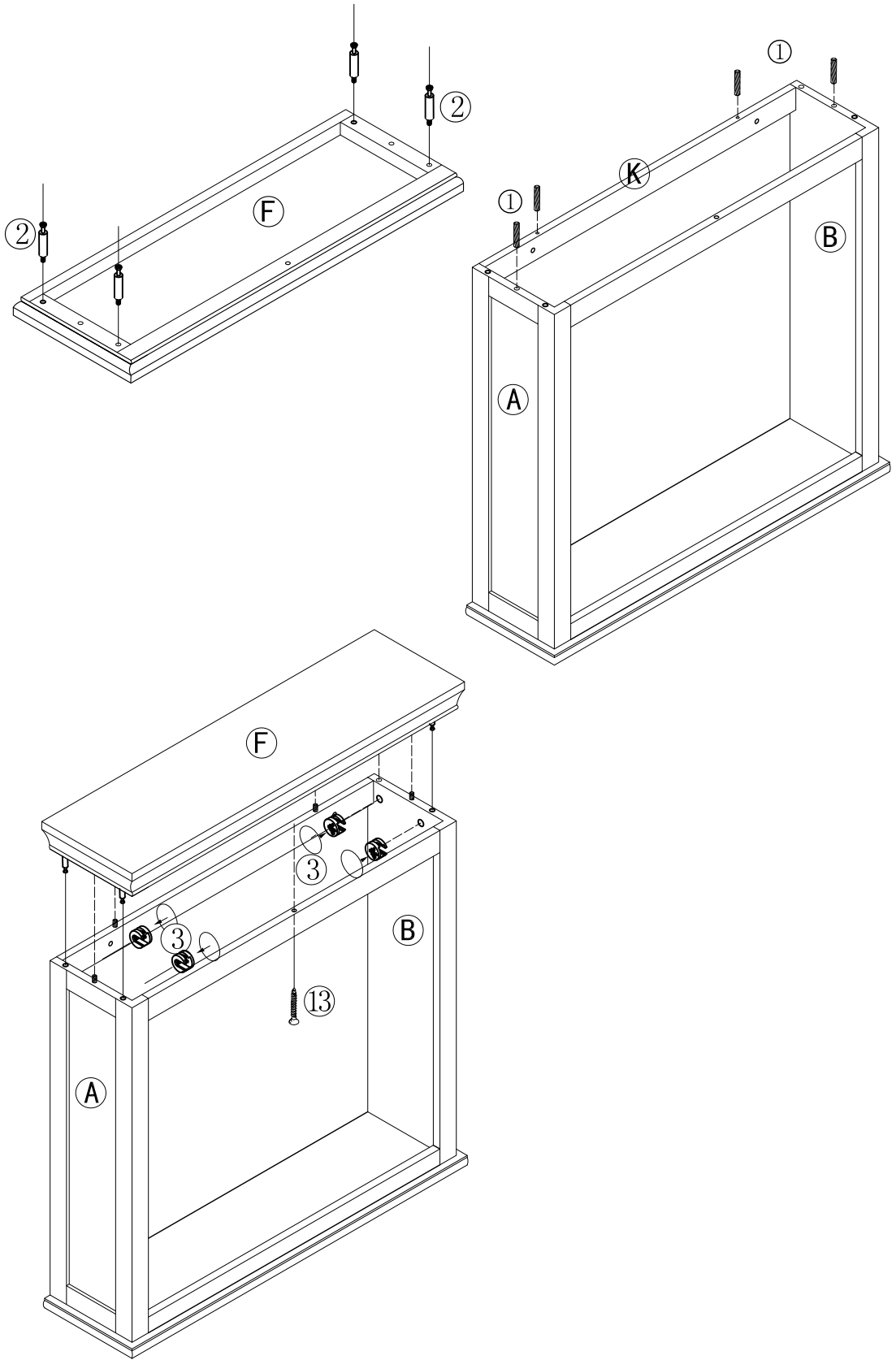
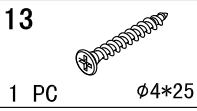
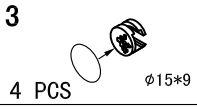

STEP 2:

1. Screw cambolts (2) to panel F.
2. Insert dowels (1) to the top of panels A & B and rail K.
3. Attach panel F to panels A & B & secure with camlocks (3) and screw (13).

3

12



14 PCS $\phi 3 \times 12$ D=7

9



1 PC

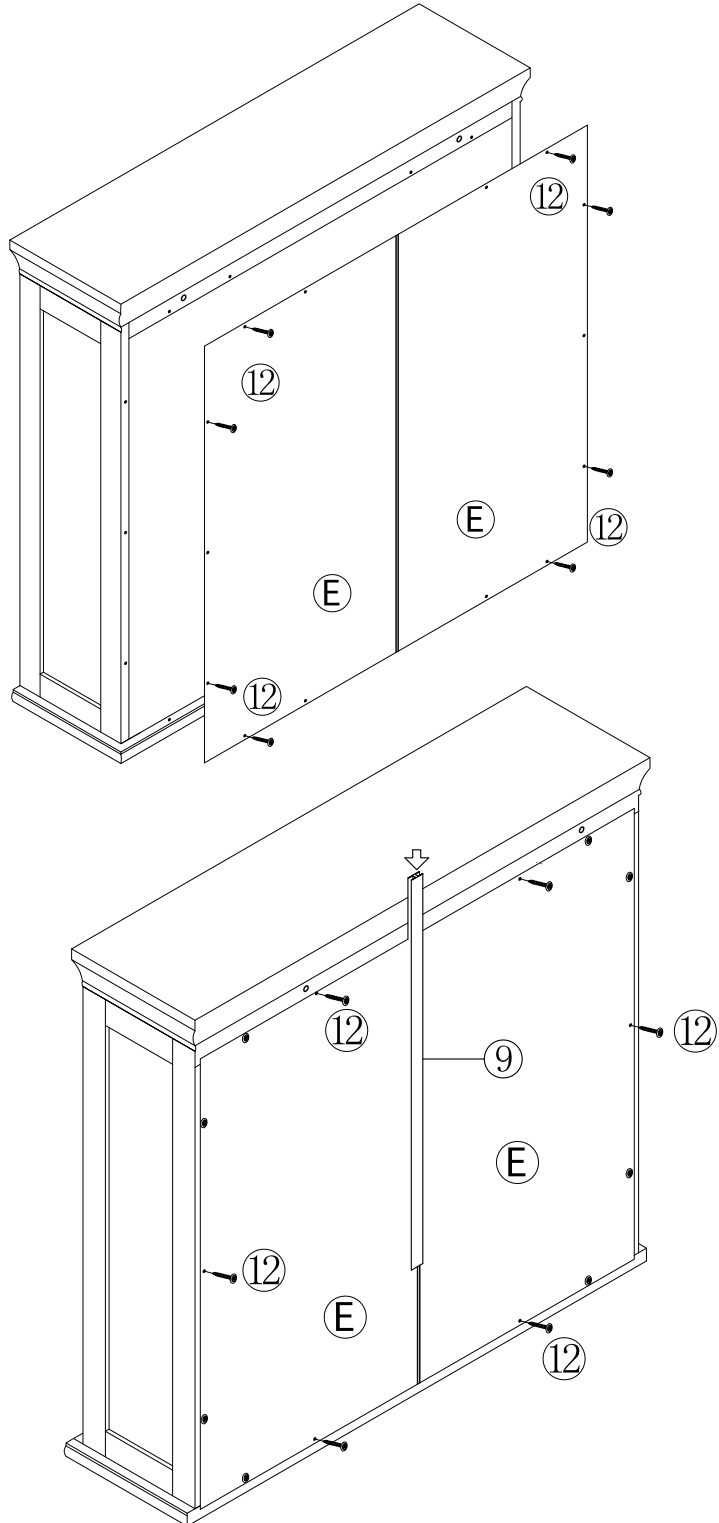

STEP 3:

1. Attach panels E to the back of the cabinet & secure the four corners with screws (12).
2. Insert plastic bar between the two panel Es and finish securing the panels with screw (12).

4

5

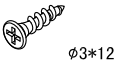

8 PCS

6



2 PCS

7



2 PCS

8



4 PCS

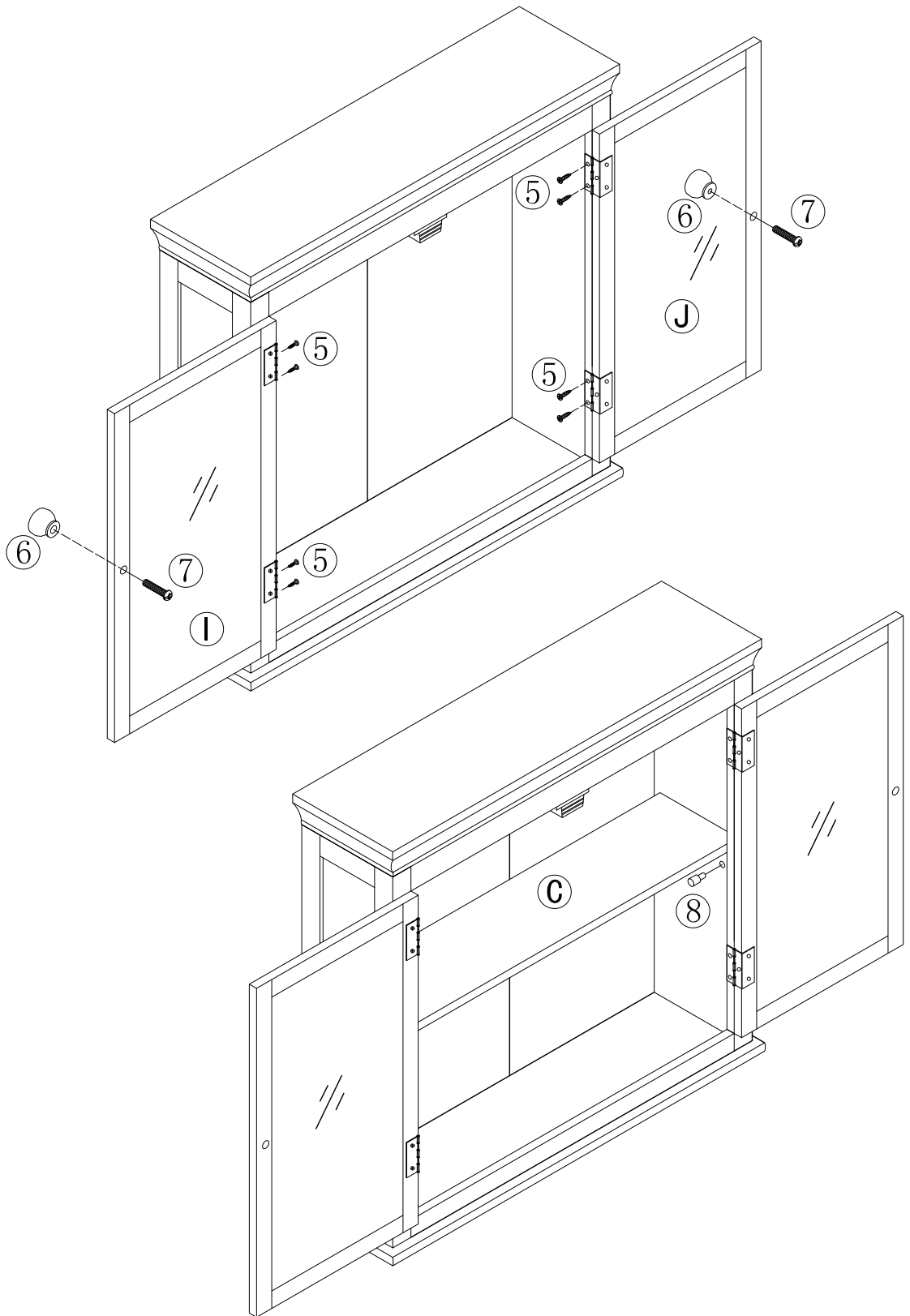

STEP 4:

1. Attach knobs (6) to doors I & J with bolts (7).
2. Attach doors I & J with screws (5).
3. Insert shelf pins (8) in panels A & B and rest the adjustable shelf on the shelf pins.

5

10



2 PCS

11



2 PCS $\phi 4 \times 35$

