

ASSEMBLY INSTRUCTIONS

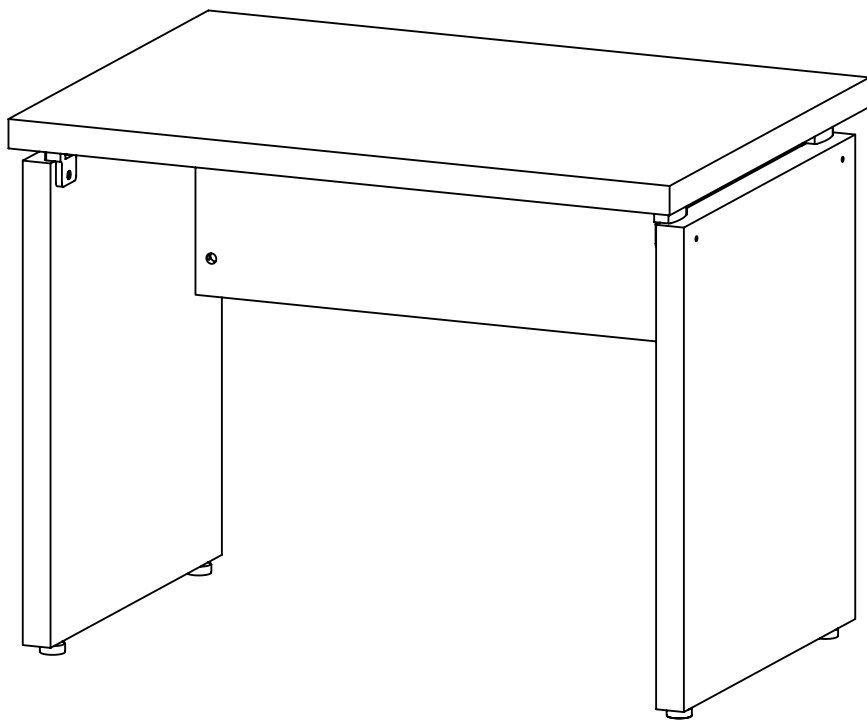

***DESK
RETURN***

ASSEMBLY INSTRUCTIONS

ASSEMBLY TIPS:

1. Remove hardware from box and sort by size.
2. Please check to see that all hardware and parts are present prior to start of assembly.
3. Please follow attached instructions in the same sequence as numbered to assure fast & easy assembly.



WARNING!

1. Don't attempt to repair or modify parts that are broken or defective. Please contact the store immediately.
2. This product is for home use only and not intended for commercial establishments.



ASSEMBLY TIME





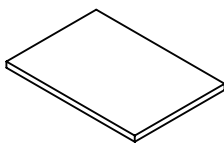
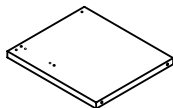
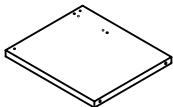
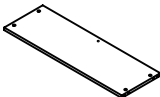





20 MINUTES

PARTS IDENTIFICATION

A	TOP PANEL		1 PC	C	RIGHT SIDE PANEL		1 PC
B	LEFT SIDE PANEL		1 PC	D	BACK PANEL		1 PC

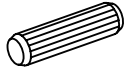
Z

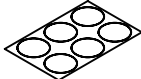
HARDWARE IDENTIFICATION

NO	DESCRIPTION	FIGURE	Q'TY	NO	DESCRIPTION	FIGURE	Q'TY
1	GLUE 15g		1 PC	7	BOLT Ø 6.2x45mm SR		4 PCS
2	CAM BOLT Ø 7x35.5mm SR		4 PCS	8	BOLT Ø 6.2x18mm SR		1 PC
3	CAM LOCK Ø 15x12mm SR		4 PCS	9	SCREW Ø 4.2x25.4mm RBW		10 PCS
4	ADJUSTMENT FEET Ø 35x17.2mm		4 PCS	10	WOODEN DOWEL Ø 8x30mm		4 PCS
5	COUPLER		5 PCS	11	STICKER Ø 20mm		1 PC
6	BOLT Ø 4.5x12mm SR		5 PCS				

Z4,Z5 not included in blister packaging.

NOTE:

Phillips head screw driver is required in the assembly process; however, manufacturer does not provide this item.

STEP 1

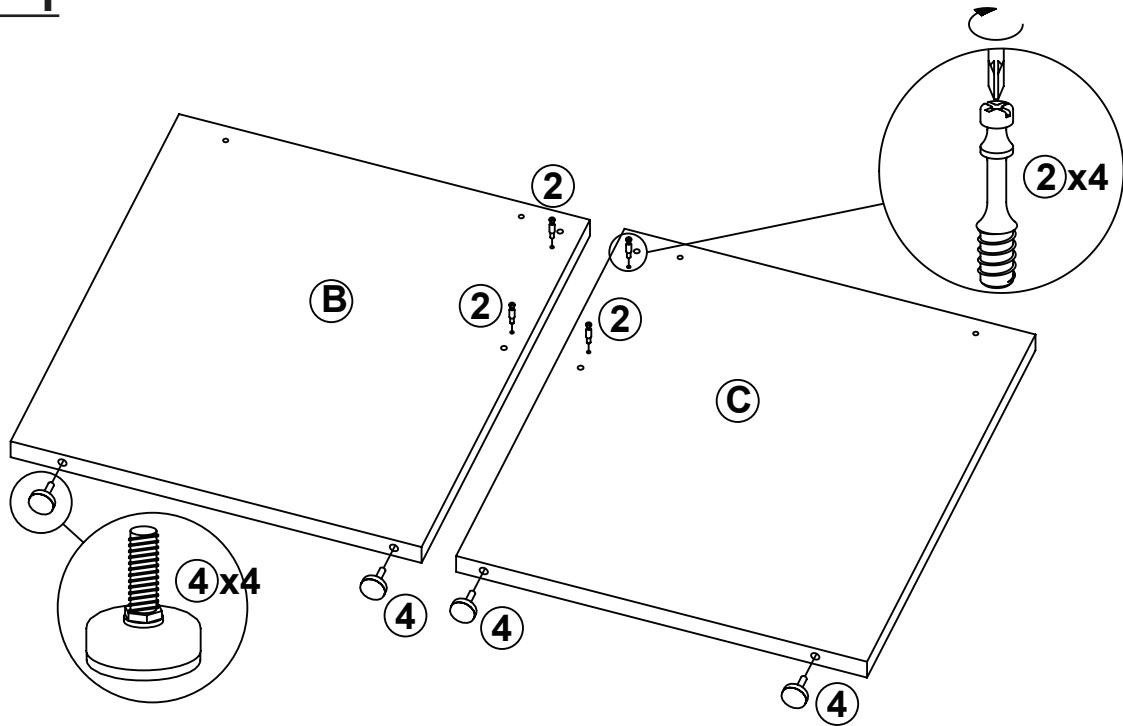

STEP 2

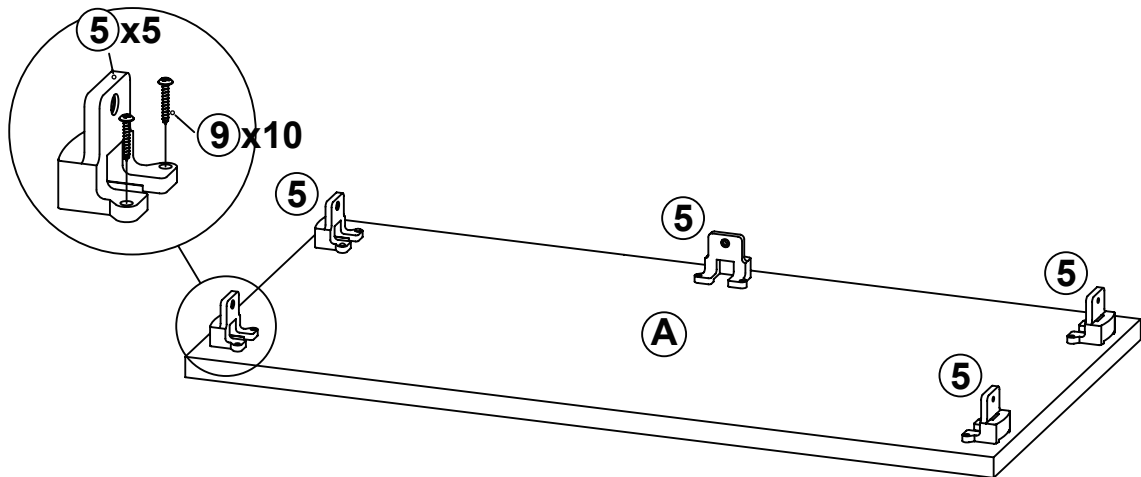

STEP 3

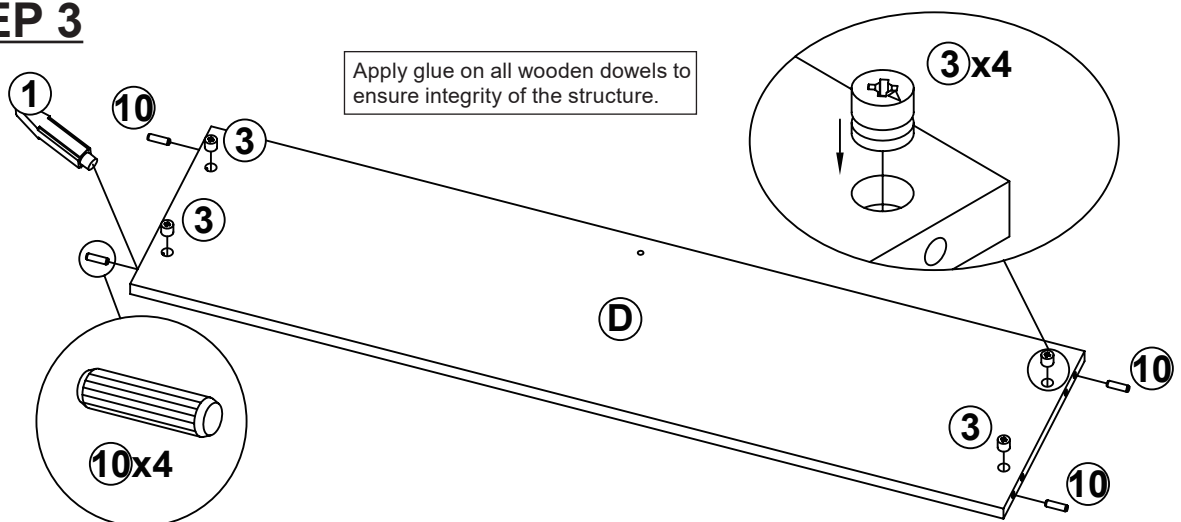

STEP 4

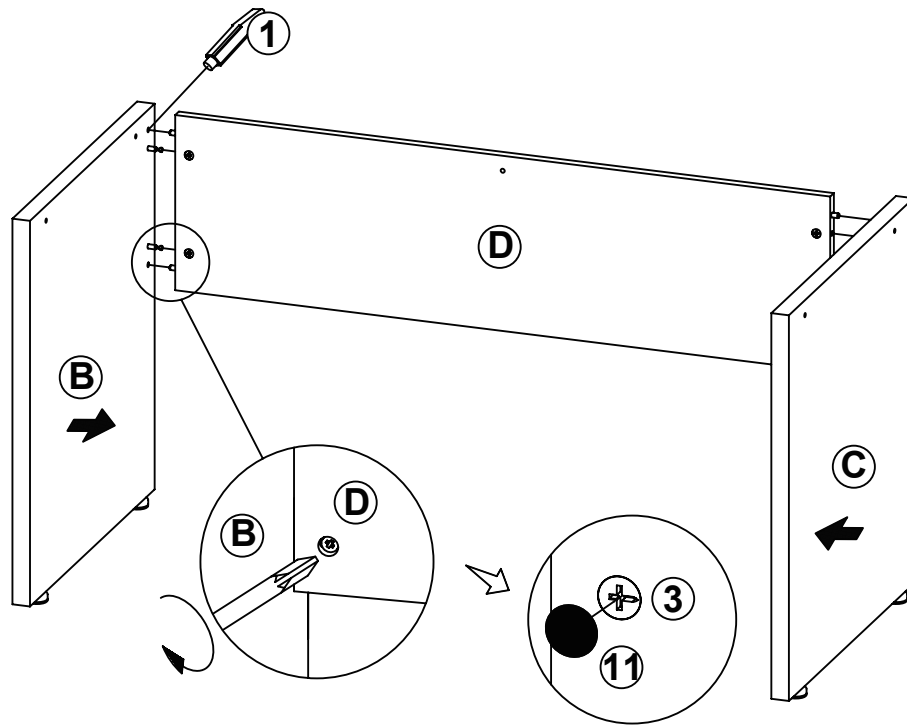

STEP 5

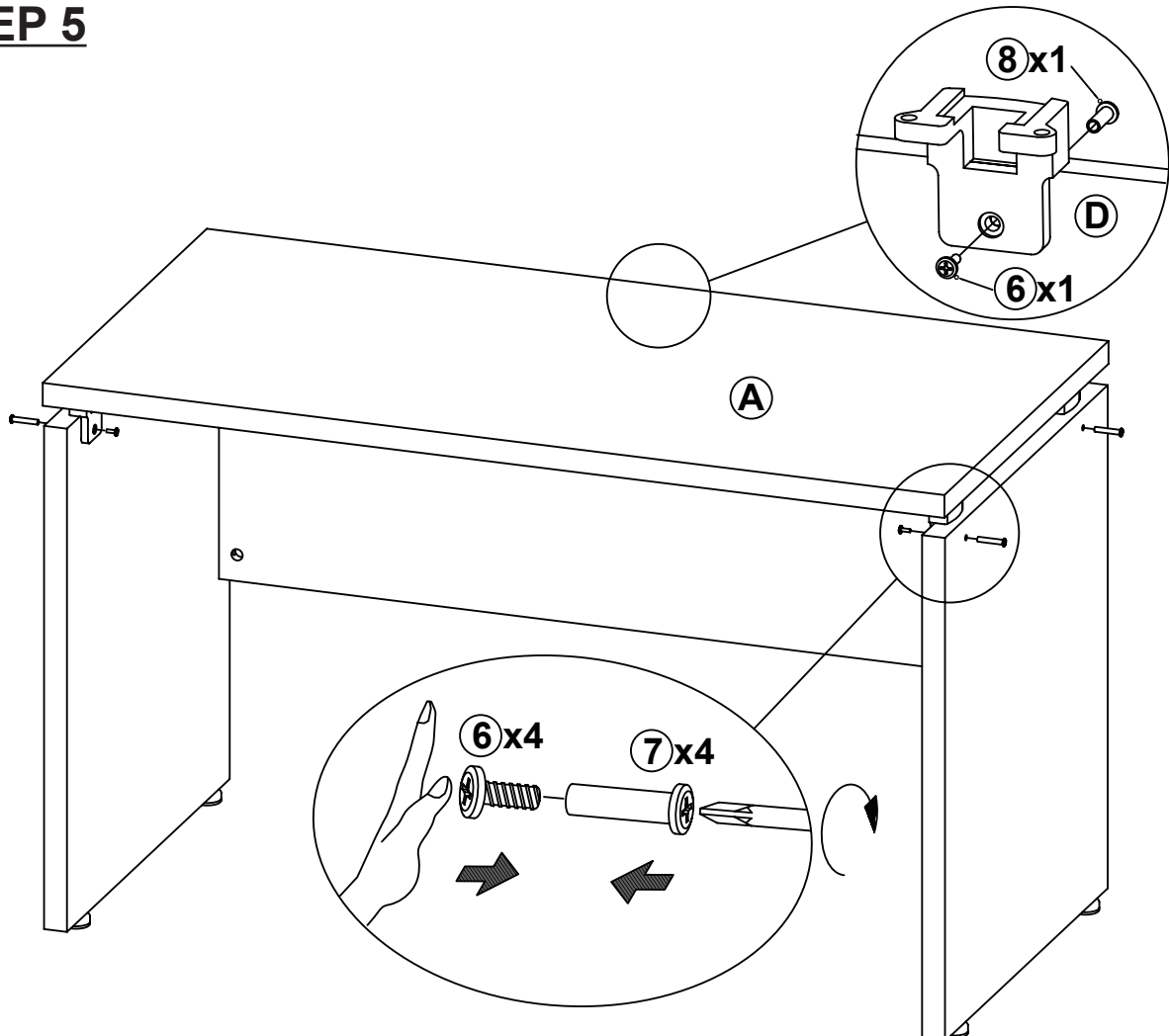

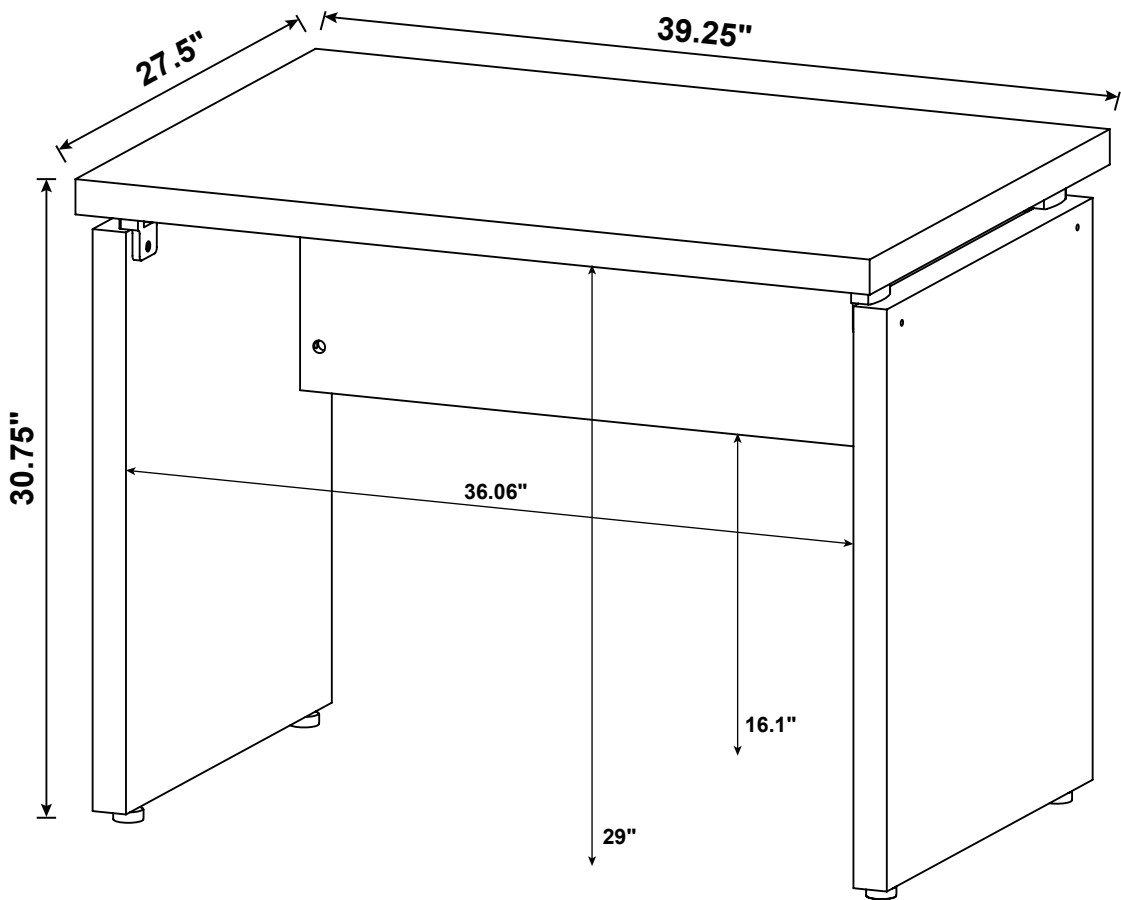

Note : Dimension tolerance $\pm 5\%$