

Installation Instructions for Economy Locking Insert

READ ALL INSTRUCTIONS PRIOR TO ASSEMBLY AND INSTALLATION

1. Completely remove the mailbox from its mount and/or bolster plate to expose the bottom of the box.
2. Open the mailbox door.
3. Locate and remove the black plastic pin attaching the flag bracket to the side of the mailbox (fig 1.1). Remove both the flag bracket and the flag from the mailbox.
4. With the locking door open, place the locking insert inside the mailbox being careful to line the holes up with the holes in the bottom of the mailbox.
5. Insert the supplied hex-head bolts through the bottom of the mailbox (fig 1.2). Use the supplied washer and nylock nut to hold the hex-head bolt in place, DO NOT TIGHTEN THE NUTS UNTIL ALL THE BOLTS ARE IN PLACE.
6. Once all the hex-head bolts are in place, tighten the nuts to secure the locking insert.
7. Re-attach the mailbox flag by first placing flag and mounting bracket onto the mailbox pushing the mounting bracket through the mounting holes. Next firmly re-insert the black plastic pin into the slot in the mounting bracket.
8. Re-attach the mailbox securely to its mount.

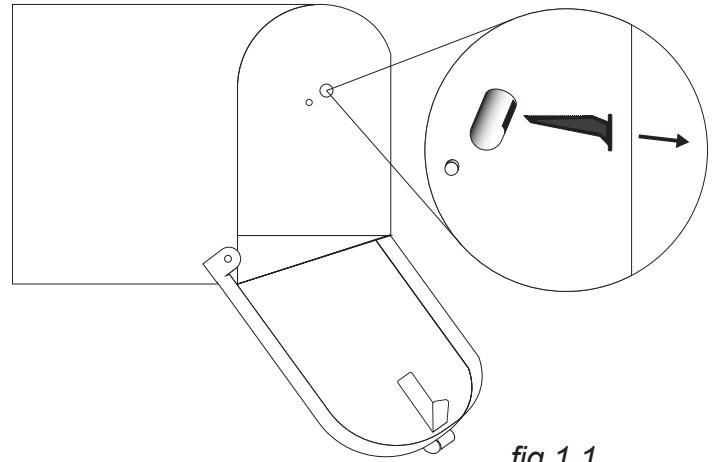

fig 1.1

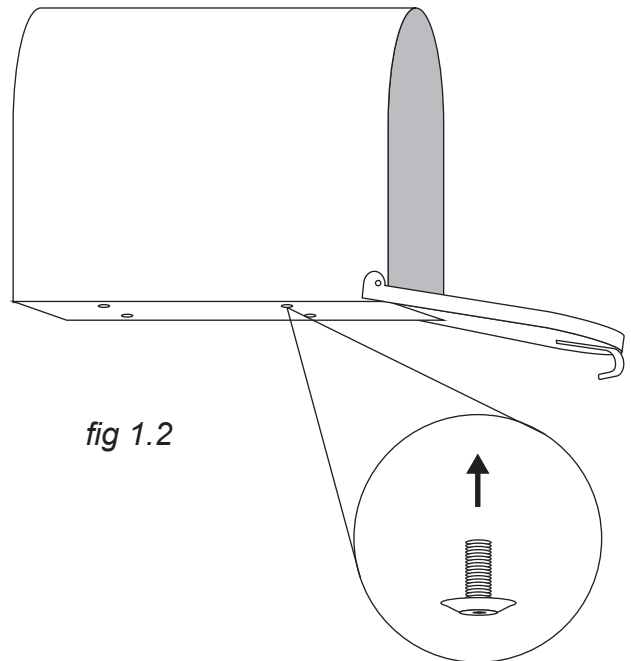

fig 1.2

**Outgoing mail can be placed on top of the locking insert. Incoming mail can be delivered securely inside the locking portion of the insert.*



QualArc
11300 Trade Center Dr., Ste. A
Rancho Cordova, CA 95742
916-273-1576
info@qualarc.com
www.qualarc.com