

ASSEMBLY INSTRUCTION

METAL FUTON

ASSEMBLY TIPS:

1. Remove hardware from box and sort by size.
2. Please check to see that all hardware and parts are present prior to start of assembly.
3. Please follow attached instructions in the same sequence as numbered to assure fast & easy assembly.







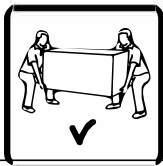

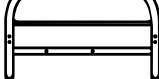

Warning!

1. Don't attempt to repair or modify parts that are broken or defective. Please contact the store immediately.
2. This product is for home use only and not intended for commercial establishment.











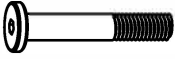



PARTS IDENTIFICATION

A	ARM (RIGHT)		1PC
B	ARM (LEFT)		1PC
C	SEAT FRAME		1PC
D	BACK FRAME		1PC
E	RAIL		2PC
F	RIGHT MECHANISM		1PC
G	LEFT MECHANISM		1PC
H	HOOK		1PC

Z

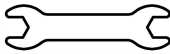
HARDWARE PACKAGE

NO	DESCRIPTION	FIGURE	Q' TY
1	BOLT (5/16" x3" L)		4PCS
2	BOLT (5/16" x1-3/4" L)		8PCS
3	BOLT (5/16" x1-1/4" L)		4PCS
4	WASHER		12PCS
5	LOCK WASHER (5/16")		12PCS
6	SPRING WASHER (1/4")		4PCS
7	BOLT (1/4" x1-1/4")		4PCS
8	WAVE WASHER		4PCS
9	NUT		12PCS
10	PAD		4PCS
11	WRENCH		1PCS
12	ALLEN KEY 5/16"		1PCS
13	ALLEN KEY 1/4"		1PCS

STEP1

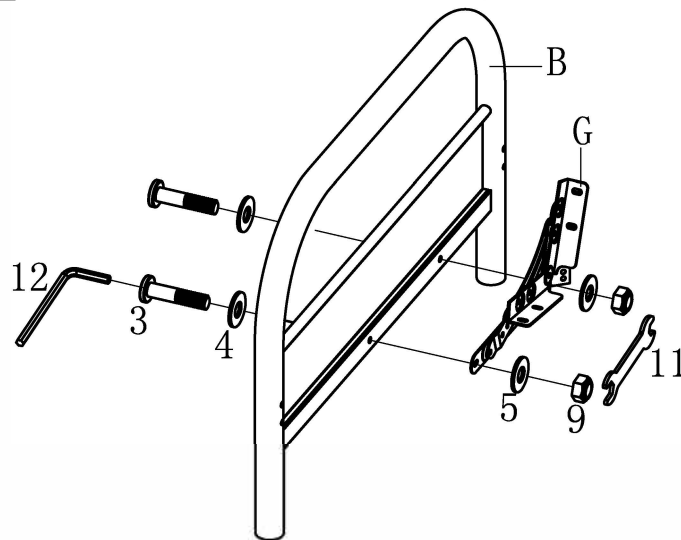

STEP2

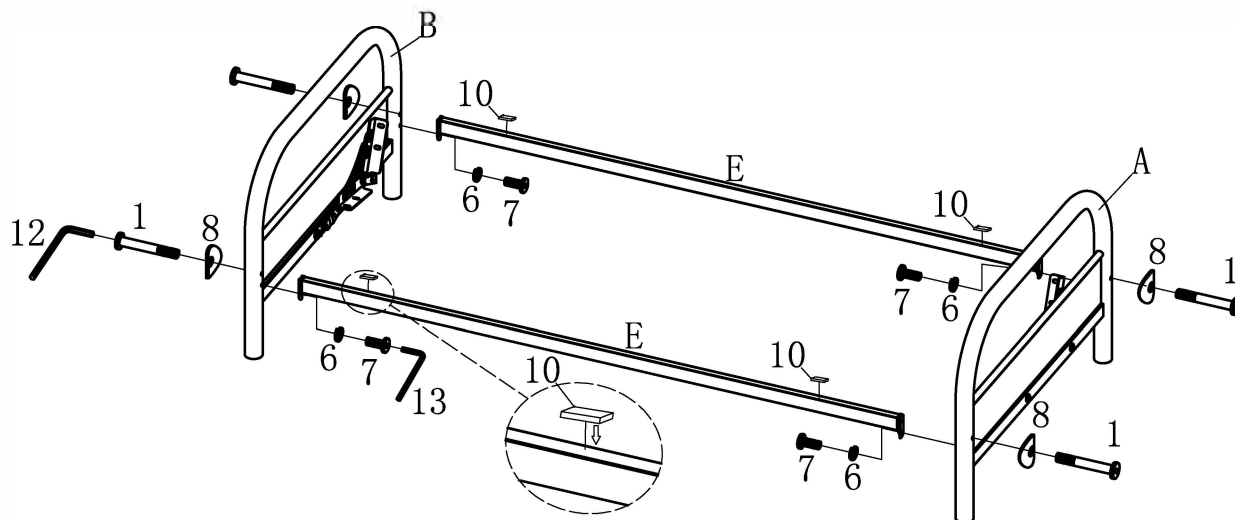

STEP3

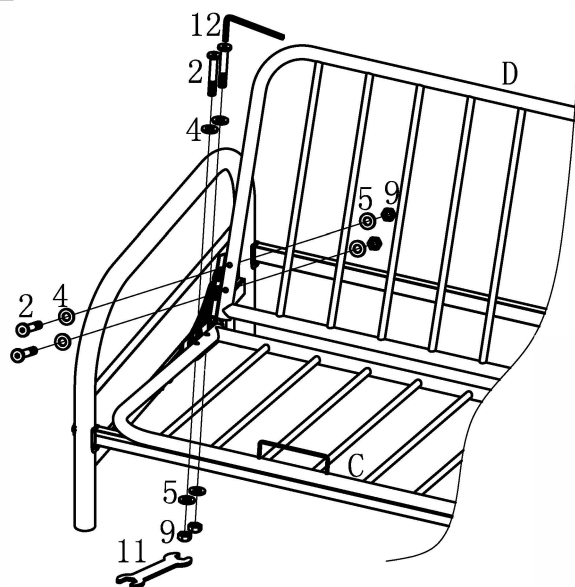

STEP4

