

# Assembly instructions

Warning -CHOKING HAZARD - Small Parts Not for children under 3 years. Adult assembly required.

## EU2507



Images for illustrative purposes only.

## ASSEMBLY INSTRUCTIONS

To assemble it, **2 people** are required.

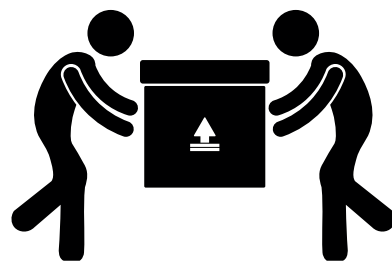

Tools required for assembly.  
Tools NOT provided.

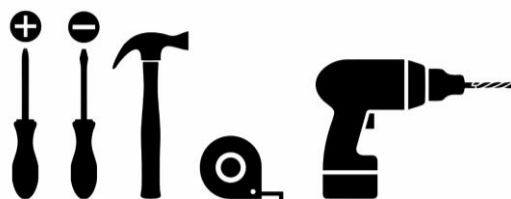

**CHOKING HAZARD** - This product contains small parts. Keep out of reach of children.



If in doubt, contact our customer service:

1 CS@K1intlgrp.com or Toll-free 1-877-250-2820



## ASSEMBLY INSTRUCTIONS

Follow the assembly steps carefully as indicated in the manual.



Before starting the assembly, identify and separate all the parts and accessories.



During assembly, keep parts and accessories organized to avoid accidents.



To protect your furniture, assemble it on a clean and flat surface.

**Tip:** You can use the product packaging to line the area where the assembly will be done.



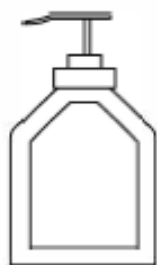
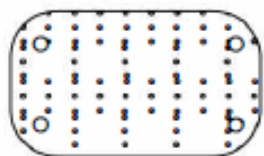

To Remove the printed number, apply a small amount of Glass Cleaner or Hand sanitizer and wipe with a paper towel.

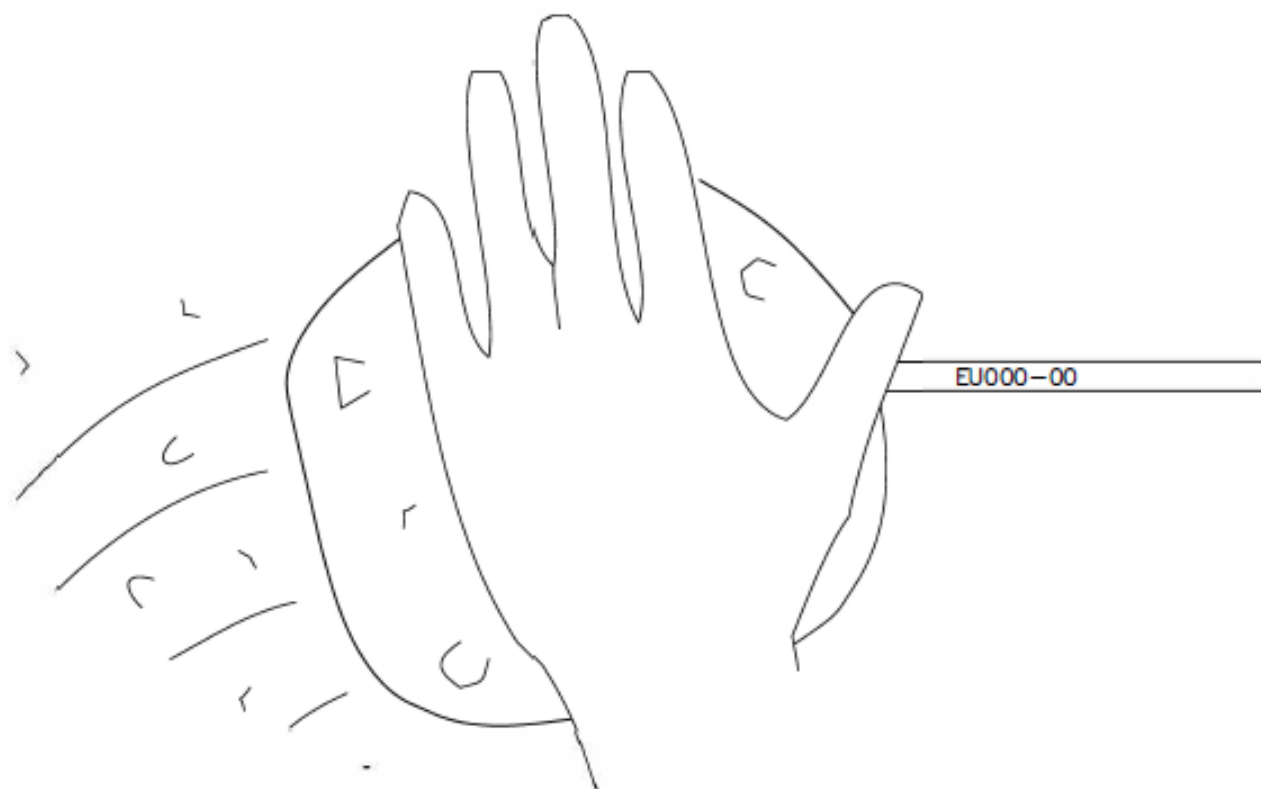

## PARTS IDENTIFICATION





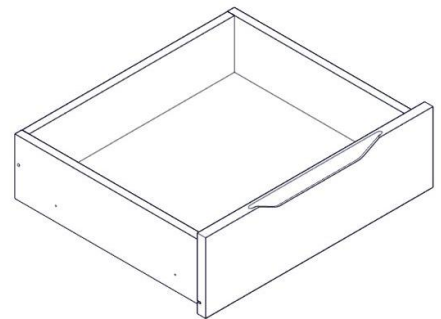
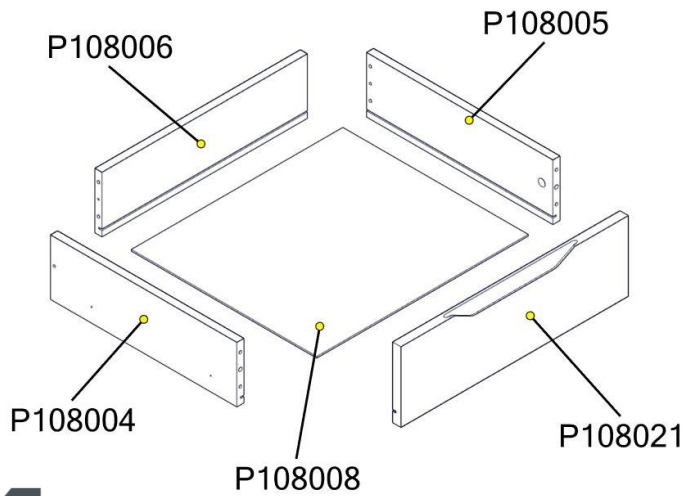
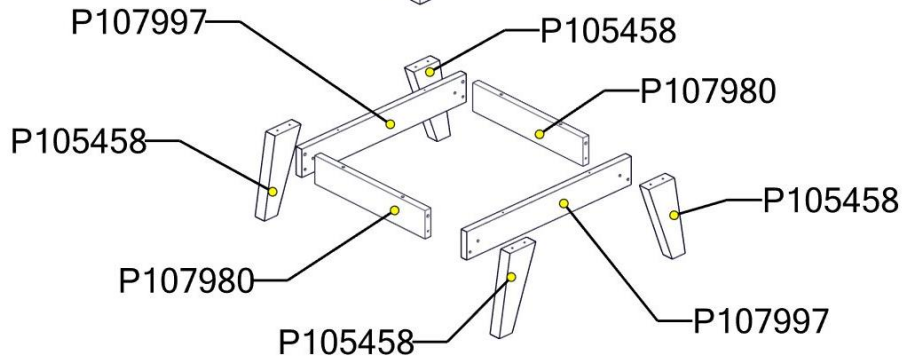
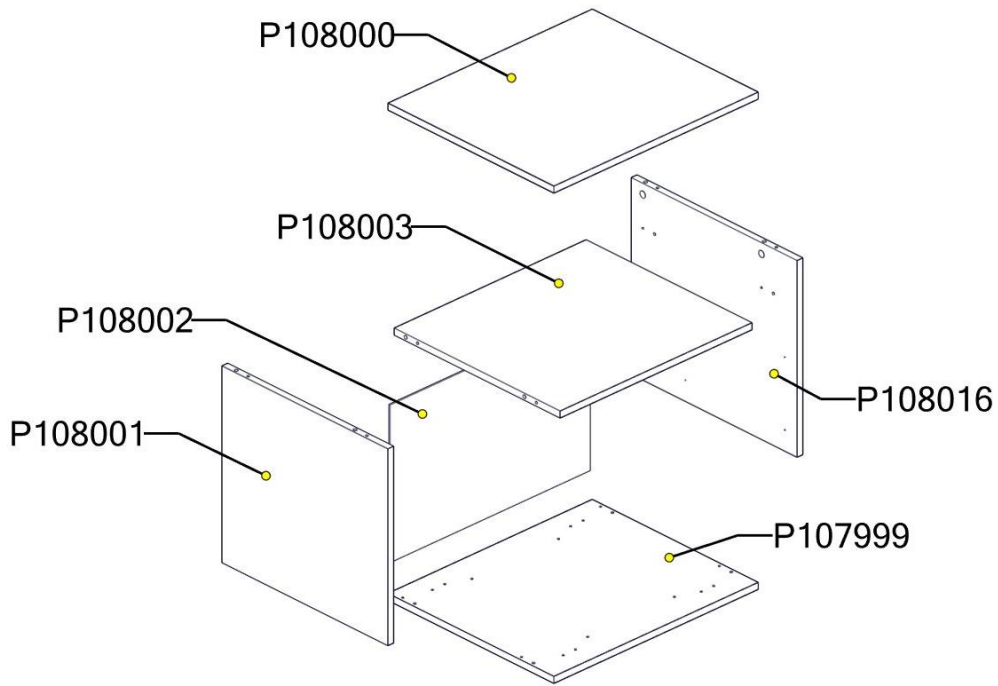



QTD.	CÓDIGO / CODE	DESCRIÇÃO (Internal production data)	DESCRIPTION	C x L x E	L x W x T
4	P105458	PE	FOOT OF FURNITURE	181 x 66 x 25 mm	7.13 x 2.60 x 0.98 in
2	P107980	RODAPE	BASEBOARD	297 x 60 x 15 mm	11.69 x 2.36 x 0.59 in
2	P107997	RODAPE	BASEBOARD	425 x 60 x 15 mm	16.73 x 2.36 x 0.59 in
1	P107999	BASE	BASE	528 x 447 x 15 mm	20.79 x 17.60 x 0.59 in
1	P108000	TAMPO	TOP	528 x 447 x 15 mm	20.79 x 17.60 x 0.59 in
1	P108001	LATERAL ESQUERDA	LEFT SIDE	418 x 447 x 15 mm	16.46 x 17.60 x 0.59 in
1	P108002	COSTA	COAST	517 x 335 x 3 mm	20.35 x 13.19 x 0.12 in
1	P108003	PRATELEIRA	SHELF	496 x 447 x 15 mm	19.53 x 17.60 x 0.59 in
2	P108004	LATERAL DE GAVETA ESQUERDA	LEFT DRAWER SIDE	400 x 120 x 15 mm	15.75 x 4.72 x 0.59 in
2	P108005	LATERAL DE GAVETA DIREITA	DRAWER RIGTH SIDE	400 x 120 x 15 mm	15.75 x 4.72 x 0.59 in
2	P108006	CABECEIRA DE GAVETA	DRAWER HEAD	441 x 120 x 15 mm	17.36 x 4.72 x 0.59 in
2	P108008	FUNDO DE GAVETA	DRAWER BOTTOM	454 x 398 x 3 mm	17.87 x 15.67 x 0.12 in
1	P108016	LATERAL DIREITA	RIGHT SIDE	418 x 447 x 15 mm	16.46 x 17.60 x 0.59 in
2	P108021	FRENTE DE GAVETA	DRAWER FRONT	488 x 150 x 18 mm	19.21 x 5.91 x 0.71 in

# PARTS IDENTIFICATION

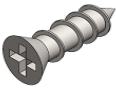

## IDENTIFICATION OF ACCESSORIES

**NOTE:** Separating the accessories before starting assembly will make it easier. In case of doubt in the identification, place the accessory on the ruler.

	QTD.	CÓDIGO / CODE	DESCRIÇÃO (Internal production data)	DESCRIPTION
	20	000107	PREGO 10 X 10 LISO	NAIL 10 X 10
	5	000108	PREGO 12 X 12 ARDOX	NAIL 12 X 12
	5	000414	P.PANELA 4,0 X 35 CAB. PHILLIPS ZB/BC	SCREW 4,0 X 35
	2	001178	P.FLANGE 3,5 X 16 CAB. PHILLIPS BC	SCREW 3,5 X 16
	24	004214	P.CHATO 3,5 X 14 CAB. PHILLIPS REBAIXADA ZB	SCREW 3,5 X 14MM
	4	005256	P.CHATO 4,0 X 20 CAB. PHILLIPS ZB/BC	FLAT SCREW 4,0 X 20 BC
	13	030945	PARAFUSO DE ACO P/ MINIFIX	MINIFIX DOWEL
	2	051980	P.CHATO 4,5 X 50 BC	FLAT HEAD SCREW 4,5 X 50MM
	25	075515	P.ESTRUTURAL 5 X 40 CAB. 13 ALLEN 3 C/PONTA ZB/BC	SCREW 5 X 40

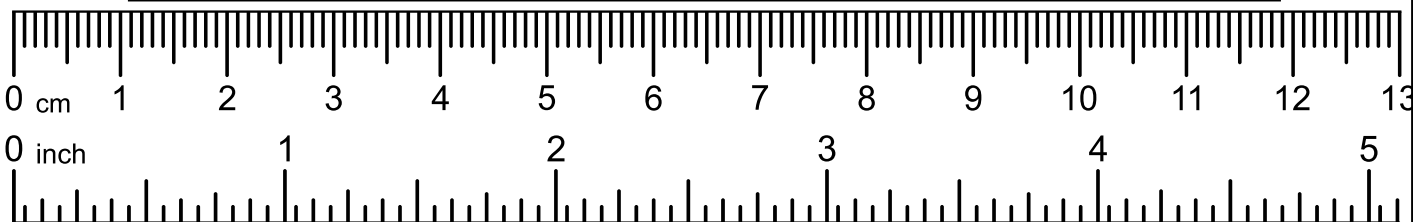

## IDENTIFICATION OF ACCESSORIES

**NOTE:** Separating the accessories before starting assembly will make it easier. In case of doubt in the identification, place the accessory on the ruler.

	QTD.	CÓDIGO / CODE	DESCRIÇÃO (Internal production data)	DESCRIPTION
	1	000041	COLA BRANCA EM BISNAGA (10GR)	GLUE
	36	001802	CAVILHAS DE MADEIRA 6X30 PINUS	DOWEL 6X30MM
	5	001901	SAPATA DESLIZADORA PRETA 15 X 6	SHOE 15 X 6
	4	018458	SUPORE TRIANGULAR PRETO	TRIANGLE SUPPORT
	13	030950	TAMBOR P/ MINIFIX 15MM ZAMAQ	MINIFIX CAM 15MM
	2	032069	BUCHA PARA GESSO FLY 2	FIXING BUSHING FOR PLASTER
	2	055606	SUP. P/ FIXACAO DE PAREDE (EUA)	FIXATION SUPPORT
	1	055607	ABRACADEIRA NYLON 300 MM	NYLON CLAMP 300 MM
	1	058788	CHAVE ALLEN Z 3X40MM ZB/BC	ALLEN WRENCH
	2 (KIT)	CRTM350X35	CORREDICA TELESCOPICO LIGHT (H35) 350MM	SLIDING DRAWER SYSTEM
	8	19MM	TAPA FURO 19MM	SCREW CAP COVER 19MM

### INSTALLING CAM

Identify arrow on head of cam. Arrow MUST point toward hole in edge of panel. Push cam all the way down into hole.

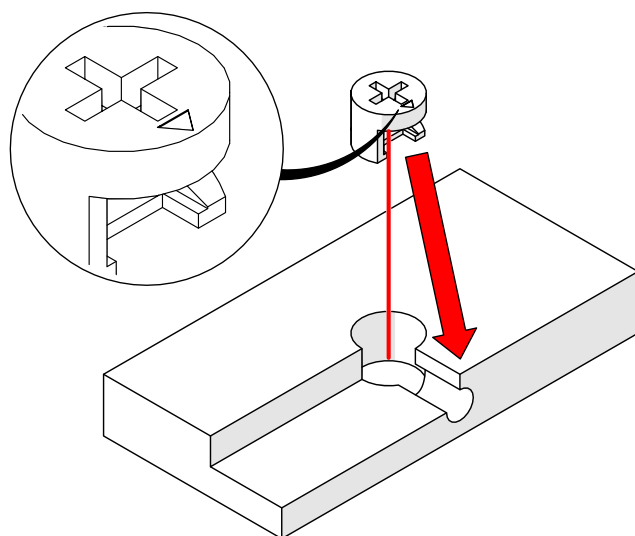

### CAM AND DOWEL ALIGNMENT

Ensure the arrow on the cam points toward hole and insert cam dowel into hole. Make sure pieces join together.

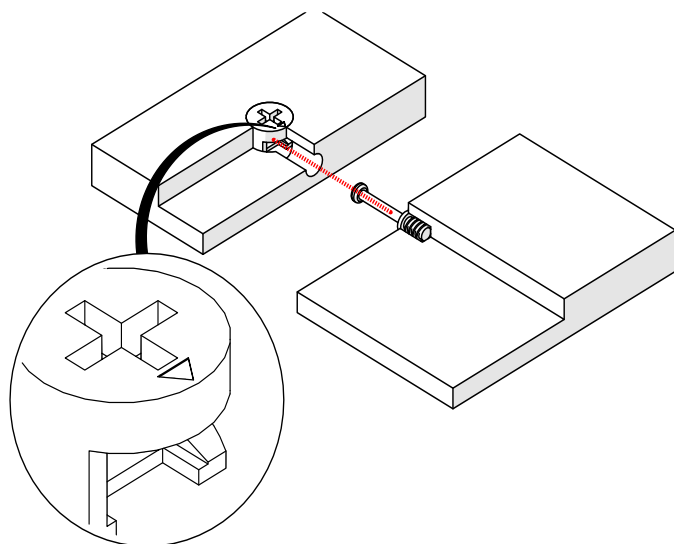

### TIGHTENING CAM

Use screwdriver to turn cam. Turn cam (clockwise) until fully tightened. Slightly more than half a turn.

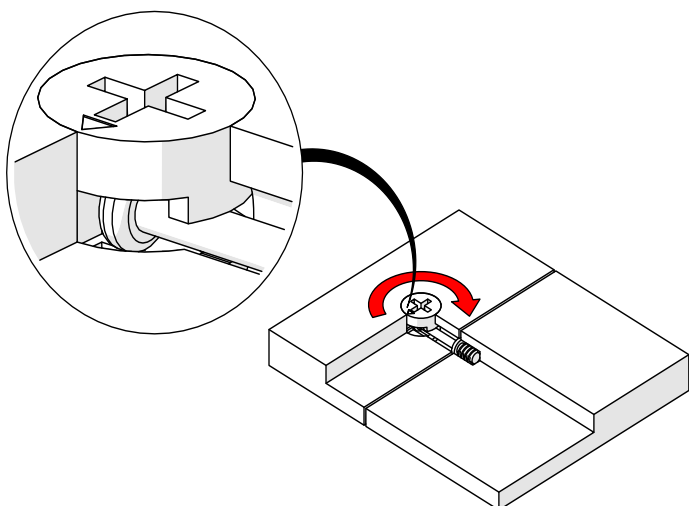

## View upon unboxing the drawer glides

#1 NOTICE – Please view this video (VIA QR CODE) prior to installing the Telescopic rail, as this will allow you to be better informed on the process. Ensuring proper installation.

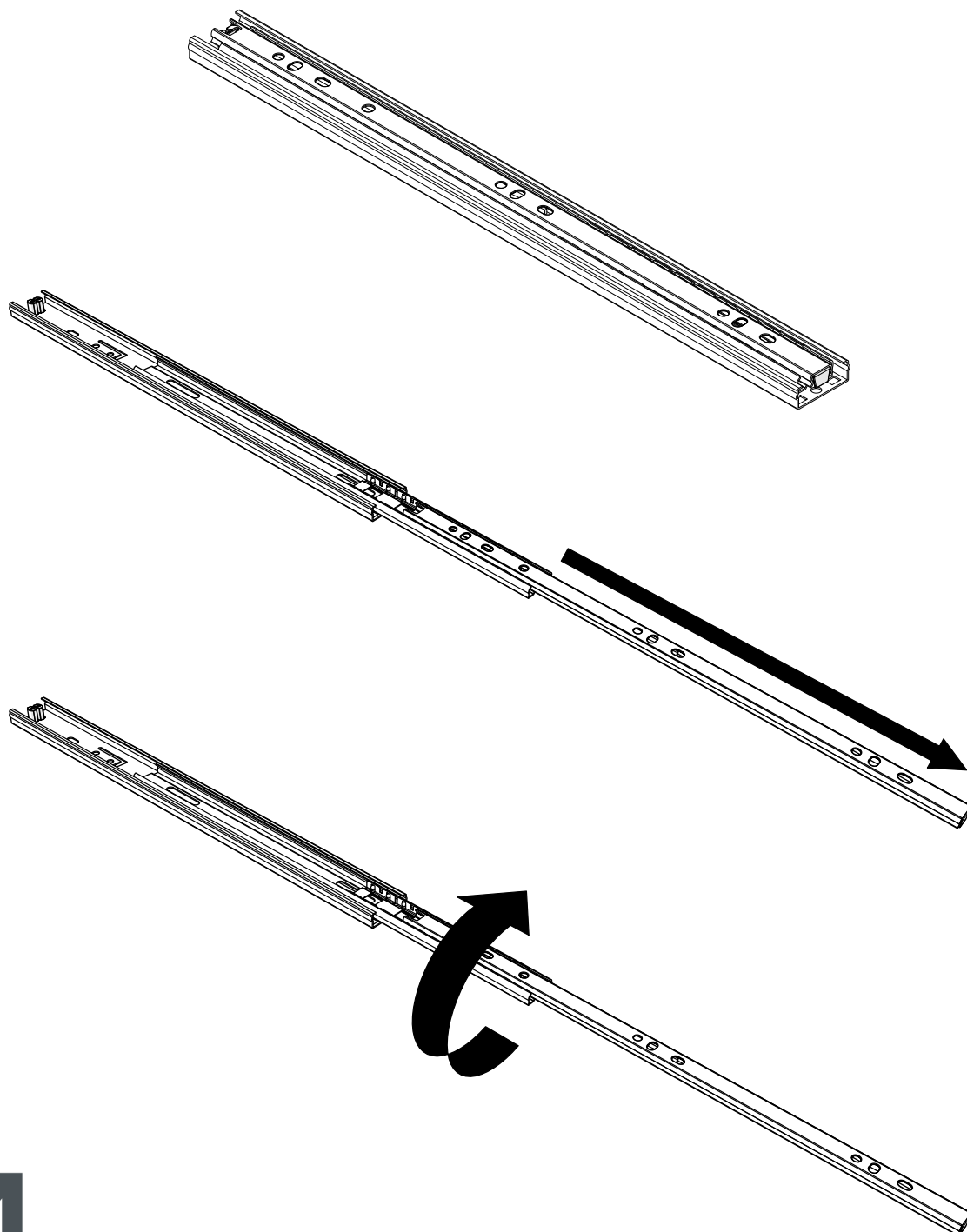

#2 NOTICE - Please note this process might leave a small amount of harmless oil on your fingers, please ensure you have a paper towel or rag to wipe off if needed to not damage clothes.

To separate the parts of the slide, pull the hook on the back of the slide (illustration below) counterclockwise, separating the two parts, to facilitate attachment to the furniture.

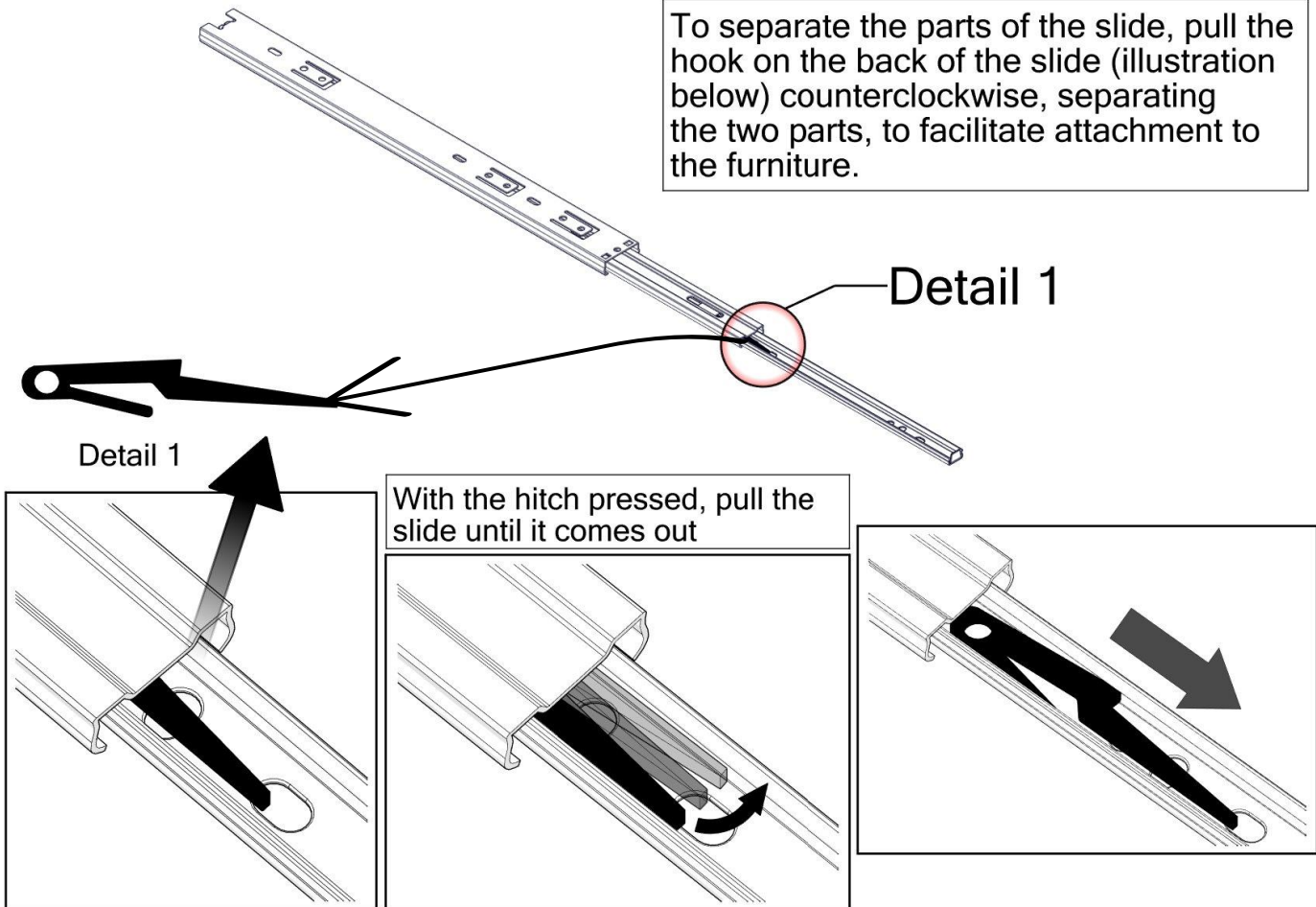

## DRAWER SLIDE

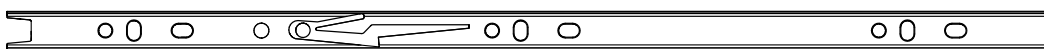

## SIDE SLIDE



# STEP 1 - A

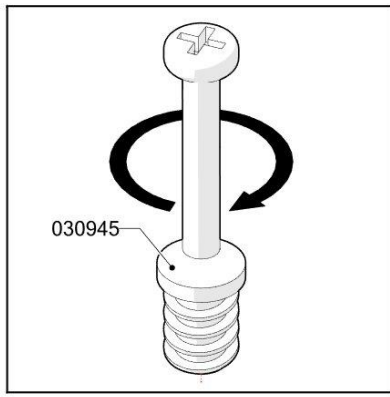

Cód.	Qtde.
001802	4
030945	2

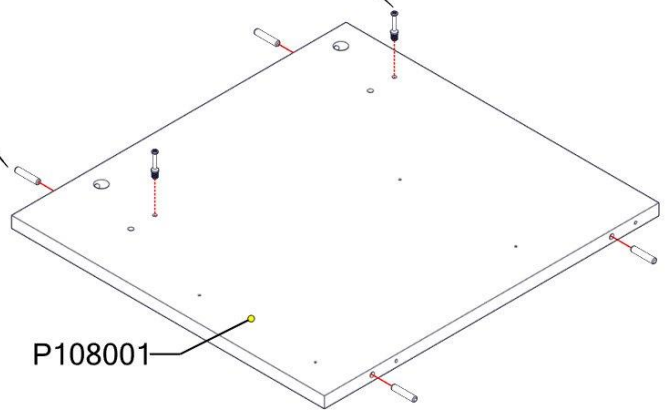
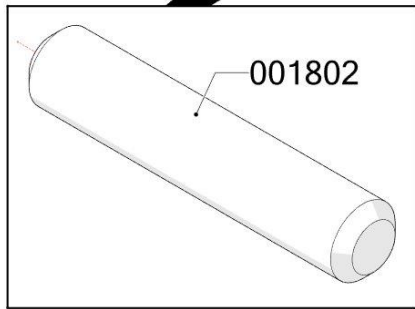

# STEP 1 - B

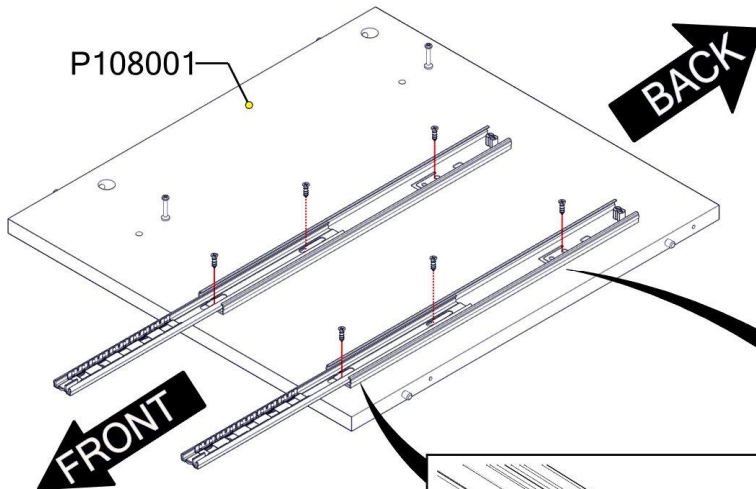

Cód.	Qtde.
CRTM350X35	2
004214	6

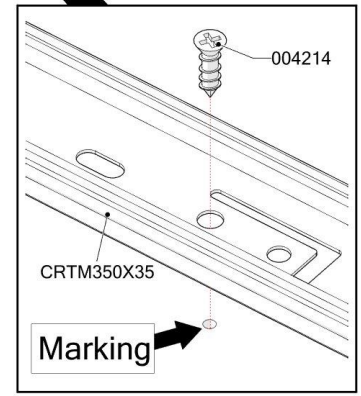
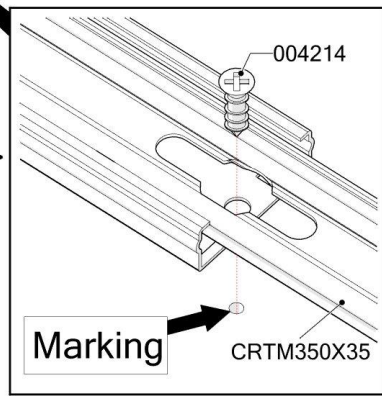
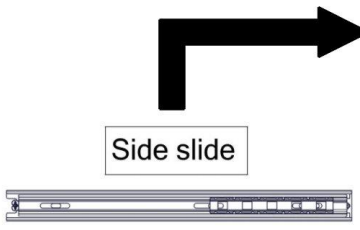

## STEP 2 - A

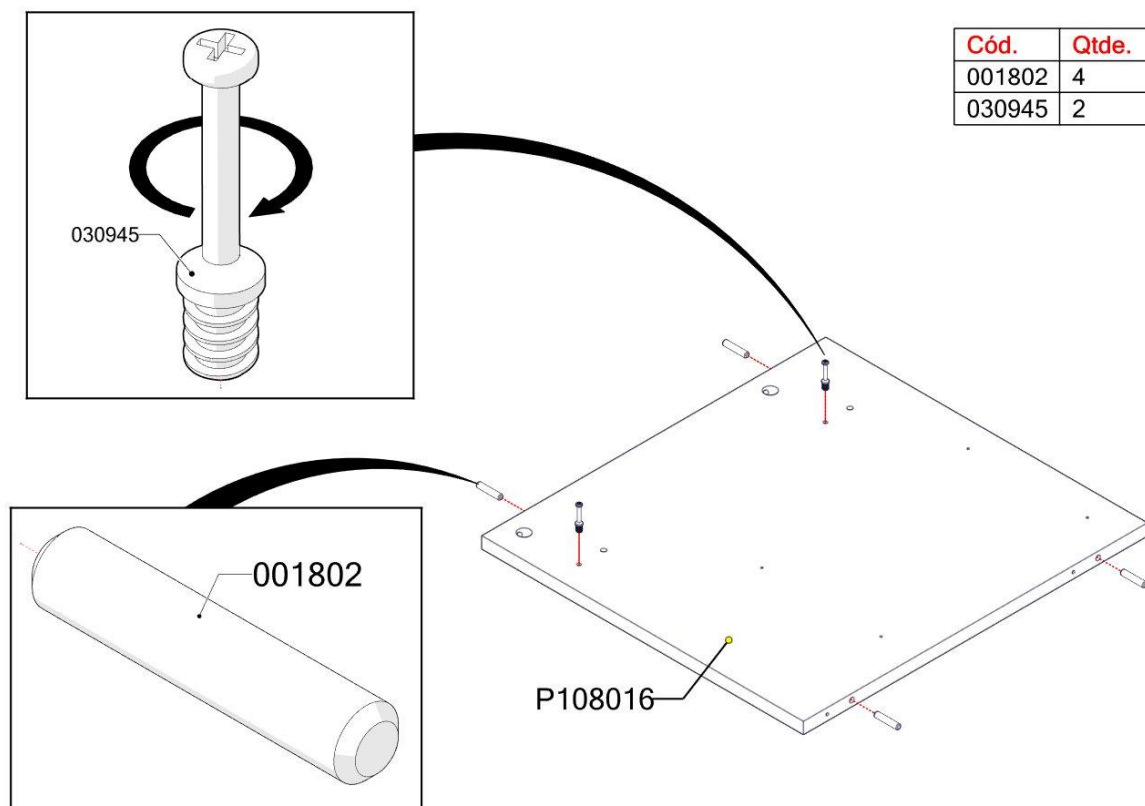

## STEP 2 - B

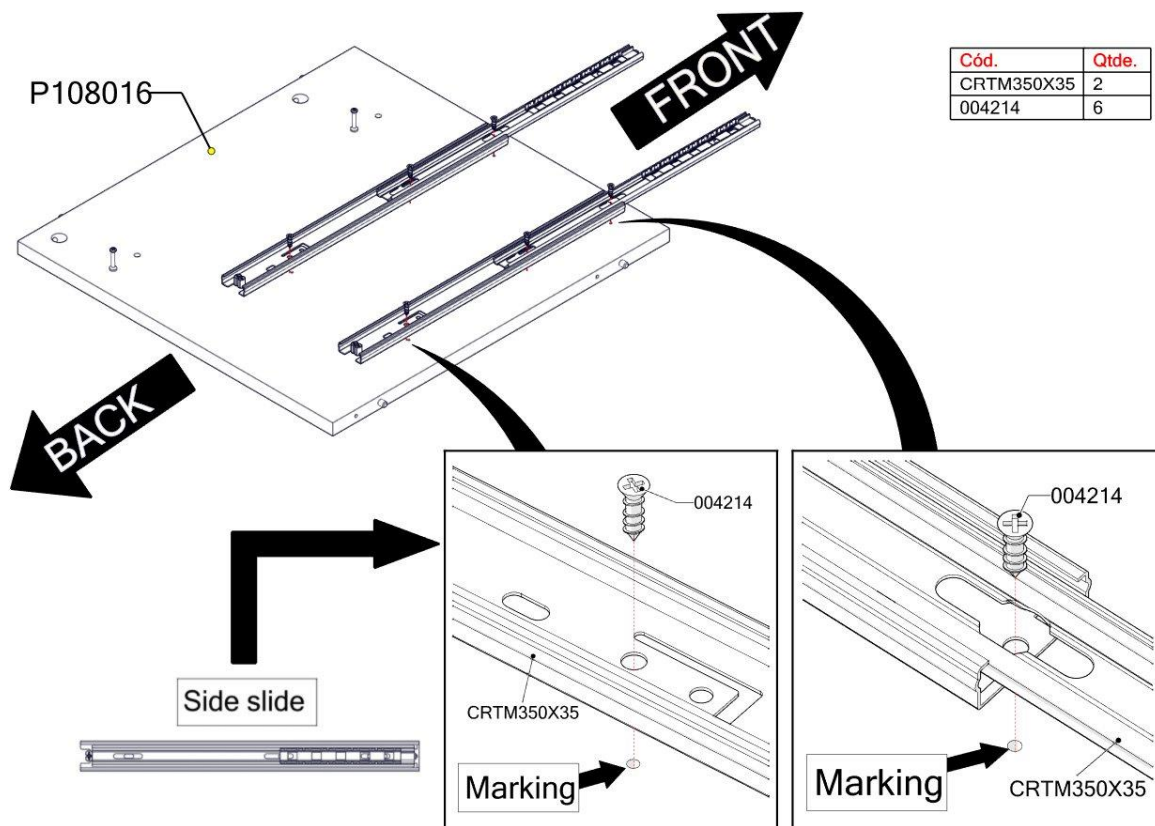

### STEP 3

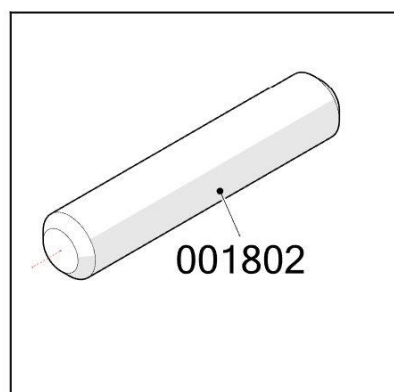

Cód.	Qtde.
001802	8

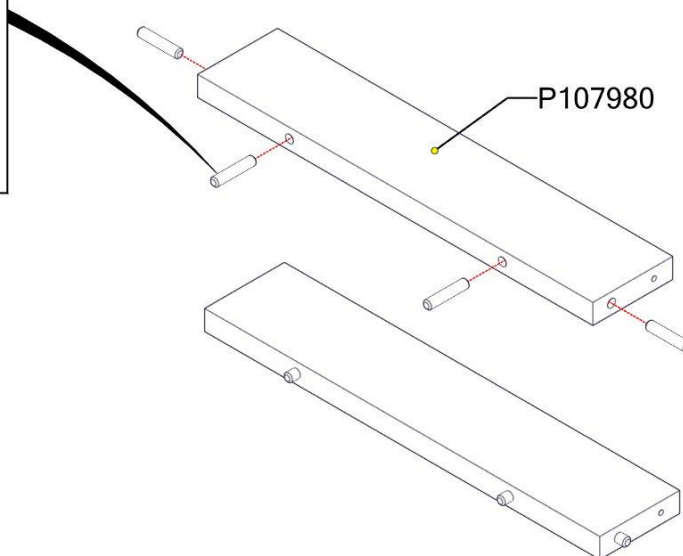

### STEP 4

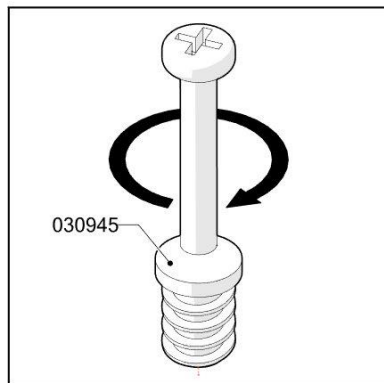

Cód.	Qtde.
030945	4

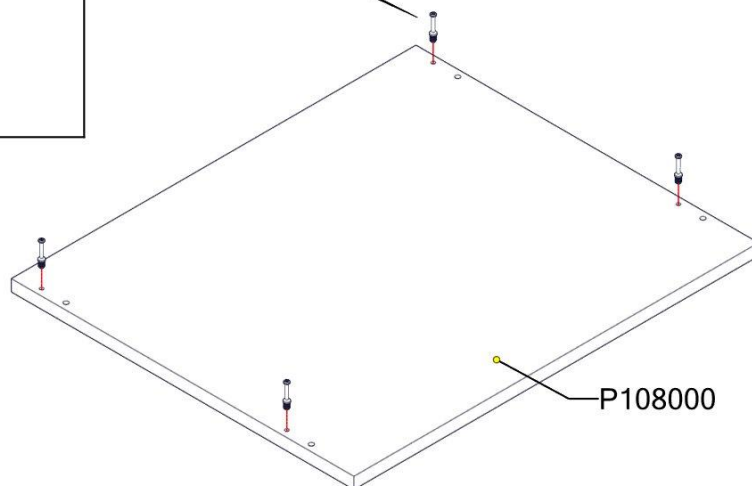

## STEP 5

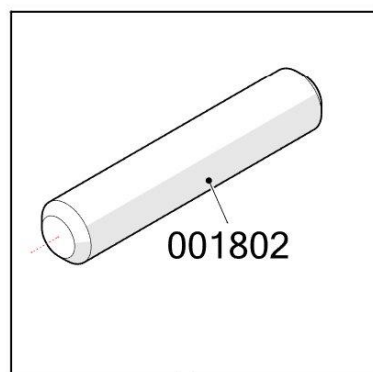

Cód.	Qtde.
001802	4

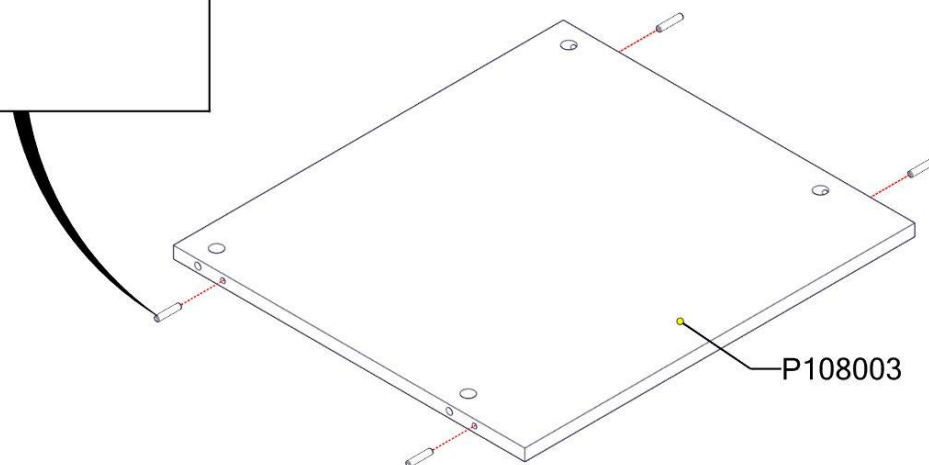

## STEP 6

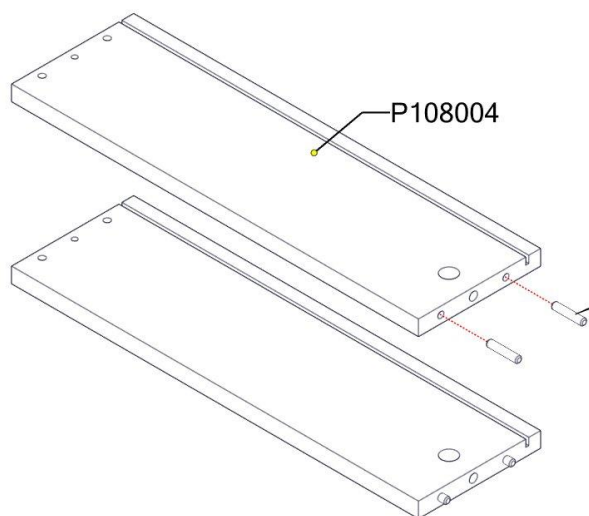

Cód.	Qtde.
000041	1
001802	4

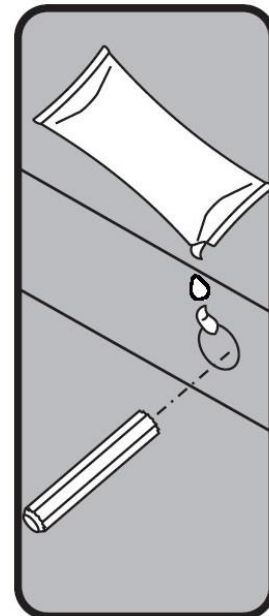
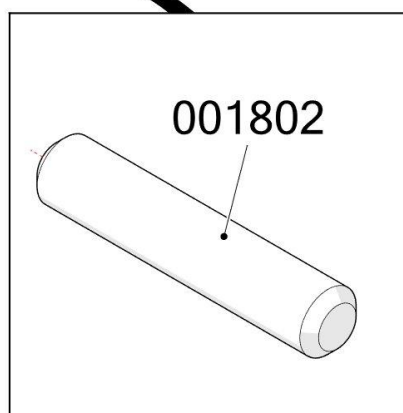

## STEP 7

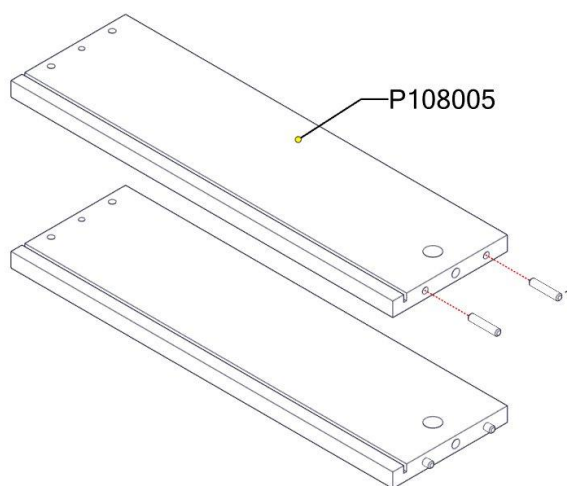

Cód.	Qtde.
000041	1
001802	4

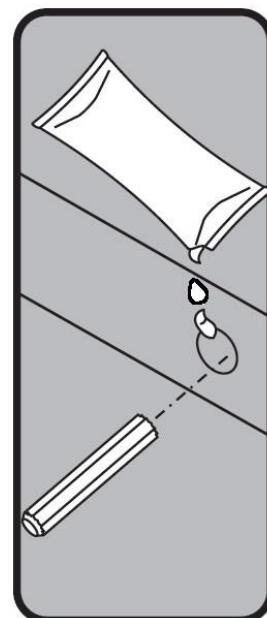
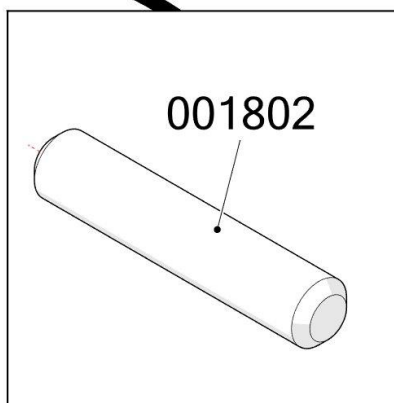

## STEP 8

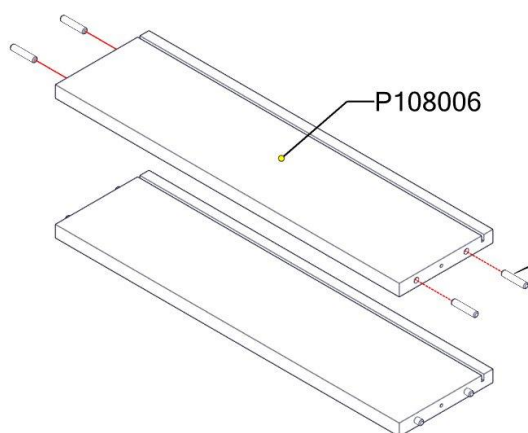

Cód.	Qtde.
000041	1
001802	8

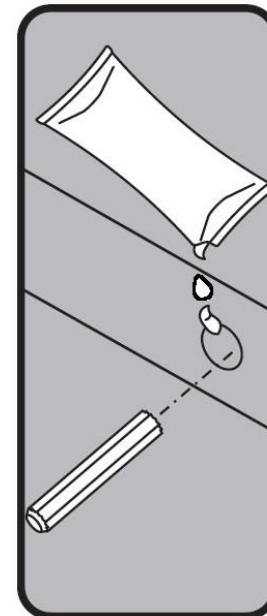
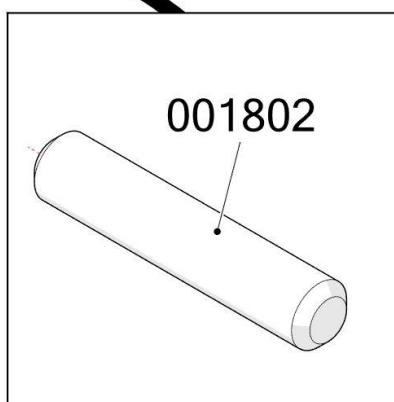

## STEP 9

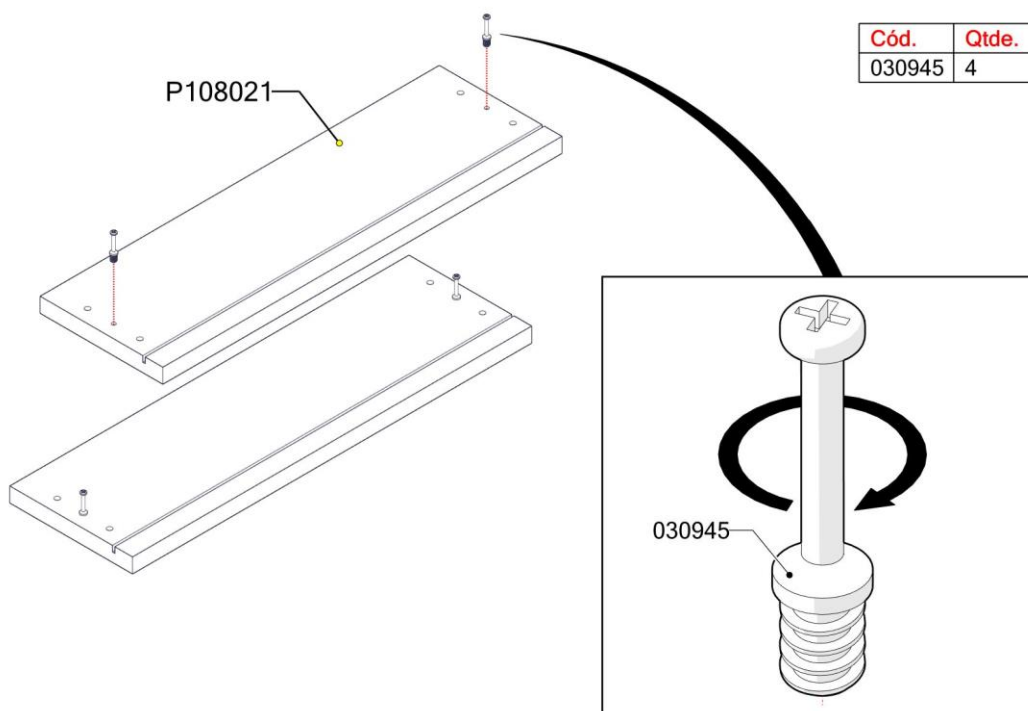

## STEP 10

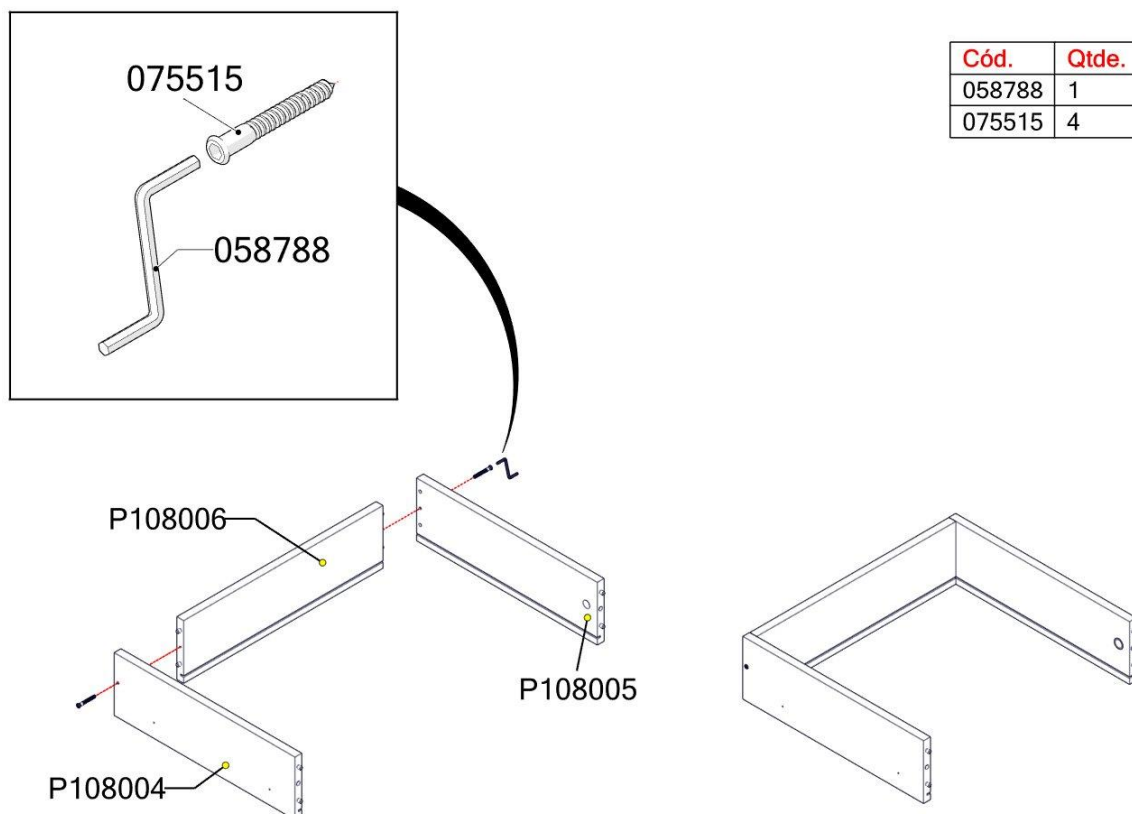

## STEP 11

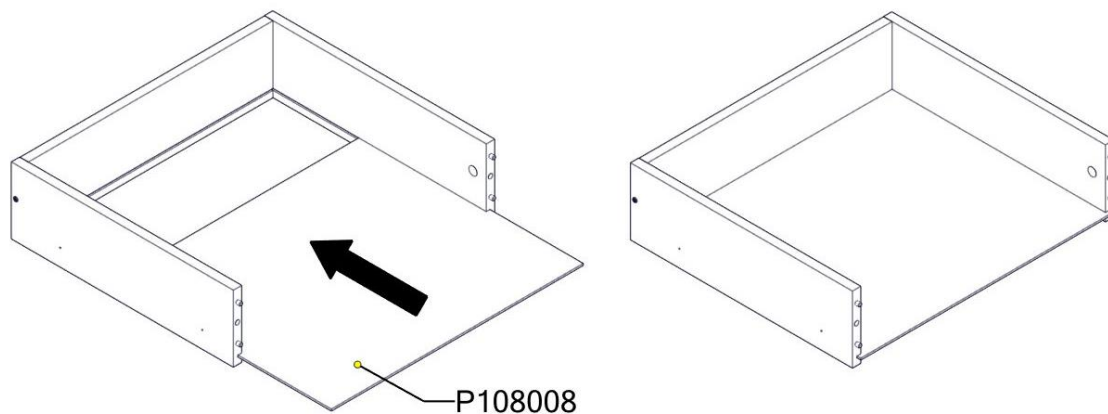

## STEP 12

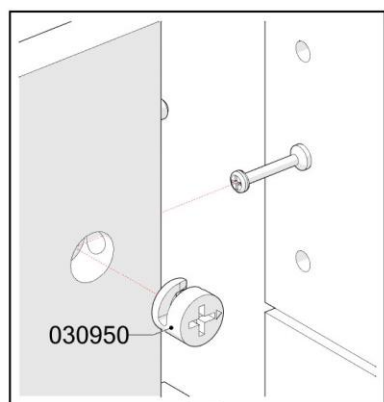

Cód.	Qtde.
030950	4

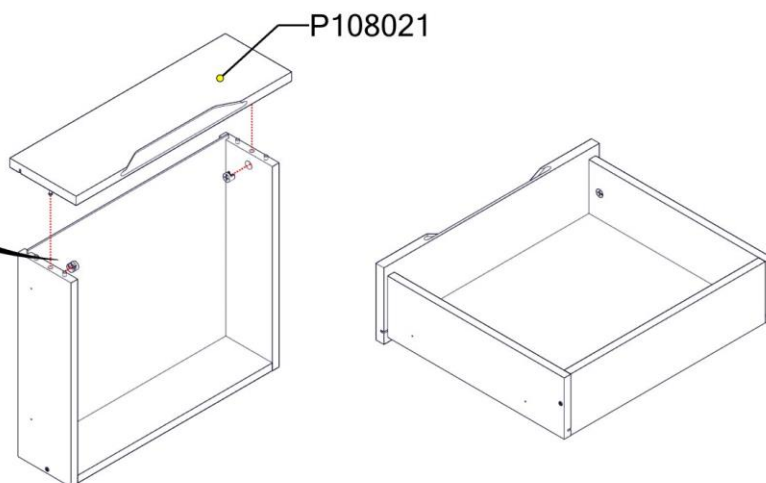

# Drawer slide

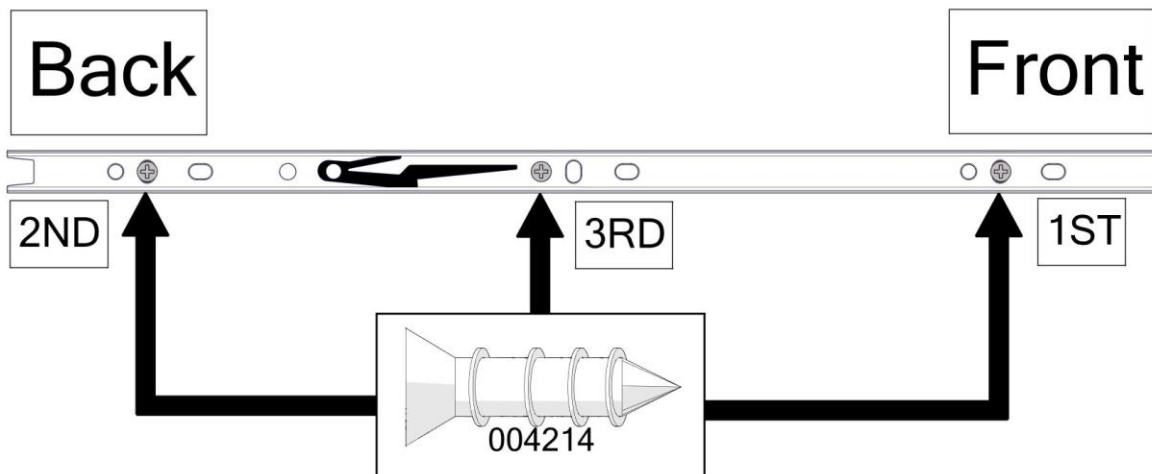

Cód.	Qtde.
004214	12
CRTM350X35	4

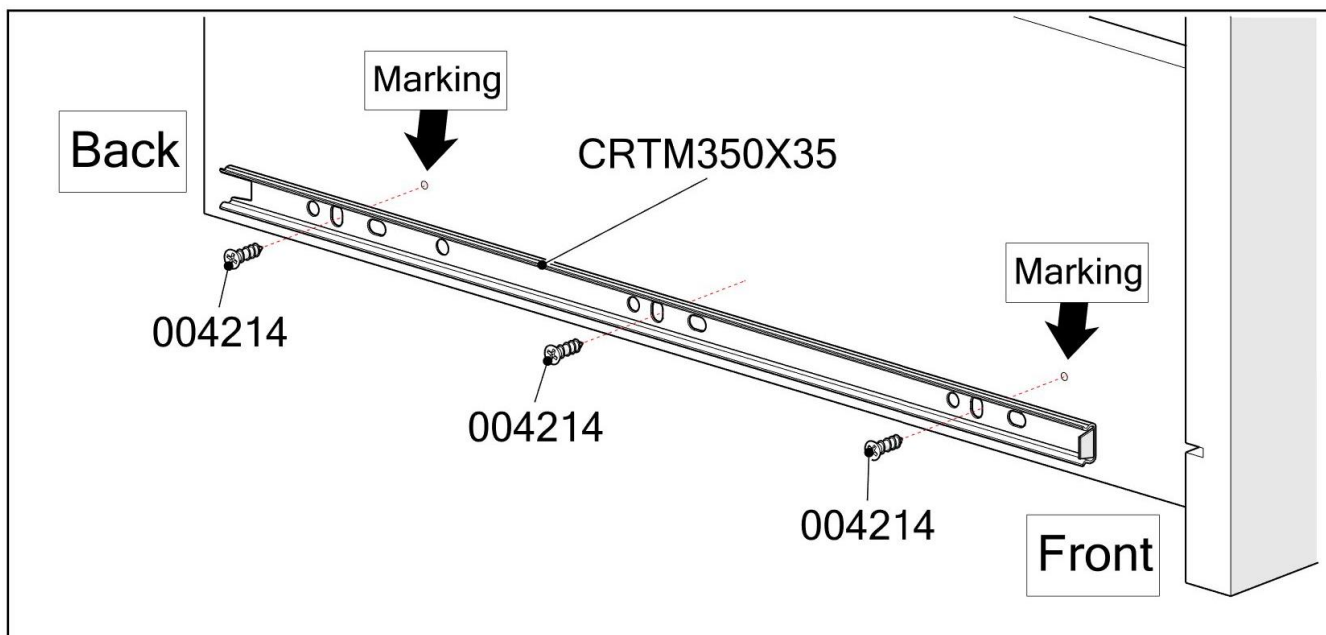
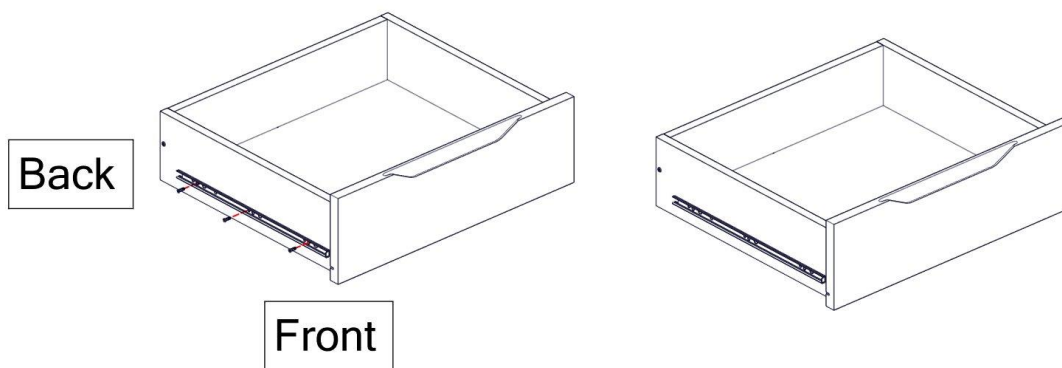

## STEP 14

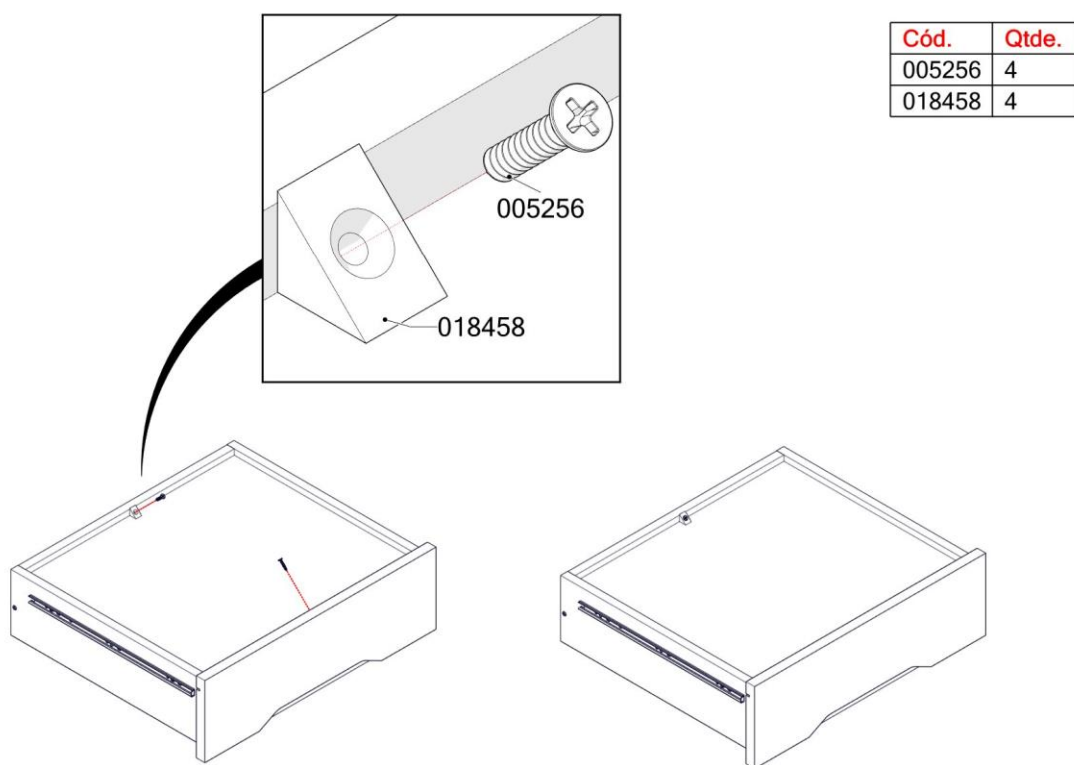

## STEP 15

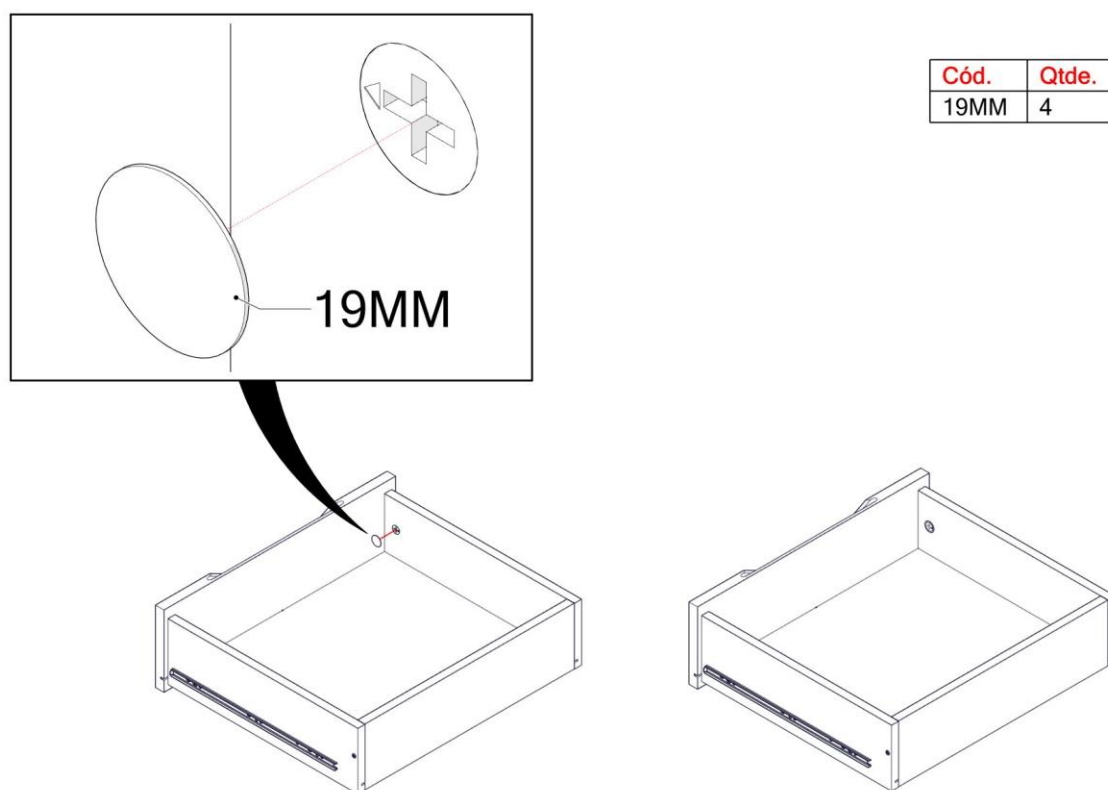

# STEP 16

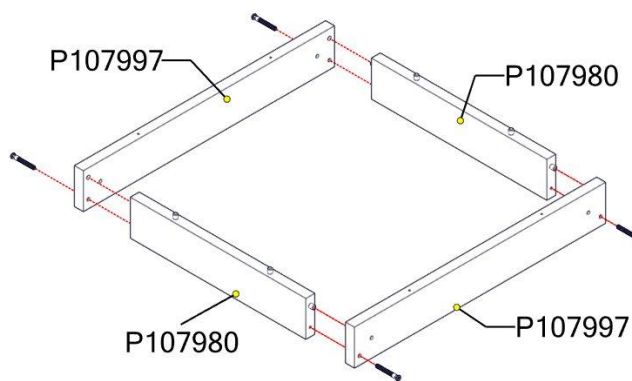

Cód.	Qtde.
058788	1
075515	4

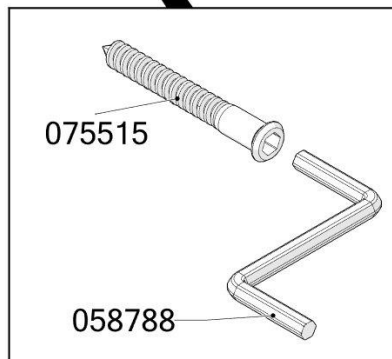

# STEP 17

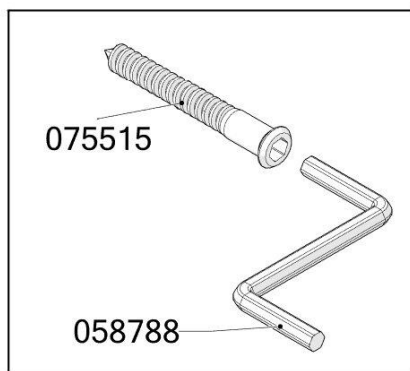

Cód.	Qtde.
058788	1
075515	8

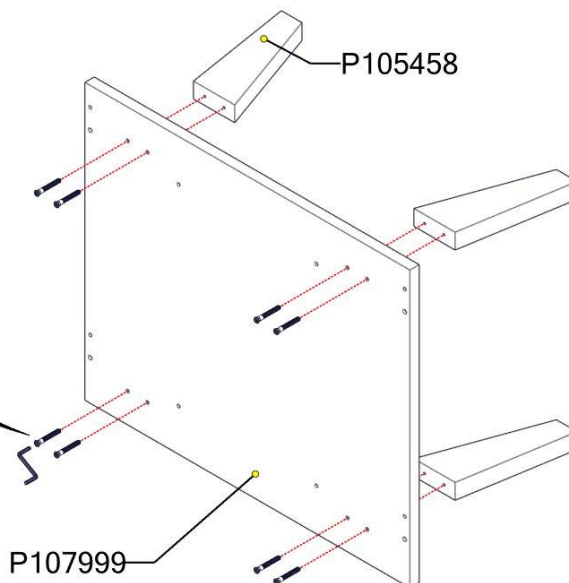

## STEP 18

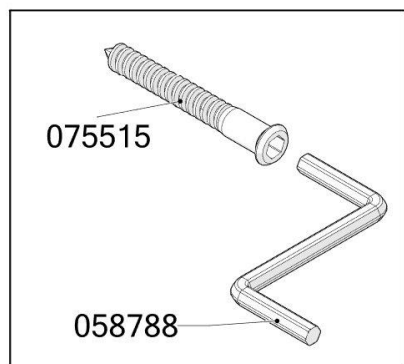

Cód.	Qtde.
058788	1
075515	4

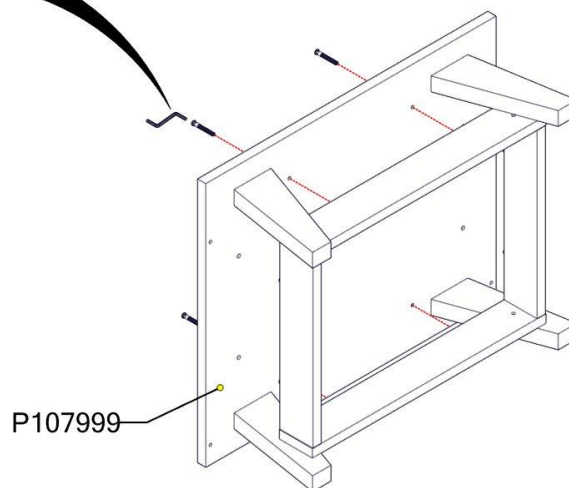

## STEP 19

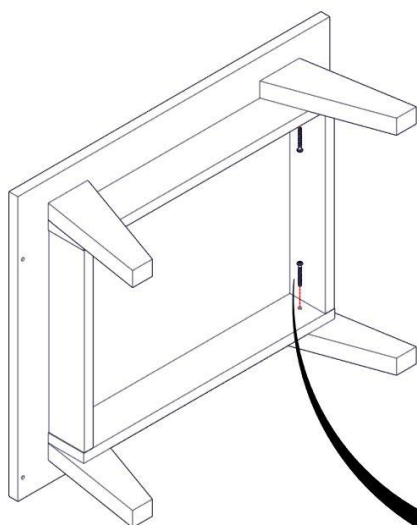

Cód.	Qtde.
000414	4

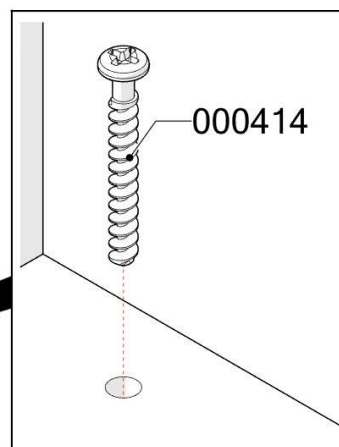

## STEP 20

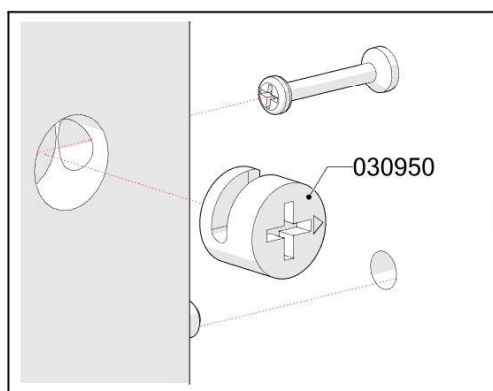

Cód.	Qtde.
030950	4

**PLEASE ENSURE THAT THE FRONT OF THESE PARTS/FURNITURE IS FACING TOWARDS THE GROUND AS THIS WILL REDUCE MOVING THE FURNITURE AROUND IN FUTURE STEPS.**

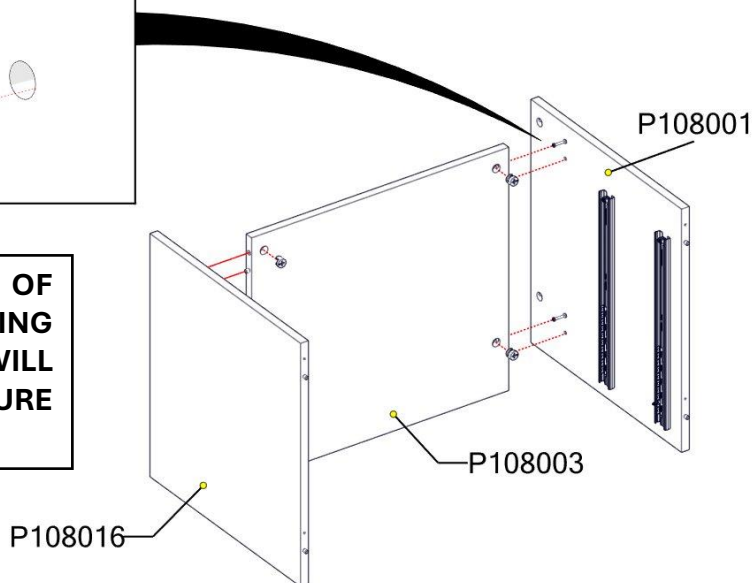

## STEP 21

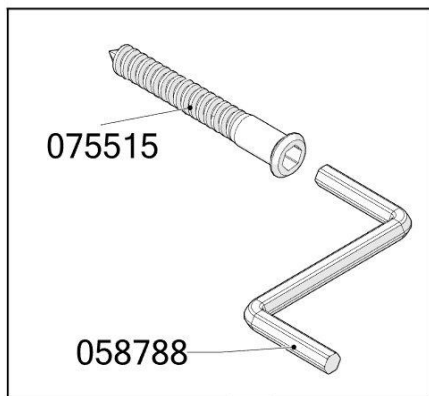

Cód.	Qtde.
058788	1
075515	4

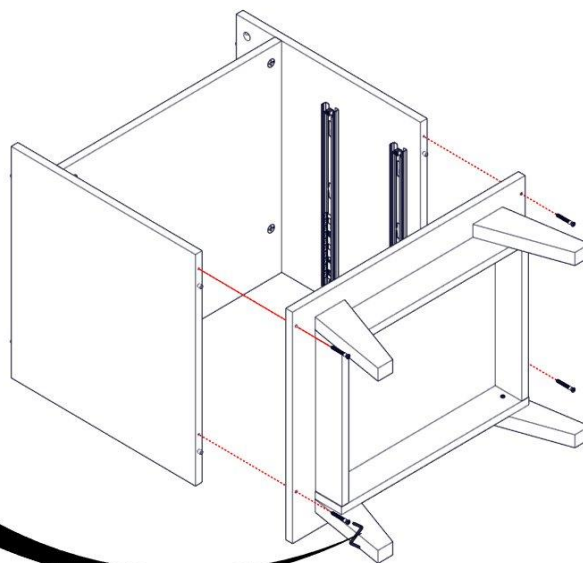

## STEP 22

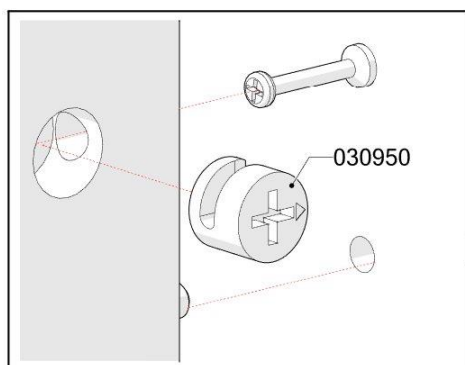

Cód.	Qtde.
030950	4

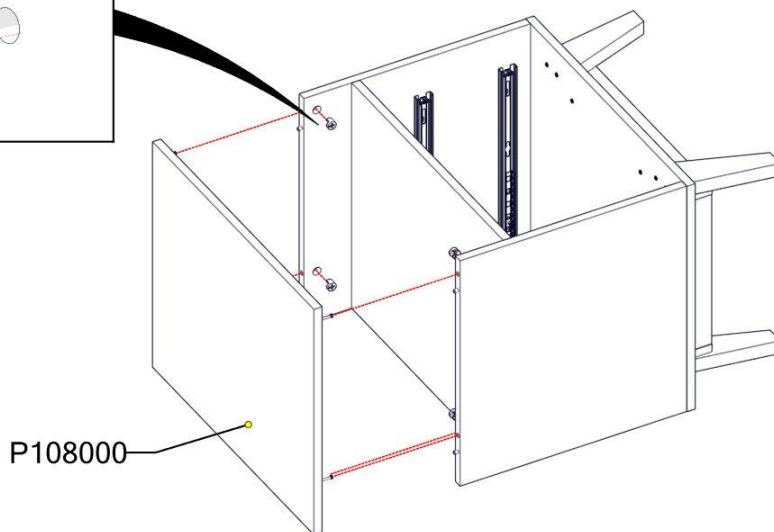

## STEP 23

Note: It is essential to place the furniture backing straight/ squared to avoid problems with the functioning and alignment of the doors.

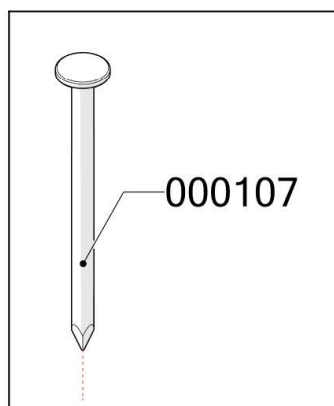

After checking that the back panel is squared to the side and top, nail the back panel in place.

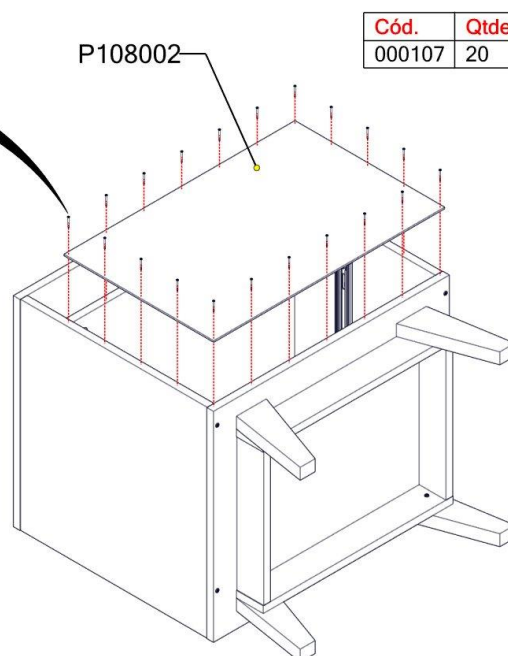

Cód.	Qtde.
000107	20

## STEP 24

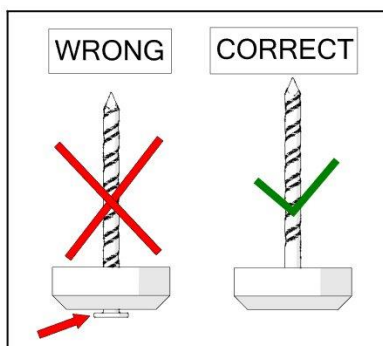

Cód.	Qtde.
000108	4
001901	4

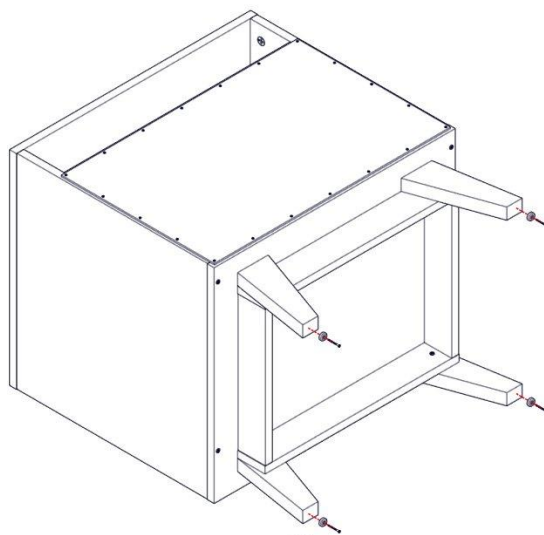
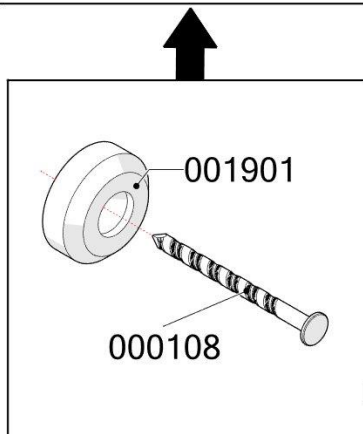

## STEP 25

Cód.	Qtde.
19MM	4

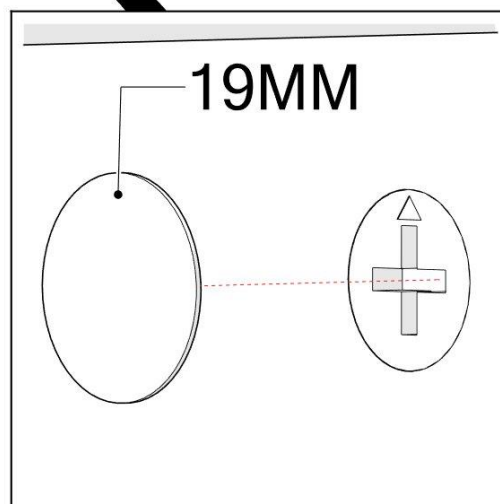

## STEP 26

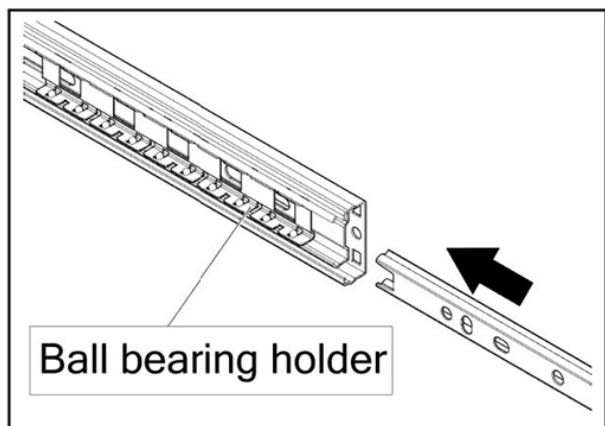
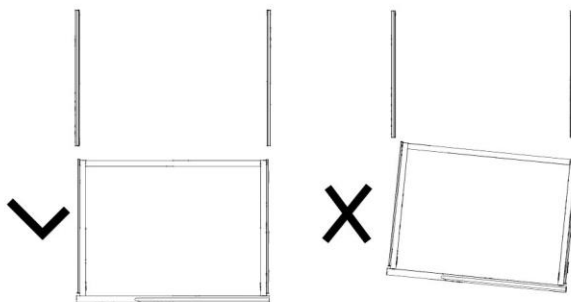
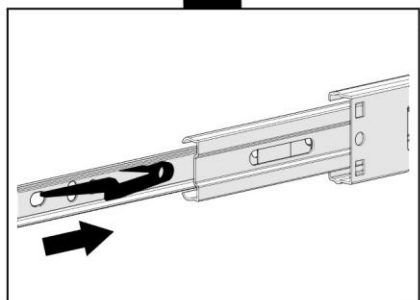
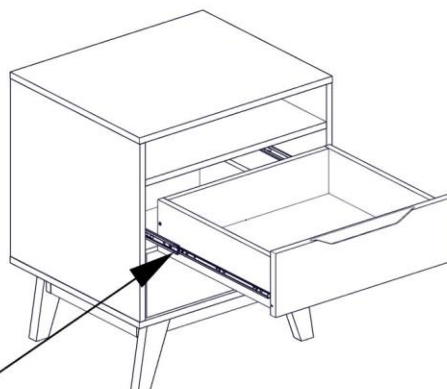
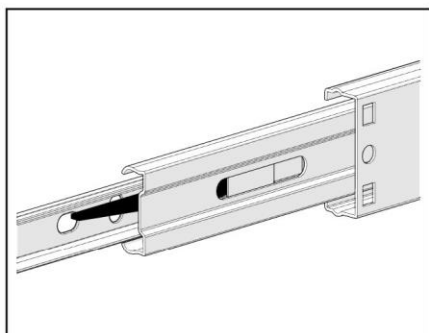

### Piece illustration

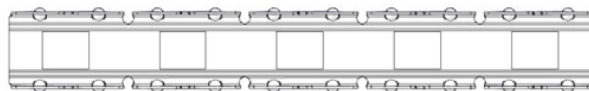

For the telescopic slide to work properly, it is extremely important that the ball bearing holder is pulled forward in the section it is found. This way the drawer will properly slide into place.

## STEP 27

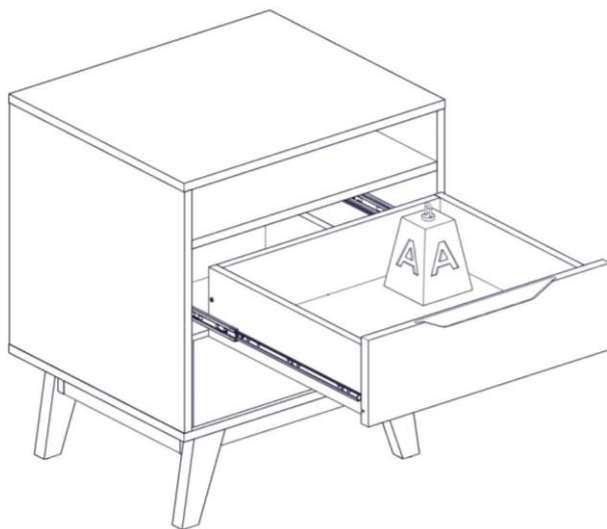

### Weight supported

Maximum load weight illustrated in the drawing distributed from uniform way.

	KG	LB
A	6	13,23

## STEP 28

**NOTE: Do not turn the DRYWALL ANCHOR into a 10 fasten the SAFETY ANTI-TIPPING**

Compress the wings of anchor before inserting.

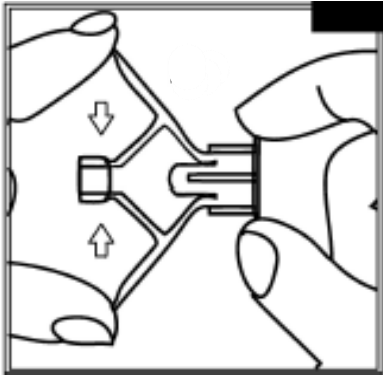

Insert the chuck into the hole of the base material.

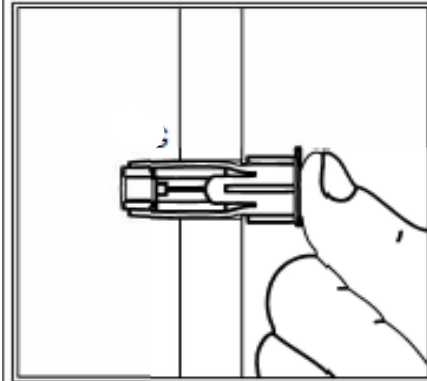

Position the object over the bushing and secure it with a screw.

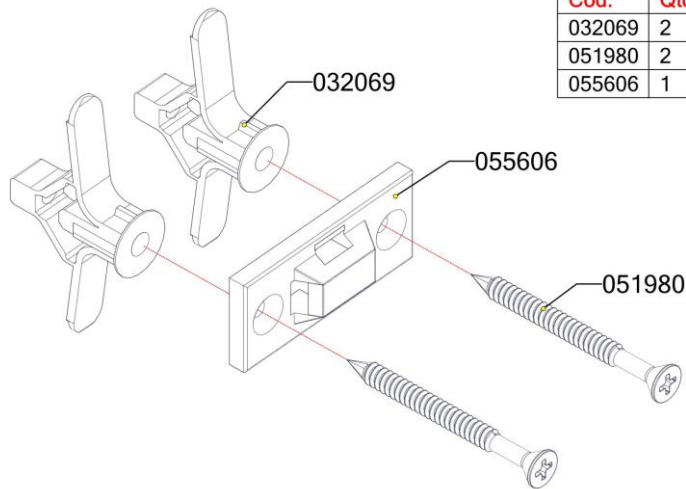
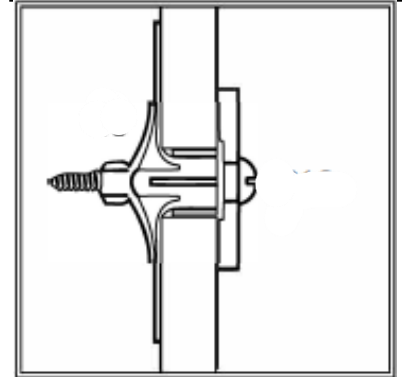

Cód.	Qtde.
032069	2
051980	2
055606	1

### Important

The minimum length of the screw must be the bushing length + object thickness that will be fixed.

To guarantee the wing expansion function of the bushing, after the screw head is at the object to be fixed, one must continue to rotate the screw until maximum torque is reached.

Pierce the base material a 0.39 in. drill.



## STEP 29

1ST

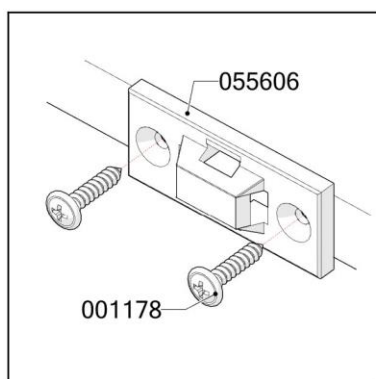

Cód.	Qtde.
001178	2
055606	1
055607	1

2ND

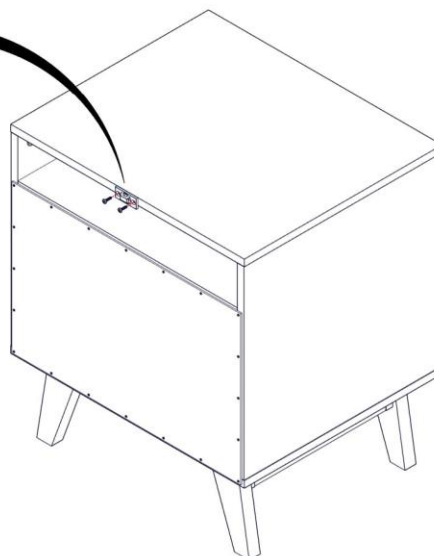
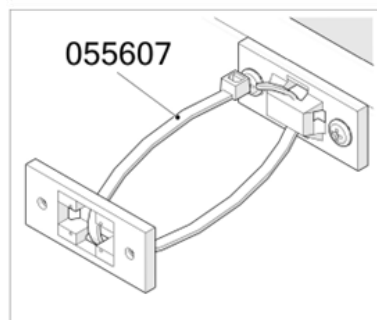

### A WARNING – Anti-Tip Advisory

Potential of serious fatal crushing injuries may occur from furniture tip-over. To help prevent tip-over:

ALWAYS INSTALL the tip-over restrain that came with your furniture. This tip-over restrains only reduces but does NOT completely eliminate the risk of tip-over

- ALWAYS Place the heaviest items in the lowest/bottom drawer.
- NEVER place heavy objects on top of this product.
- NEVER allow children to scale/climb/hang on the drawers, doors, or shelves.
- NEVER open more than one drawer at a time.

### B ADVERTENCIA - Aviso antivuelco

Pueden producirse lesiones graves por aplastamiento mortales debido al vuelco de los muebles. Para ayudar a prevenir vuelcos:

- SIEMPRE INSTALE el sistema de retención que viene con sus muebles. Este sistema antivuelco solo reduce pero NO elimina por completo el riesgo de vuelco.
- SIEMPRE coloque los artículos más pesados en el cajón más bajo /inferior.
- NUNCA coloque objetos pesados encima de este producto.
- NUNCA permita que los niños escalen, trepen o se cuelguen de los cajones, puertas o estantes.
- NUNCA abra más de un cajón a la vez