

STEP 5

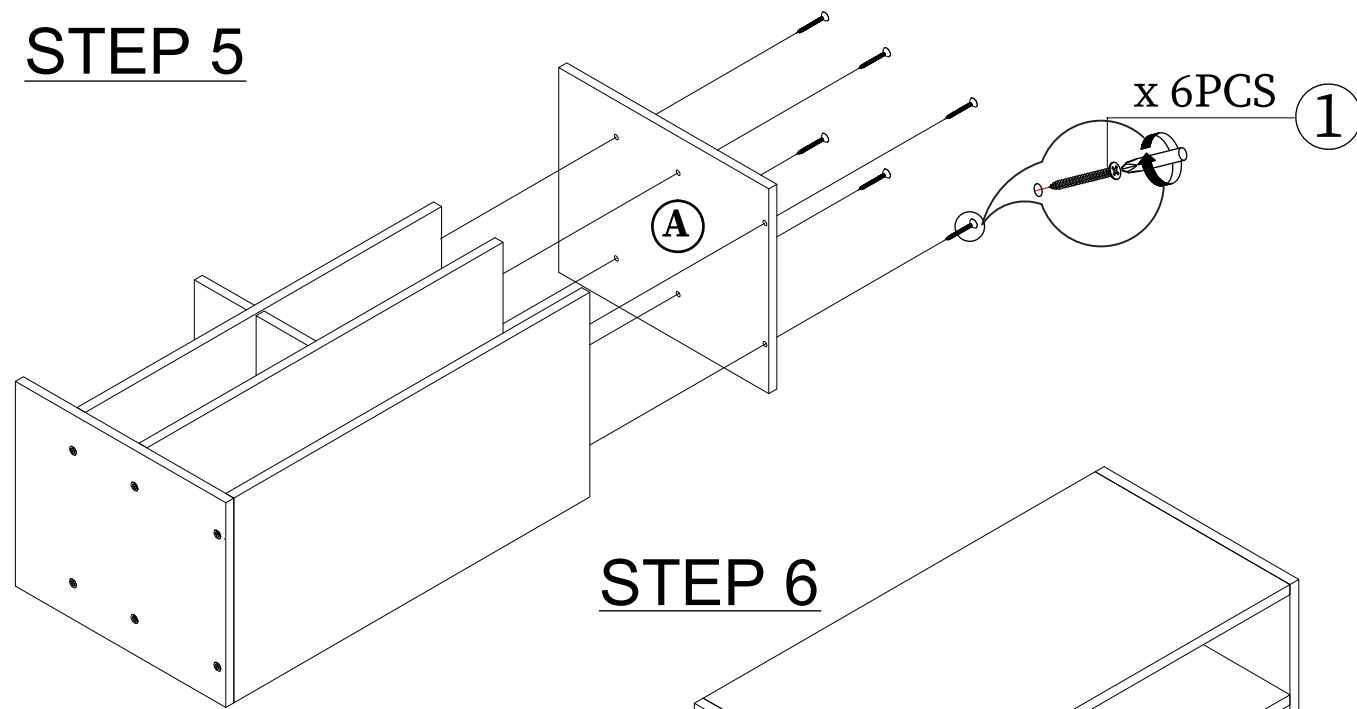

STEP 6

TURN 90°

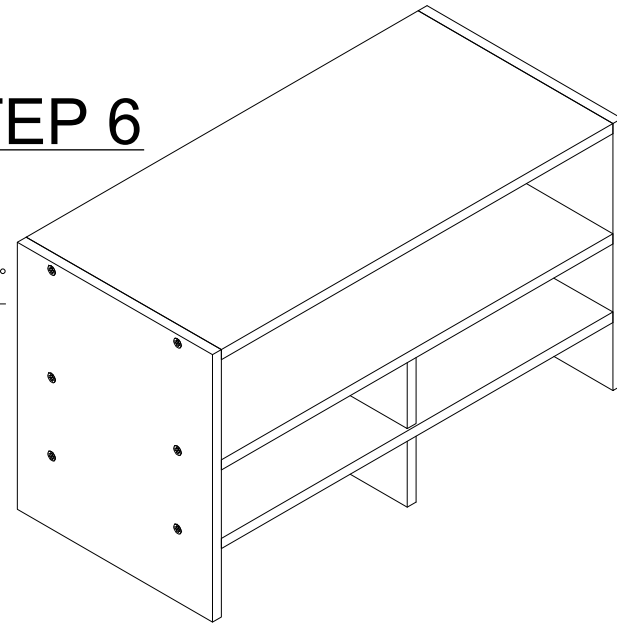

Recommended Maximum Weight

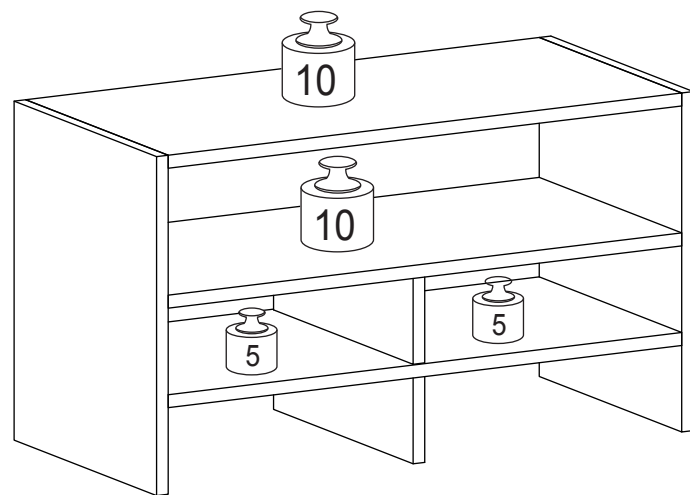

No Sitting

*Unit in Pound(lbs.)

WARNING:

>This unit has been designed to support the maximum loads shown. Exceeding these load limits could cause sagging, instability, product collapse, and/or serious injury.

>DO NOT allow children to climb on unit.

> Put heavier items on lower shelves.

Assembly Instruction

Desk Top Organizing Shelf

00:15

Approx. 15 minutes





Recomm. 1 Person

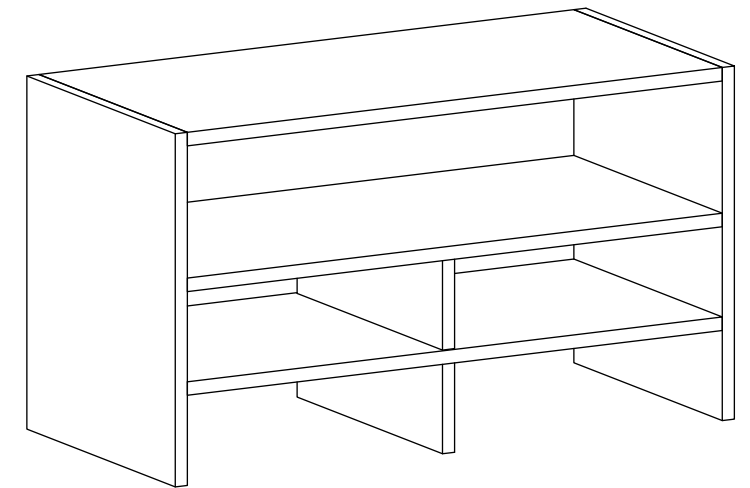

Tool Required



HARDWARE & PARTS LIST

NO	HARDWARE LIST	QTY
1	C/B SCREW 	12pcs
2	SHORT DOWEL 	2pcs
3	LONG DOWEL 	2pcs

NO	PART LIST	QTY
A	SIDE PANEL	2pcs
B	TOP PANEL	1pc
C	SHELF PANEL	1pc
D	BOTTOM PANEL	1pc
E	CENTER PANEL	2pcs

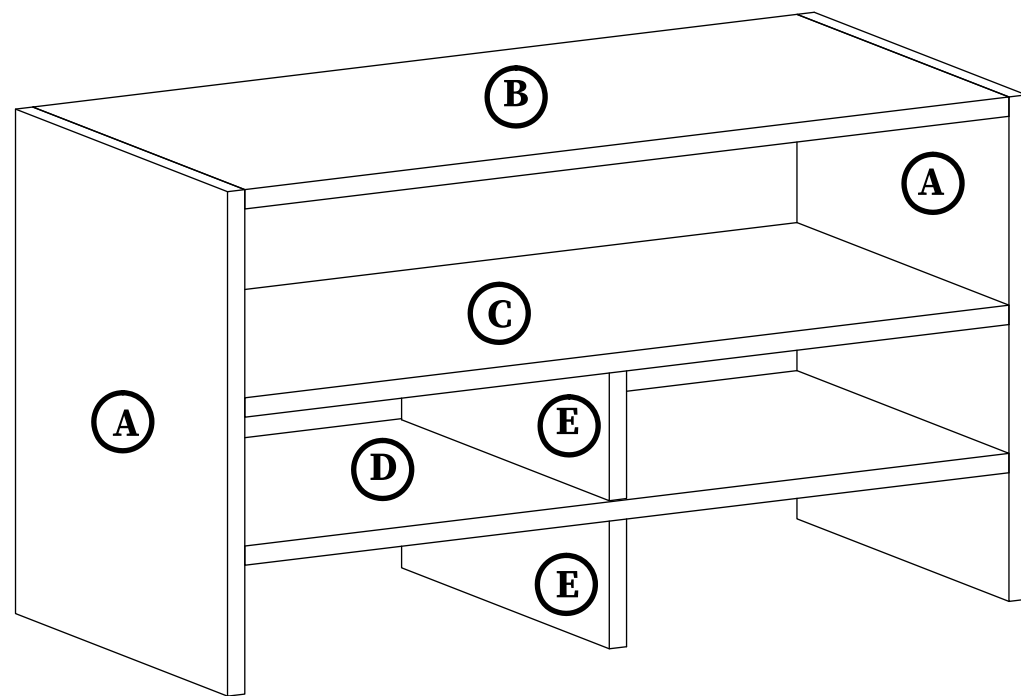

USEFUL HINTS BEFORE YOU START:

1. Read each step carefully before starting.
2. It is important that each step is performed in correct order to avoid difficulties.
3. Identify, sort and count the parts before assembly.
4. Assemble your furniture on packaging cardboard to prevent scratch or damage.
5. Clean the product with mild cleanser using soft dampened cloth. Do not use harsh or abrasive cleanser.
6. Using incompatible hardware might cause damage to product.

ASSEMBLY INSTRUCTIONS

BEFORE YOU BEGIN, PLEASE READ ASSEMBLY INSTRUCTIONS CAREFULLY, FOLLOW THEM STEP BY STEP.

STEP 1

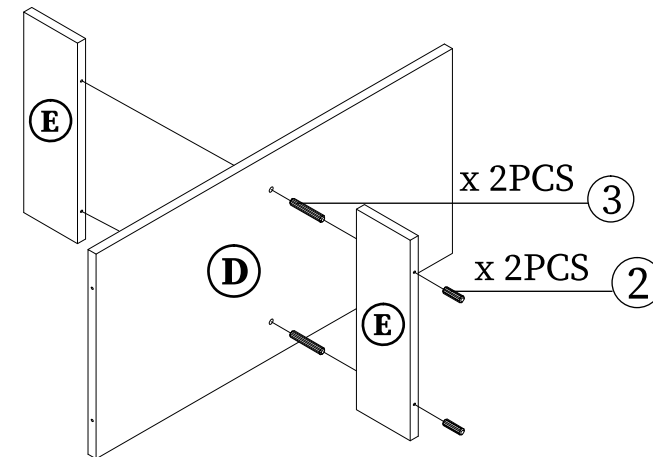

STEP 2

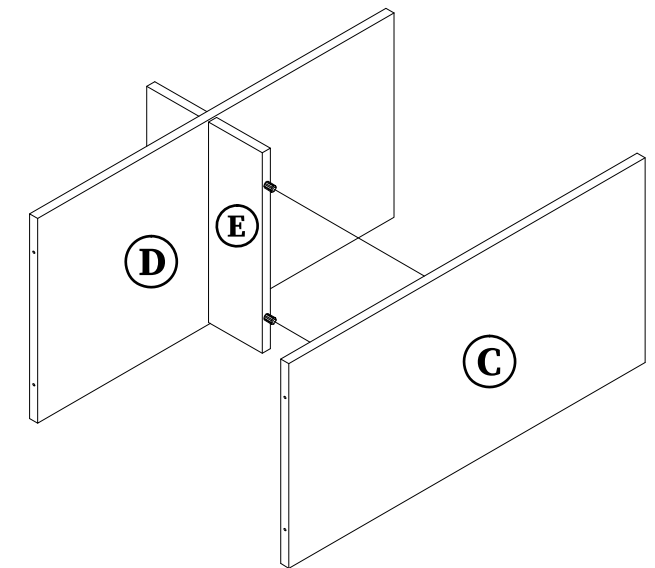

STEP 3

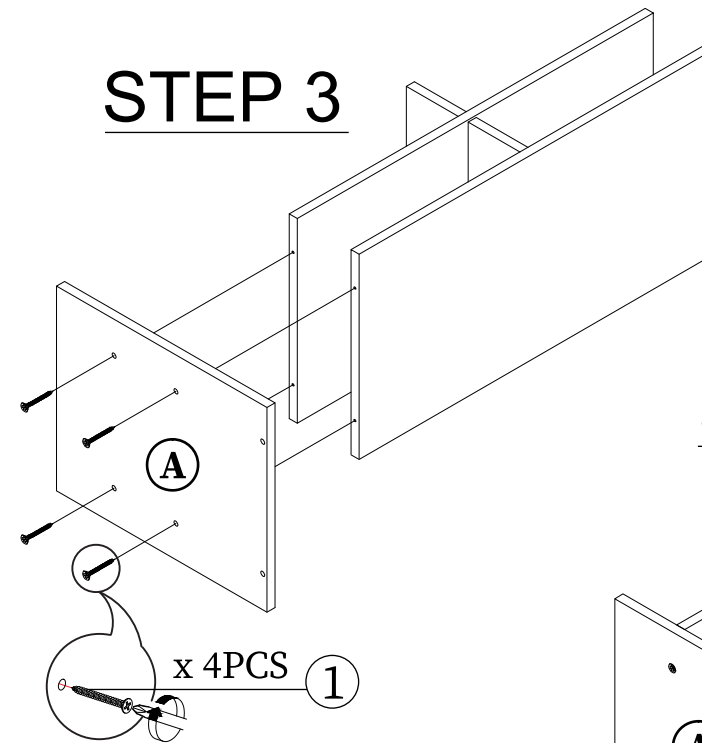

STEP 4

