

# INSTRUCTION MANUAL

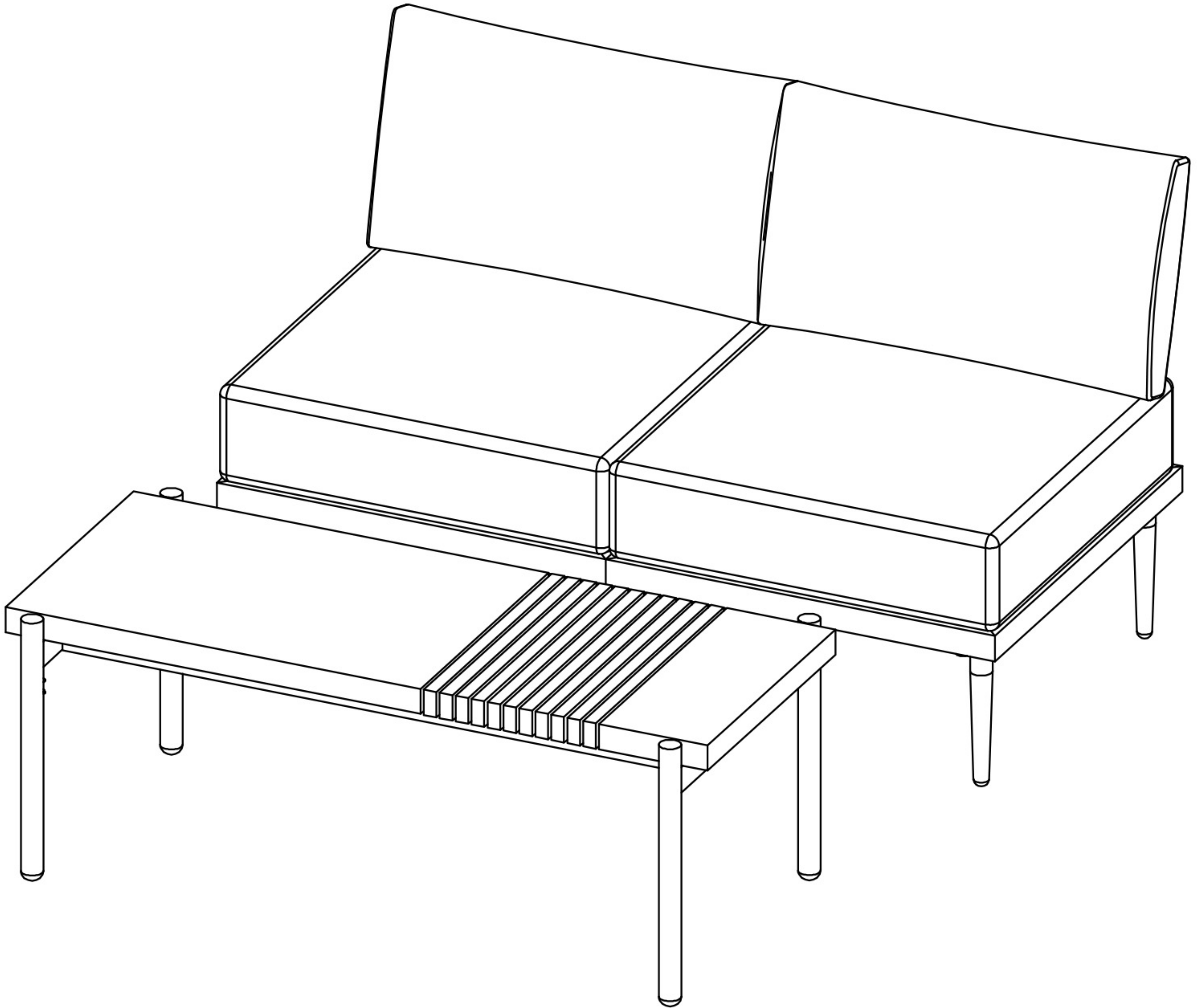

**2 Middle Sofas + 1 Coffee Table**

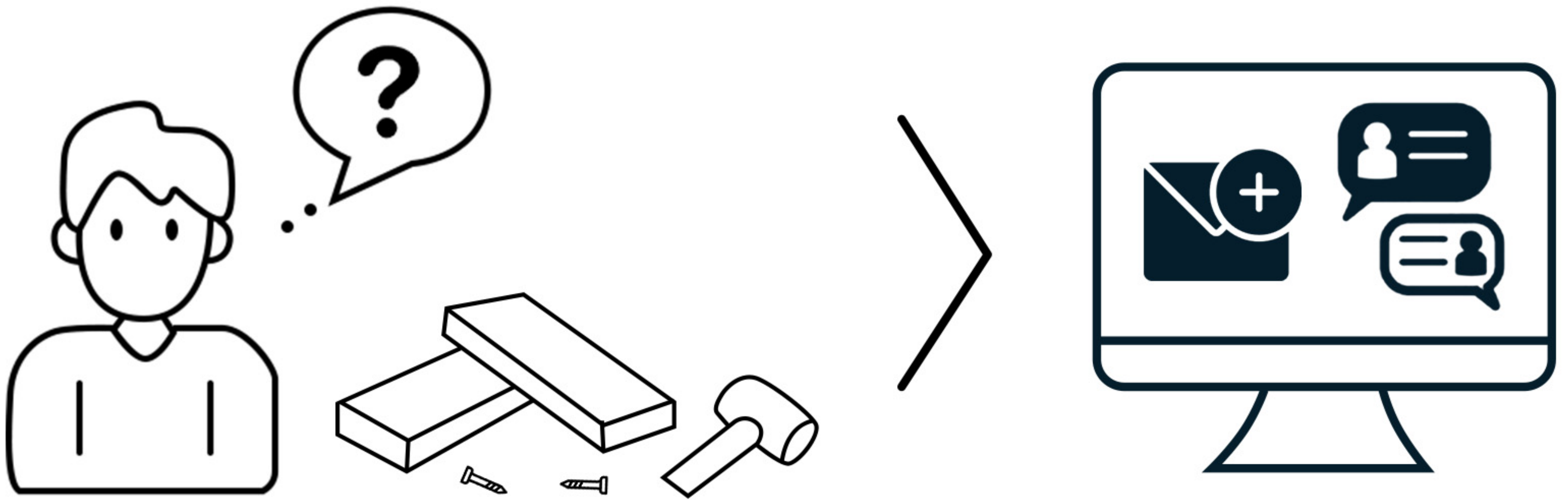

**Questions? Comments?**  
**Reach out to us for expert support!**



# READ & SAVE BELOW INSTRUCTIONS BEFORE ASSEMBLY

1. Choose a clean, flat workspace with enough space.
2. Check all parts and tools before starting.
3. Read the instructions fully and follow the steps in order.
4. Tighten screws loosely at first, then fully after alignment.
5. Work safely and ask for help with heavy parts.

## WARRANTY

- Thank you for purchasing our outdoor furniture, We are pleased to offer a one-year warranty on the quality of the product. This warranty covers any manufacturing defects or malfunctions that may occur within the first year of ownership.
- Exclusions: The warranty does not cover damages resulting from misuse , negligence, accidents, normal wear and tear, unauthorized repairs or modifications, improper assembly, or failure to adhere to the care and maintenance guidelines provided.

## MAINTENANCE AND CARE

- Protect it from extreme weather by moving it to a covered area or using furniture covers.
- Avoid dragging heavy objects on the furniture to prevent damage.
- Regularly inspect for wear or damage and address any issues promptly.
- Check and tighten hardware connections periodically.
- Use a damp cloth with warm soapy water or a suitable cleaning product to clean the furniture.
- Ensure proper drying after cleaning to prevent mold growth.

## CALIFORNIA PROPOSITION 65

**⚠️ WARNING:** This product can expose you to Carbon monoxide, which is known to the State of California to cause birth defects or other reproductive harm. For more information go to **[WWW.P65Warnings.ca.gov](http://WWW.P65Warnings.ca.gov)**

# PARTS

1. Before starting, double-check that all parts listed are included.
2. If any parts are missing or damaged, please contact us for assistance before assembly.
3. Keep small parts away from children to avoid choking hazards.
4. Organize the parts for easy access during assembly.

## PARTS

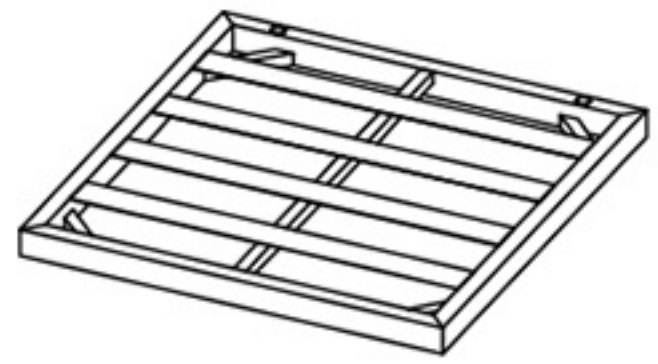

Seat Plate  
Ax2

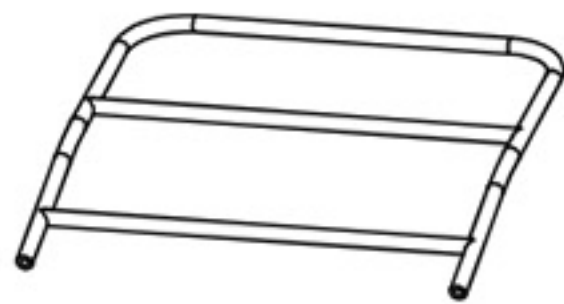

Backrest  
Bx2

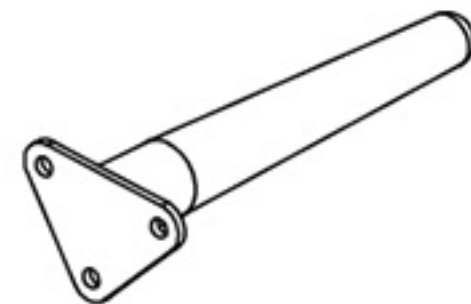

Support Leg  
Cx8

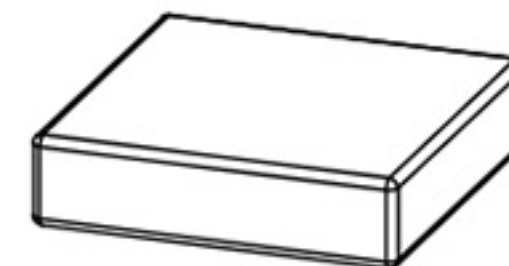

Seat Cushion  
Dx2

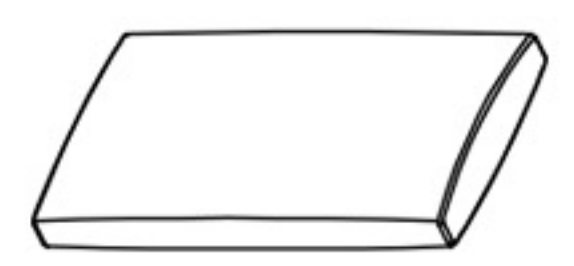

Back Cushion  
Ex2



Retention Strap  
Fx4

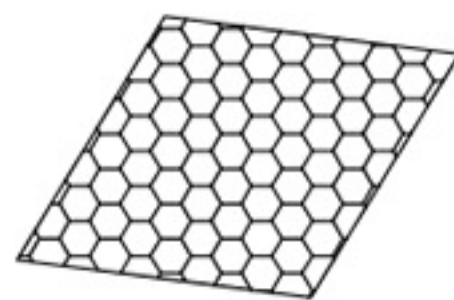

Grip Pad  
Gx2

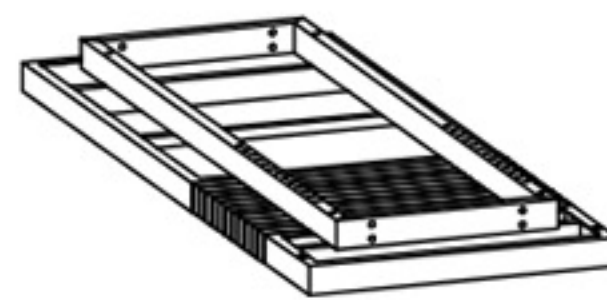
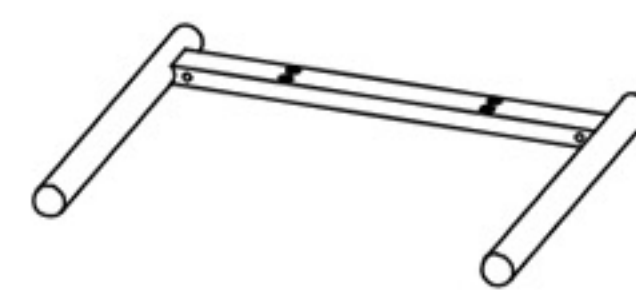
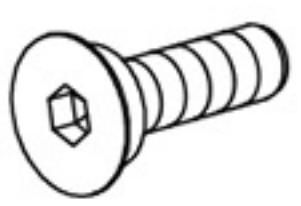

Table Top  
Hx1



Support Leg  
Jx2

## HARDWARES



Bolt M6\*15MM  
Kx4

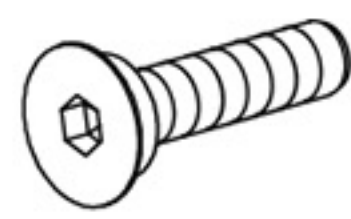

Bolt M6\*20MM  
Lx24

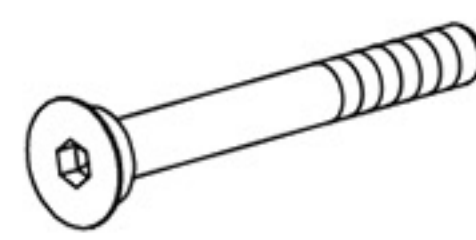

Bolt M6\*35MM  
Mx8

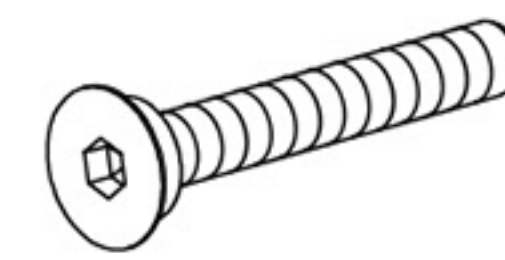

Bolt M6\*55MM  
Nx4



Washer  
Px40

## TOOL

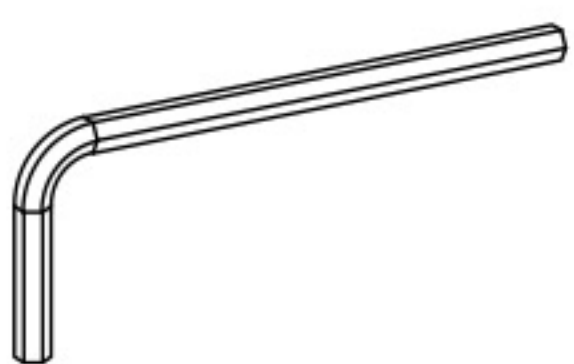

Allen Wrench



1 PERSON  
ASSEMBLY



UP TO 15 MIN.  
ASSEMBLY

# ASSEMBLY

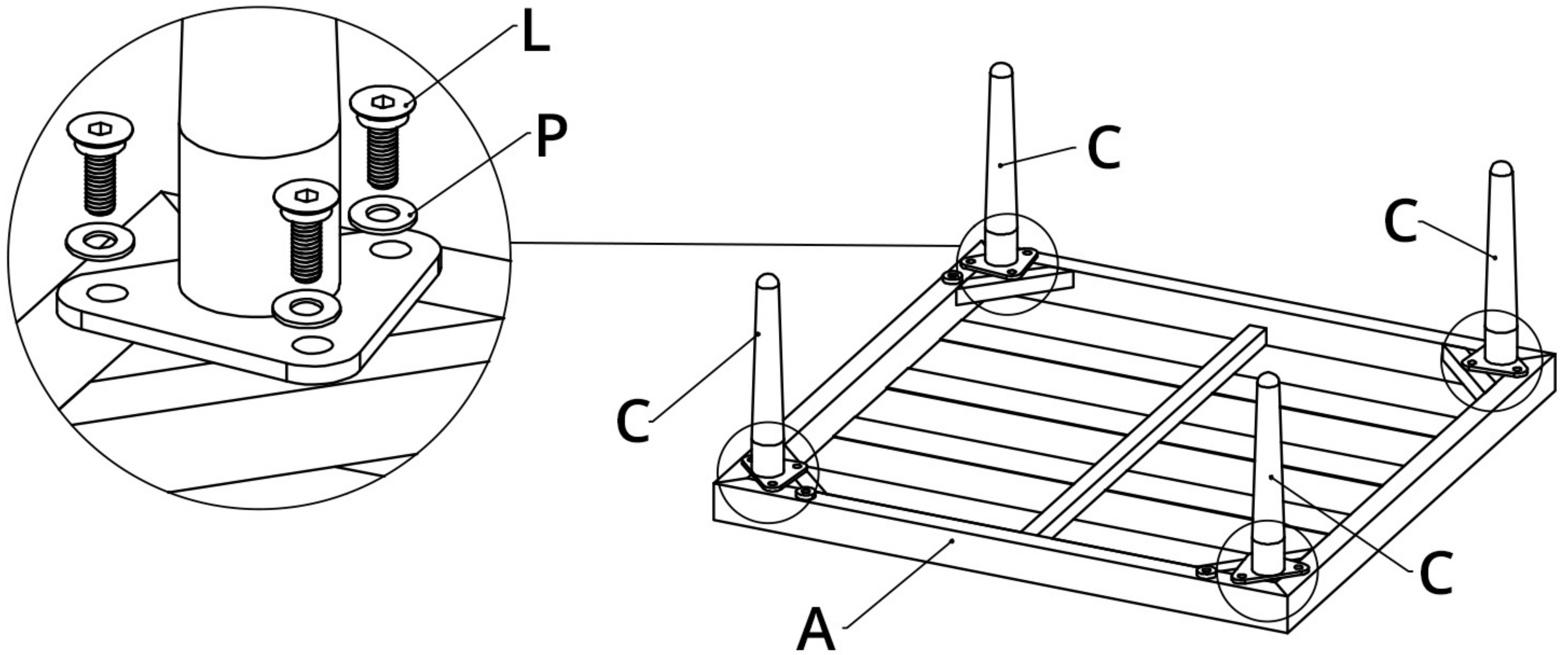

**1** Attach the Support Leg[C] to the Seat Plate[A] using Bolt M6\*20MM[L] & Washer[P].

**A** x2   **C** x8   **L** x24   **P** x24

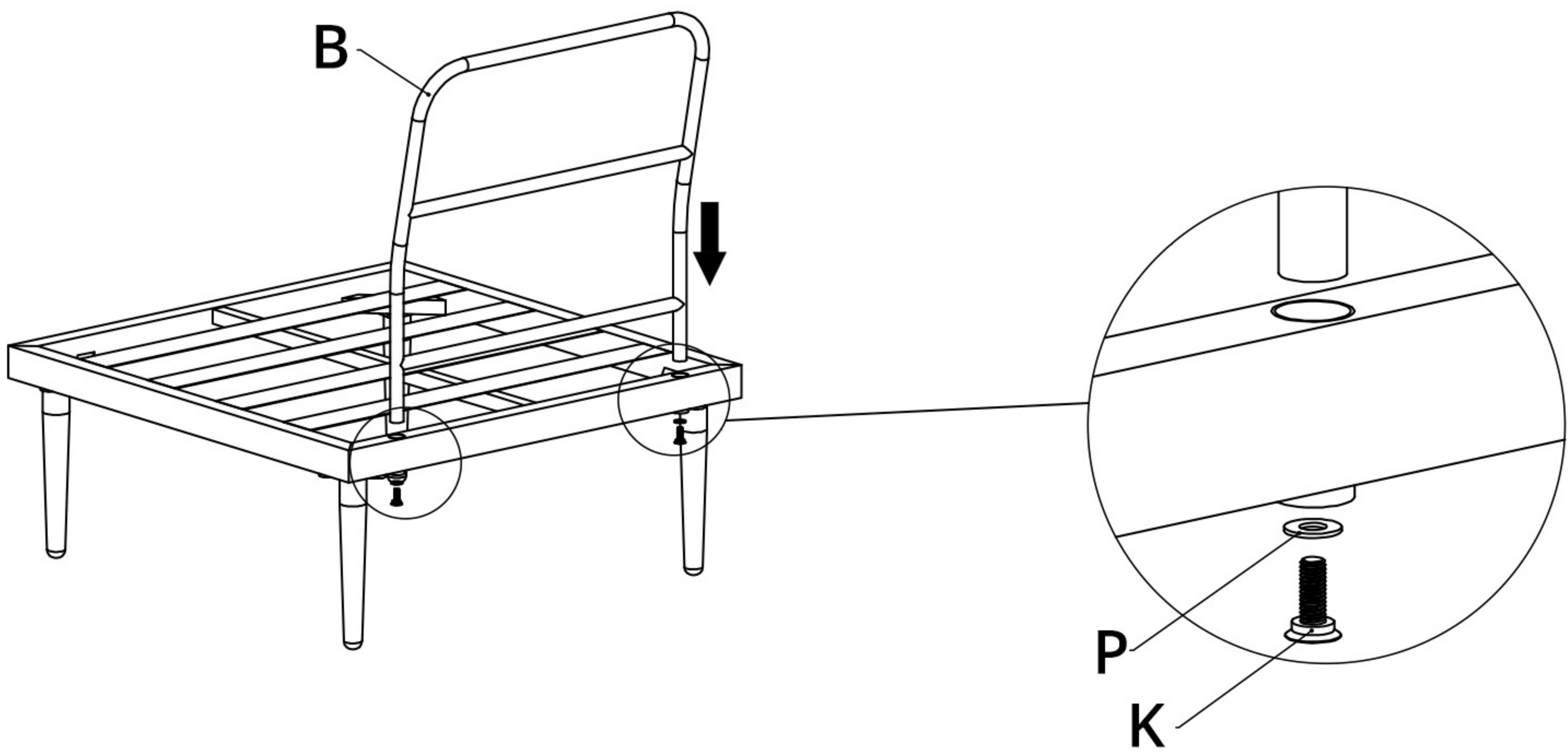

**2** Attach the Backrest[B] to the Seat Plate[A] using Bolt M6\*15MM[K] & Washer[P].

**B** x2   **K** x4   **P** x4

# ASSEMBLY

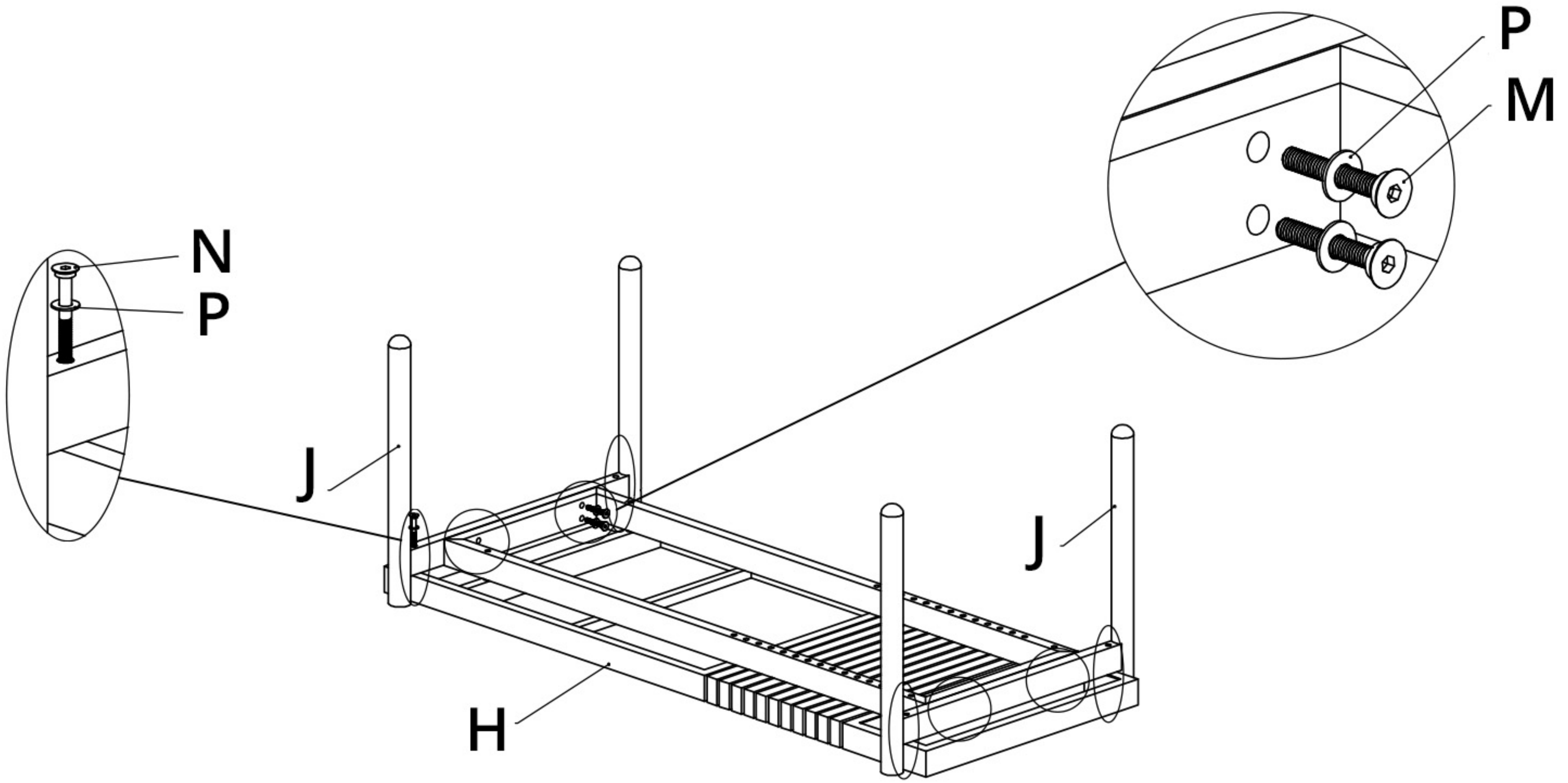

**3** Attach the Support Legs[J] to the Table Top[H] using Bolt M6\*35MM[M] & Washer[P] and Bolt M6\*55MM[N] & Washer[P].

**H** x1   **J** x2  
**M** x8   **N** x4   **P** x12

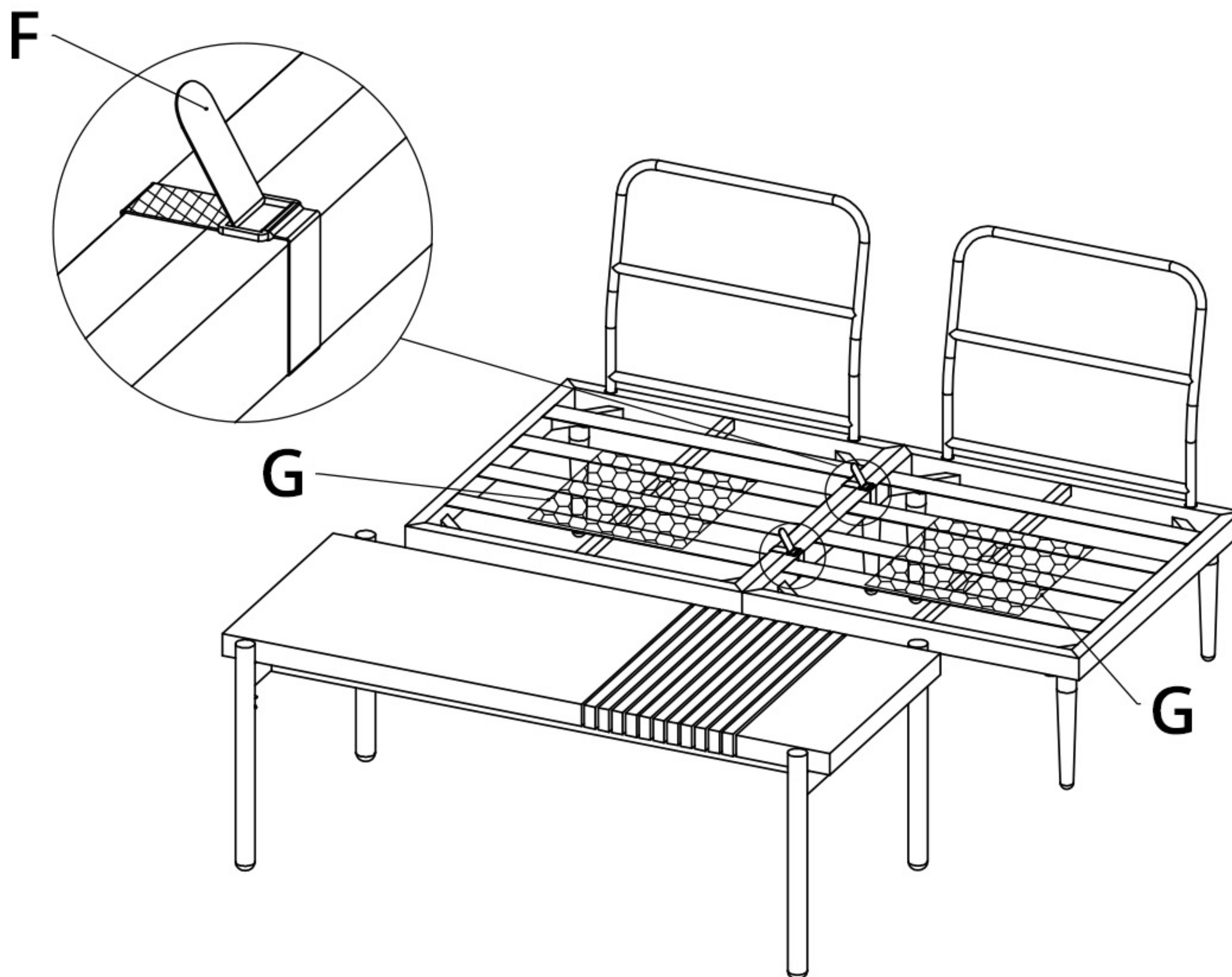

**4** -Join the Two Middle Sofas using Retention Strap[F].  
-Put the Grip Pad[G] on the the Seat Plate[A].

**F** x4   **G** x2

# ASSEMBLY

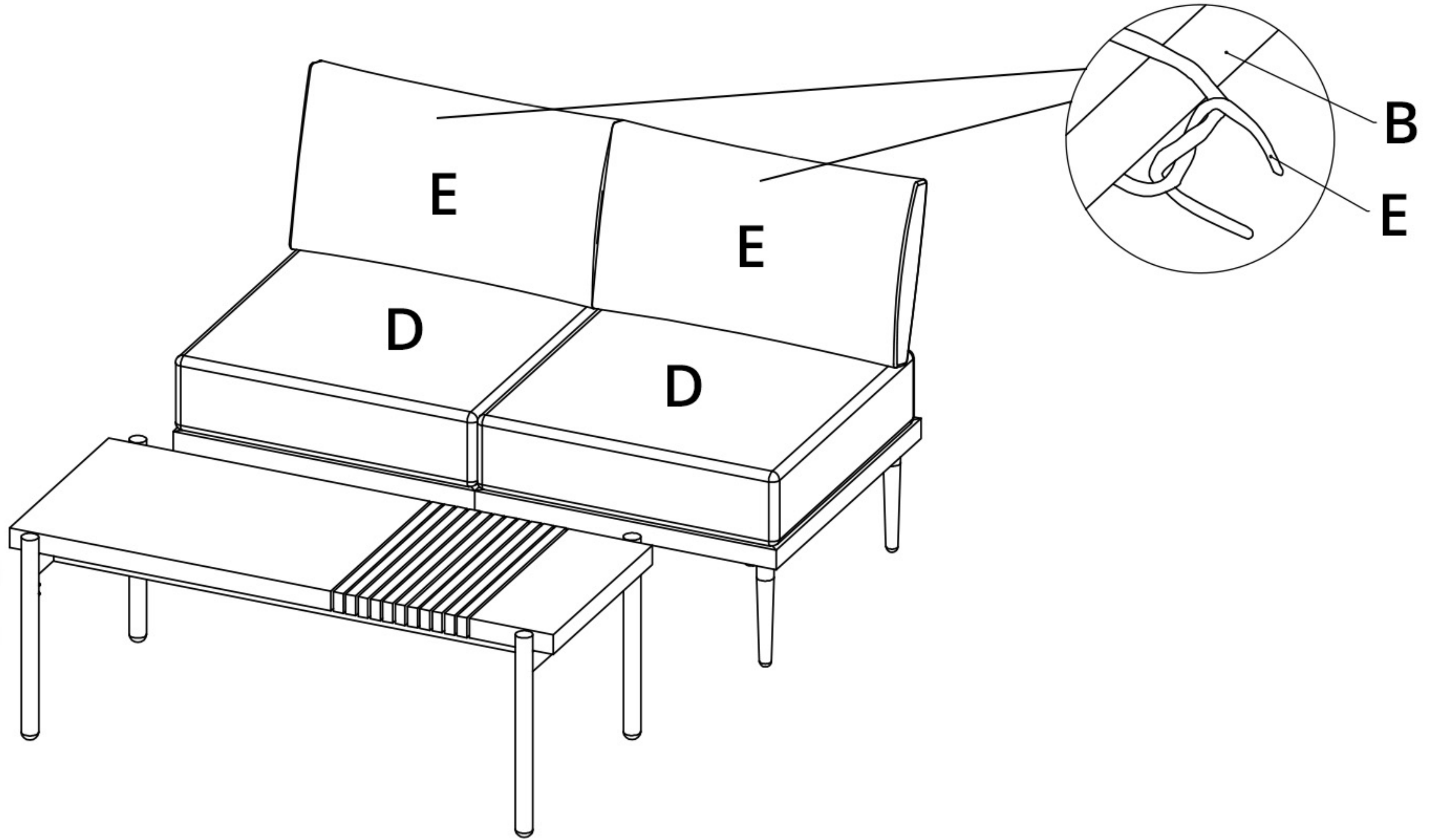

- 5** -Attach the Seat Cushion[D] and Back Cushion[E].  
-Tie the Straps of Back Cushion[E] to Backrest[B].

**D** x2 **E** x2