

File Cabinet

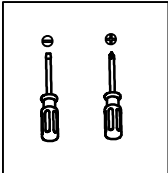

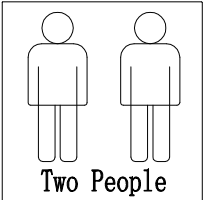
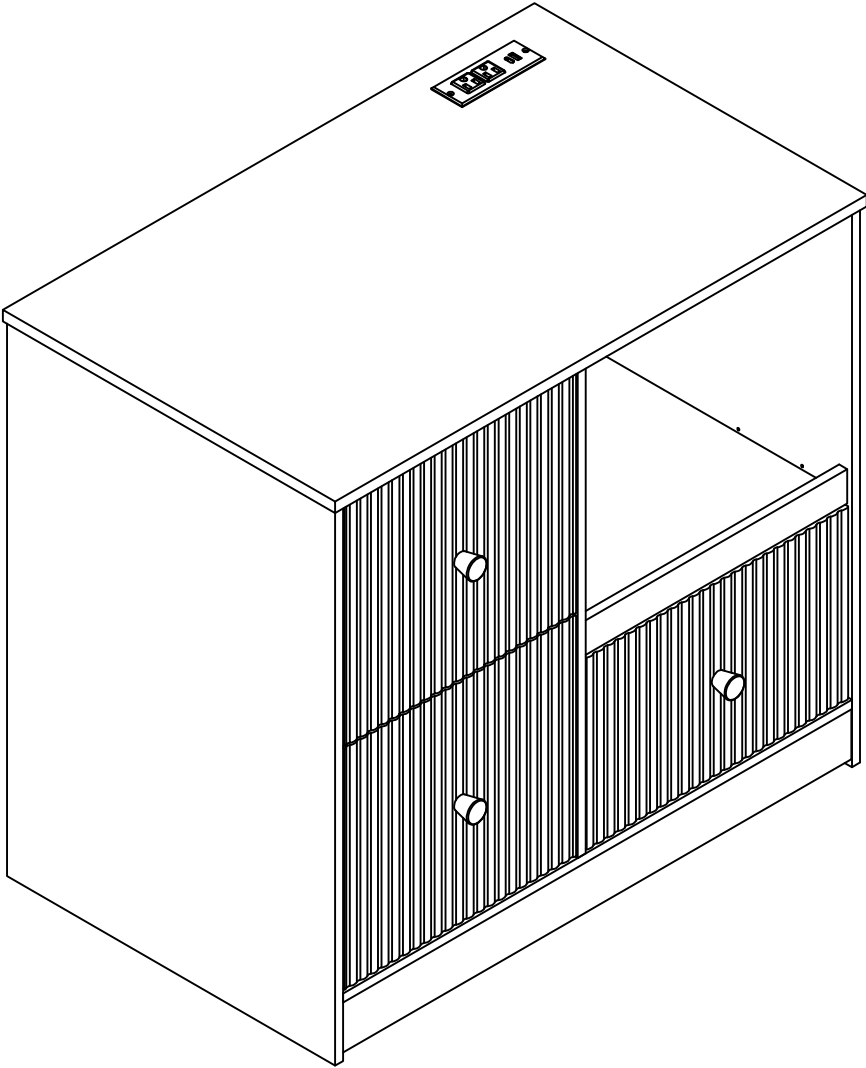
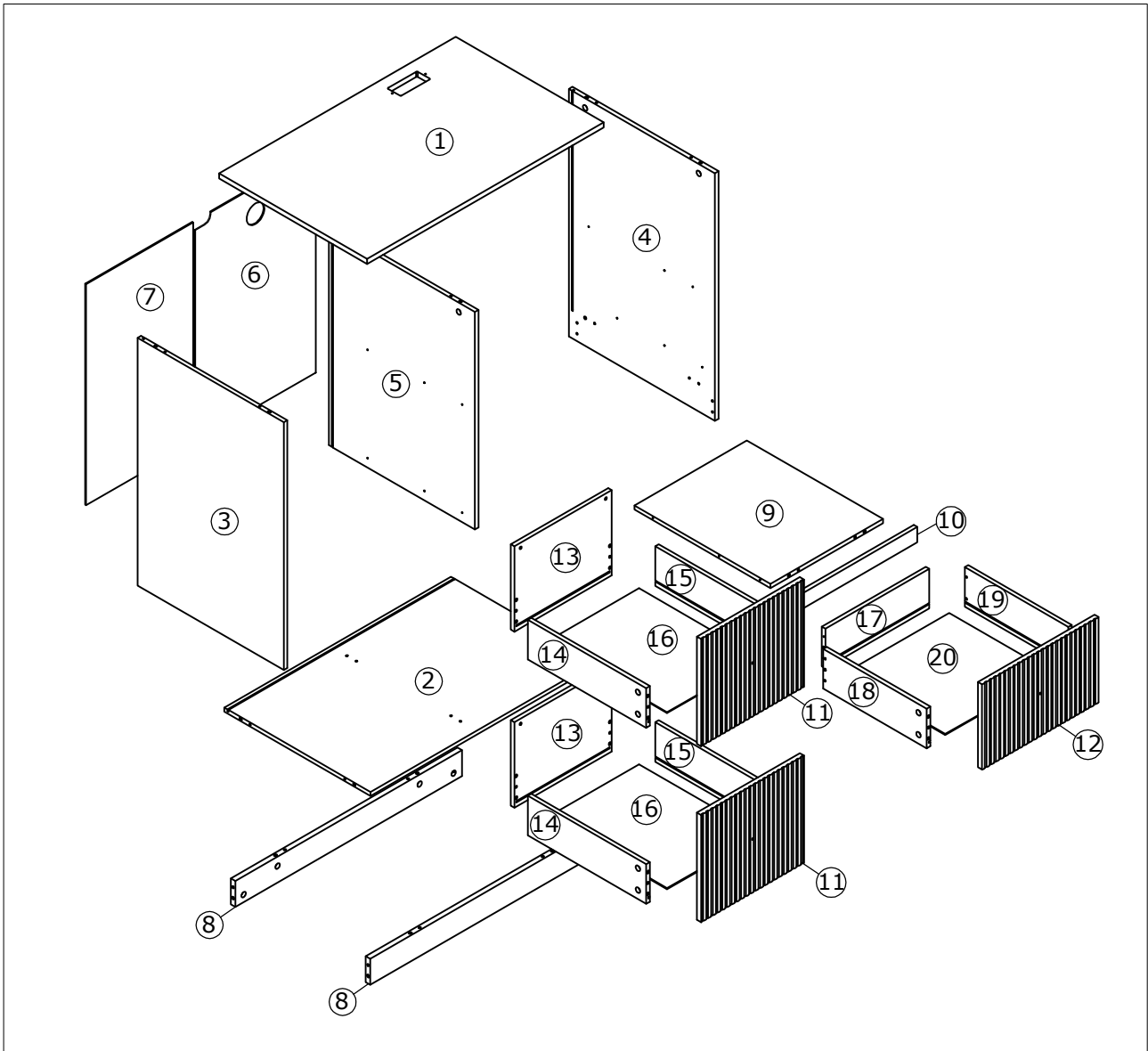

Parts Include

(A) x32 Ø6x27mm	(B) x32 Ø15x9.5mm	(C) x30 Ø6x30mm	(D) x50 Ø3.5x12mm	(E) x3 Ø20x21mm	(F) x3 Ø4x22mm
(G) x13 Ø4x30mm	(H) x8 Ø3x18mm	(I) x8 15*13*10mm	(J) x2 Ø5x48mm	(K) x1	(L) x2 L=400mm
(M) x1 L=350mm	(N) x2 L=450mm	(O) x4 Ø6x414mm	(P) x1 160x25mm	(Q) x2 Ø4x14mm	(R) x1

1 ▷

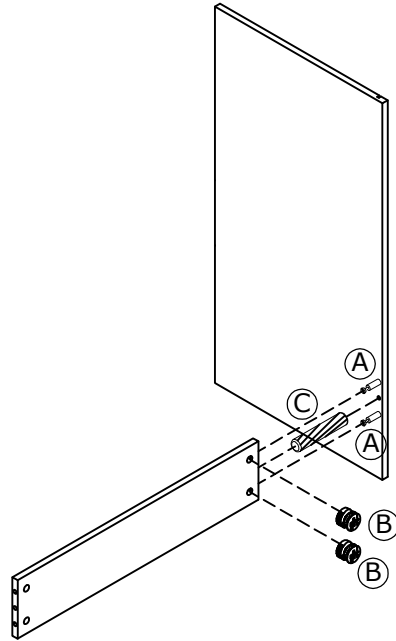

Installation Tips

During assembly, C (Wooden Dowels), A (Cam Screws), and B (Cam Lock Nuts) are used to connect the boards

Please follow the manual carefully to identify which holes are designated for C (Wooden Dowels) and which are for A (Cam Screws)

A (Cam Screws) and B (Cam Lock Nuts) work together to secure the parts. Please tighten B clockwise to lock

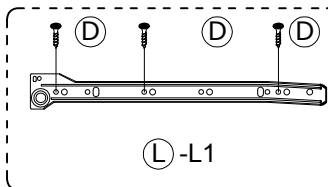

Ⓛ-L1

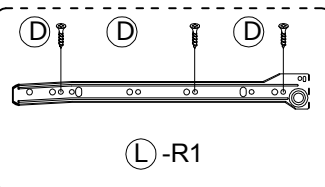

Ⓛ-R1

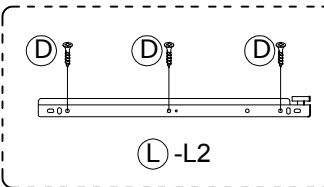

Ⓛ-L2

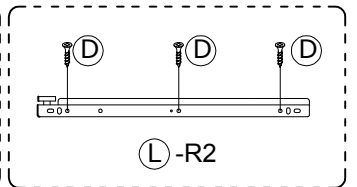

Ⓛ-R2

Ⓛ-L1

Left Outer Slide:
Installed on the left inner wall of the cabinet

Ⓛ-R1

Right Outer Slide:
Installed on the right inner wall of the cabinet

Ⓛ-L2

Left Inner Slide:
Installed on the left side of the drawer

Ⓛ-R2

Right Inner Slide:
Installed on the right side of the drawer

2 ▷

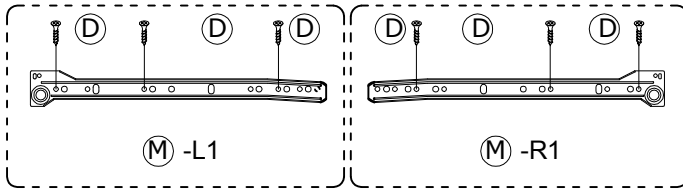

(M) -L1

Left Outer Slide:
Installed on the left inner wall of the cabinet

(M) -R1

Right Outer Slide:
Installed on the right inner wall of the cabinet

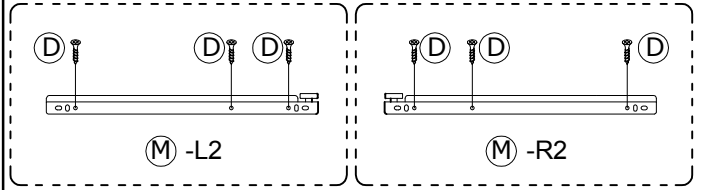

(M) -L2

Left Inner Slide:
Installed on the left side of the drawer

(M) -R2

Right Inner Slide:
Installed on the right side of the drawer

3 ▷

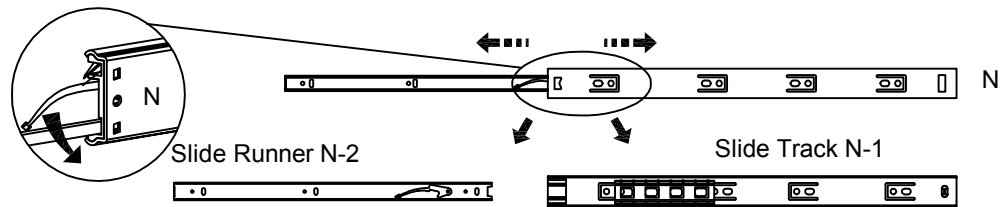

Separate the 2 sets of Slide Runners (N-2) and Slide Tracks (N-1) from Slides (N) by following the steps below:
Extend the Slide Runner all the way forward.
Press the plastic release lever of the slide down and pull the Slide Runner (N-2) completely out.

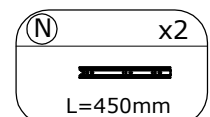
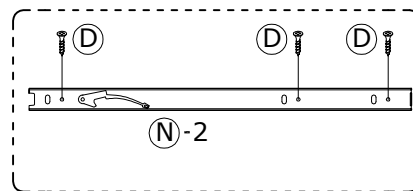
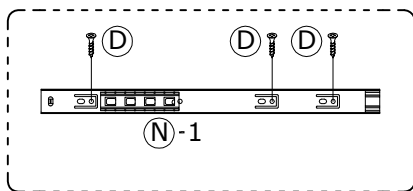

4 ▶

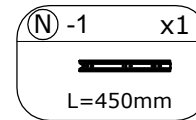
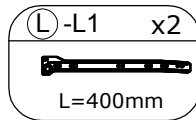
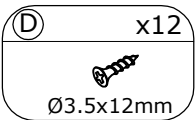
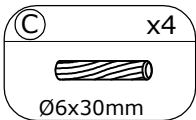
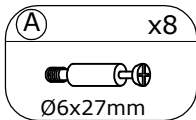
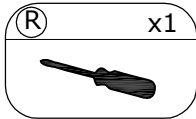
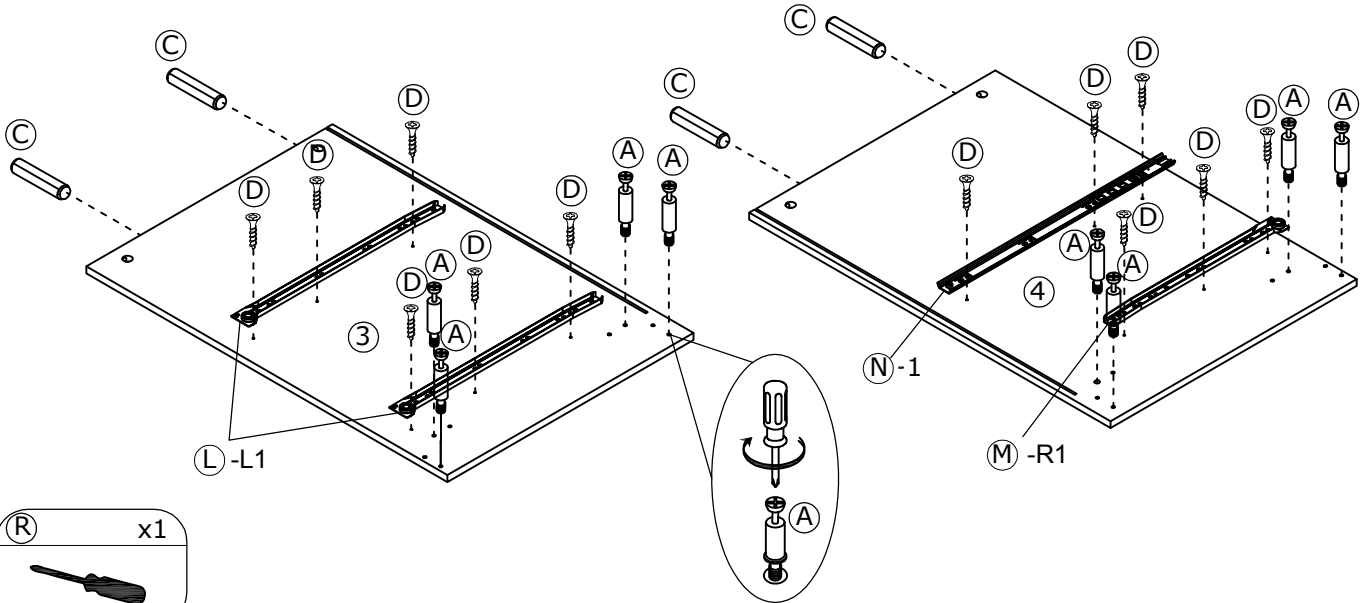
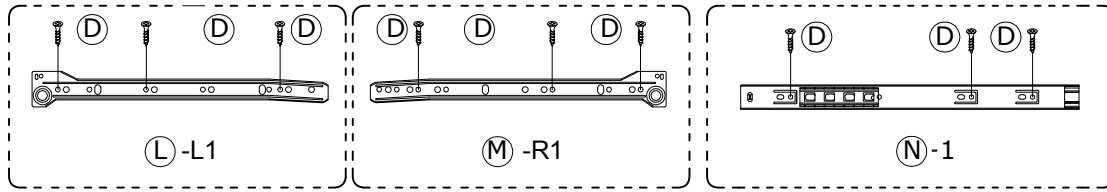

5 ▶

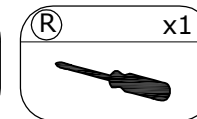
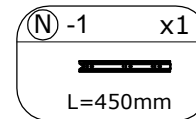
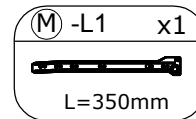
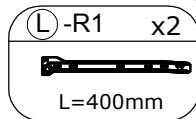
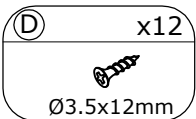
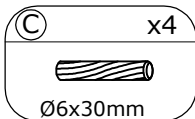
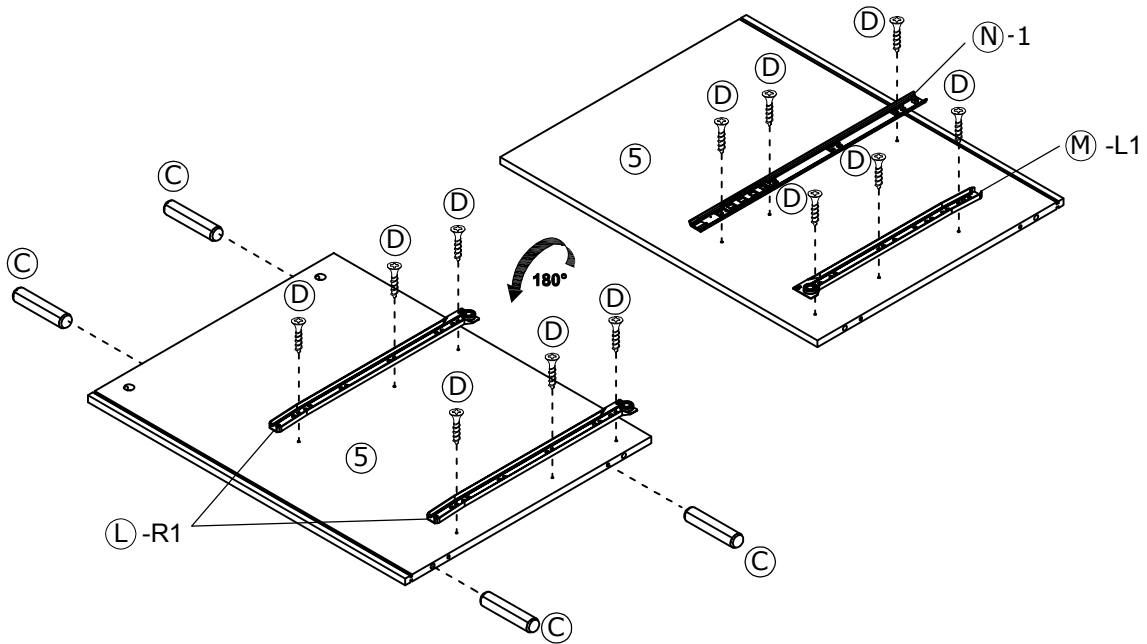
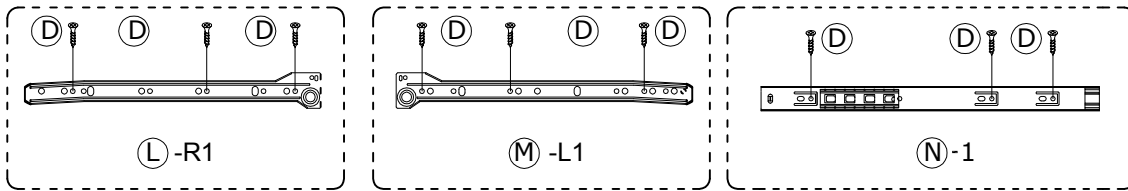

6 ▷

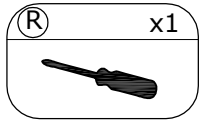
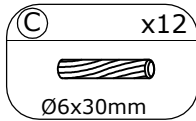
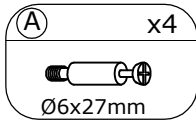
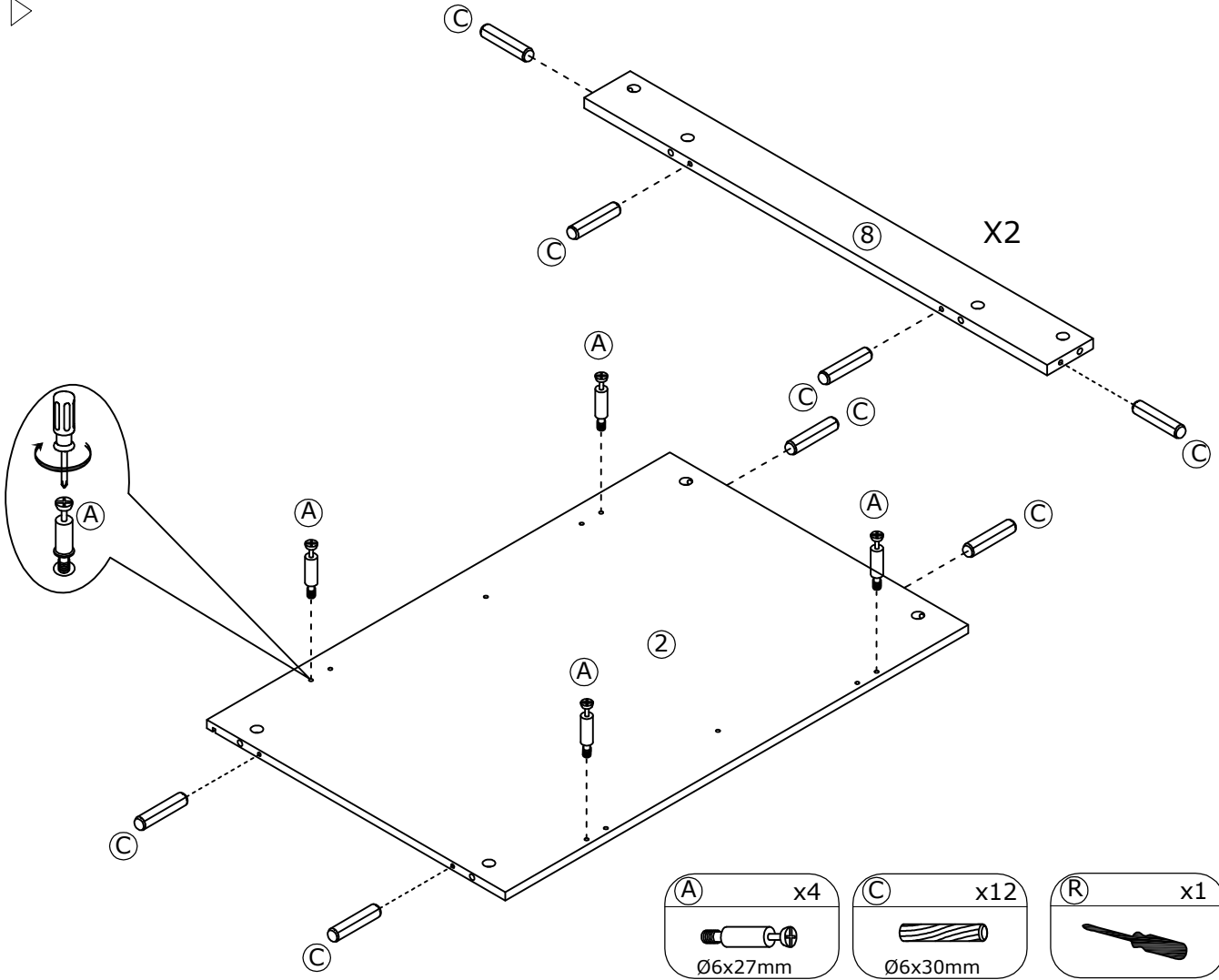

7 ▷

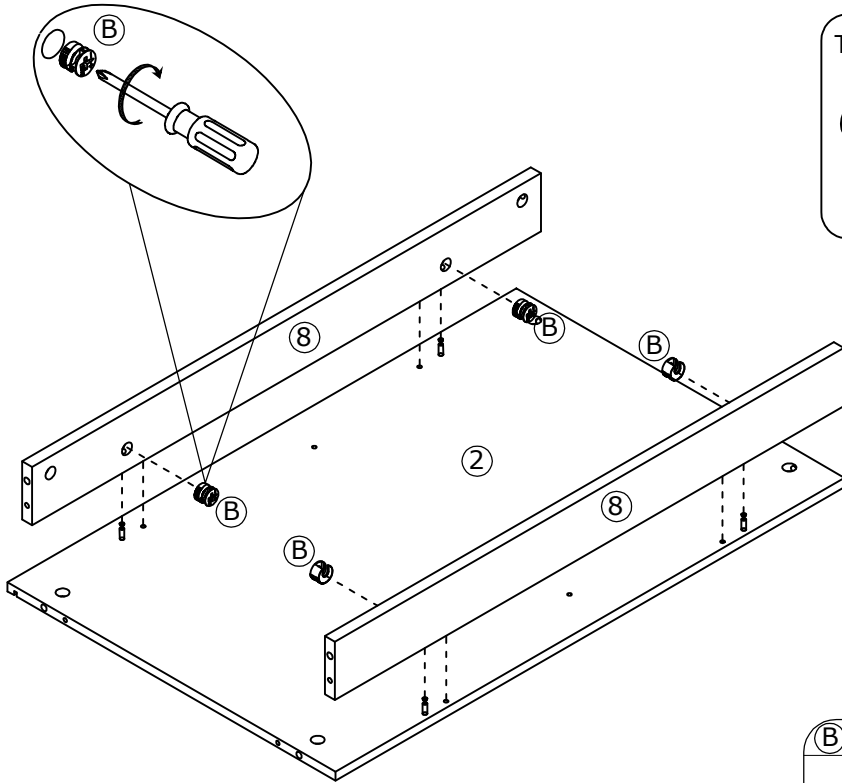

This is how a cam nut works.....

The head of the cam bolt goes into the open mouth of the cam nut. You then turn the cam nut so it tightens over the bolt.

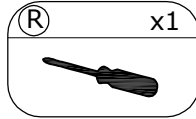

8 ▷

This is how a cam nut works.....

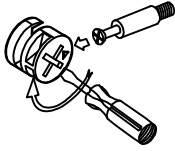

The head of the cam bolt goes into the open mouth of the cam nut. You then turn the cam nut so it tightens over the bolt.

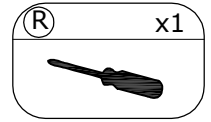
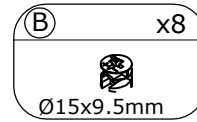
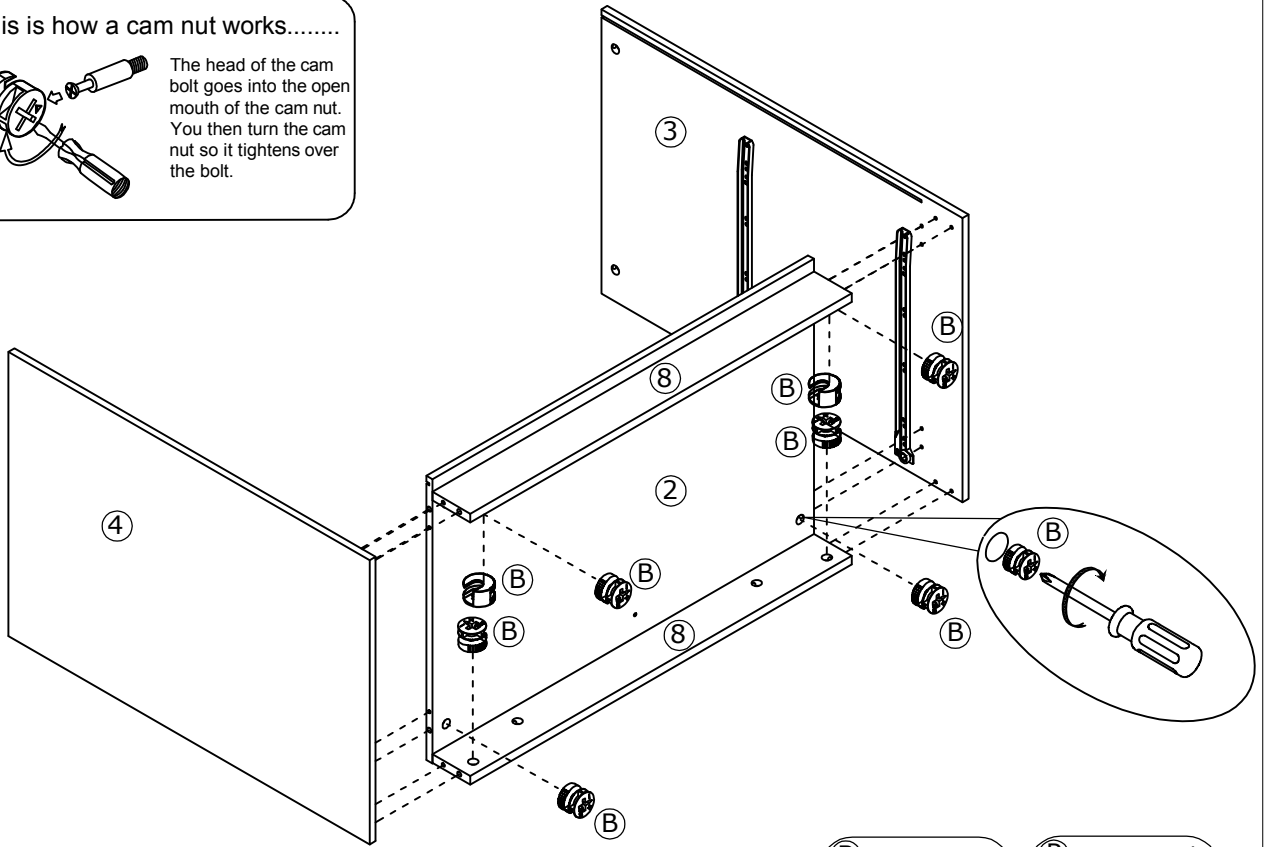

9 ▷

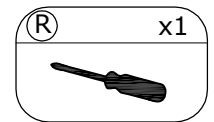
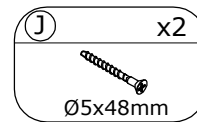
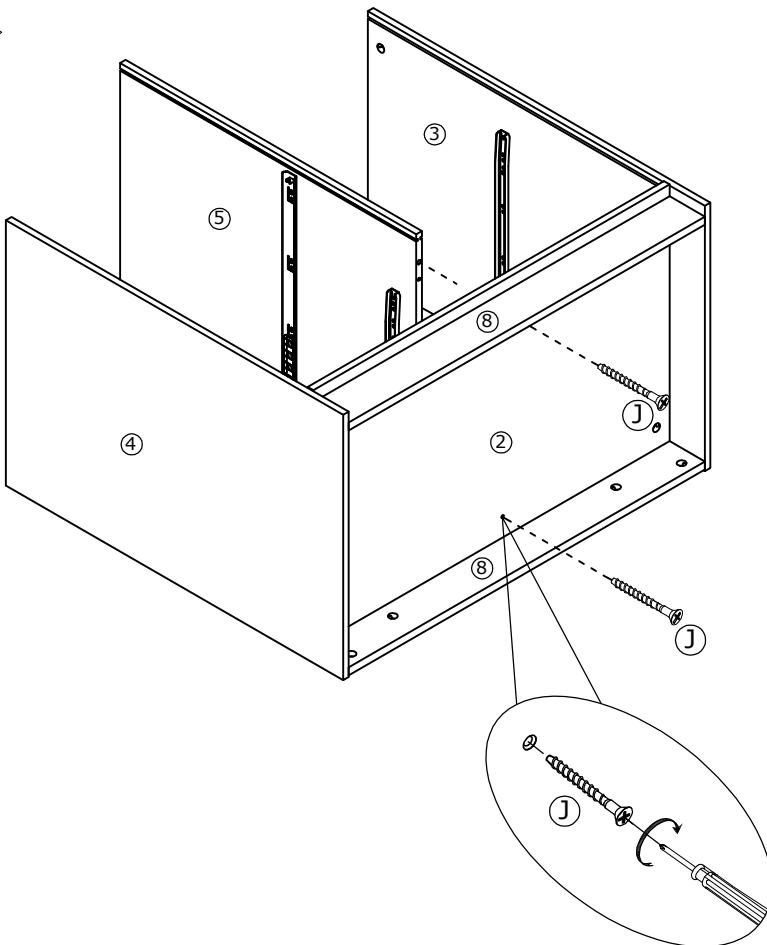

10▷

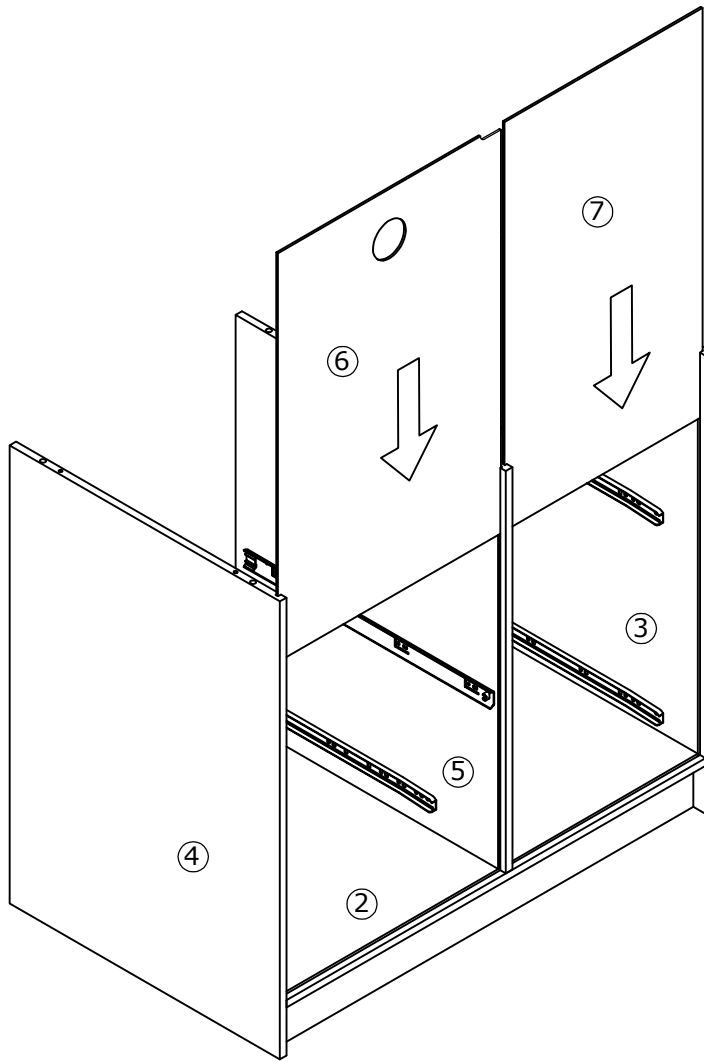

11▷

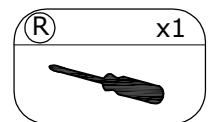
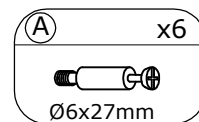
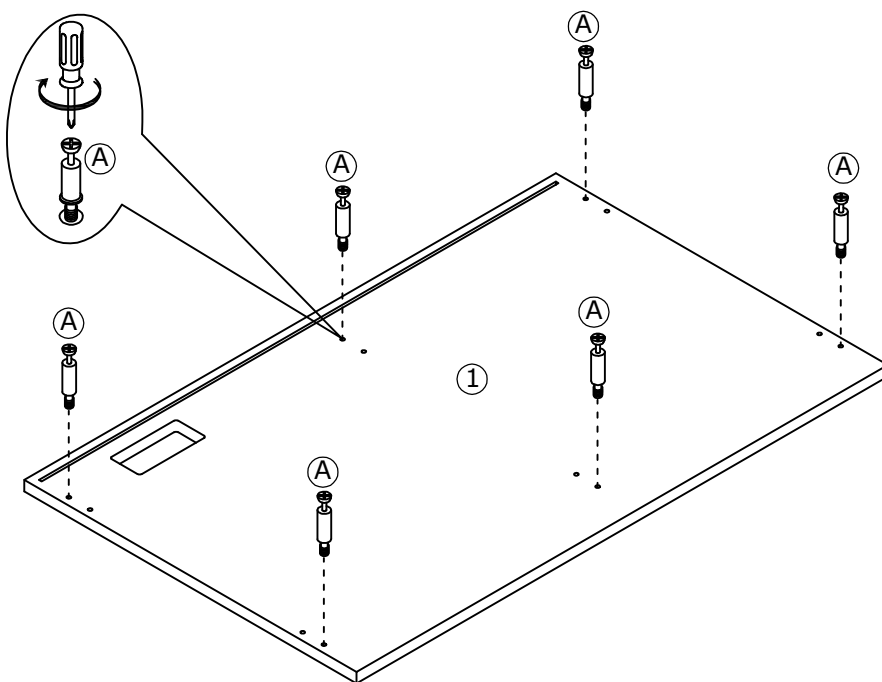

12▷

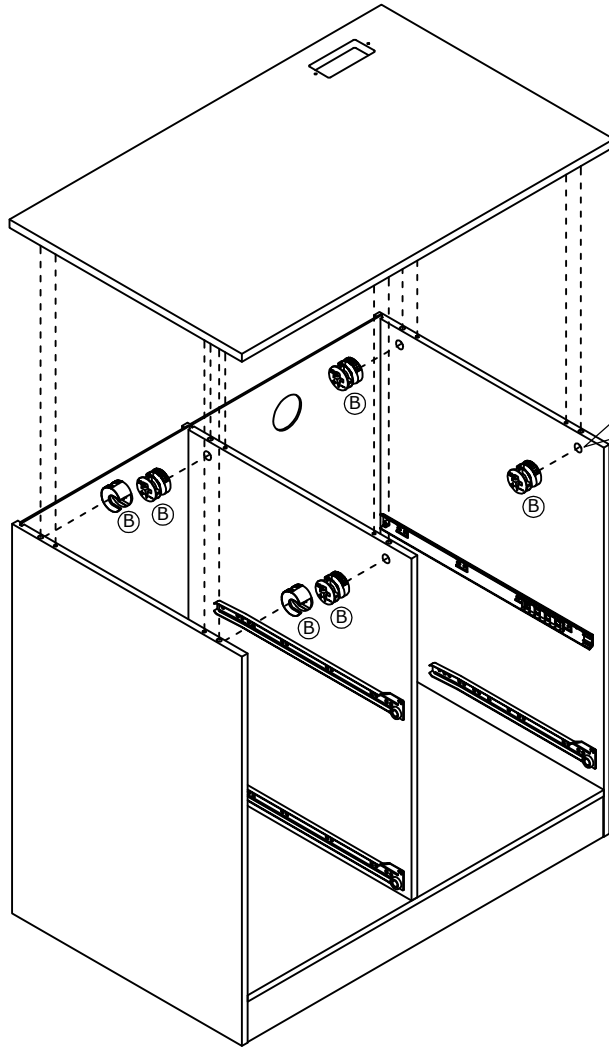

This is how a cam nut works.....

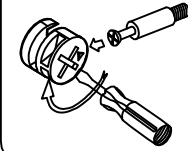

The head of the cam bolt goes into the open mouth of the cam nut. You then turn the cam nut so it tightens over the bolt.

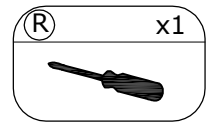
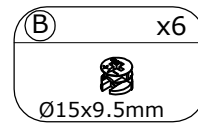

13▷

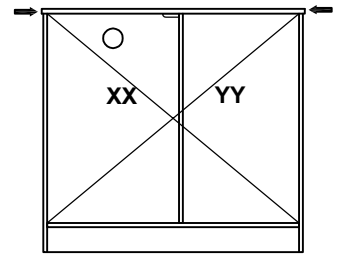
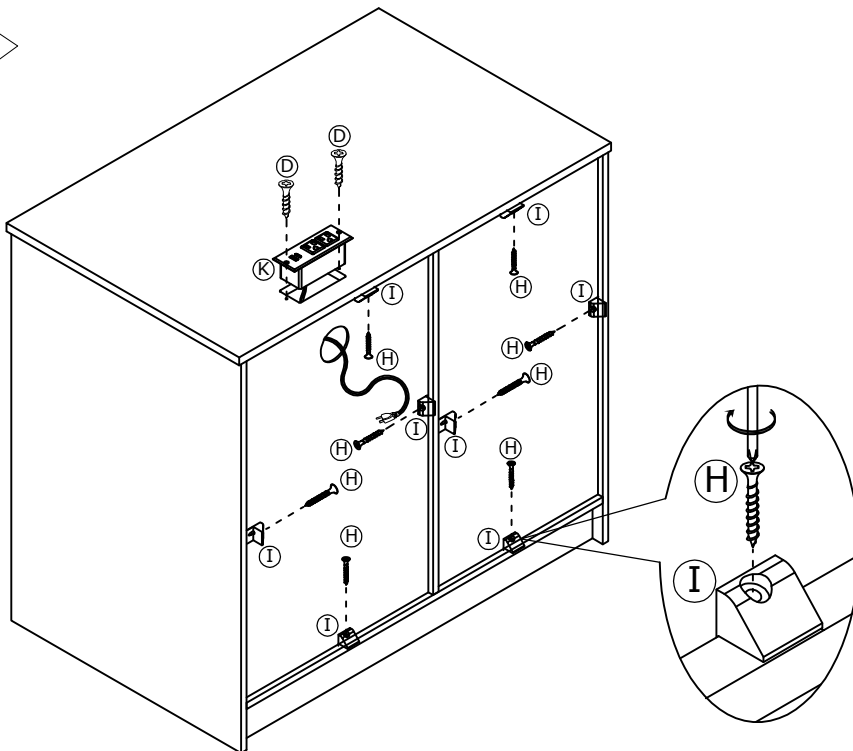

XX = YY

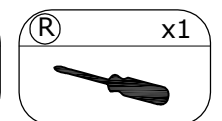
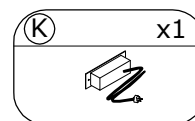
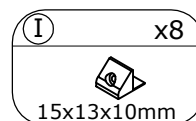
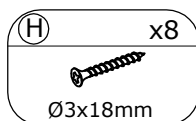
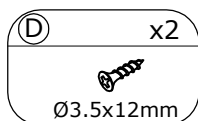

14▷

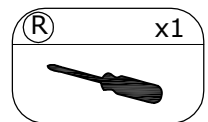
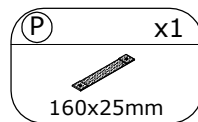
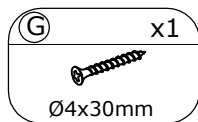
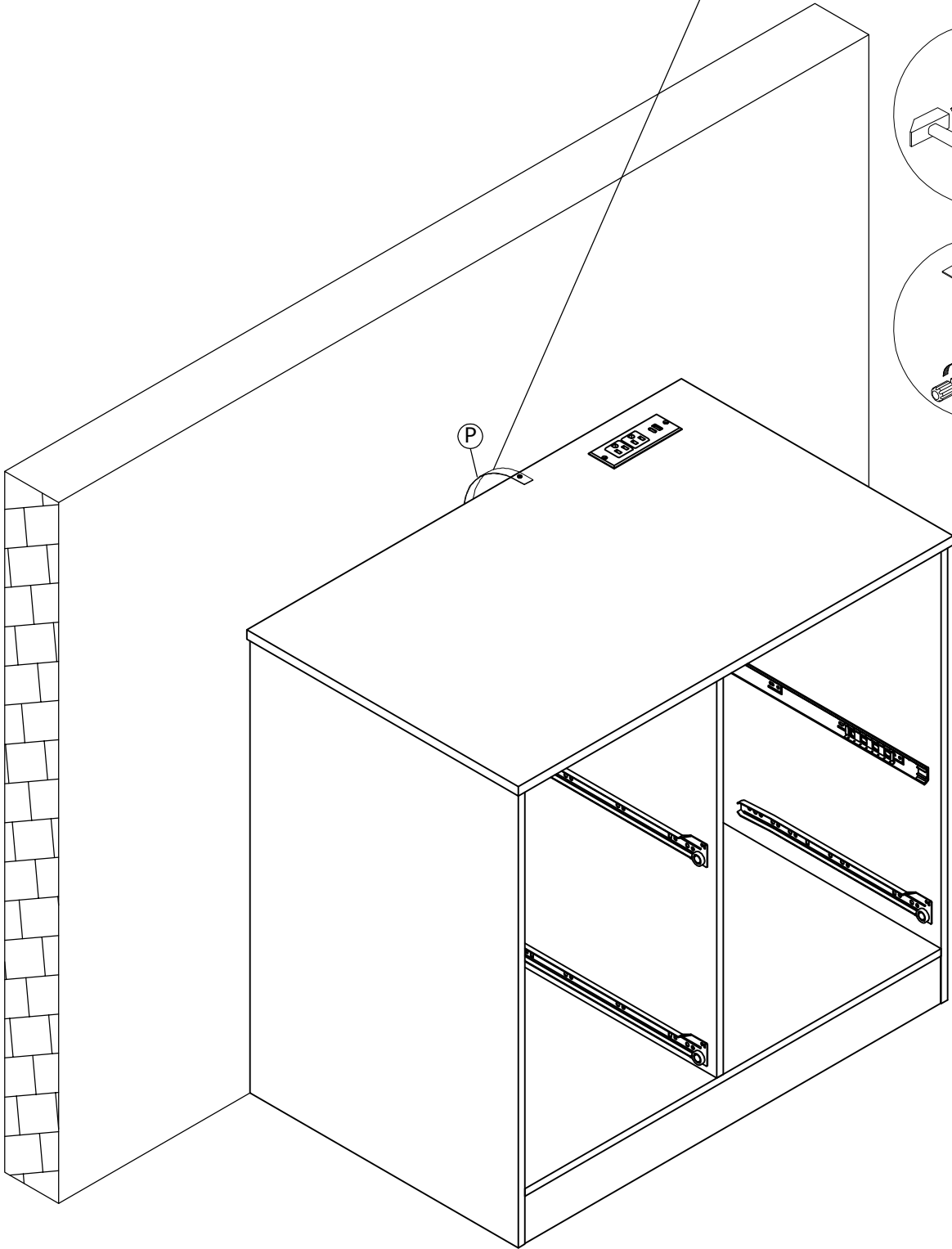
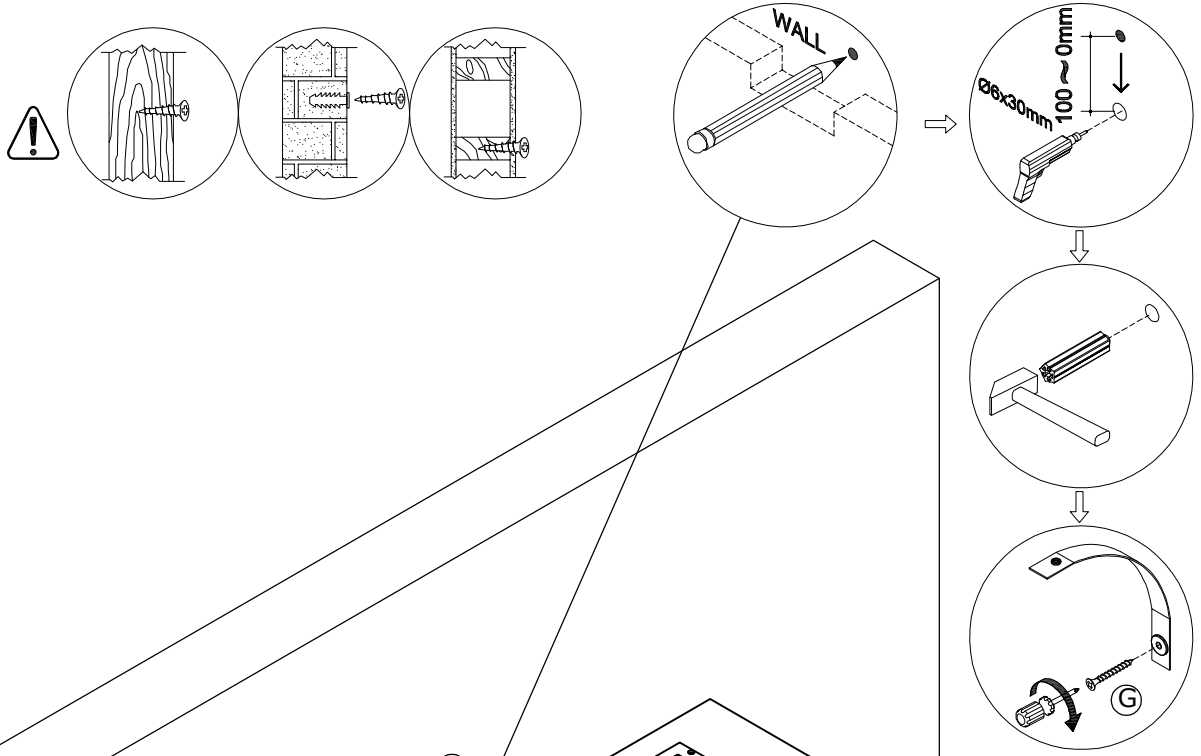

15▷

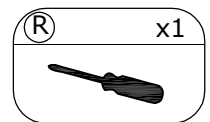
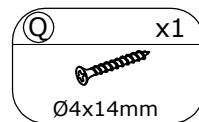
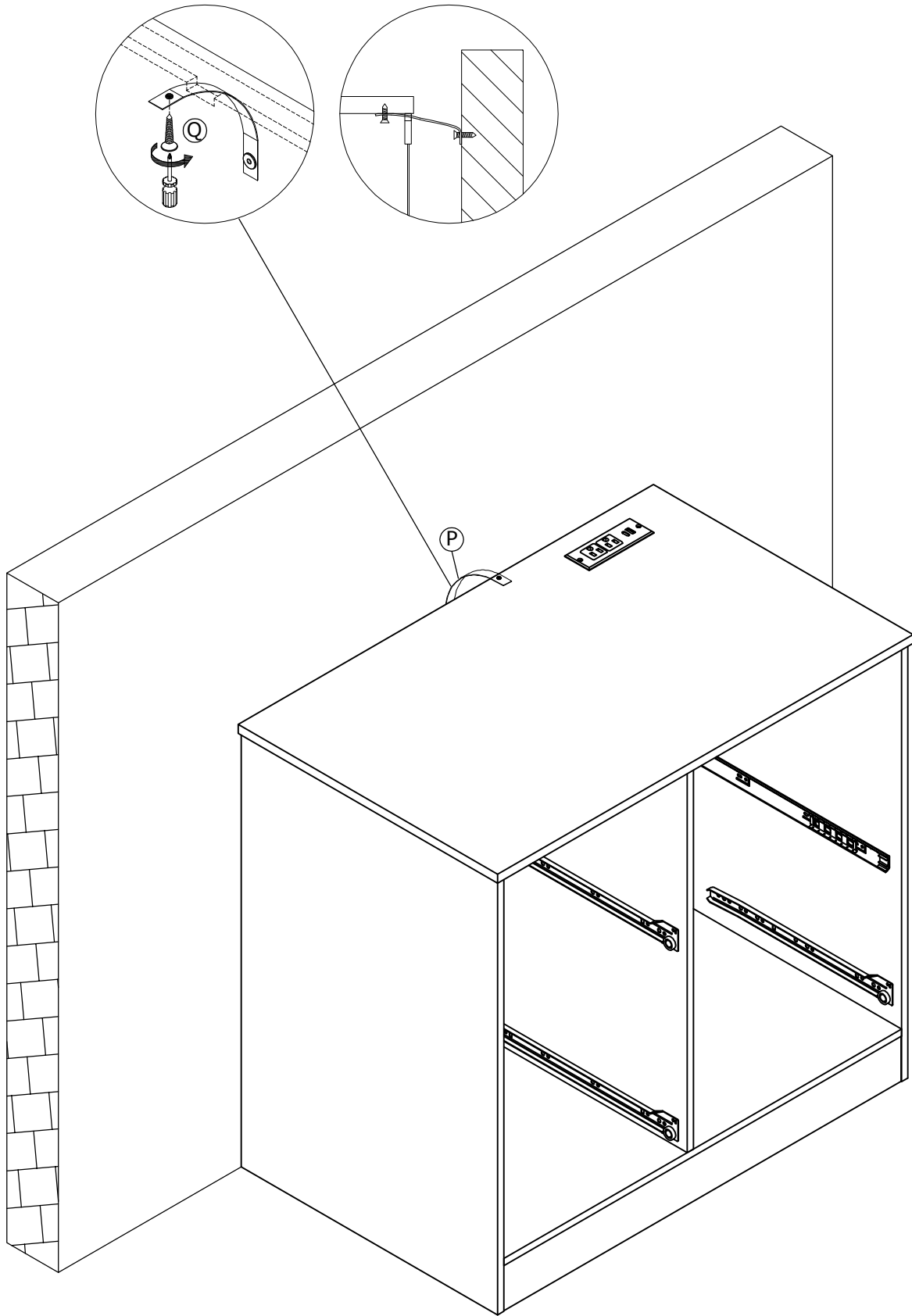

16▷

This is how a cam nut works.....
 The head of the cam bolt goes into the open mouth of the cam nut. You then turn the cam nut so it tightens over the bolt.

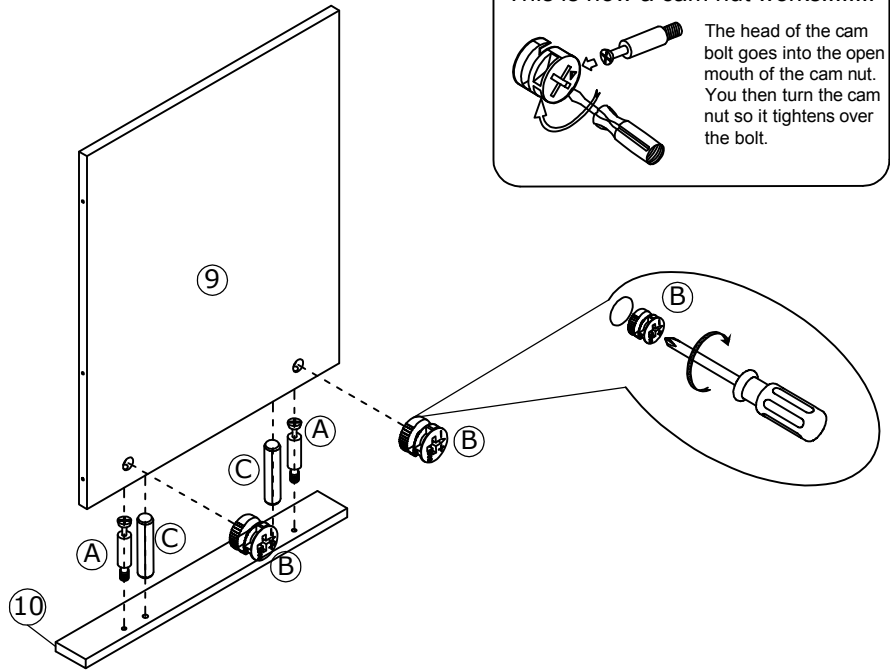

- | | | | |
|-------------------|---------------------|-------------------|--------|
| (A) x2
Ø6x27mm | (B) x2
Ø15x9.5mm | (C) x2
Ø6x30mm | (R) x1 |
|-------------------|---------------------|-------------------|--------|

17▷

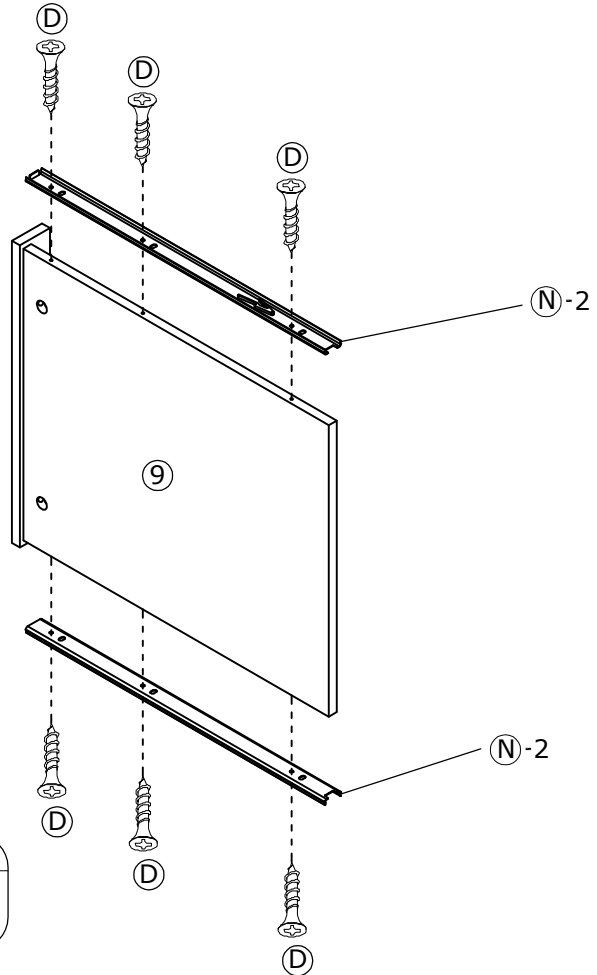
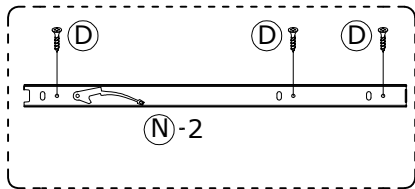

- | | | |
|---------------------|---------------------|--------|
| (D) x6
Ø3.5x12mm | (N-2) x2
L=450mm | (R) x1 |
|---------------------|---------------------|--------|

18▷

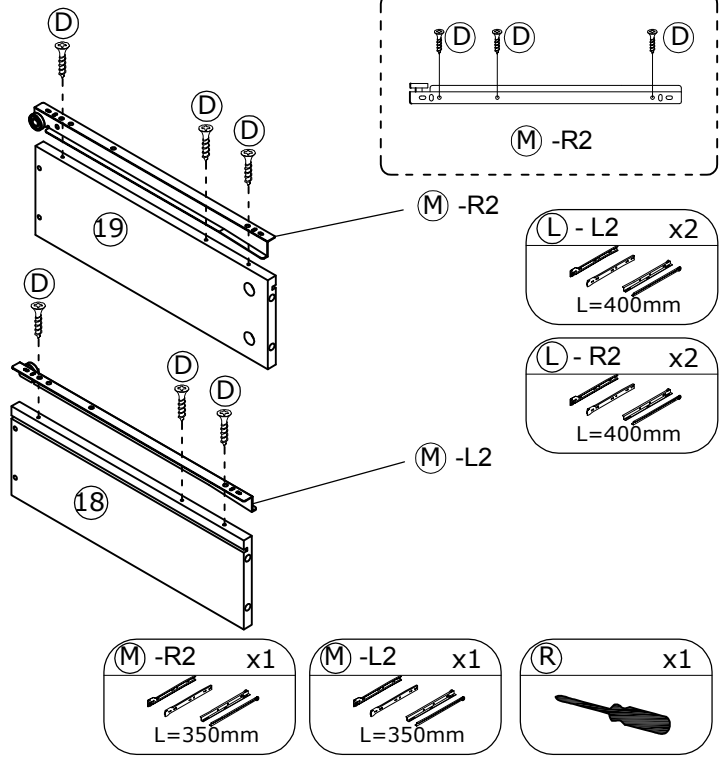
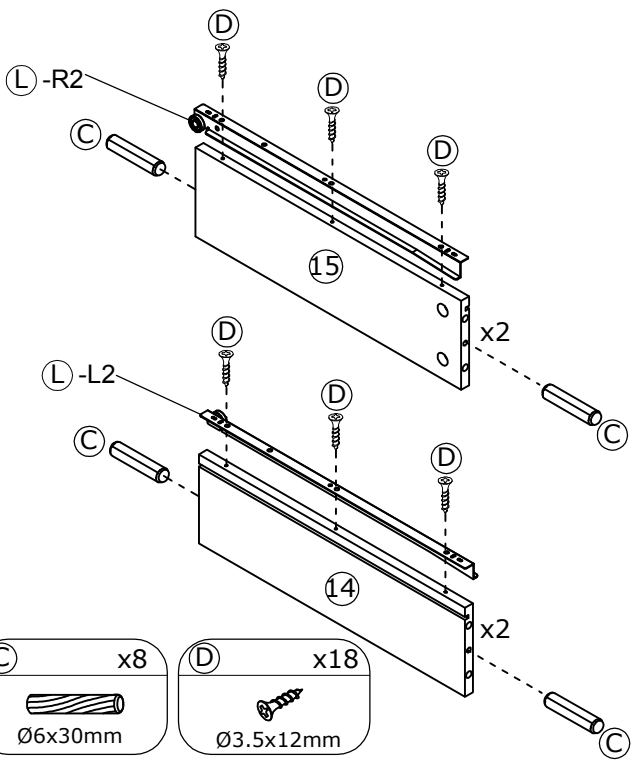
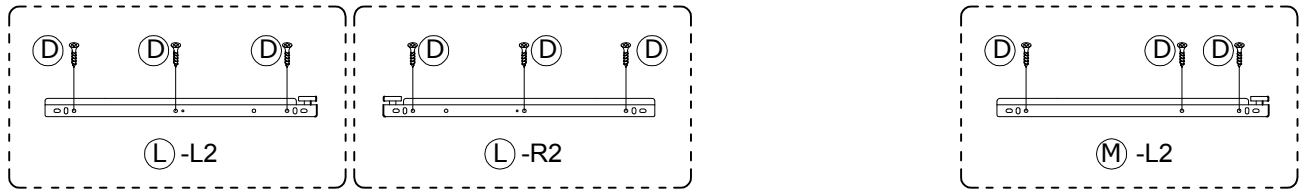

- (C) x8
Ø6x30mm
- (D) x18
Ø3.5x12mm

- (M) -R2 x1
L=350mm
- (M) -L2 x1
L=350mm
- (R) x1

19▷

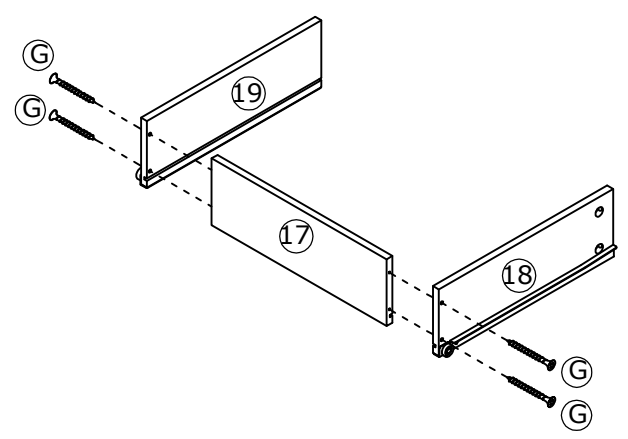
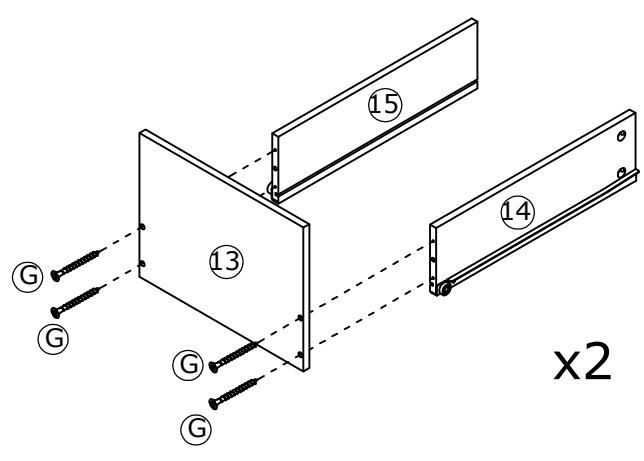

- (G) x12
Ø4x30mm
- (R) x1

20▷

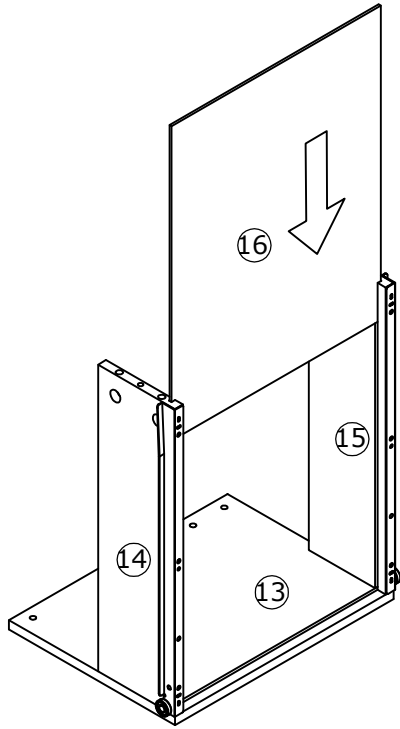

x2

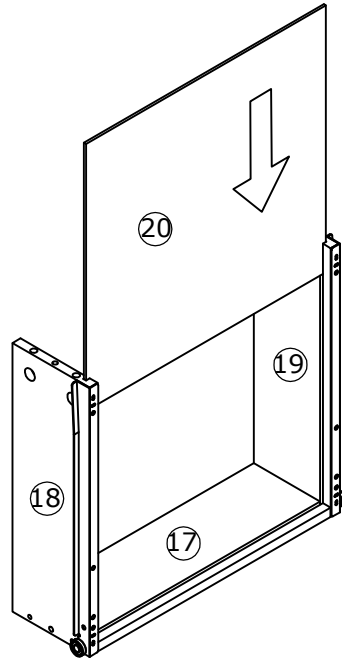

21▷

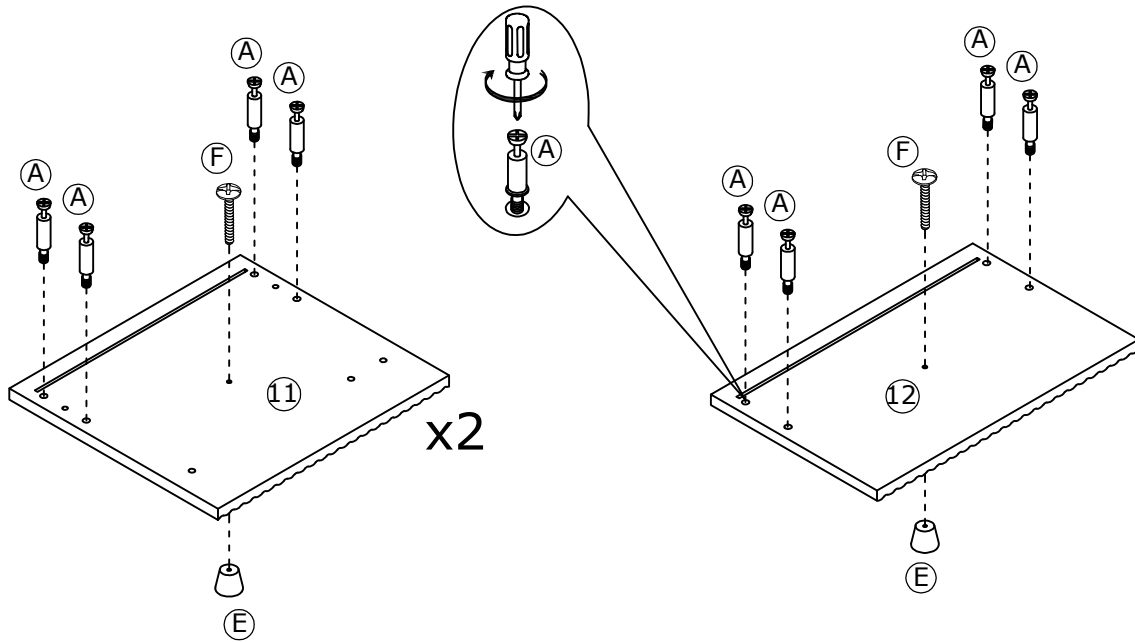

x2

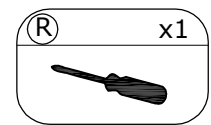
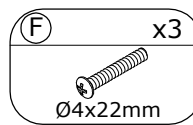
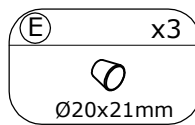
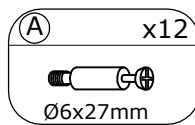

22▷

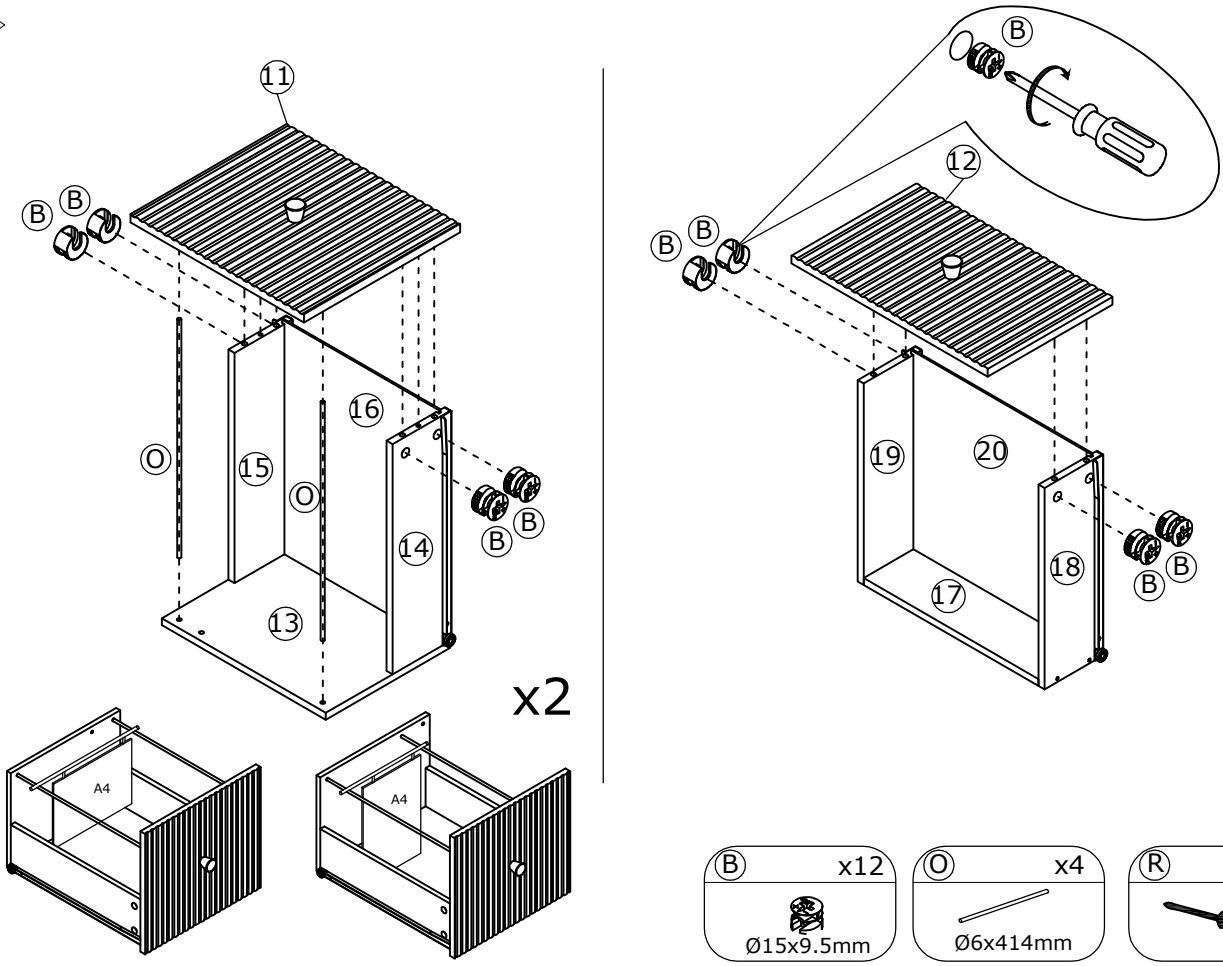

23▷

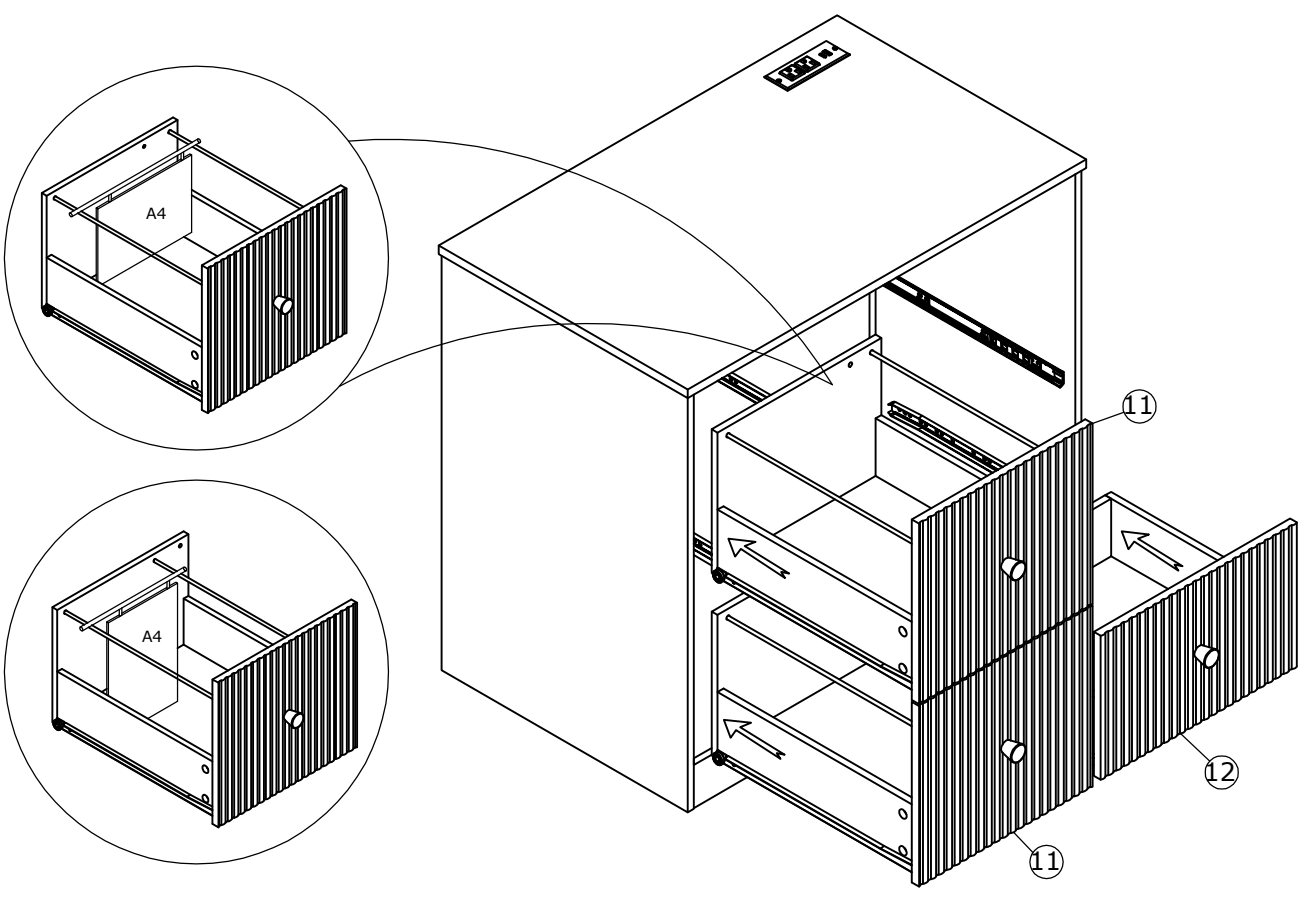

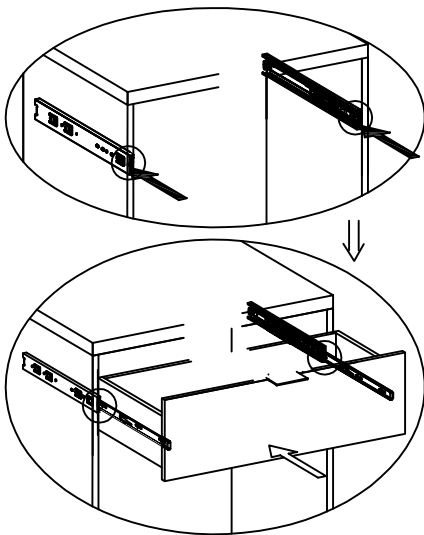
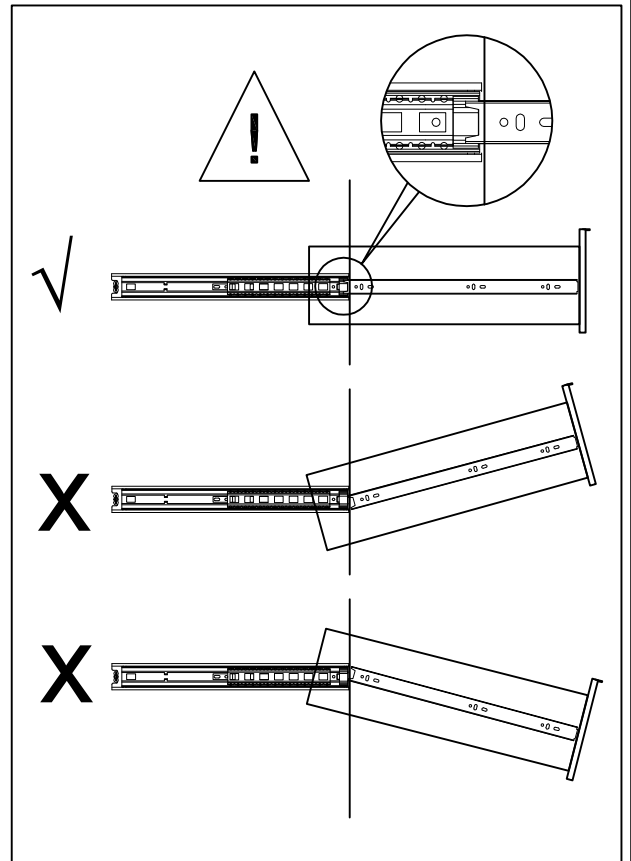
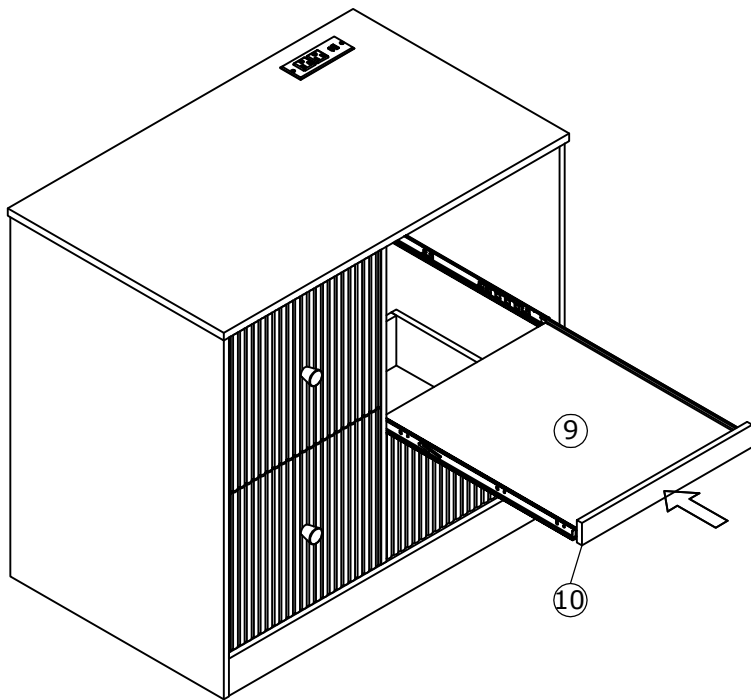

Move inner Ball Bearing track to front of Slide Track (N-1).

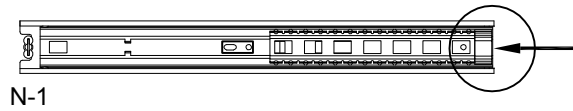

Gently Insert drawer Slide Runner into Ball Bearing Track.

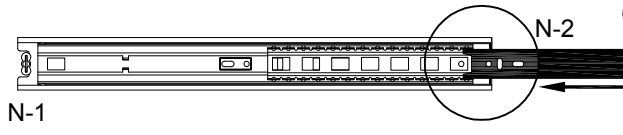

Position Drawer so that Slide Runner (D-2) aligns with Slide Track (D-1) as shown.
Gently push drawer into the closed position.