

IMPORTANT NOTE

Carefully remove all the parts from the carton and put them individually on a soft cloth to prevent scratches or other damages occurring to the wood parts.

We have taken great care in the design of this product and request that you carefully and strictly follow our assembly instructions to ensure a completed product as it was designed.

Part List

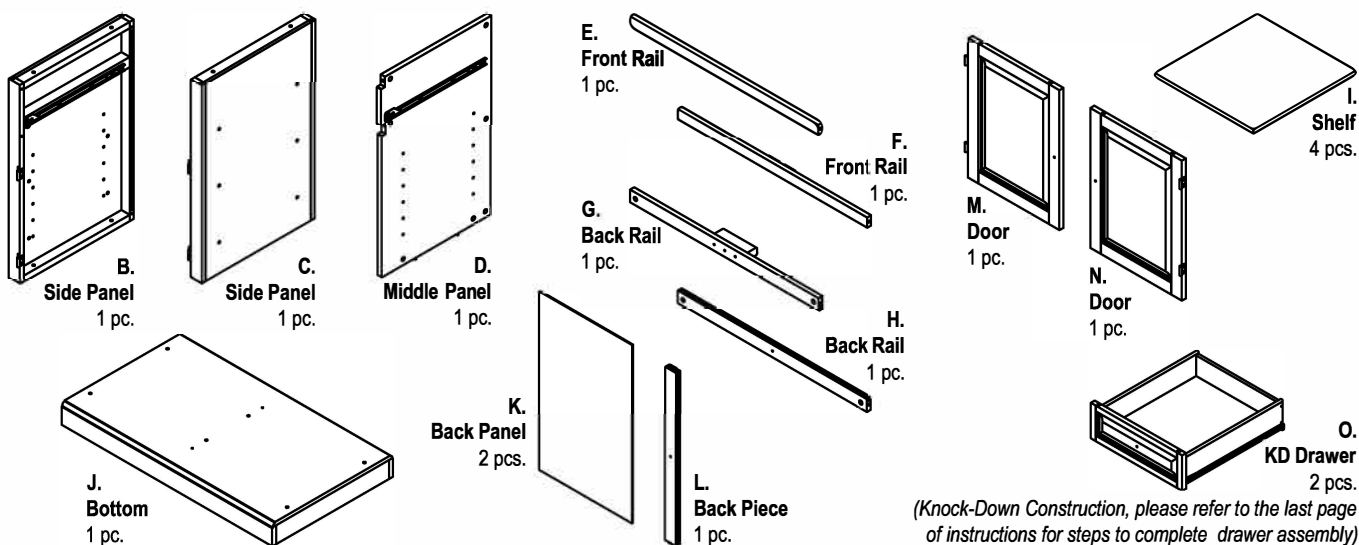

(Knock-Down Construction, please refer to the last page of instructions for steps to complete drawer assembly)

Hardware List

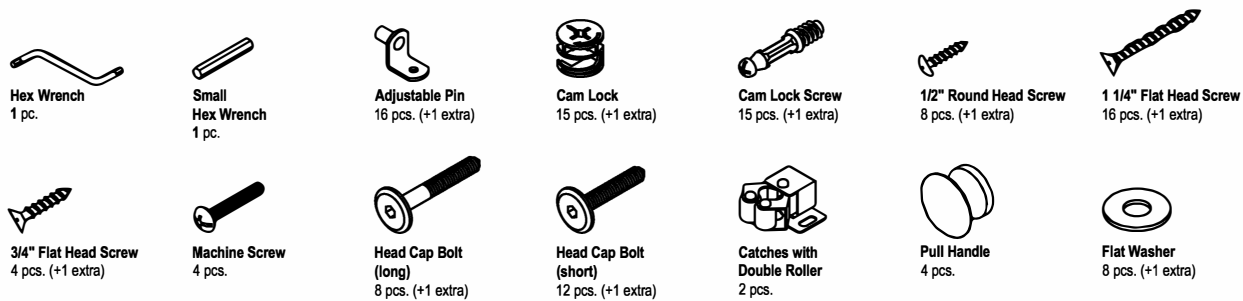

For assembly also need the following:

<p>Monarch Kitchen Island Carton quantity: 1</p>	<p>Monarch Kitchen Island with Oak Top or Monarch Kitchen Island with Granite Top Carton quantity: 1</p>

Tools Required For Assembly : Phillips screwdriver

Assembly Instructions 2/9

IMPORTANT

- * Please keep Hex Wrench in a safe place as you may need to tighten up the Head Cap Bolts in the future.
- * Do not tighten up all the screws until each part is properly assembled.
- * Use a soft cloth between these parts and the floor.

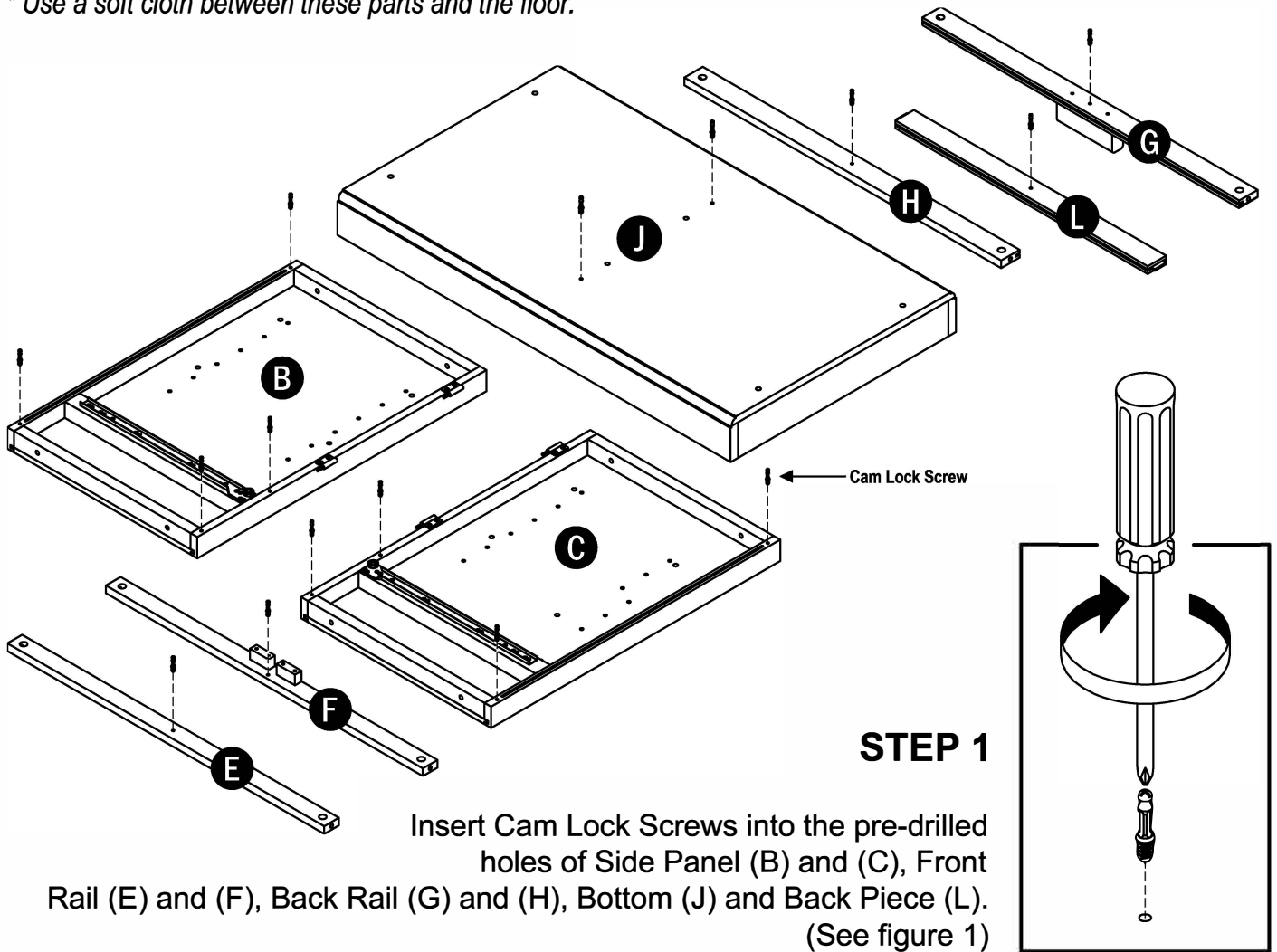
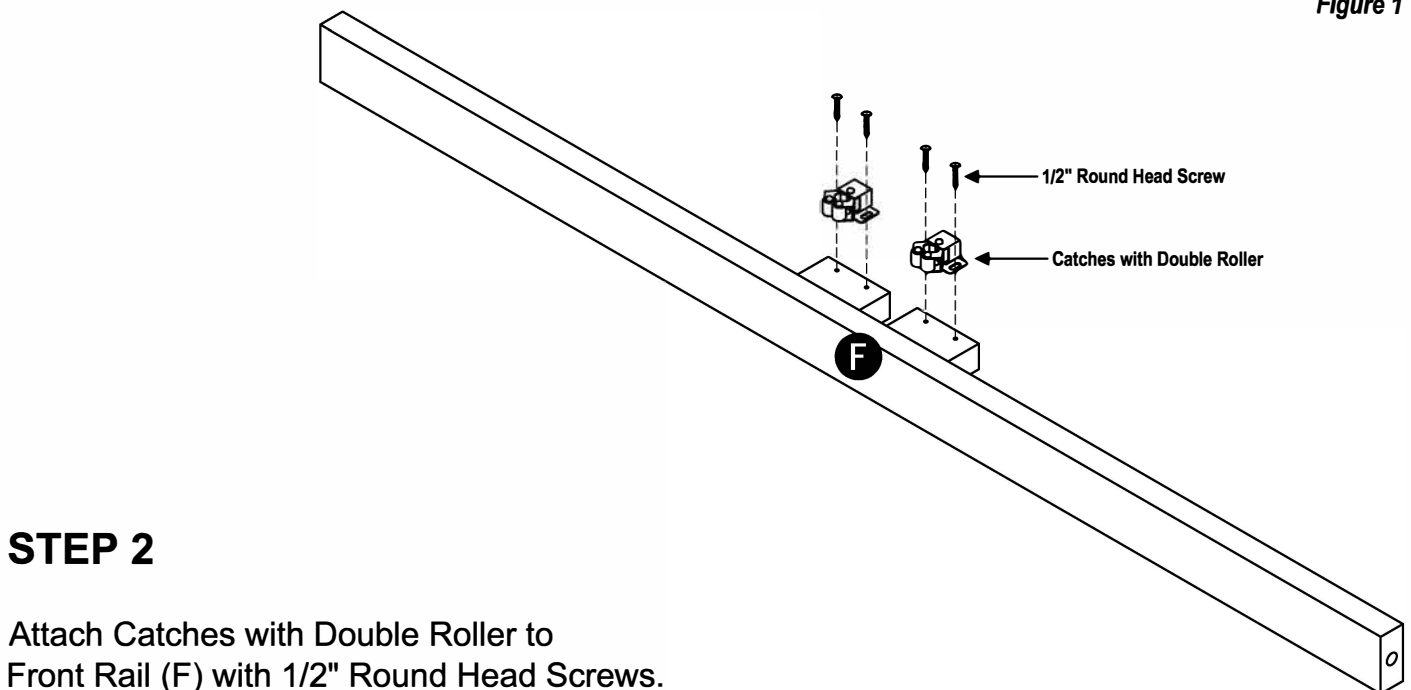

Figure 1



Assembly Instructions 3/9

STEP 3

Slide Back Panel (K) into the groove of Back Rail (G) and (H) and Back Piece (L).

Attach Middle Panel (D) to Front Rail (E) and (F), Back Rail (G) and (H) and Back Piece (L) using Cam Locks. (See figure 2)

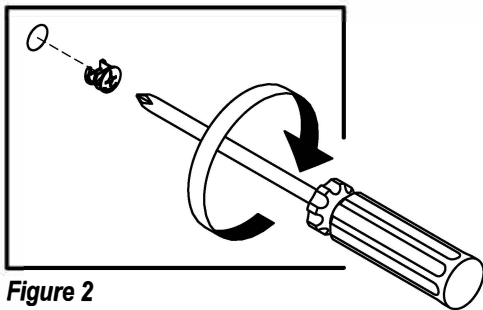
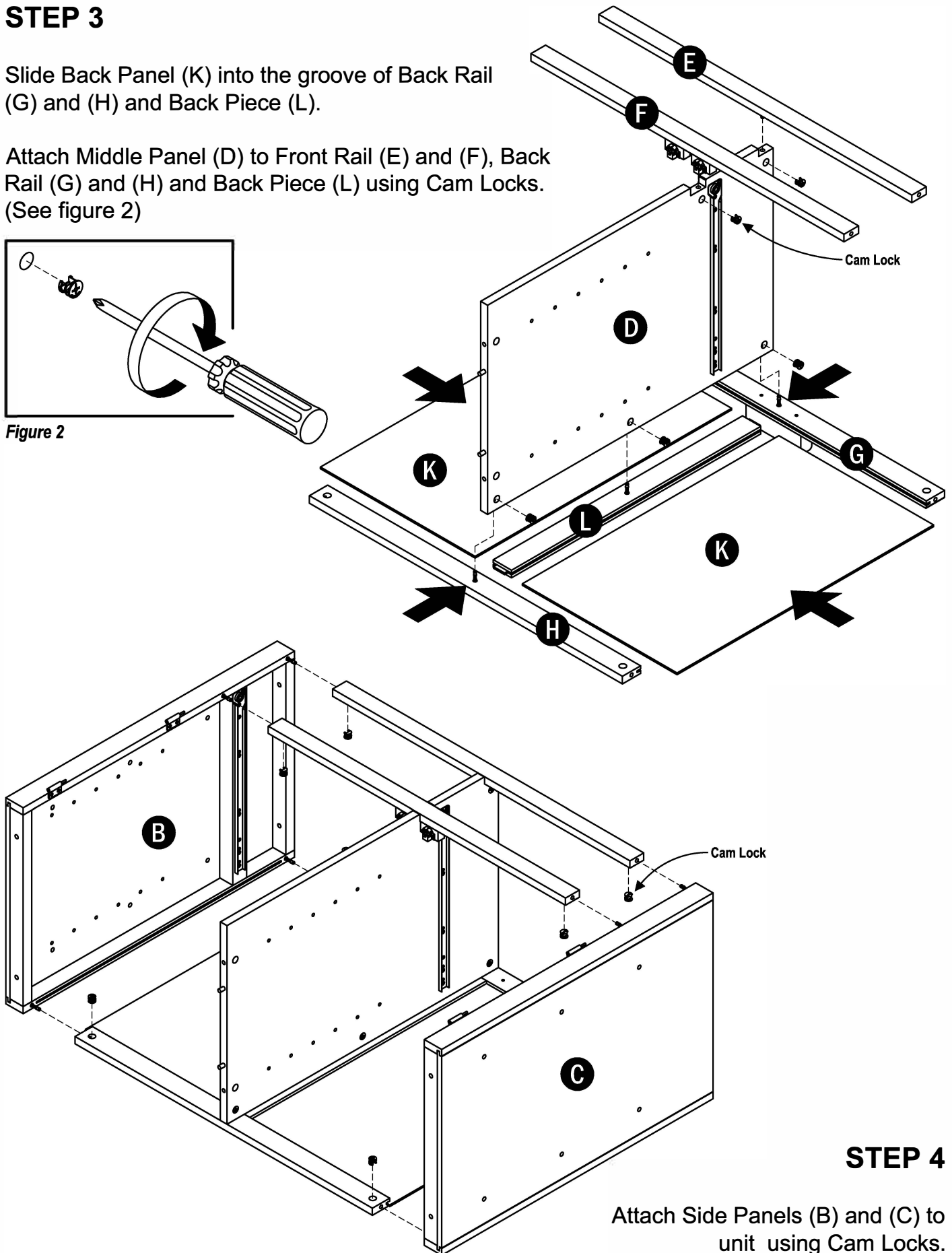

Figure 2



STEP 4

Attach Side Panels (B) and (C) to unit using Cam Locks.

Assembly Instructions 4/9

STEP 5

Attach Bottom (J) to unit using Cam Locks, Head Cap Bolts (long) and Washers.

Tighten bolts using Hex Wrench.
(See figure 3)

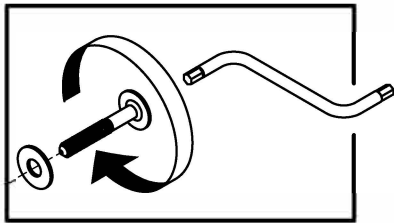
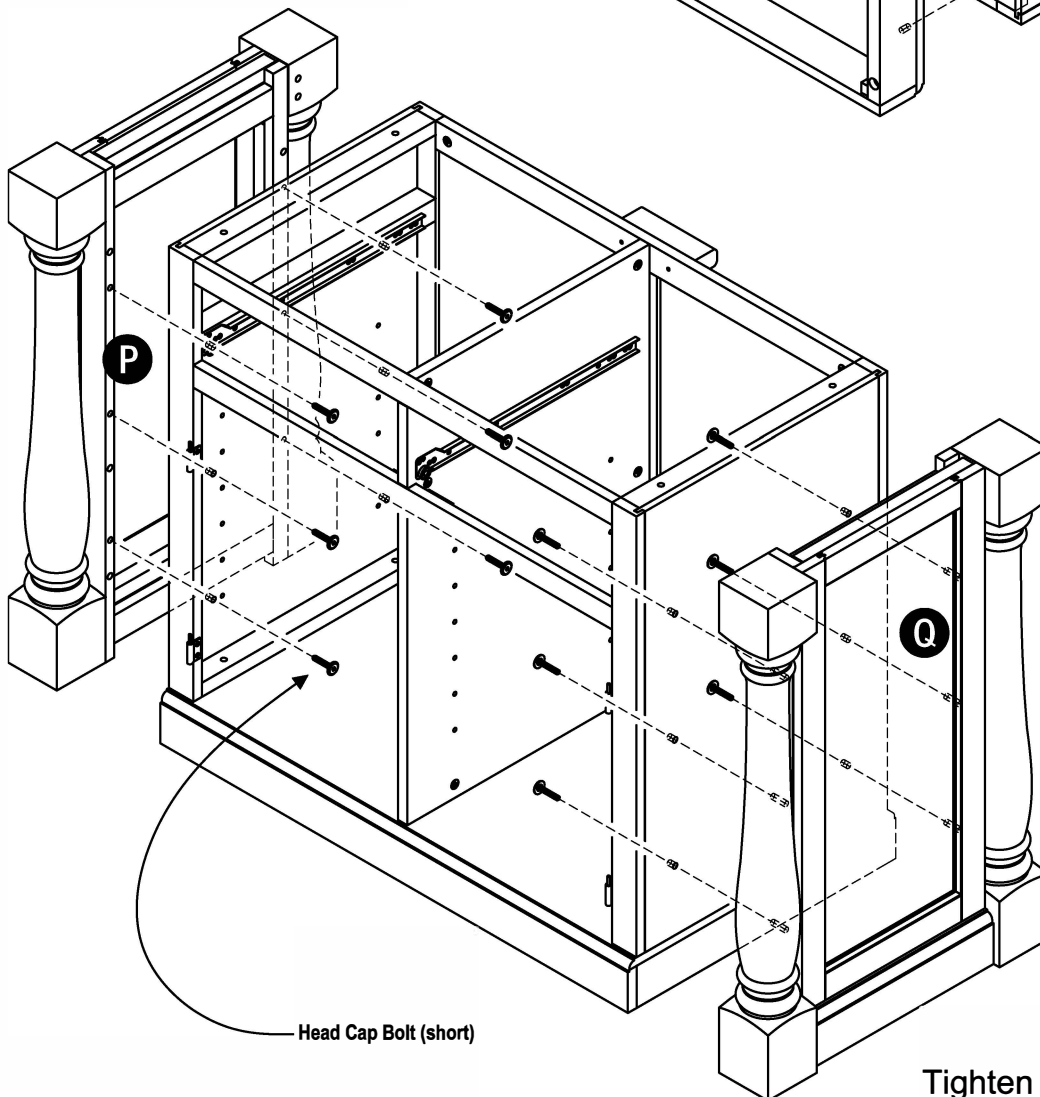
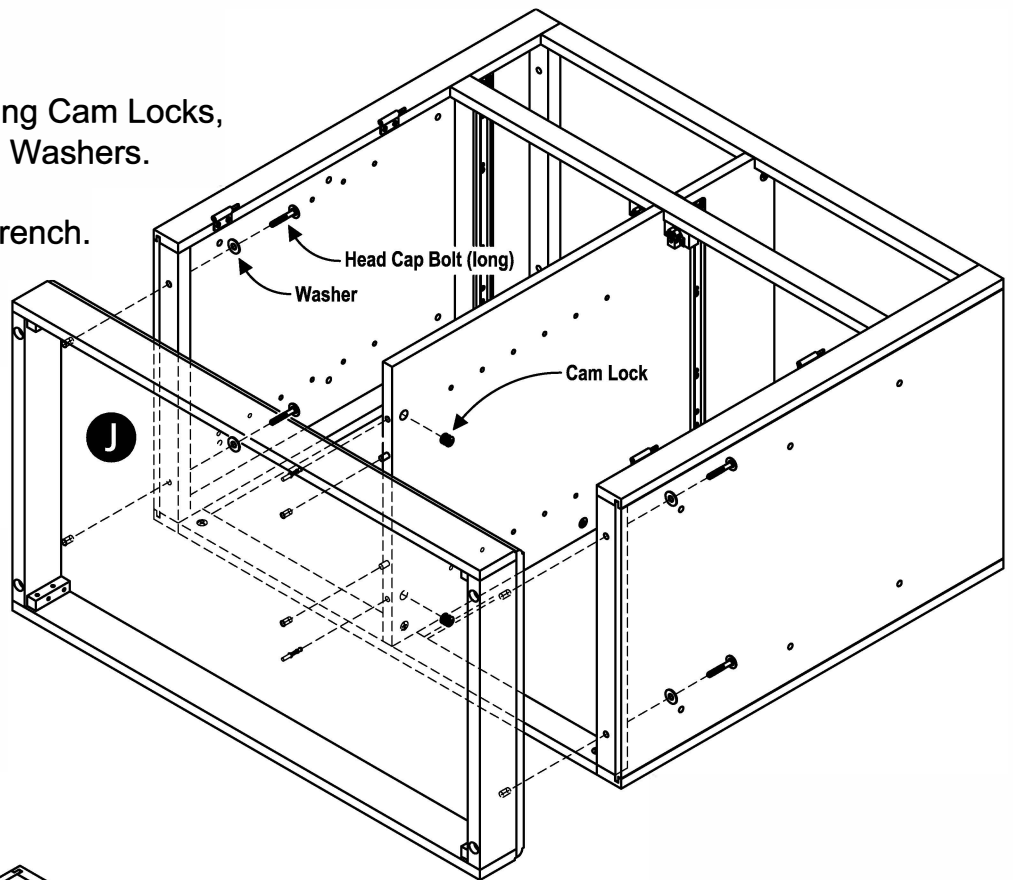

Figure 3



STEP 6

Attach Frame Leg (P) and (Q) to unit using Head Cap Bolts (short).

Tighten bolts using Hex Wrench.

STEP 7

Attach Doors (M) and (N) to the side panels, by sliding the door lift hinges into the side panel lift hinges.
(see Figure 4)

Assemble Pull Handles to Door (M) and (N) with Machine Screws.
(see Figure 5)

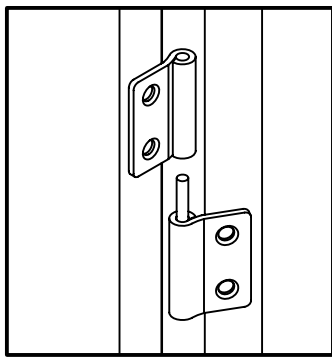
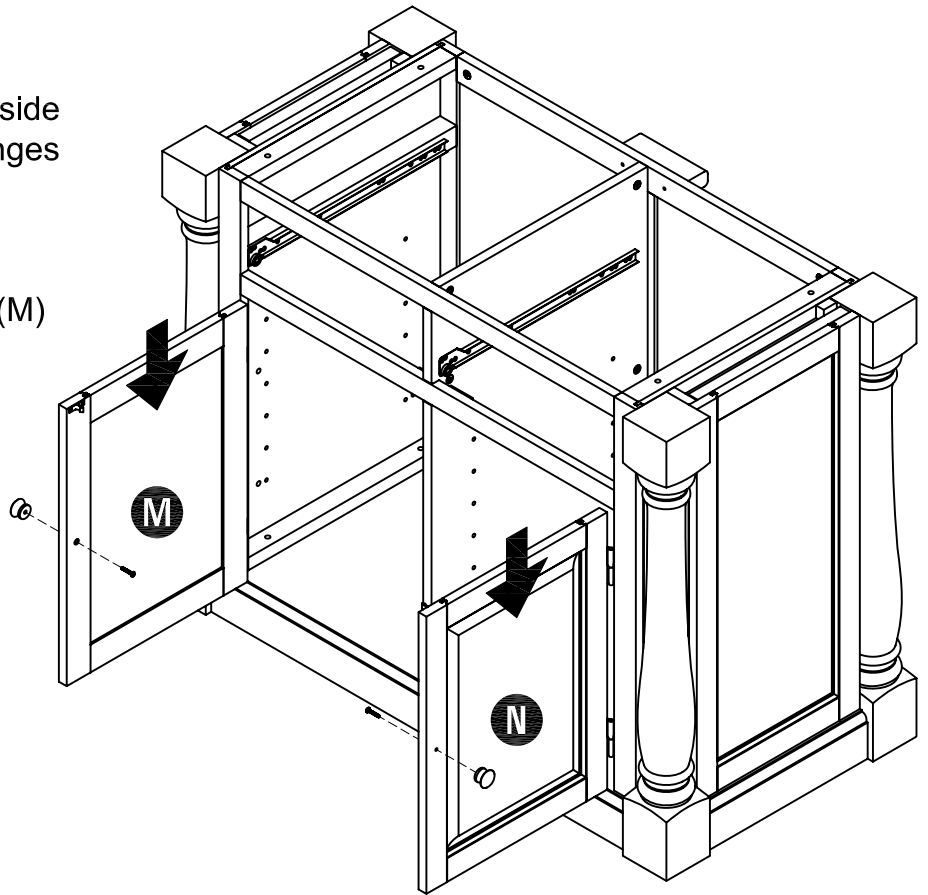

Figure 4

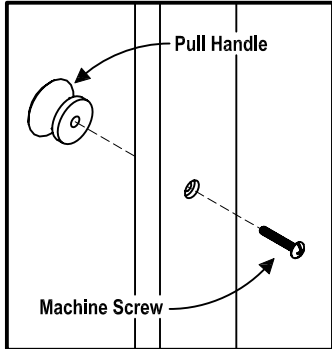

Figure 5

STEP 8

Slide Drawers (O) into place.

Insert Adjustable Pins into side panels and middle panel at the desired level.

Slide Shelves (I) into position.

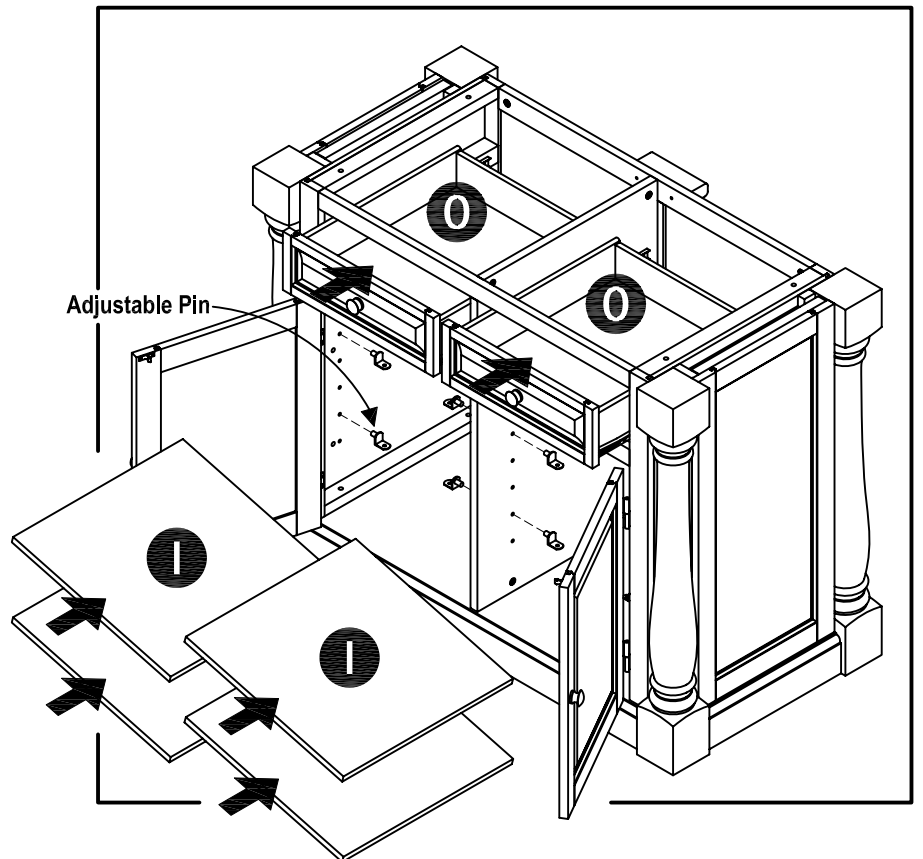

Assembly Instructions 6/9

STEP 9

Pull out the Drawers from unit.

Place Top (A) onto the unit, using Head Cam Bolts (long) and Washers.

Tighten bolts using Hex Wrench. (see Figure 6)

Slide Drawers into place.

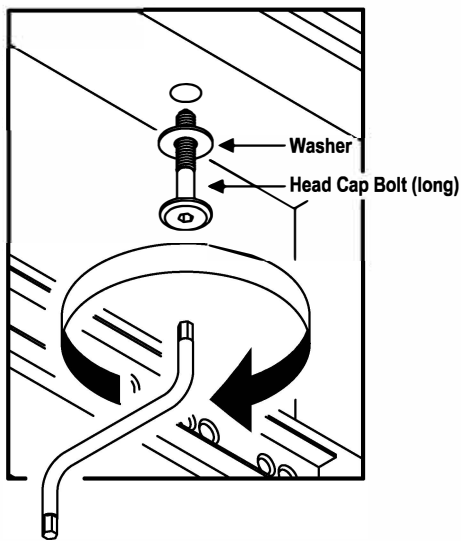
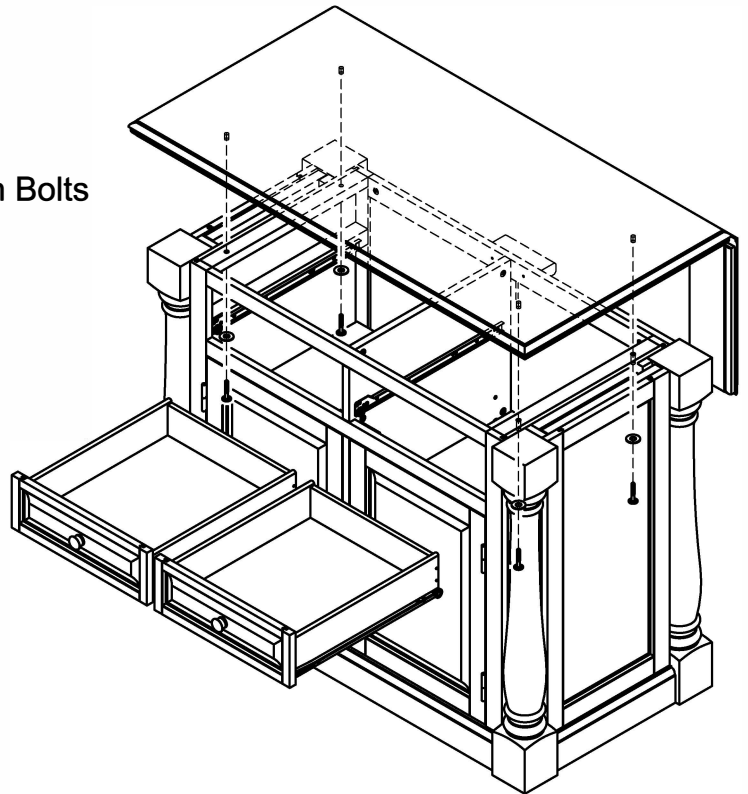
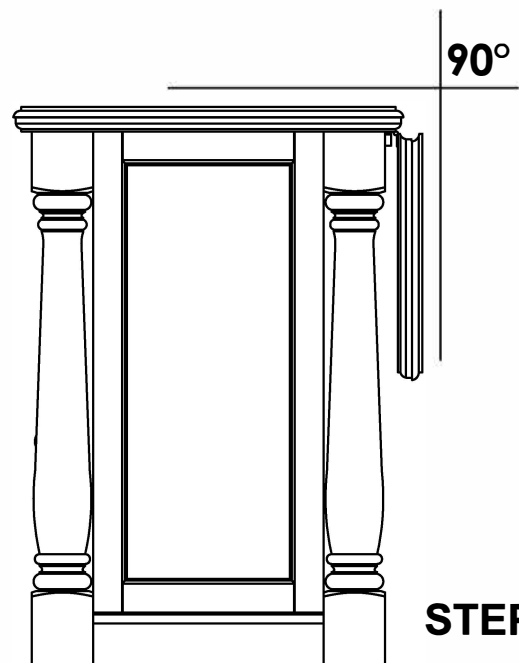
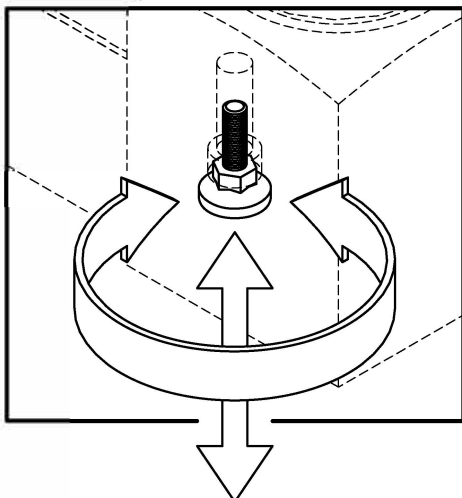

Figure 6

STEP 11

To level the unit, adjust the adjustable levelers on the bottom.



STEP 10

When Leaf Top is down, it should be oriented vertically.

If it is not vertical and adjustment is desired, loosen the Head Cap Bolts (short) which attach Top (A) to the unit.

Slide Top (A) slightly forward or backward until the Leaf Top is oriented vertically.

Re-tighten the Head Cap Bolts. (See Figure 7)

TOP EXTENSION INSTRUCTIONS

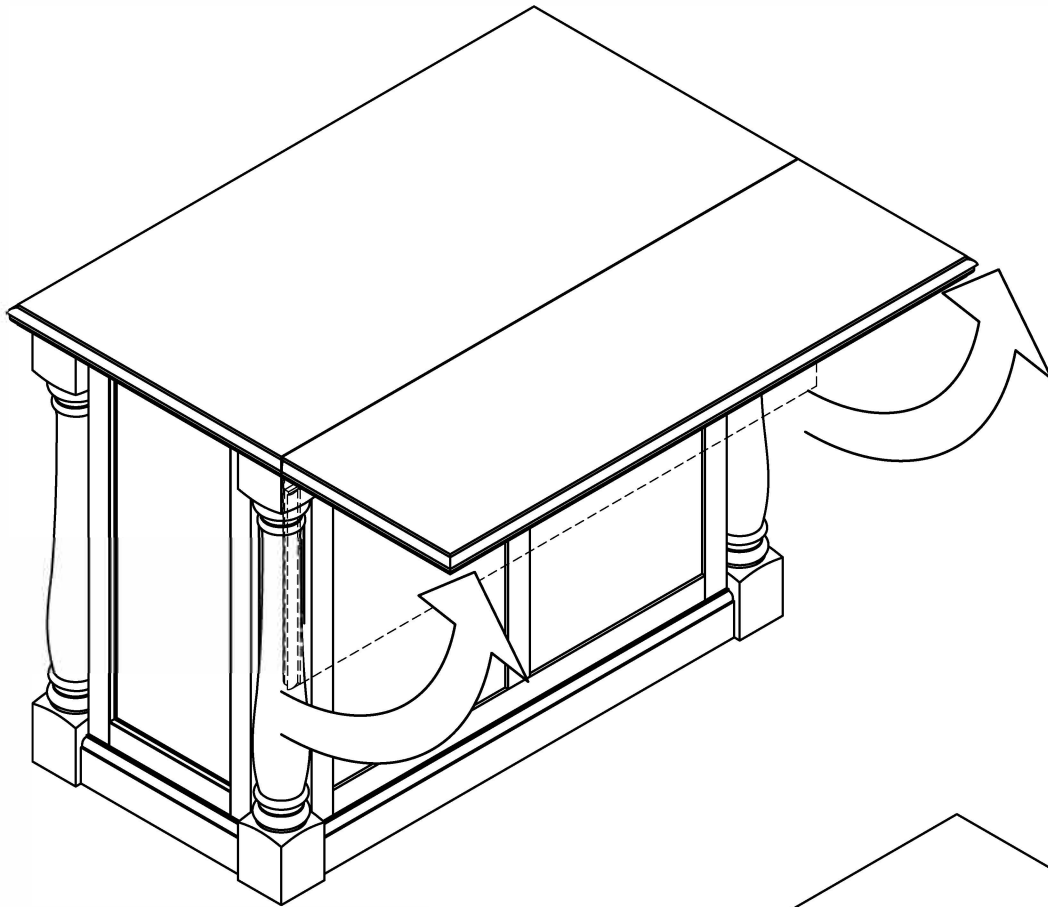

STEP 1

Lift up the Leaf Top.

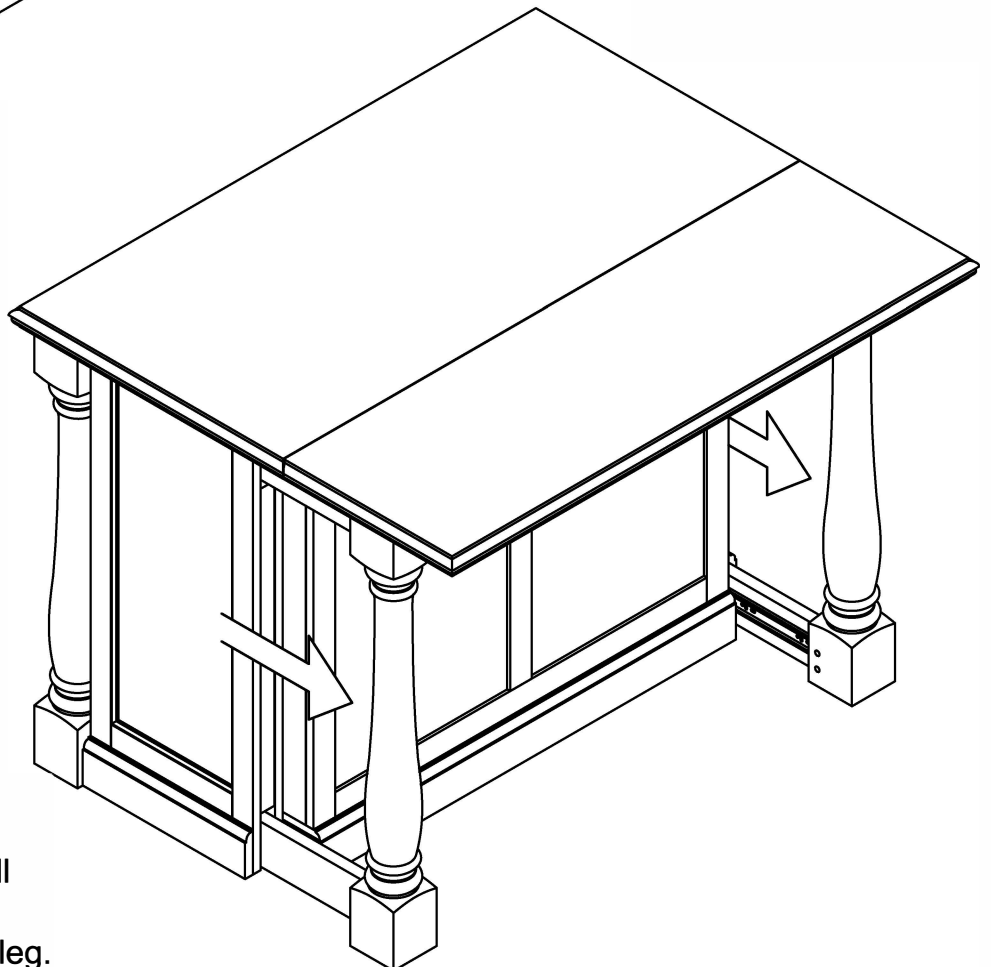

STEP 2

Holding the Leaf Top up, pull out a back leg from the unit; then pull out the other back leg.

Drawer (O)

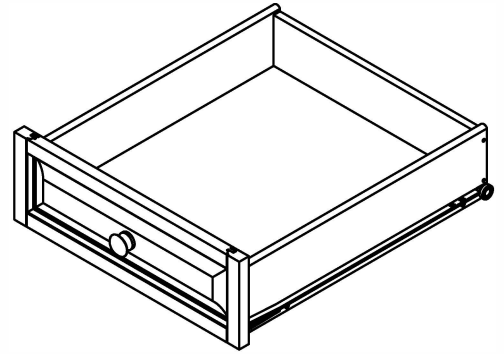

STEP 1

Attach Side Part (O3) to Front Part (O1) and Back Part (O2) using a Phillips screwdriver and 1 1/4" Flat Head Screws.

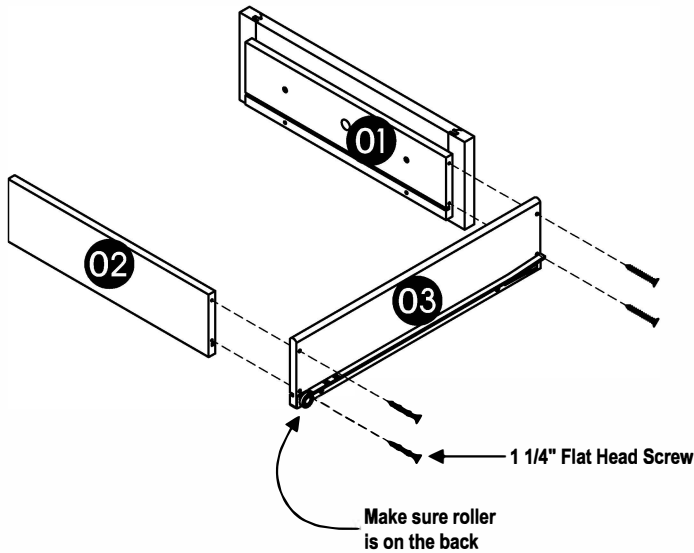

STEP 2

Insert Base Part (O5) into the groove.

Attach Side Part (O4) to Front Part (O1) and Back Part (O2) using a Phillips screwdriver and 1 1/4" Flat Head Screws.

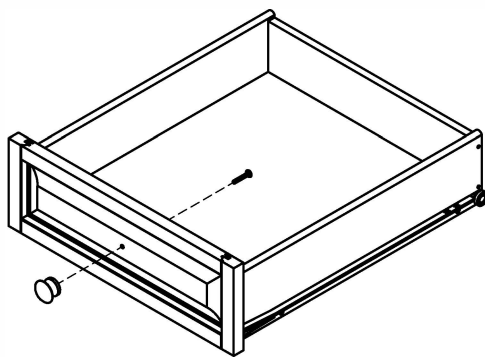
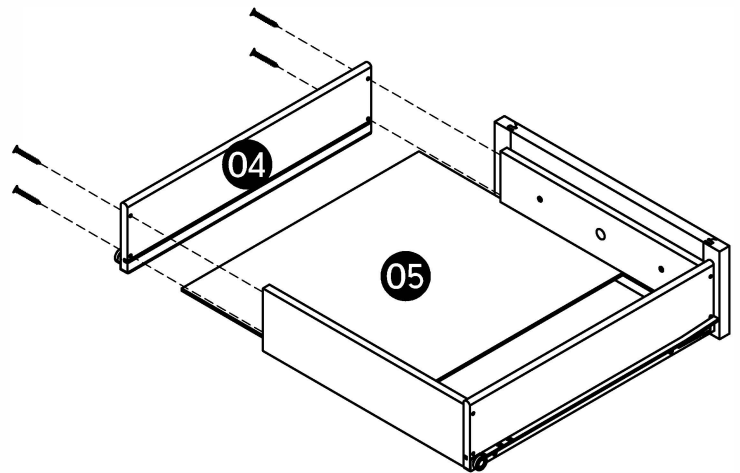

STEP 3

Attach Pull Handles with Machine Screws.

Part List

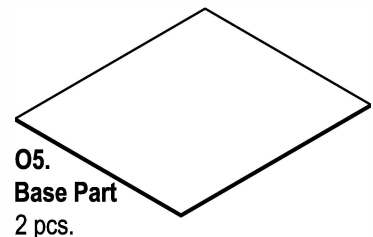
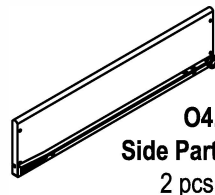
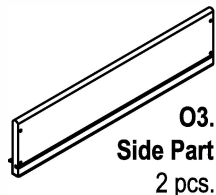
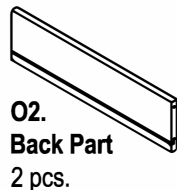
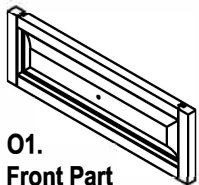

Assembly Instructions 9/9

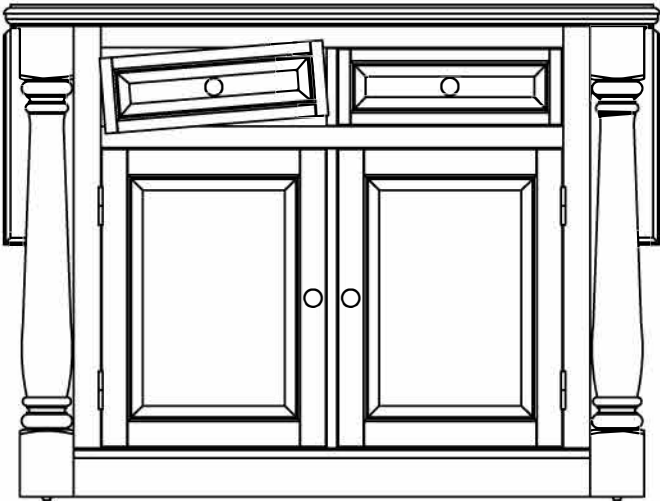

I. IF A DRAWER DOES NOT ALIGN

STEP 1

Loosen slightly the upper screws.

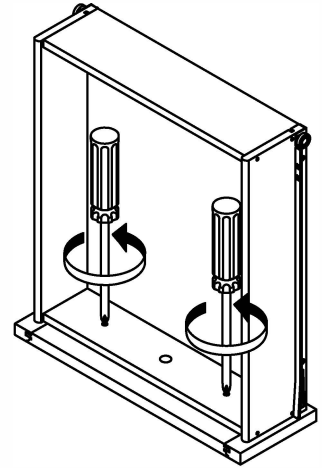

STEP 2

Insert the drawer into the main body, then adjust the drawer front panel left or right and up or down, until the drawer gaps look proportional.

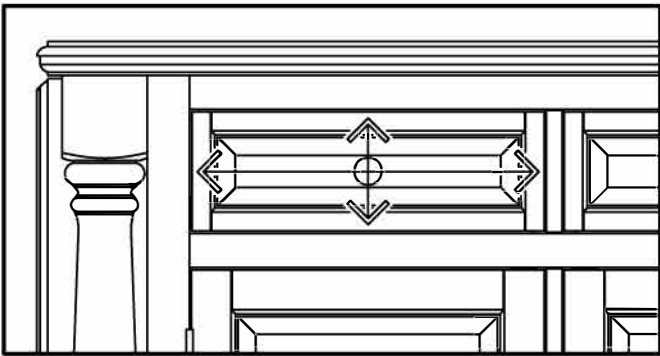

II. IF A DRAWER ALREADY ALIGNS

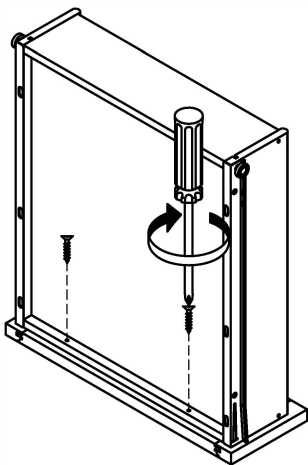

Pull out drawer slowly. Lock the drawer front panel into position with 3/4" Flat Head Screws.

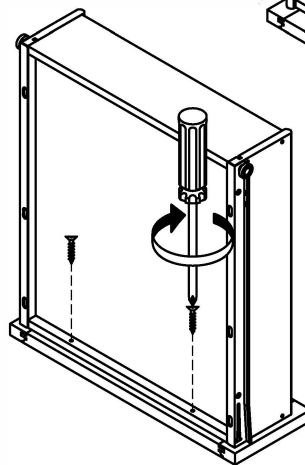
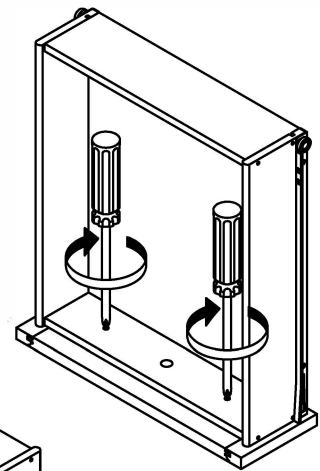

STEP 3

Pull the drawer open slowly and tighten the upper screws. Make sure the front panel does not move and lock the drawer front panel into position with 3/4" Flat Head Screws.

VERY IMPORTANT !!

CARE INSTRUCTIONS

NEVER

USE GLASS CLEANERS ON FINISHED FURNITURE. AMMONIA WILL CHEMICALLY ATTACK THE LACQUER.

NEVER

ALLOW LIQUIDS OF ANY KIND TO REMAIN ON THE FURNITURE. ABSORPTION CAUSES WOOD TO WARP AND SPLIT AND FINISHES TO DELAMINATE.

DO NOT WRITE DIRECTLY ON SURFACE.



PREVENT MARKING

DO NOT PLACE IN DIRECT SUNLIGHT.



PREVENT FADING

DO NOT USE COMMERCIAL WAXES AND POLISHES.



PREVENT YELLOWING

DO NOT PLACE HOT OBJECTS ON SURFACE.



PREVENT FINISH DAMAGE

DO NOT USE RUBBER BASED PLACE MATS.



PREVENT DISCOLORING

TO CLEAN

USE A SOFT CLOTH MOISTENED IN LEMON OIL POLISH OR LUKEWARM SOAP AND WATER, THEN BUFF WITH A DRY CLEAN CLOTH.

