

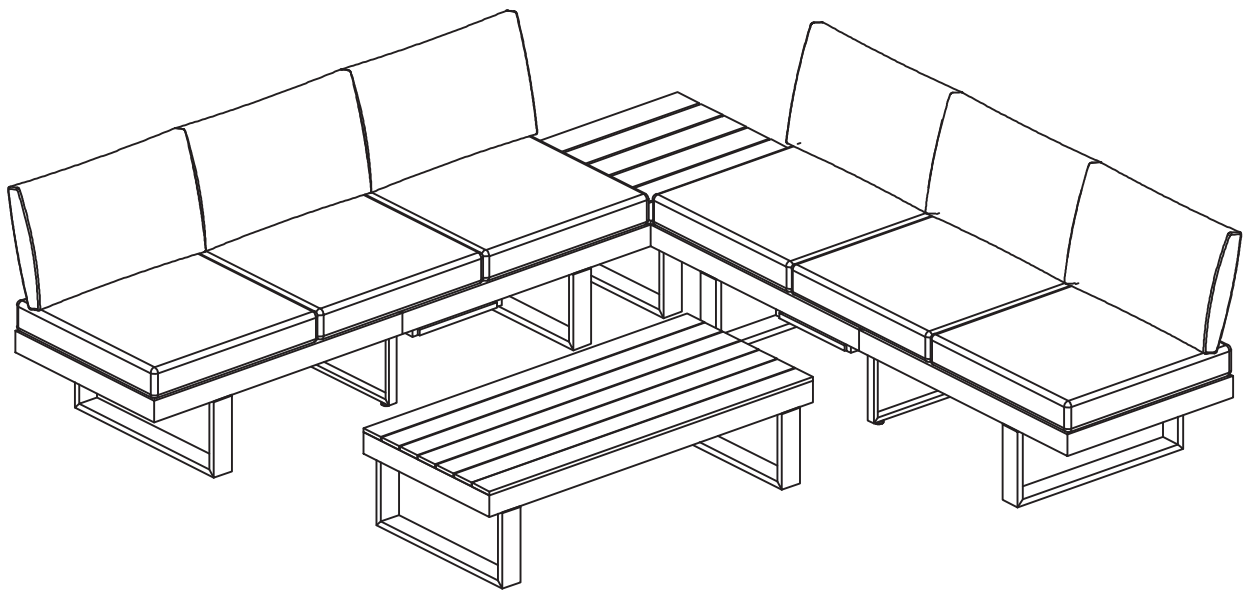















ASSEMBLY INSTRUCTION









ITEM NO.: N719P246893-N719P246894-N719P246895











N719P246893 -COMPONENT LIST

NO.	DRAWING	QTY	DESCRIPTION
A		1	Large coffee table frame
B		2	.Big coffee table feet
C		1	Small coffee table frame
D		2	Small coffee table leg
L		2	Tergum
M		2	Seat cushion
N		2	Back cushion
O		48	Hex socket screw M6*20mm
P		8	Hex socket screw M6*35mm
Q		4	Hex socket screw M6*50mm
R		12	Hex socket screw M6*85mm
S		84	Gasket
T		16	Lock nut
U		1	Allen key
V		1	Outer hexagonal wrench

N719P246894 -COMPONENT LIST

NO.	DRAWING	QTY	DESCRIPTION
D		2	Sofa feet
E		1	Sofa seat
F		1	Sofa seat
I		2	Slide rail
J		1	Pull the side table.
K		1	Middle leg
L		2	Tergum
M		2	Seat cushion
N		2	Back cushion

N719P246895 -COMPONENT LIST

NO.	DRAWING	QTY	DESCRIPTION Sofa f
D		2	Sofa feet
G		1	Sofa seat
H		1	Sofa seat
I		2	Slide rail
J		1	Pull the side table
K		1	Middle leg
L		2	Tergum
M		2	Seat cushion
N		2	Back cushion

* Take out the A , B , C , D , L , M , N , O , P , Q , R , S , T , U , V

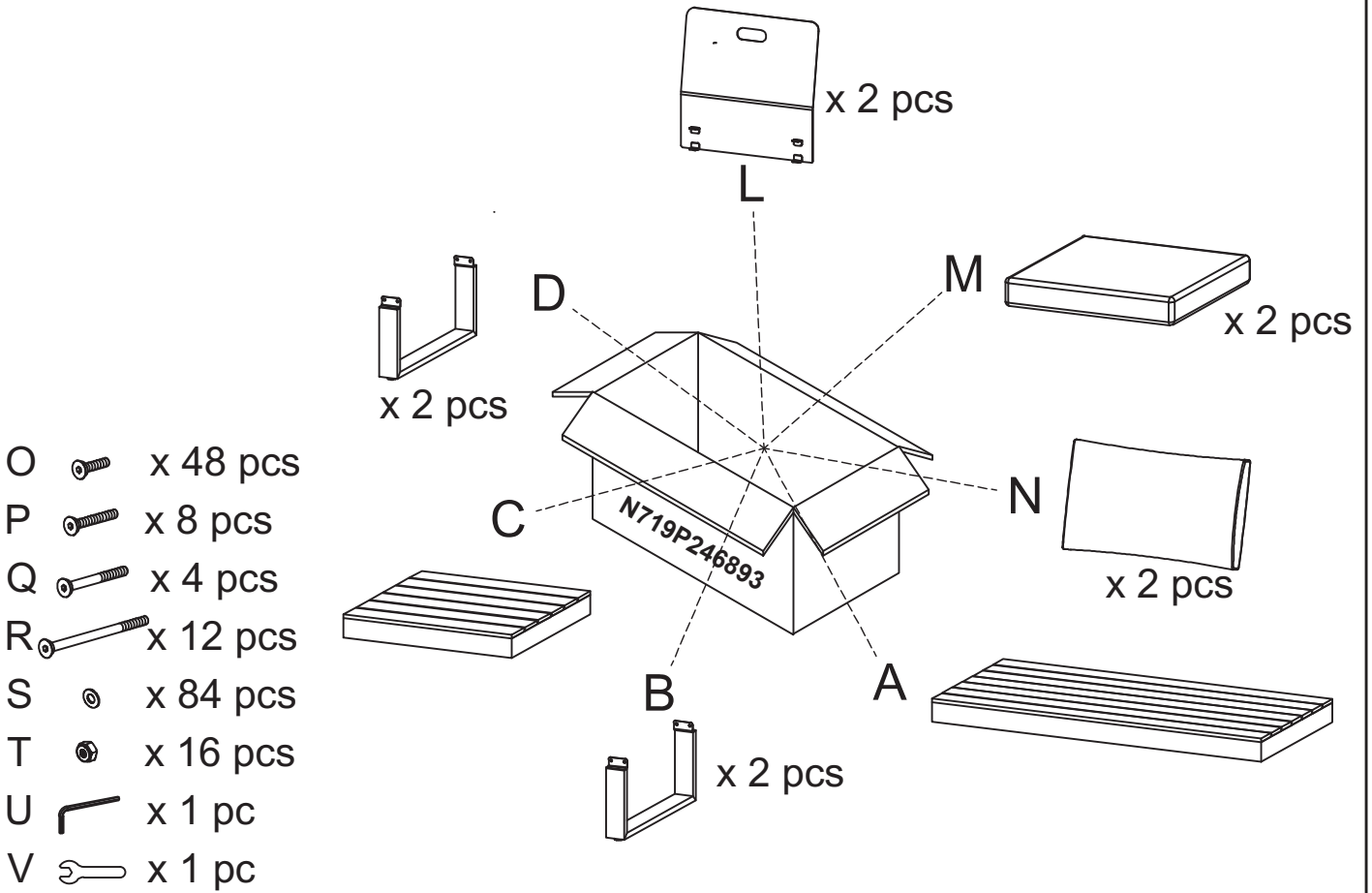

* Take out the D , E , F , I , J , K , L , M , N

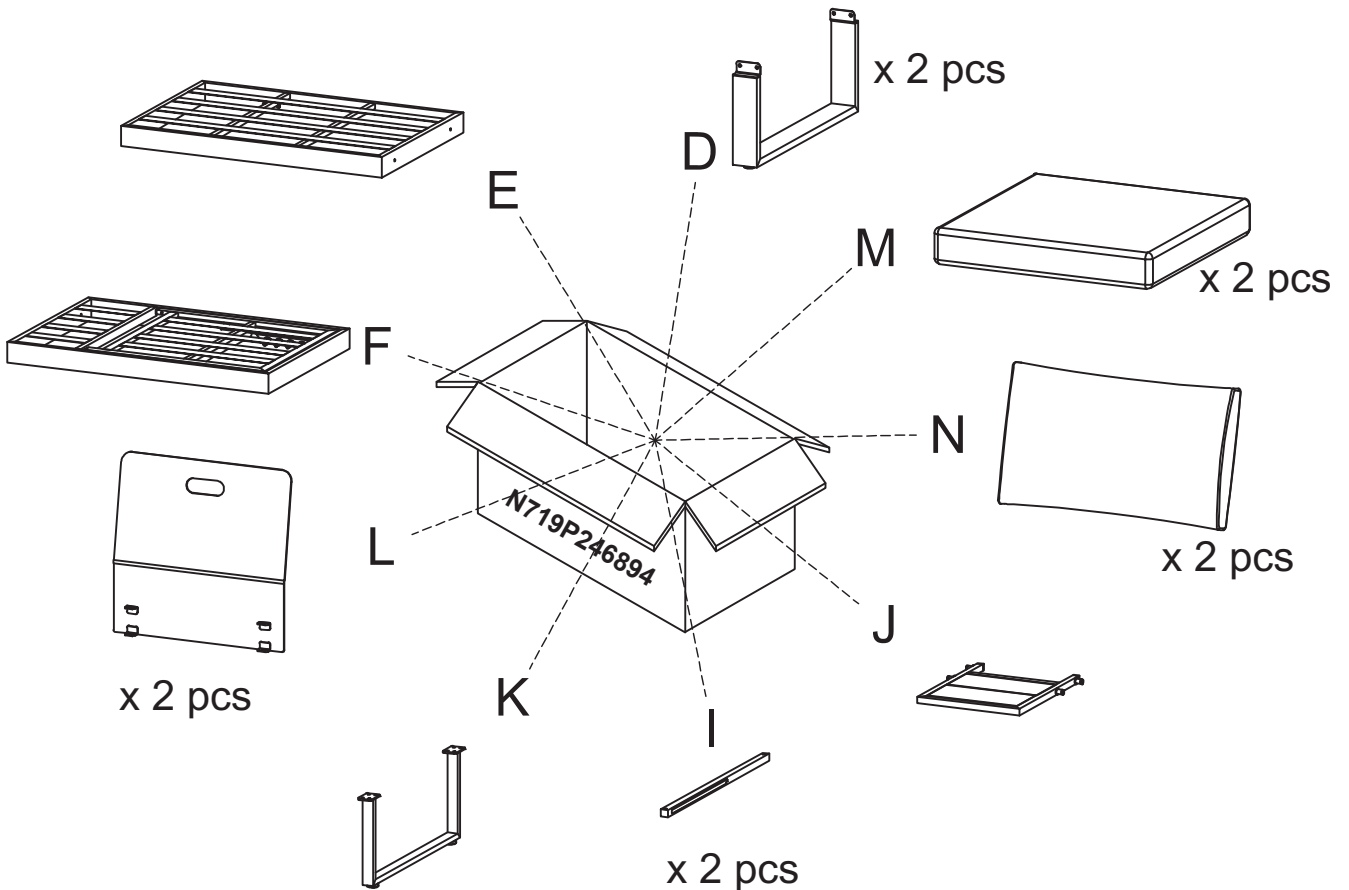



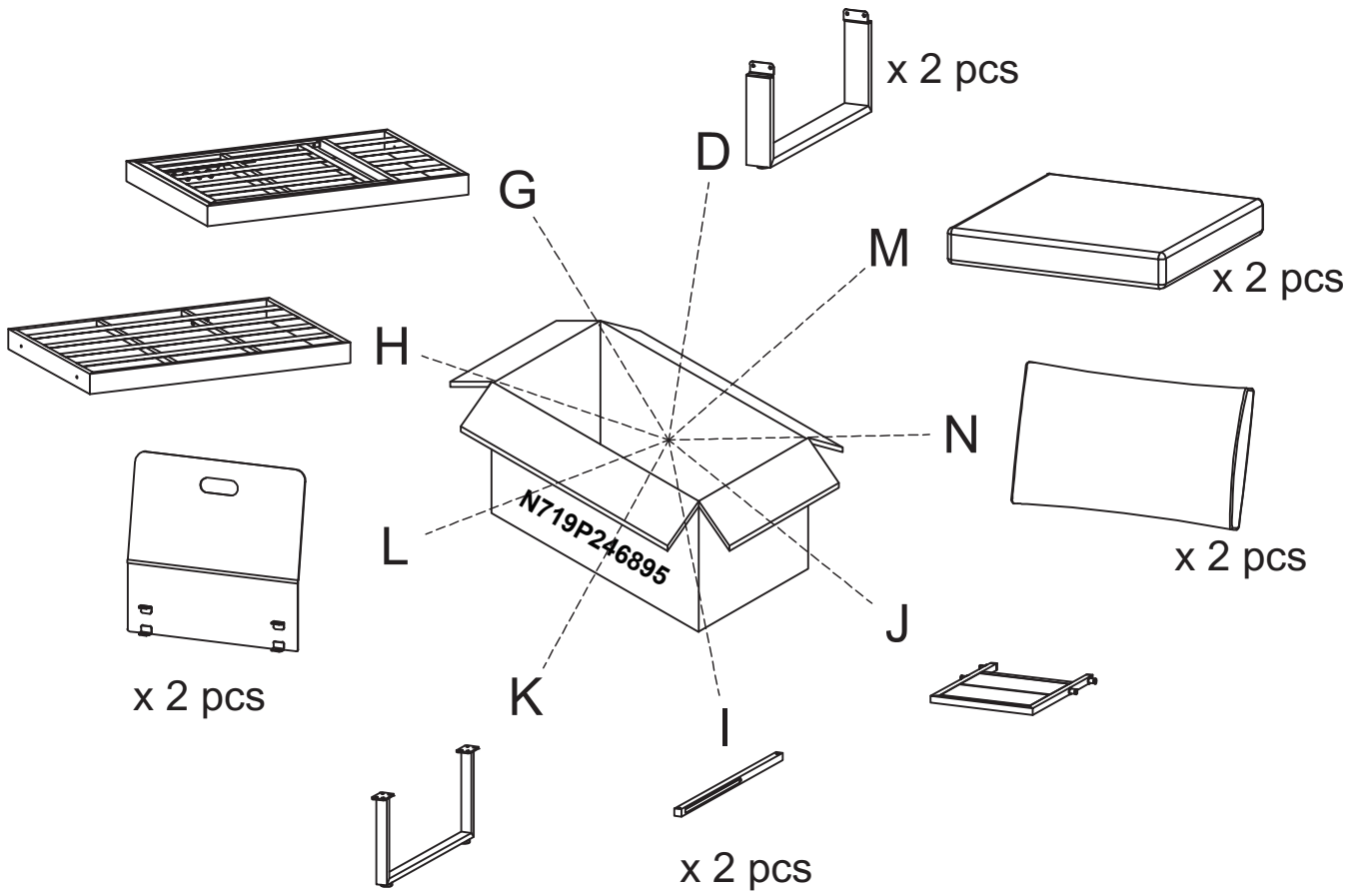



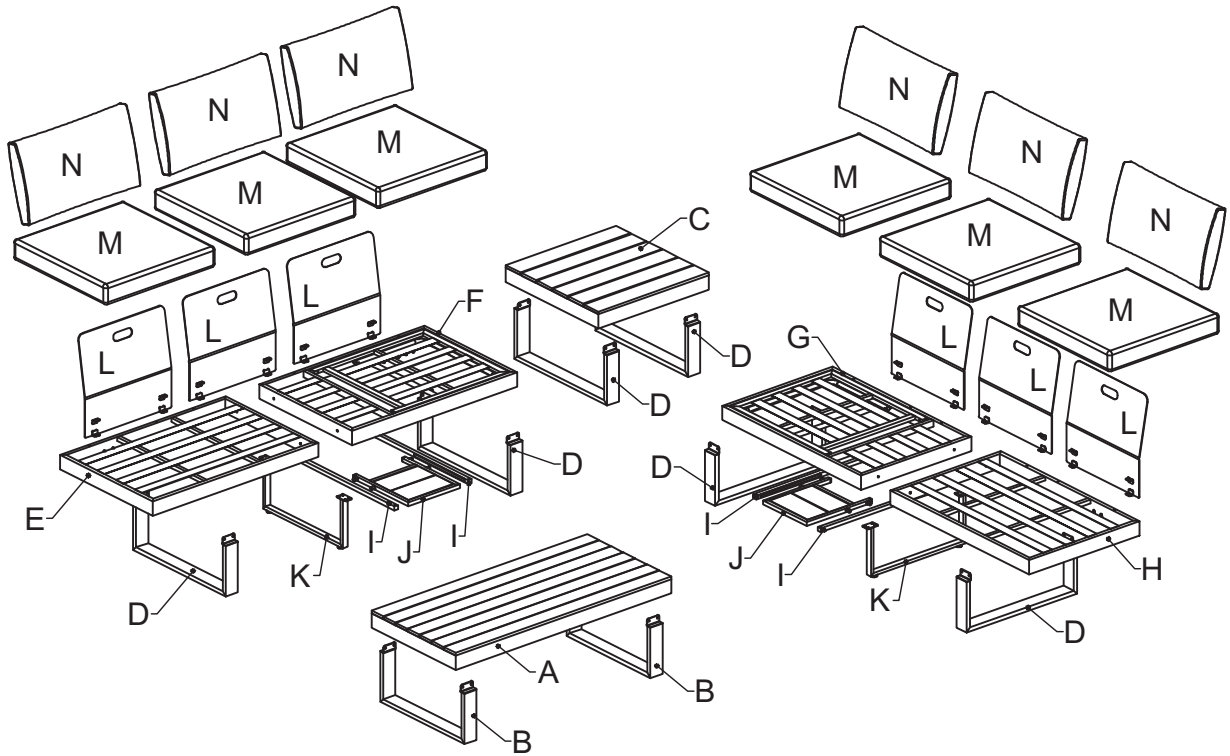

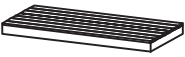









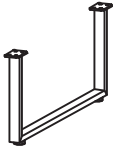

* Take out the D , G , H , I , J , K , L , M , N

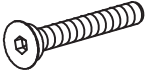
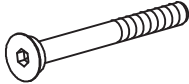



PARTS LIST



<p>A</p> 	<p>B</p> 	<p>C</p> 	<p>D</p> 	<p>E</p> 	<p>F</p> 
<p>Large coffee table frame x 1 pc</p>	<p>Big coffee table feet x 2 pcs</p>	<p>Small coffee table frame x 1 pc</p>	<p>Small coffee table leg and Sofa feet x 6 pcs</p>	<p>Sofa seat x 1 pc</p>	<p>Sofa seat x 1 pc</p>
<p>G</p> 	<p>H</p> 	<p>I</p> 	<p>J</p> 	<p>K</p> 	<p>L</p> 
<p>Sofa seat x 1 pc</p>	<p>Sofa seat x 1 pc</p>	<p>Slide rail x 4 pcs</p>	<p>Pull the side table x 2 pcs</p>	<p>Middle leg x 2 pcs</p>	<p>Tergum x 6 pcs</p>
<p>M</p> 	<p>N</p> 	<p>O</p> 	<p>P</p> 	<p>Q</p> 	<p>R</p> 
<p>Seat cushion x 6 pcs</p>	<p>Back cushion x 6 pcs</p>	<p>Hex socket screw M6*20mm x 48 pcs</p>	<p>Hex socket screw M6*35mm x 8 pcs</p>	<p>Hex socket screw M6*50mm x 4 pcs</p>	<p>Hex socket screw M6*85mm x 12 pcs</p>
<p>S</p> 	<p>T</p> 	<p>U</p> 	<p>V</p> 		
<p>Gasket x 84 pcs</p>	<p>Lock nut x 16 pcs</p>	<p>Allen key x 1 pc</p>	<p>Outer hexagonal wrench x 1 pc</p>		

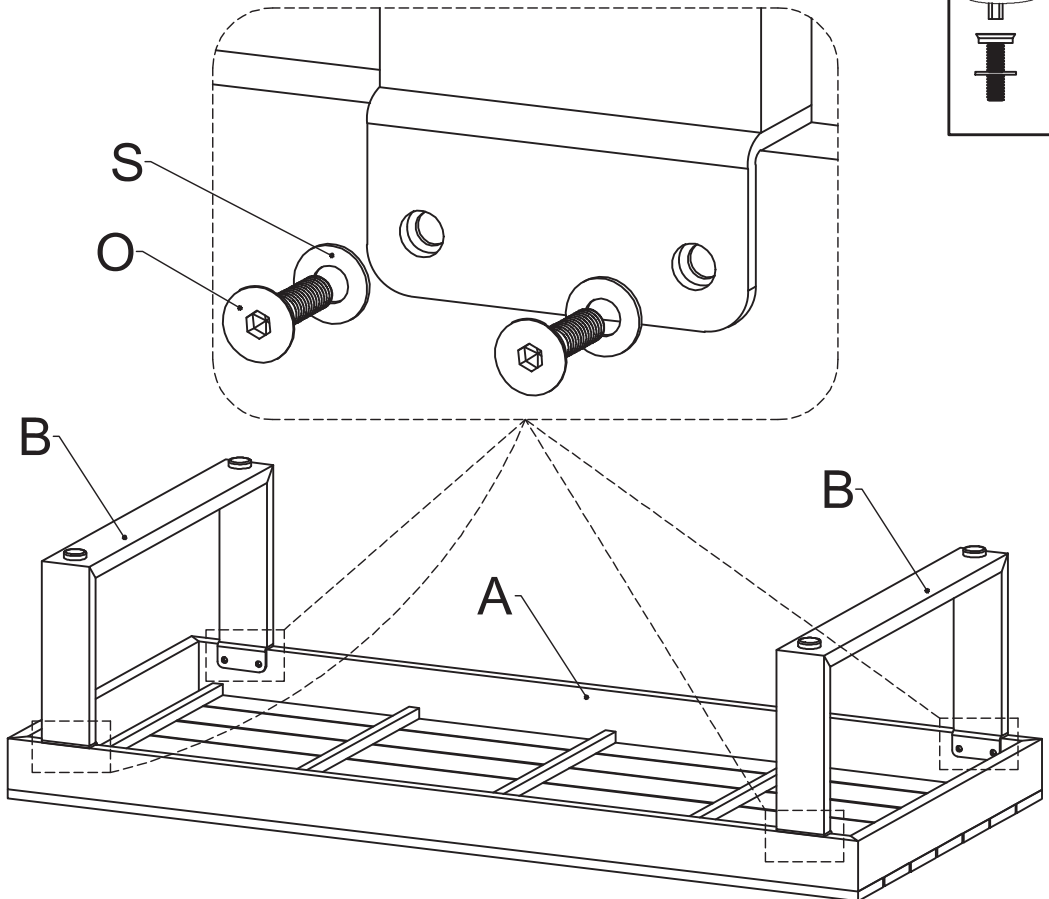
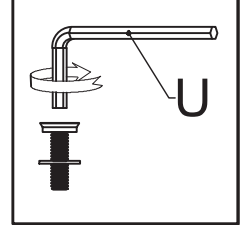

STEP 1

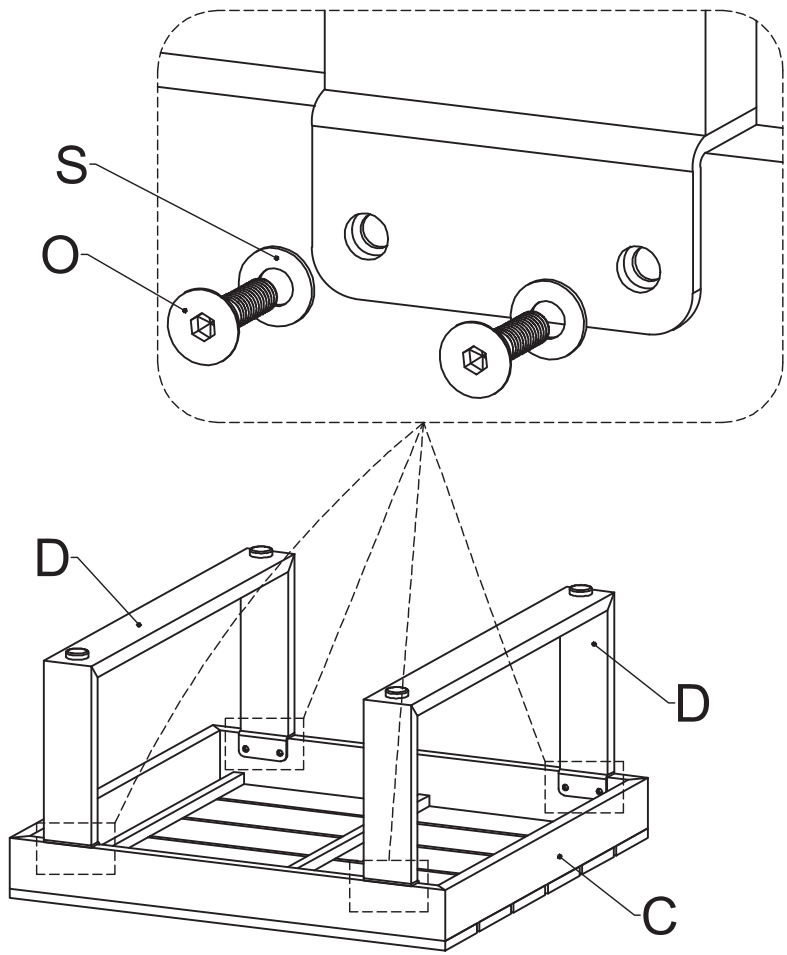
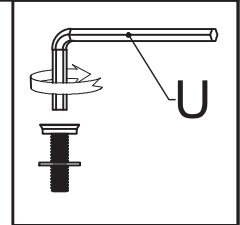

- O x 8
- 
- M6*20mm
- S x 8
- 

STEP 2

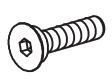

- O x 8
- 
- M6*20mm
- S x 8
- 

STEP 3

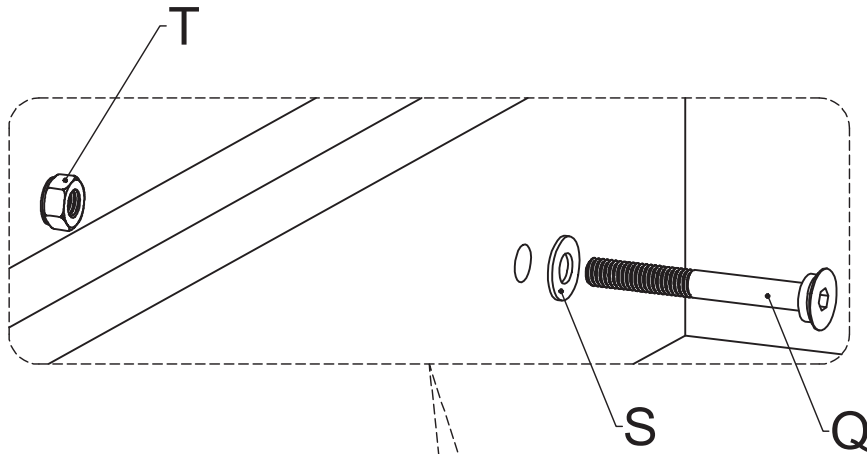

Q x 2

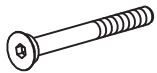

M6*50mm

S x 2



T x 2



STEP 4

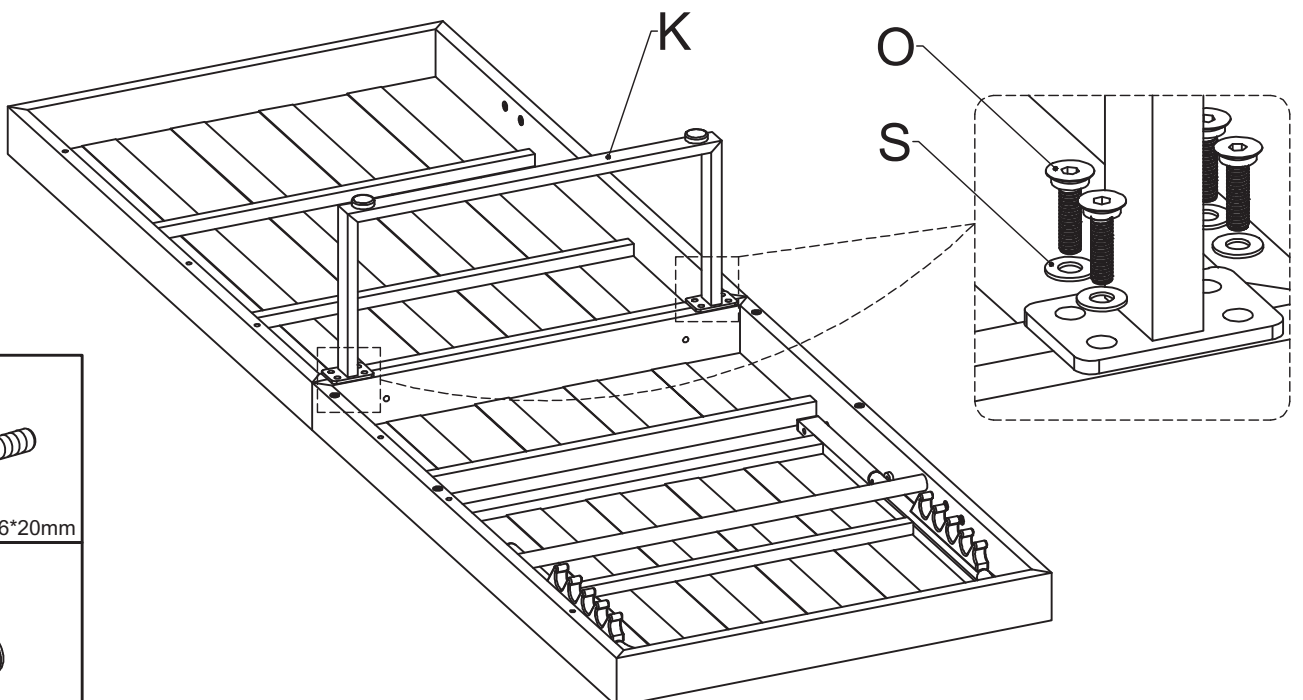

O x 8



M6*20mm

S x 8



STEP 5

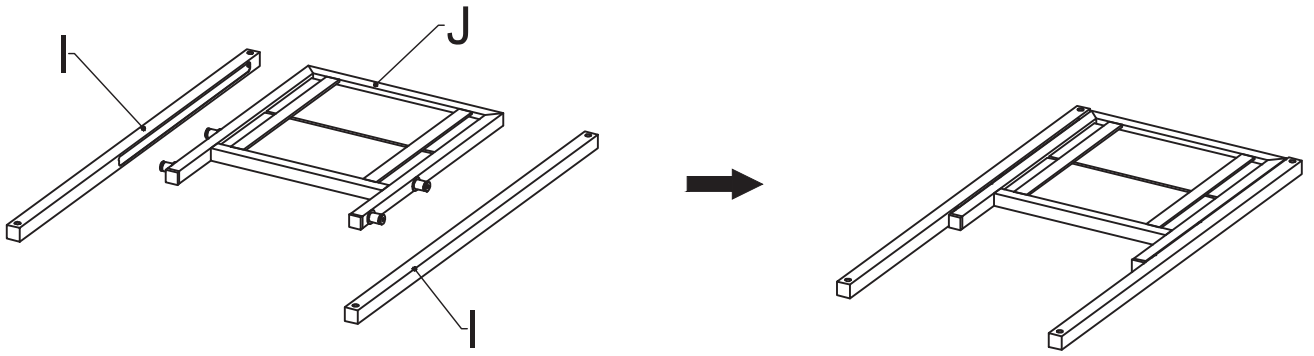

STEP 6

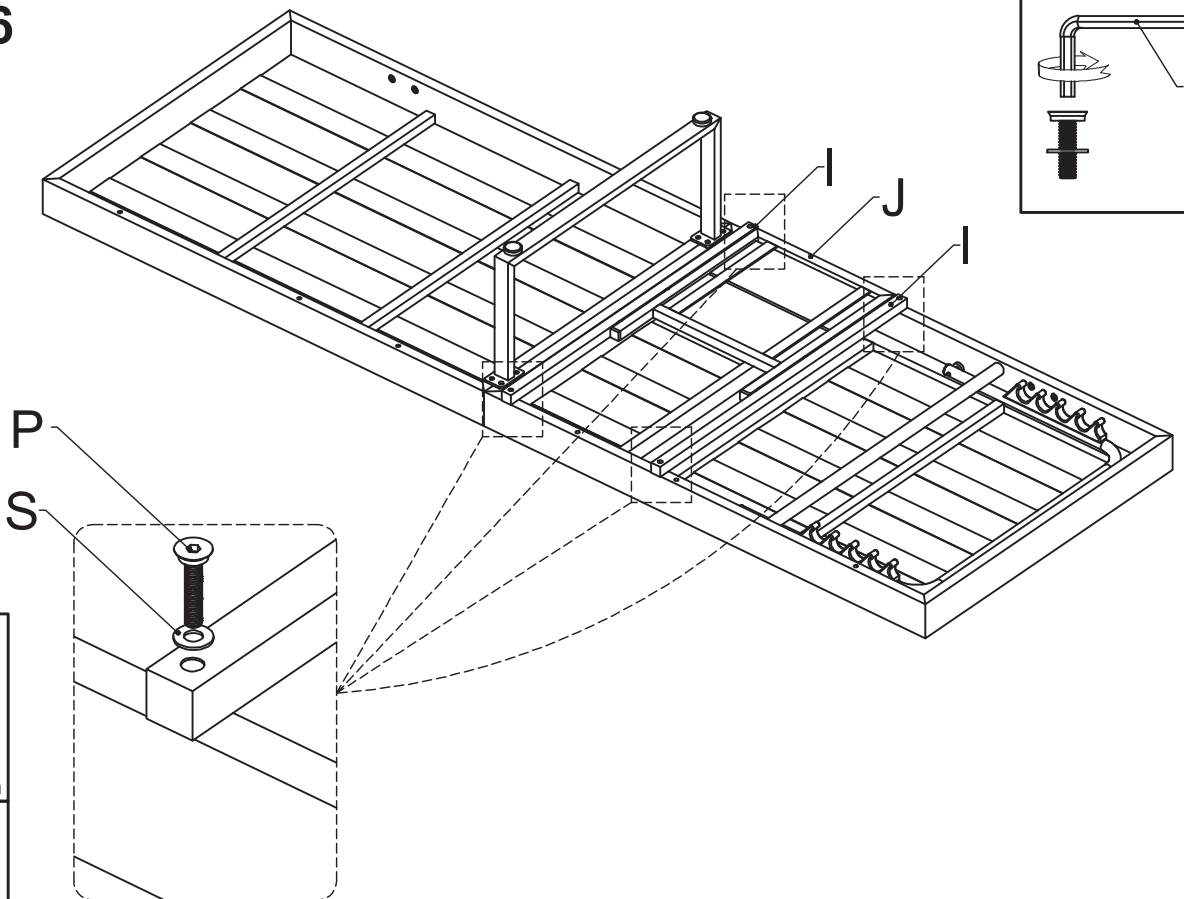

P x 4

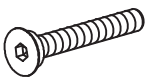

M6*35mm

S x 4



STEP 7

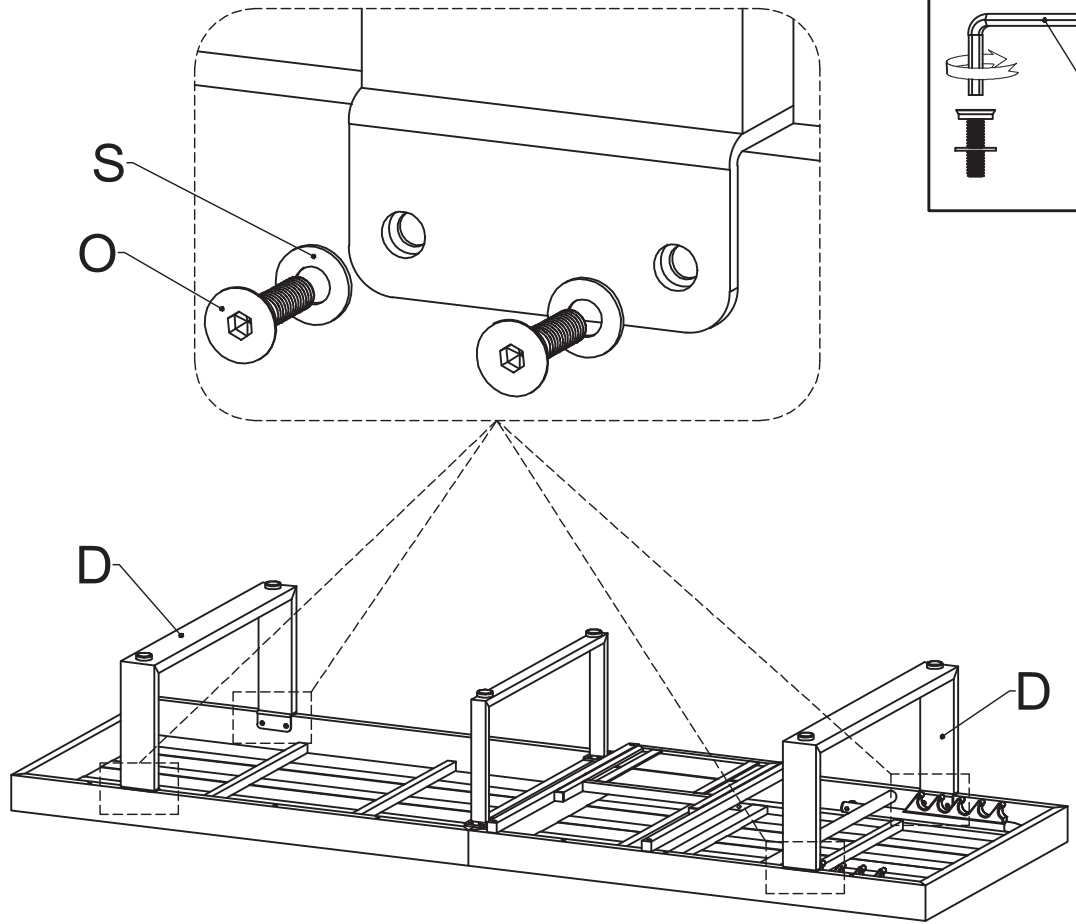

O x 8

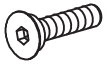

M6*20mm

S x 8



STEP 8

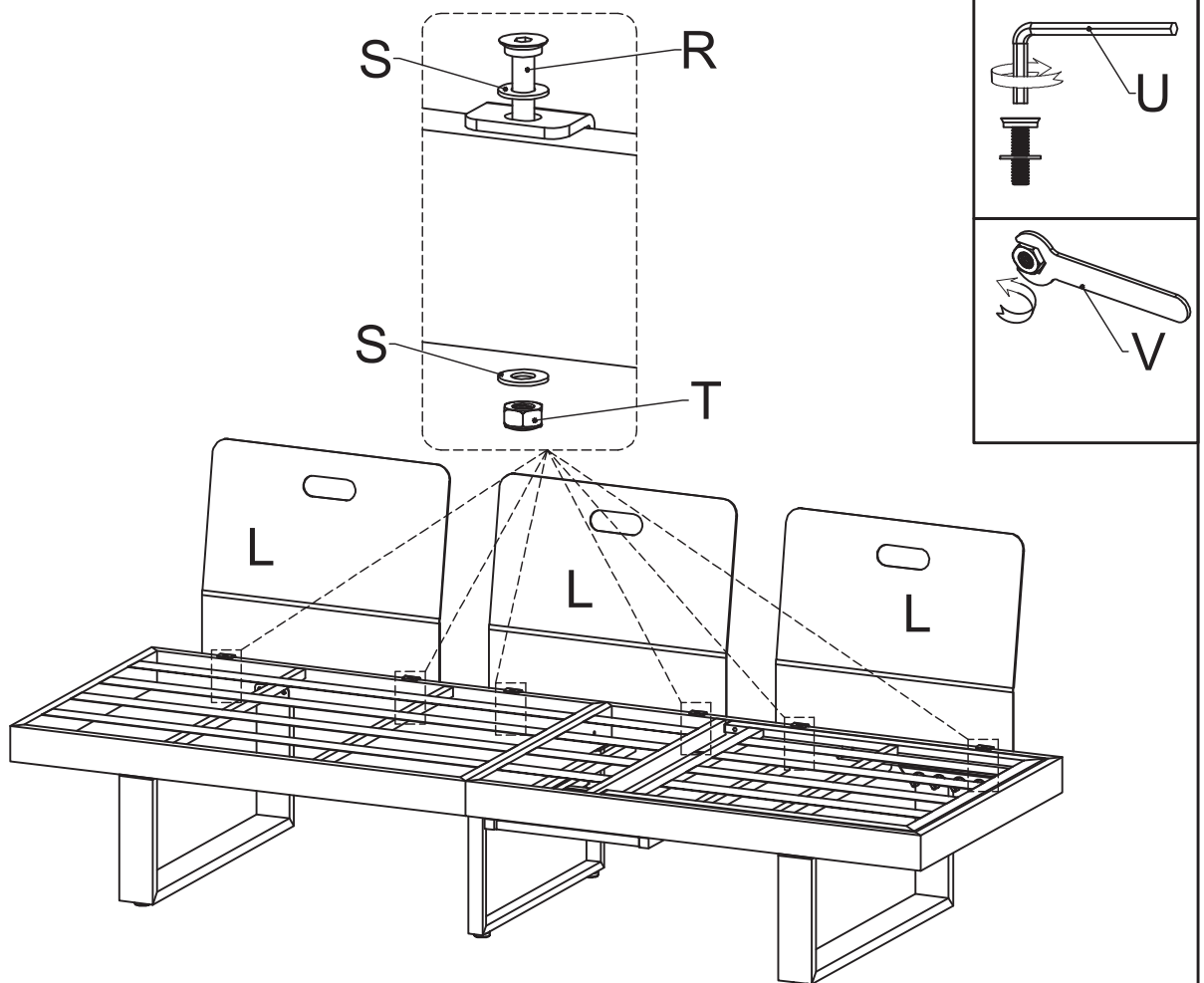

R x 6

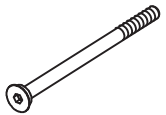

M6*85mm

S x 12



T x 6



STEP 9

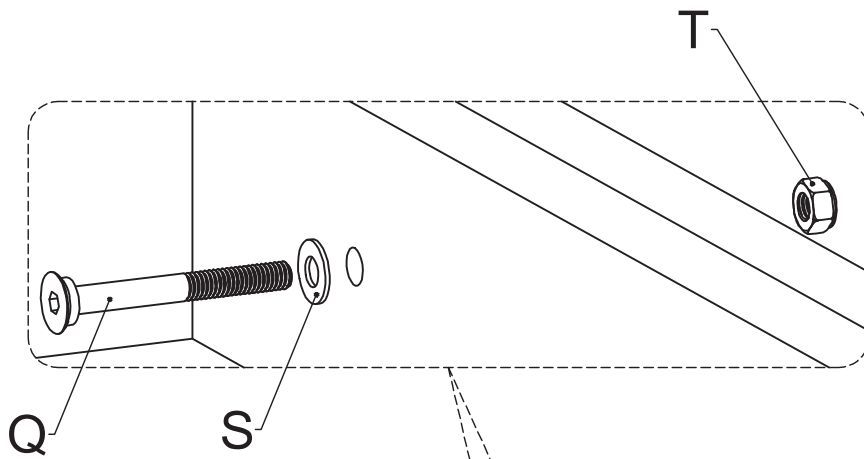

Q x 2

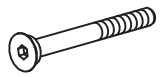

M6*50mm

S x 2



T x 2

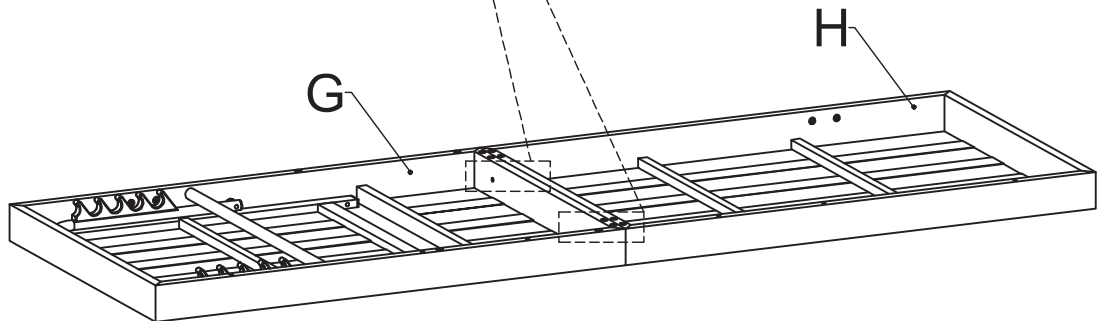

STEP 10

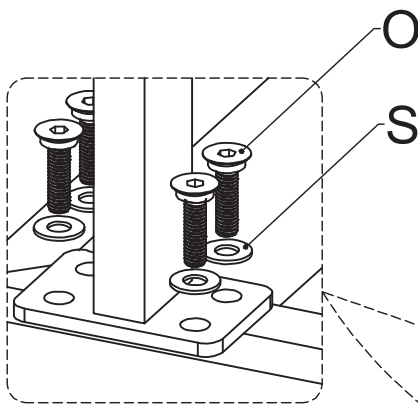

O x 8

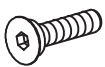

M6*20mm

S x 8

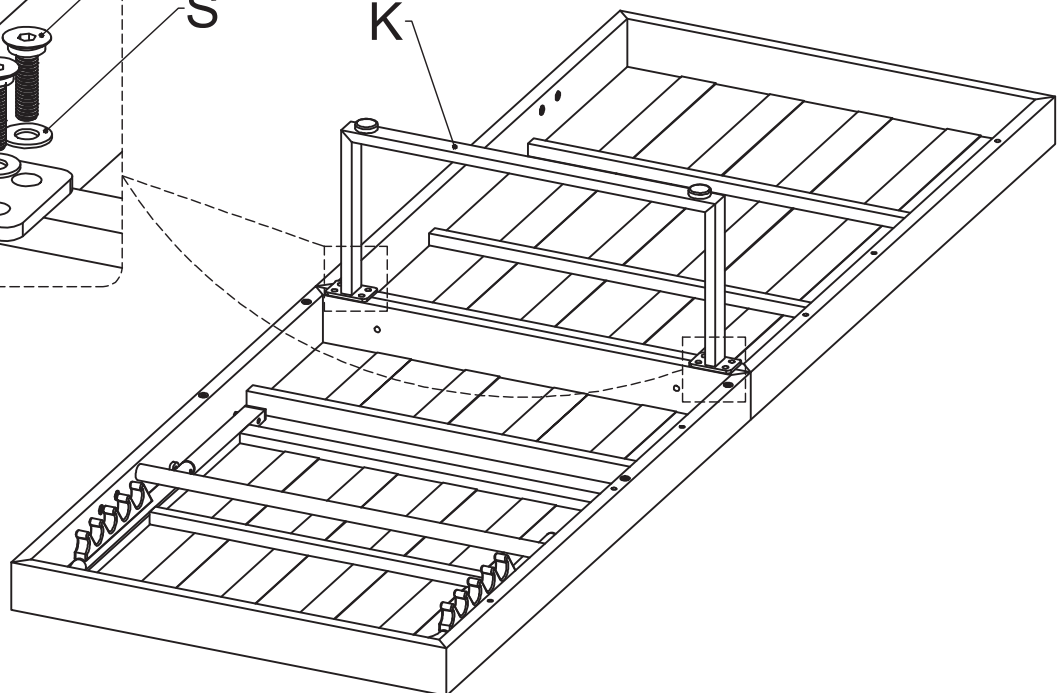

STEP 11

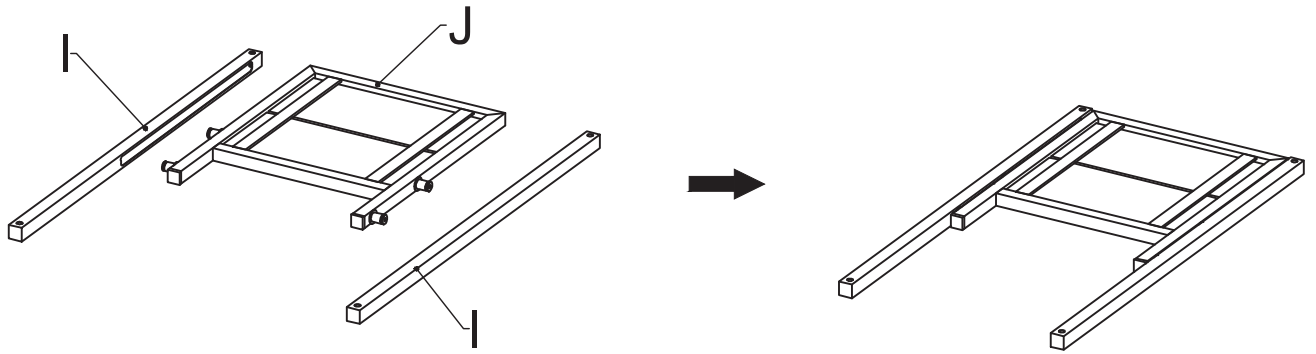

STEP 12

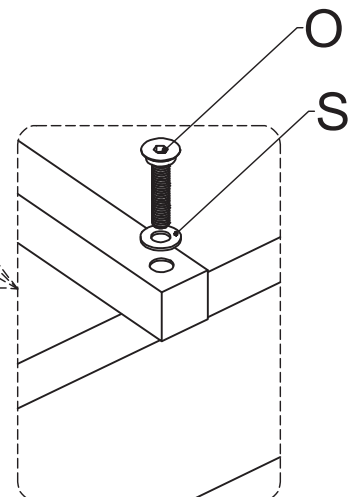
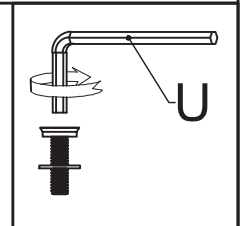
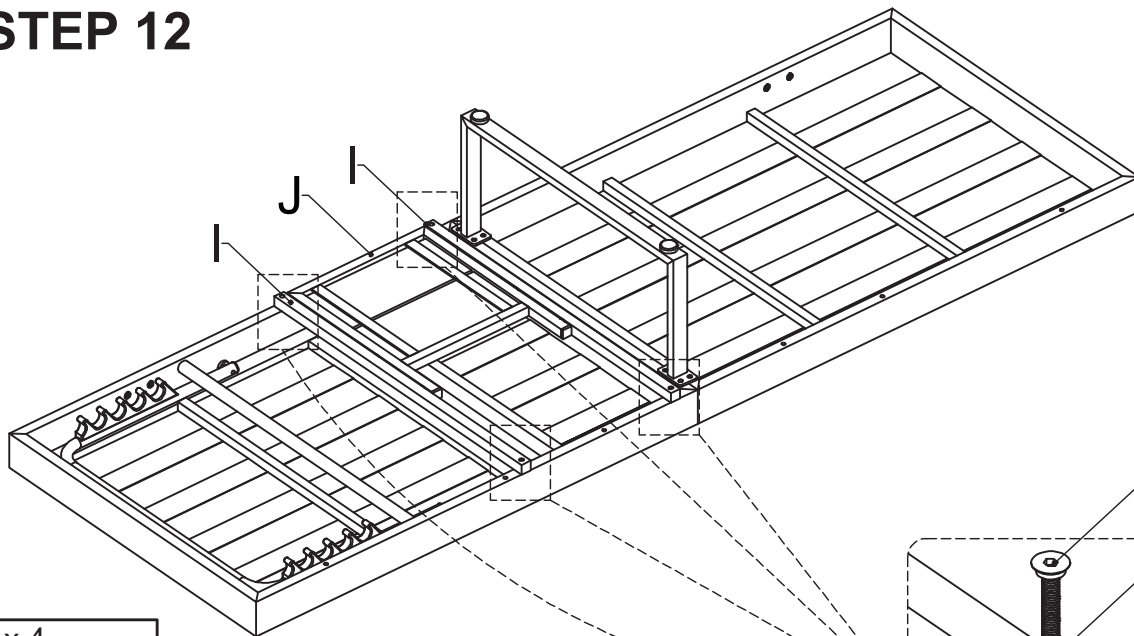

P x 4

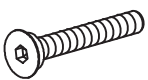

M6*35mm

S x 4



STEP 13

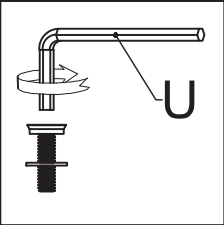
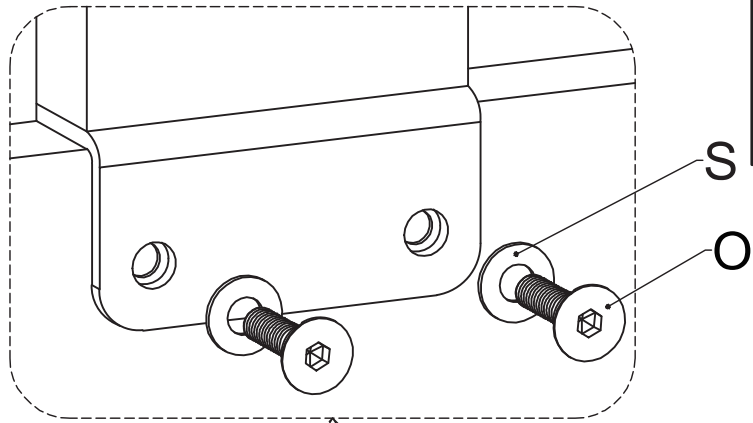

O x 8



M6*20mm

S x 8

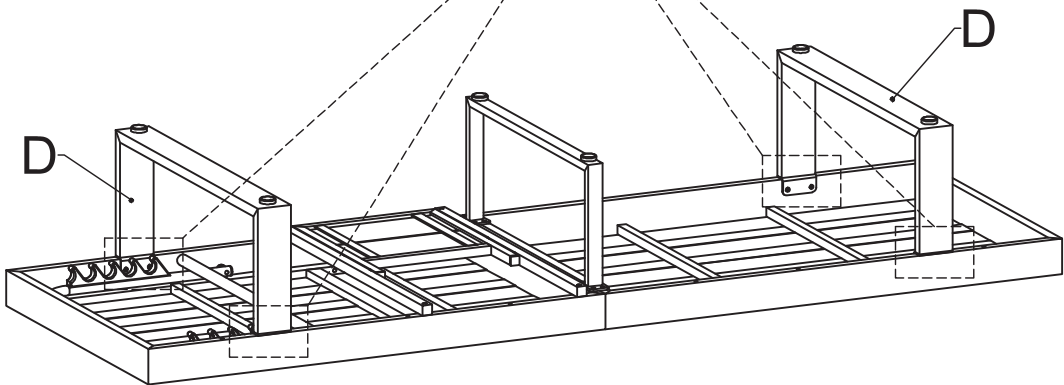

STEP 14

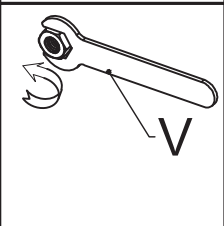
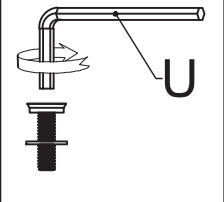
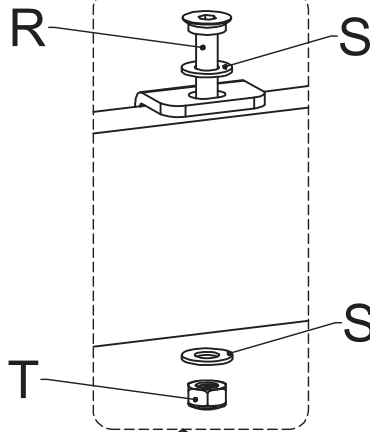

R x 6



M6*85mm

S x 12



T x 6

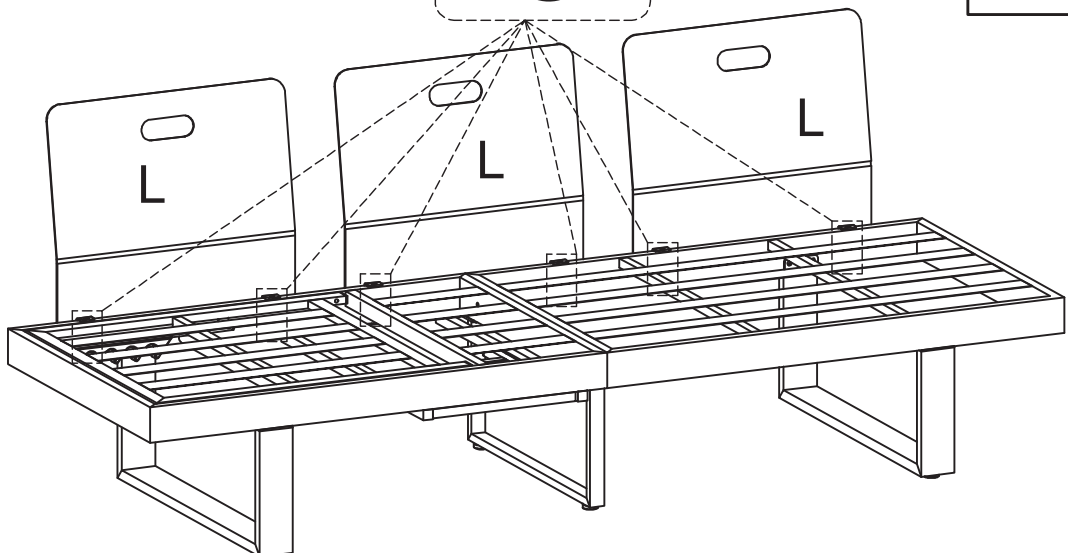

STEP 15

