

INSTALLATION GUIDE

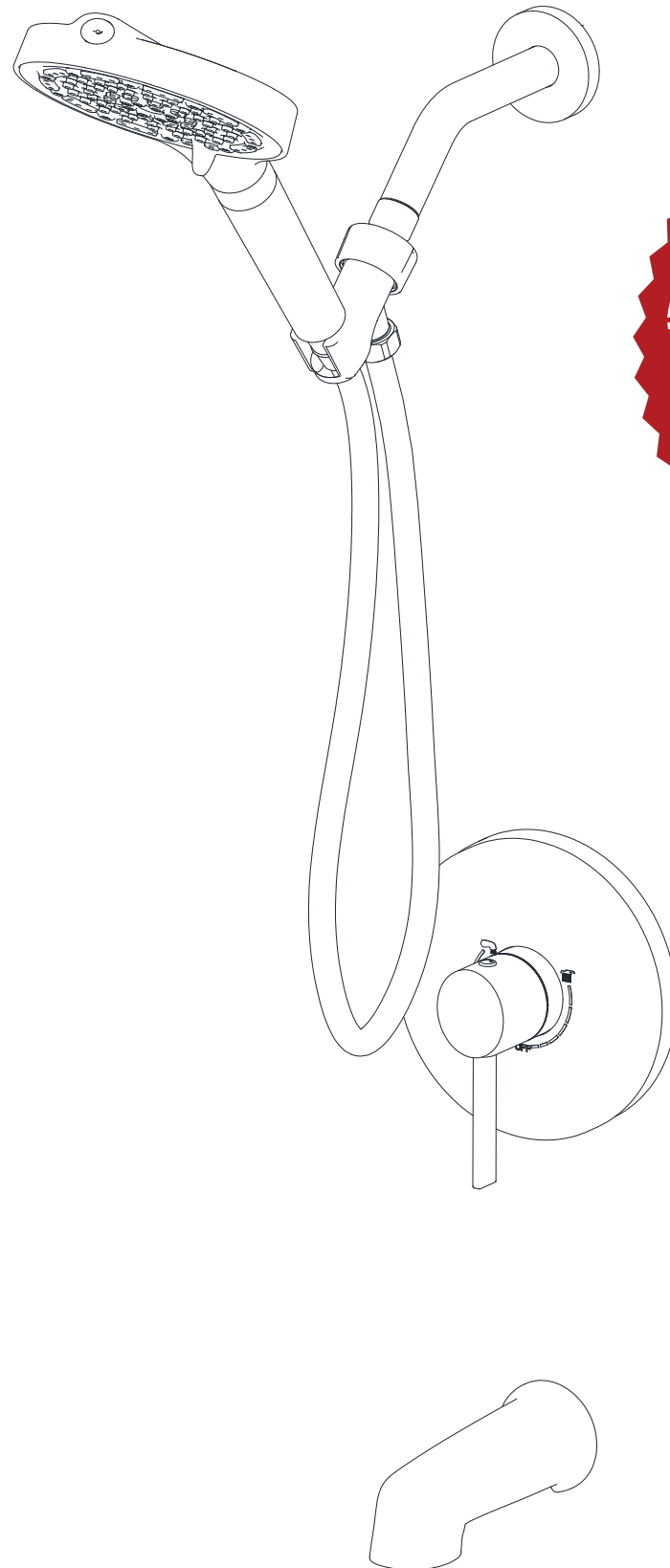

WALL- MOUNTED SHOWER SYSTEM

MODEL	FINISH
S3242I-CH	CHROME
S3242I-BN	BRUSHED NICKEL
S3242I-BG	BRUSHED GOLD
S3242I-MB	MATTE BLACK

HOT LINE: +1-866-203-0866

THANK YOU

Dear Valued Customer,

Thank you for choosing SUMERAIN products. We would like to take this opportunity to express our sincere gratitude for your recent purchase. We hope you are completely satisfied with your new product. Rest assured, we meticulously design and engineer all SUMERAIN products, subjecting them to rigorous factory testing to ensure their prolonged, trouble-free use under normal conditions.

Installing this product is straightforward. All you need are some basic tools and our handy step-by-step illustrated guide. We wholeheartedly welcome any questions or feedback you may have. We eagerly anticipate the opportunity to assist you in the future. If you have any inquiries regarding this product, please do not hesitate to contact us at +1-866-203-0866 or email us at [support@sumerain.com](mailto:supports@sumerain.com).

Once again, we extend our gratitude for selecting SUMERAIN products. We remain committed to providing exceptional customer service.

Sincerely,

SUMERAIN Customer Service Department

BEFORE PROCEEDING

1. Unpack your new product and verify that all components are present in the package. Until you are ready to install the product, keep it in its original packaging.
2. Identify the water supply inlets and turn off the water supply valves. You'll typically find these valves near the water meter. If you're replacing an existing unit, make sure to remove the old one and clean the mounting surface thoroughly.
3. Adhere to all plumbing and building codes applicable in your area.
4. If you're not confident about installing the product yourself, we strongly recommend seeking help from a professional.

TOOLS RECOMMENDED

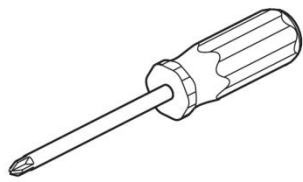

Philips Screwdriver

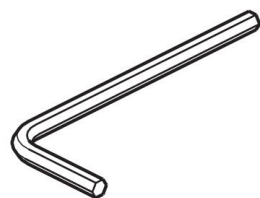

Allen Wrench

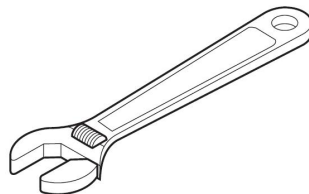

Adjustable Wrench



Channel Locks

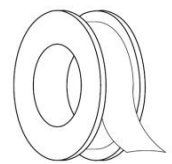

Teflon Tape

LIMITED LIFETIME CONSUMER WARRANTY

VERSION: 140320.15.3

This product has been manufactured and tested to the highest quality standards by HONGKONG SUMERAIN SANITARY INDUSTRY Co., Limited ("SUMERAIN"). This warranty applies solely to SUMERAIN products purchased by consumers in the United States after January 1st, 2020. In the event that a faucet experiences leaks or drips during regular usage, SUMERAIN will provide the necessary faucet cartridge to the purchaser, free of charge, in order to restore the faucet to proper working condition. If any defects are identified during normal residential use, SUMERAIN will, at its discretion, perform repairs, provide replacement parts or products, or make appropriate adjustments to ensure the product's optimal functionality.

WHO IS COVERED BY THE WARRANTY

This warranty provides exclusive coverage to the original consumer purchaser, including those who have made purchases through online retail platforms. However, online retail customers who are specifically covered by the "Online CONSUMER Limited Lifetime WARRANTY & Return policy" are also included. Please note that this warranty is non-transferable and cannot be assigned to any other party.

WHAT IS COVERED BY THE WARRANTY

This warranty is applicable only to the SUMERAIN manufactured product that you have purchased. SUMERAIN provides the following warranty against defects in material or workmanship: under normal installation, use, service, and maintenance, if the product or any of its components prove to be defective due to improper workmanship or materials, SUMERAIN will, at its discretion, provide free replacement parts or replace the entire product.

FINISH WARRANTY

Customers are responsible for thoroughly inspecting the product for any material or finish defects within three days of receiving it. Please note that SUMERAIN does not cover surface finish defects under warranty once the fixture has been installed.

ELECTRONIC FAUCETS WARRANTY

SUMERAIN guarantees its LED components, including electronic faucets, valves, controllers, and battery-powered devices, against material and manufacturing defects for one year from the date of purchase, under normal use. The water flow impeller power device (LED faucet power generation device) is guaranteed to be free from manufacturing defects for the first three months from the date of purchase.

LENGTH OF WARRANTY

As stated in the following, any replacement or repaired parts of the product will be covered for the duration of this warranty, which SUMERAIN provides for a period of 1 year from the original date of purchase.

CIRCUMSTANCES THAT SUMERAIN WILL NOT WARRANT AND PAY FOR:

- A. Conditions, malfunctions, or damage that do not result from defects in material or workmanship.
- B. Conditions, malfunctions, or damage resulting from normal wear and tear, improper installation, improper maintenance, misuse, abuse, negligence, accidents, alterations, or the use of abrasive or caustic cleaning agents, "no-rinse" cleaning products, or the product in a manner contrary to the provided instructions. This includes home conditions such as excessive water pressure or corrosion.
- C. Labor or other expenses associated with disconnection, deinstallation, or return of the product for warranty service, as well as installation or reinstallation of the product.
- D. Accessories, connected materials, and products (including but not limited to hand shower flexible hose, spray flexible hose, hand shower, shower head), or related products that are not manufactured by SUMERAIN.

TO OBTAIN WARRANTY PARTS OR INFORMATION

To obtain warranty parts or information professionally, please follow the steps below:

Contact your SUMERAIN retailer or dial the technical service phone number at +1-866-203-0866, or send an email to supports@sumerain.com.

When applying for warranty service, you will need to provide the following information:

- a. Sales receipt or other evidence of purchase date and platform.
- b. Detailed description of the problem.
- c. Ship the product or defective parts to the designated SUMERAIN warehouse in the United States with prepaid postage. Please ensure careful packaging and insurance of the items. Once the warranty service is completed, any repaired or replaced products or parts will be shipped back to you with prepaid postage.

If you have any further questions or need additional assistance, please contact the provided contact information.

EXCLUSIONS & LIMITATIONS

Pursuant to the terms of this warranty, repair, replacement (or, in limited circumstances, refund of the purchase price) shall be the sole remedy available to the purchaser. SUMERAIN assumes no obligations or liabilities and does not authorize any individual to create obligations or liabilities in relation to this product. SUMERAIN shall not be held liable to the purchaser or any party for any incidental, special, or consequential damages resulting from a breach of this warranty or any implied warranties (including merchantability). Please note that certain states do not allow the exclusion or limitation of incidental or consequential damages, therefore the aforementioned limitation or exclusion may not apply to you. This warranty grants you specific legal rights, and you may also have additional rights that vary from state to state. Before initiating any legal proceedings against us under the Magnuson-Moss Warranty Act, you may be legally required to provide us with a reasonable opportunity to rectify or resolve any non-compliance.

PRODUCT INSTRUCTIONS & QUESTIONS

Prior to installation, we strongly recommend conducting a meticulous inspection of your SUMERAIN product to identify any potential damage or visible defects. It is crucial to thoroughly review the accompanying instructions regarding the correct installation, maintenance, and care procedures for the product. Should you have any inquiries regarding the utilization, installation, performance, or this warranty of your SUMERAIN product, please don't hesitate to reach out to us at +1-866-2030-866 or via email at supports@sumerain.com. Our dedicated team is readily available to provide professional assistance and address any concerns you may have.

FUNCTIONS & SPECIFICATIONS

Faucet Type	Shower System
Feature	Concealed Shower Faucet
Theme	Modern, Contemporary
Mounting Type	Wall Mount
Finish	Chrome, Brushed Nickel, Matte Black, Brushed Gold
Number Of Handles	One
Handles Material	Metal
Handle Style	Lever
Shower Arm Reach	17-5/16 Inch
Valve Type	Φ 35 Ceramic Cartridge
Faucet Body Material	Brass
Escutcheon Material	Zinc Alloy
Diverter Included	Yes
Diverter Location	Rough-in Valve
Handheld Shower Function	Six Function
Handheld Shower Material	Plastic
Handheld Shower Flow Rate	1.8 GPM @60PSI
Spout Rate	6.45GPM @60PSI
Length of Spout	6 Inch
Net Weight	5.27lbs
Gross Weight	7.21lbs
Packing Box [L x W x H]	19-11/16Inchx13-19/32Inchx5-5/16Inch

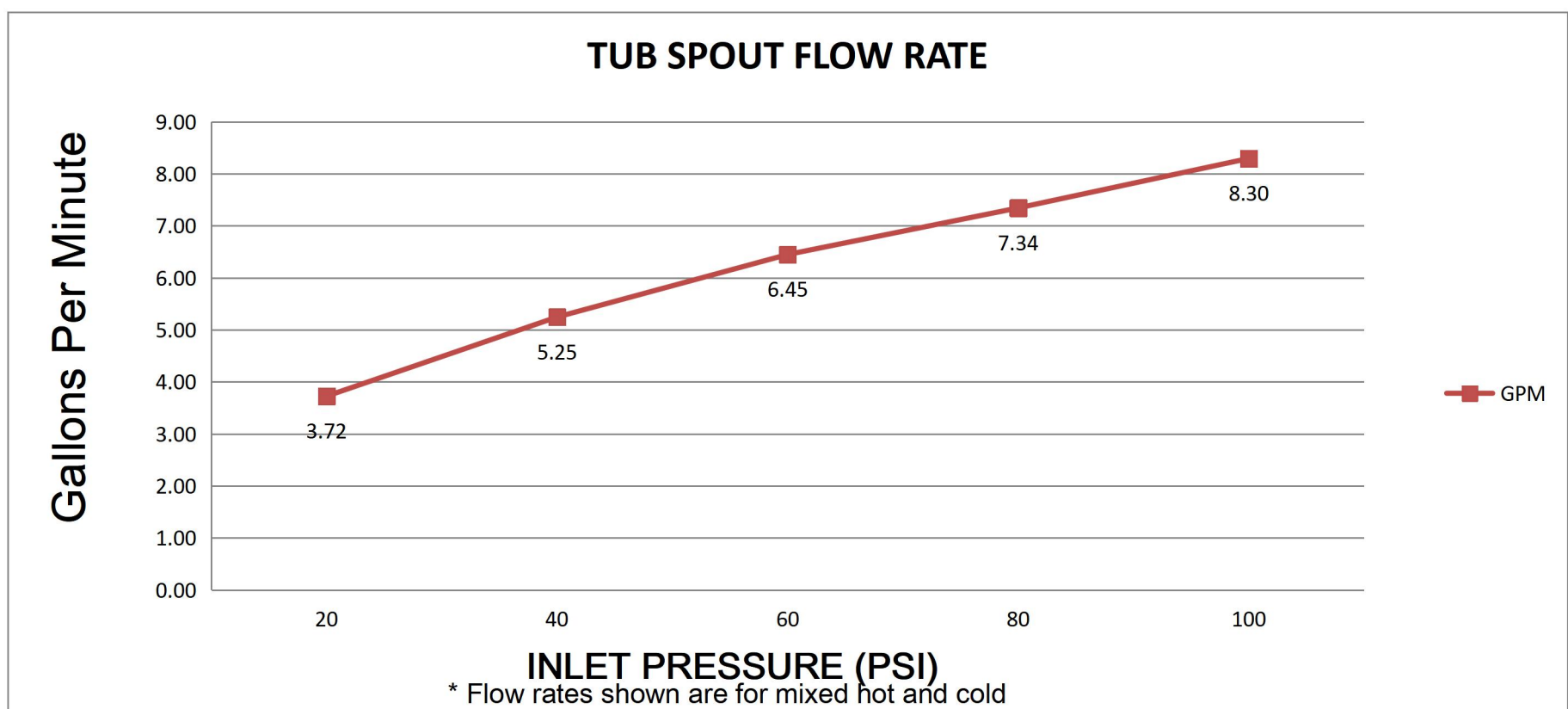

DIMENSION

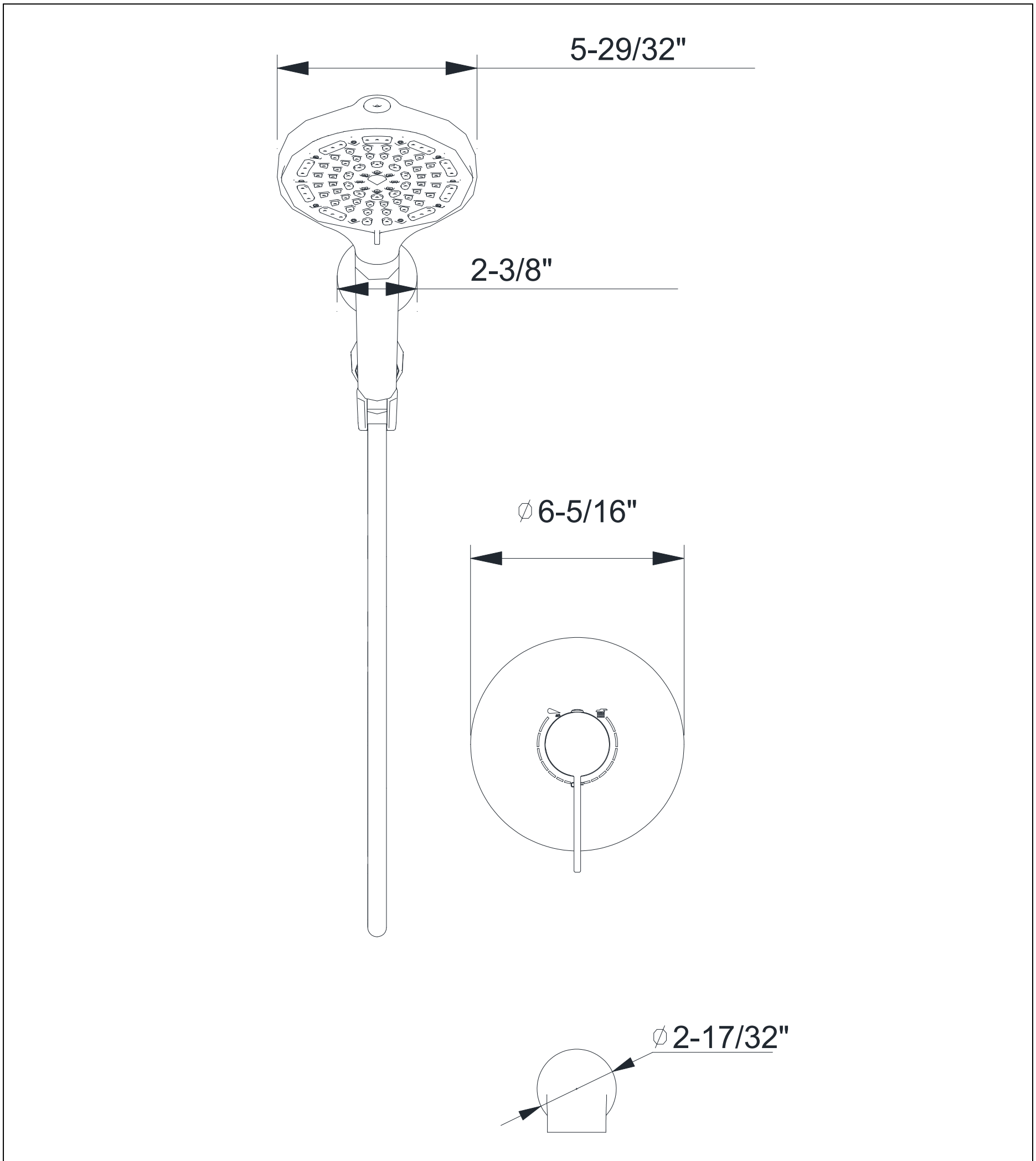

FRONT VIEW OF SHOWER

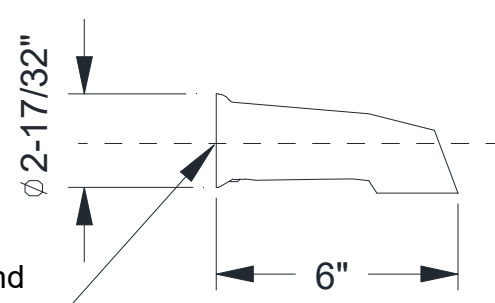
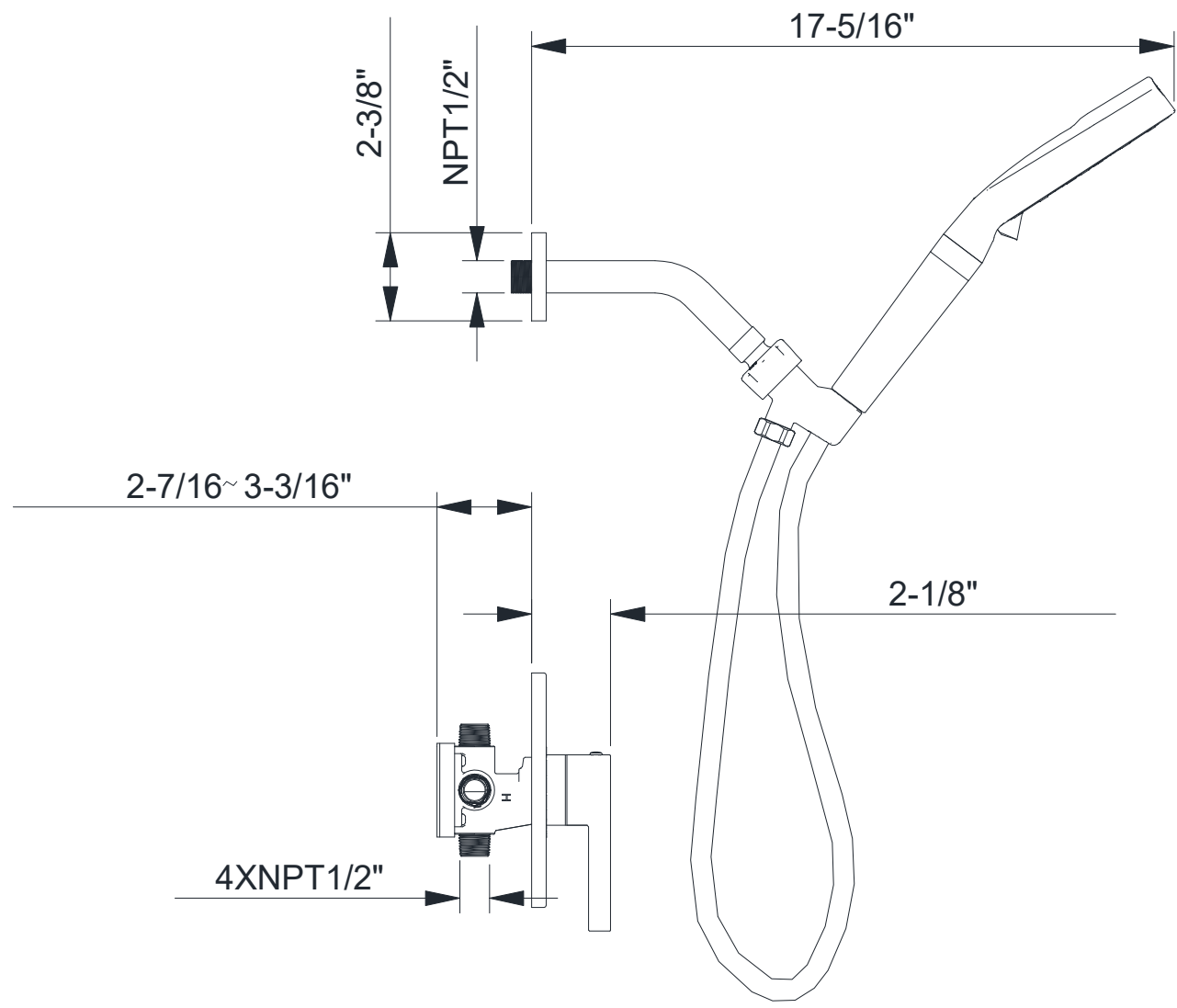

1/2" NPT Pipe or 5/8" OD Tubing
 - For slip-fit spout, tubing must extend 13/16" Min; 3-15/16" Max beyond finished wall.
 - For 1/2" NPT spout, pipe must extend 4.0" beyond finished wall.

SIDE VIEW OF SHOWER

INSTALLATION STEPS

1. BEFORE PROCEEDING



WARNING: Before proceeding with any operation, please read all instructions thoroughly. If you are uncertain about installing this product, please consult a professional! This product should be installed in accordance with all local and state plumbing and building codes. It is recommended to seek professional assistance.

2. SHUT OFF WATER SUPPLY

Locate the water supply inlets and shut off the corresponding water supply valves, typically found near the water meter. If replacing an existing unit, remove the old unit and thoroughly clean the mounting surface.

3. CHECKING THE CONTENTS OF THE BOX

Upon opening the box, check to ensure that all the following items are included.

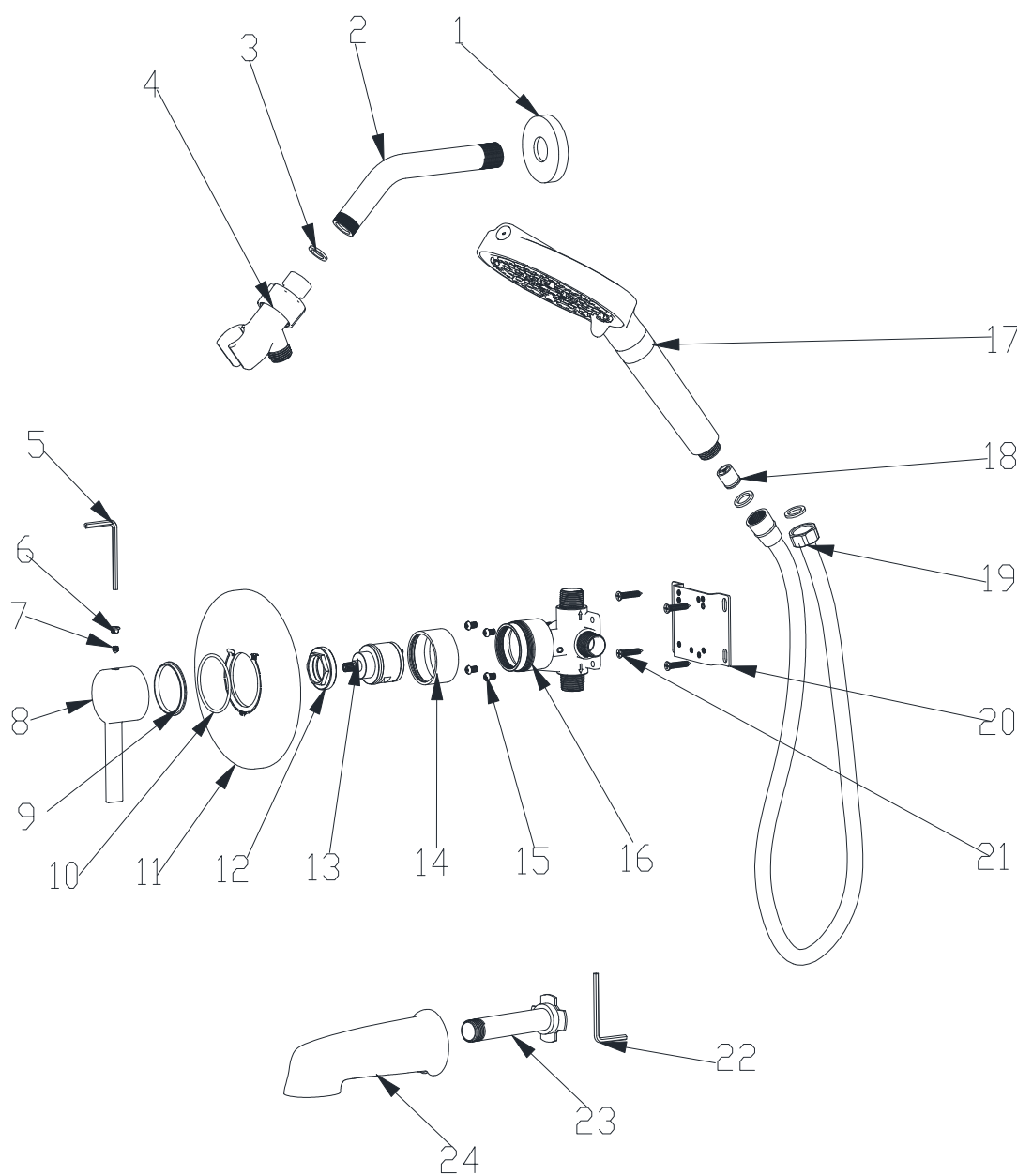

NO	ITEM NAME	MATERIAL	QTY	PART NO.	NO	ITEM NAME	MATERIAL	QTY	PART NO.
1	Shower Arm Flange	SUS304	1	PFC00001XX	13	Cartridge with 2 Outlet	ASSEMBLE	1	PCT35002XX
2	Shower Arm	SUS304	1	PPI32300XX	14	Sleeve	HPB59-1	1	PSL32400XX
3	Rubber Washer	NBR	3	PRW19020XX	15	Set Screw	SUS304	4	PSC05085XX
4	Hand Shower Holder	ASSEMBLE	1	PHH32420XX	16	Valve Body	HPB59-1	1	PVB32401XX
5	Allen Wrench 2.8mm	Fe45#	1	PSA00003XX	17	Handheld Shower	ASSEMBLE	1	PHS32420XX
6	Screw Cover	PVC	1	PSA00002XX	18	Check Valve	ASSEMBLE	1	PAE00044XX
7	Set Screw	SUS304	1	PSC05051XX	19	Shower Hose	ASSEMBLE	1	PFH00010XX
8	Handle(lever)	Zn Alloy No.3	1	PHD32400XX	20	Mounting Bracket	SUS304	1	PSA32400XX
9	T-Washers	POM	1	PRW48452XX	21	Set Screw	SUS304	4	PSC00004XX
10	O-Ring	NBR	1	POR53025XX	22	Allen Wrench 4mm	Fe45#	1	PSA00039XX
11	Escutcheon	Zn Alloy No.3	1	PCP32400XX	23	Spout Adapter(ASSEMBLE	1	PSA32410XX
12	Bonnet	HPB59-1	1	PSC38125XX	24	Spout	Zn Alloy No.3	1	PSP32410XX

If any of these items are missing, please contact SUMERAIN consumer service by email to: supports@sumerain.com.

4. PLANNING AND INSTALLATION INSTRUCTIONS



Attentions: The shower has to be installed, rinsed and checked in compliance with the applicable regulations in order to guarantee proper shower function!

The dimensions of the shower set-up must be individually.

Operating pressure at the control valve:

Max. 145PSI. Recommended operating pressure: 43.5PSI.

Hot water temperature: Max 140 Fahrenheit (60 degree centigrade).

5. Rough-in Valve Installation

5.1 Construct a wooden mounting rack to secure the rough-in valve assembly. Position the face of the mounting board between 2-7/16" and 3-3/16" behind the finished wall surface.

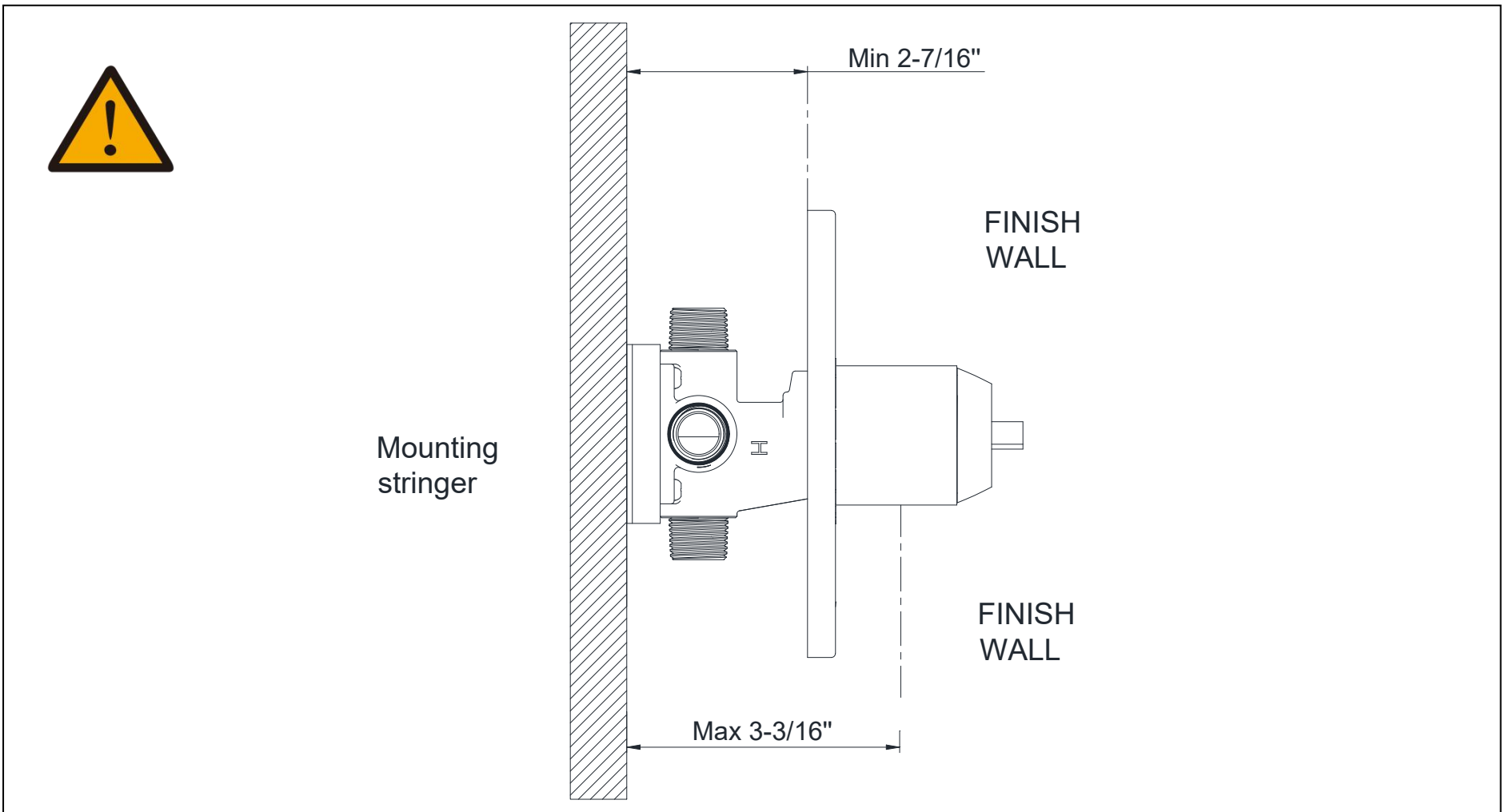
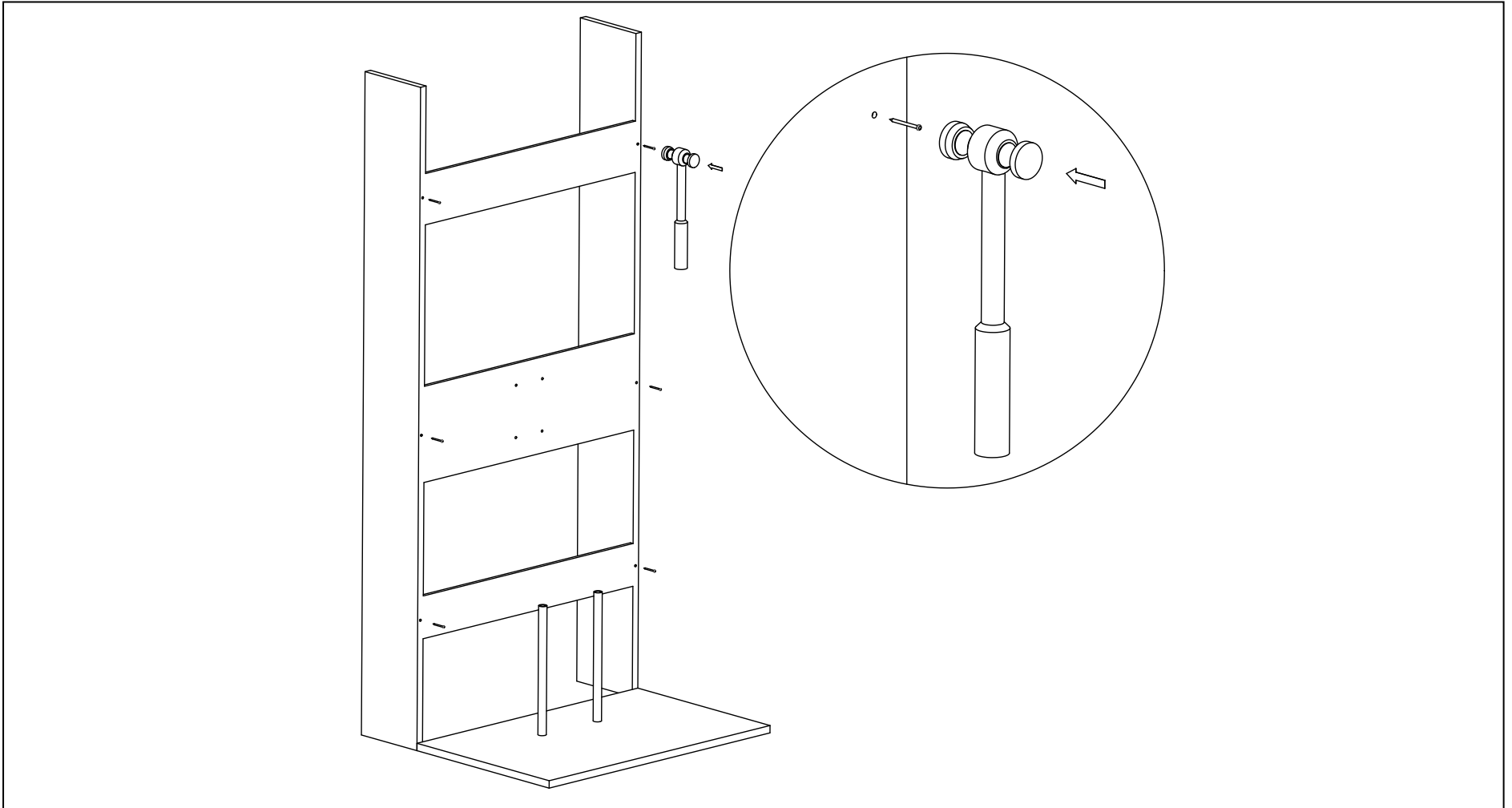

5.2 Turn on your shut-off valve for cleaning the hot and cold water supply pipe before connect to the valve body, allow the water flush 3~5 minutes to flush out dirt and debris. Shut off the water supply again after finish.

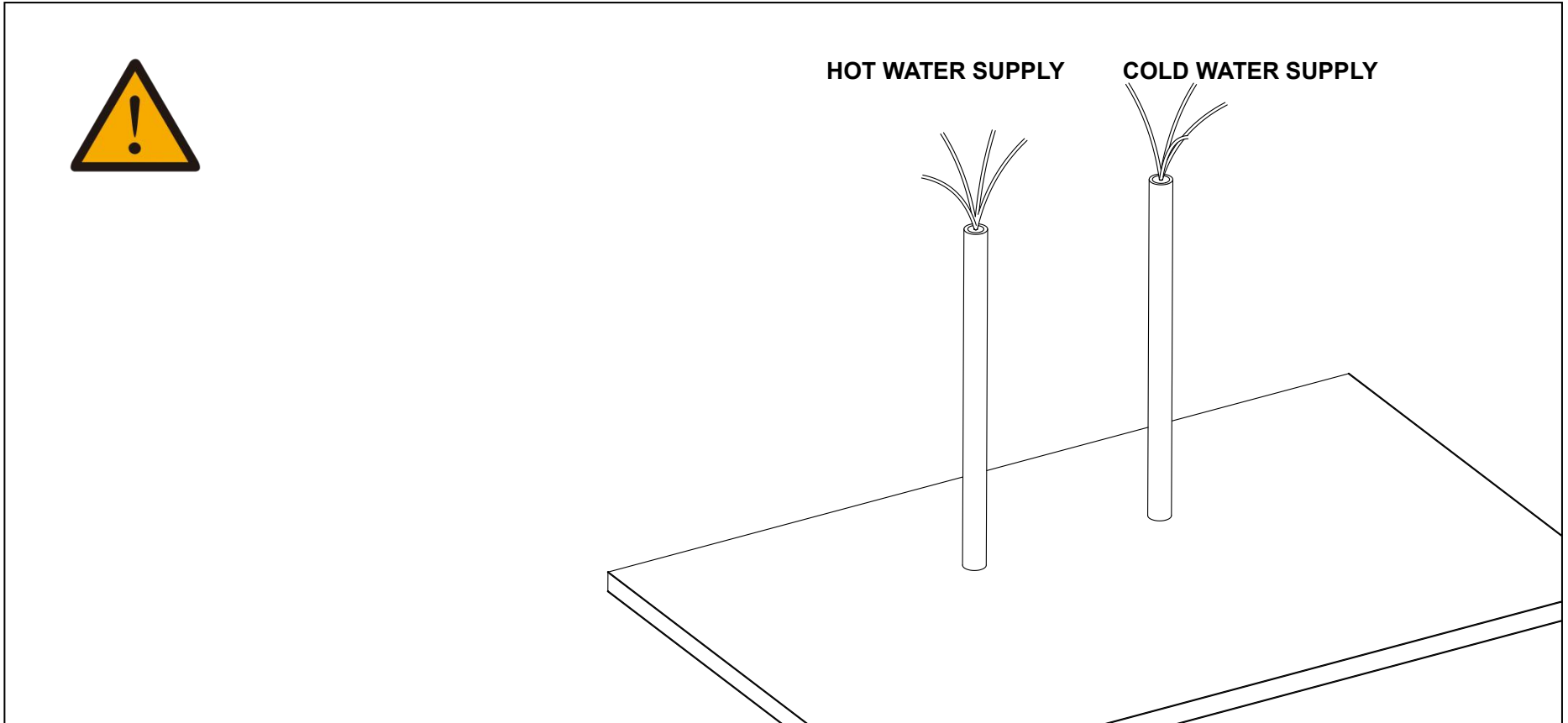

5.3 Use a spirit level to position and level the valve assembly. Mark the rough-in valve's mounting holes on the mounting rack.

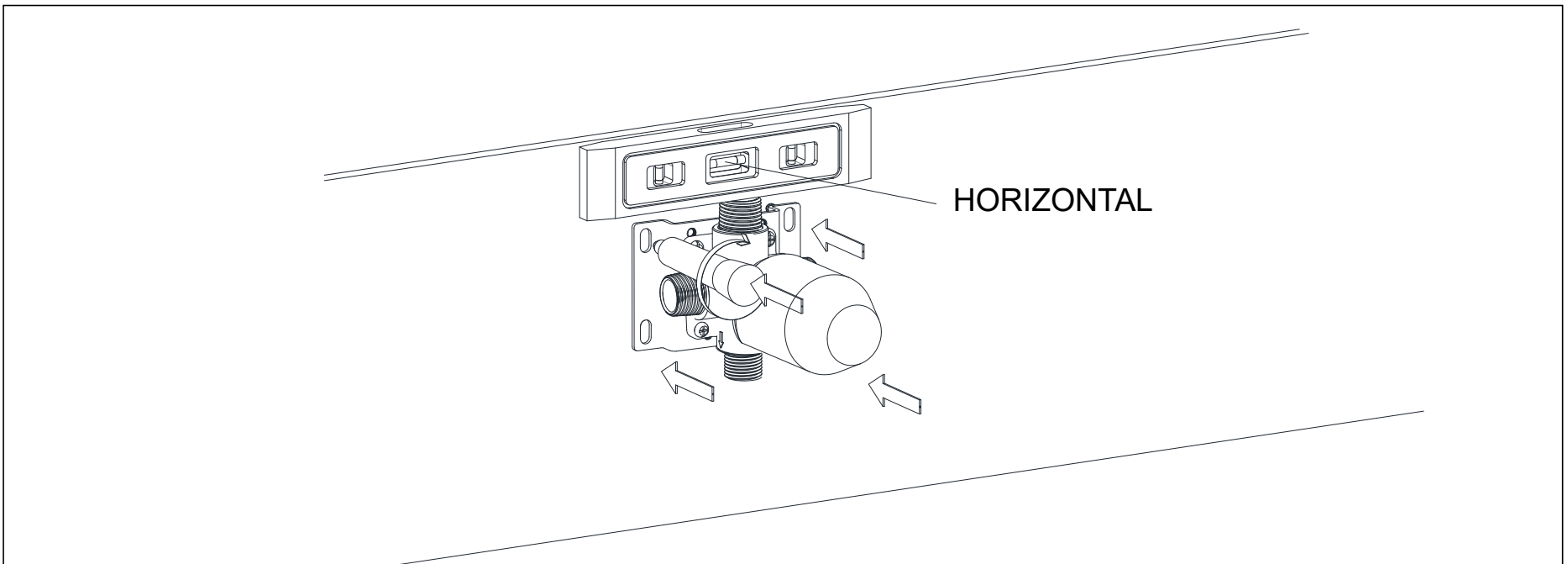

5.4 Connect the valve body to the water supply system using the appropriate fittings for your valve type (copper, iron, or PEX).

Note: For PEX, be sure to use the correct crimp fittings and proper cold expansion tool.

For copper tubing:

5.4.1(a) Remove the cartridge from the valve body before soldering.

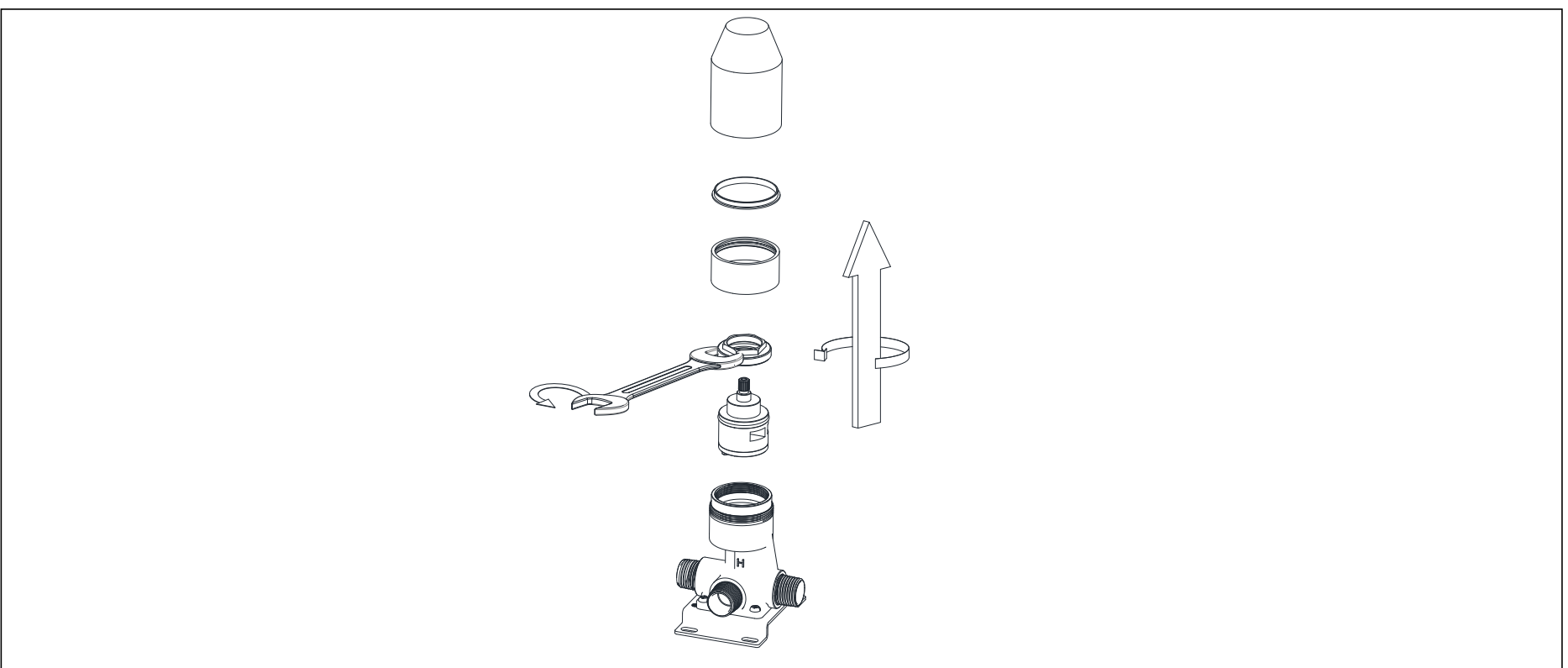

5.4.2(a) Solder copper pipes to the valve body's hot and cold water inlets, top shower outlet, and bottom outlet, then secure the plug. Note: The spout supports two installation methods—using a 5/8" Slip-on pipe or a 1/2" NPT male threaded fitting.

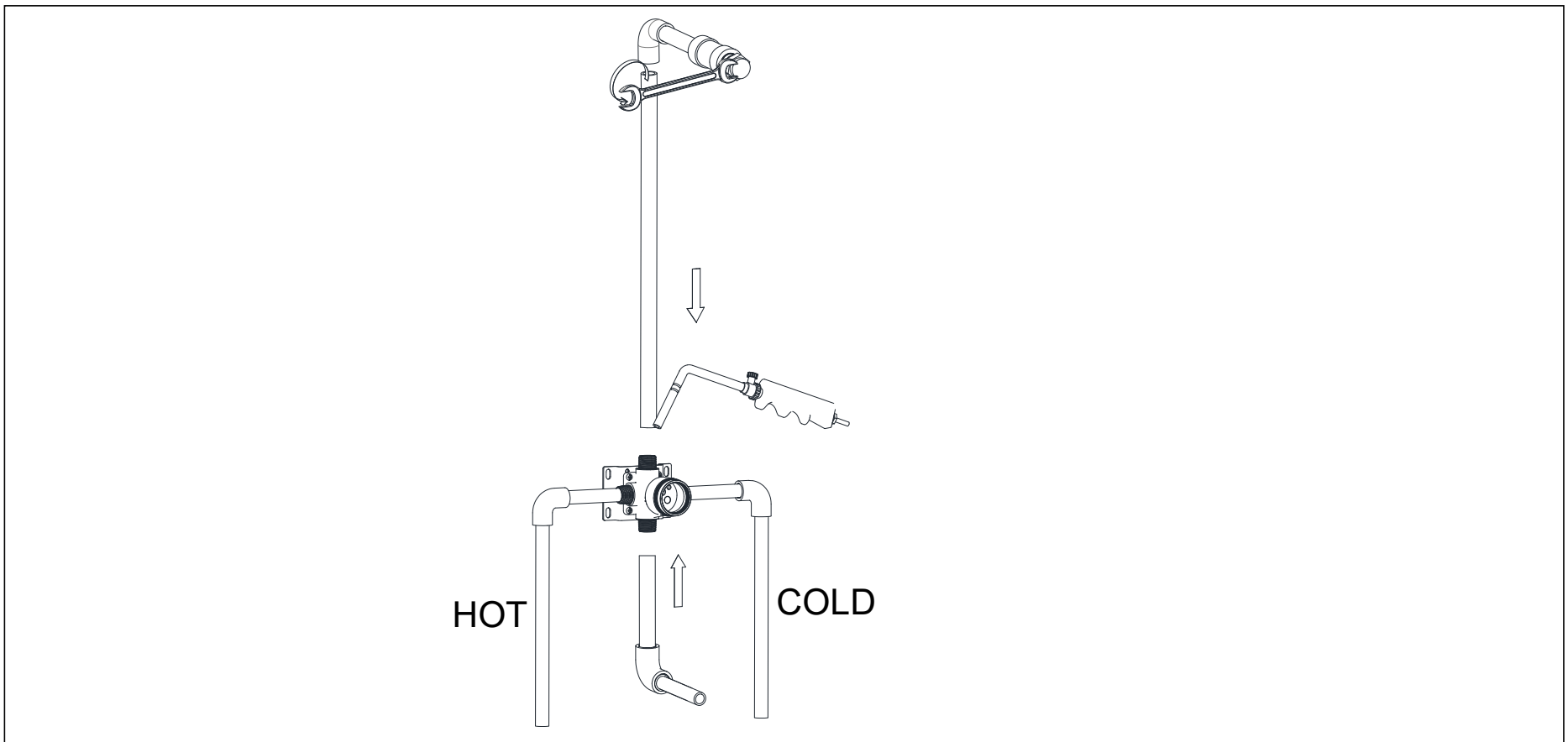
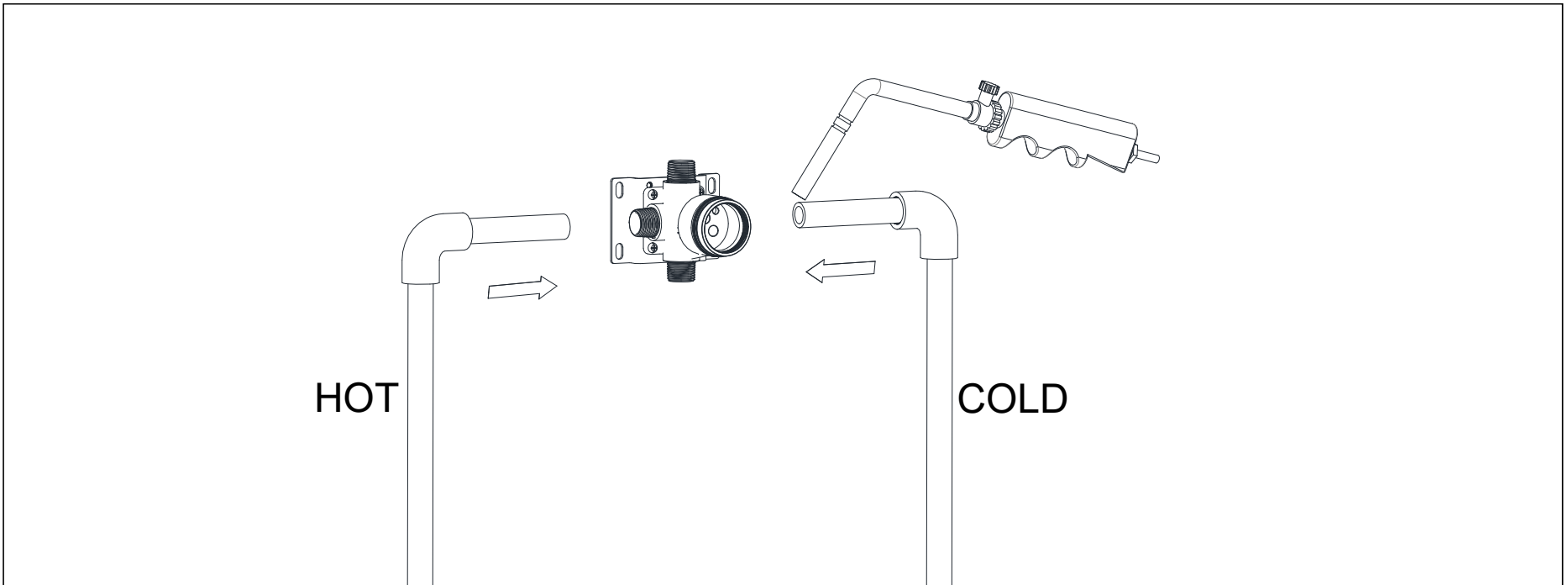

5.4.3(a) Reinstall the rough-in valve components.

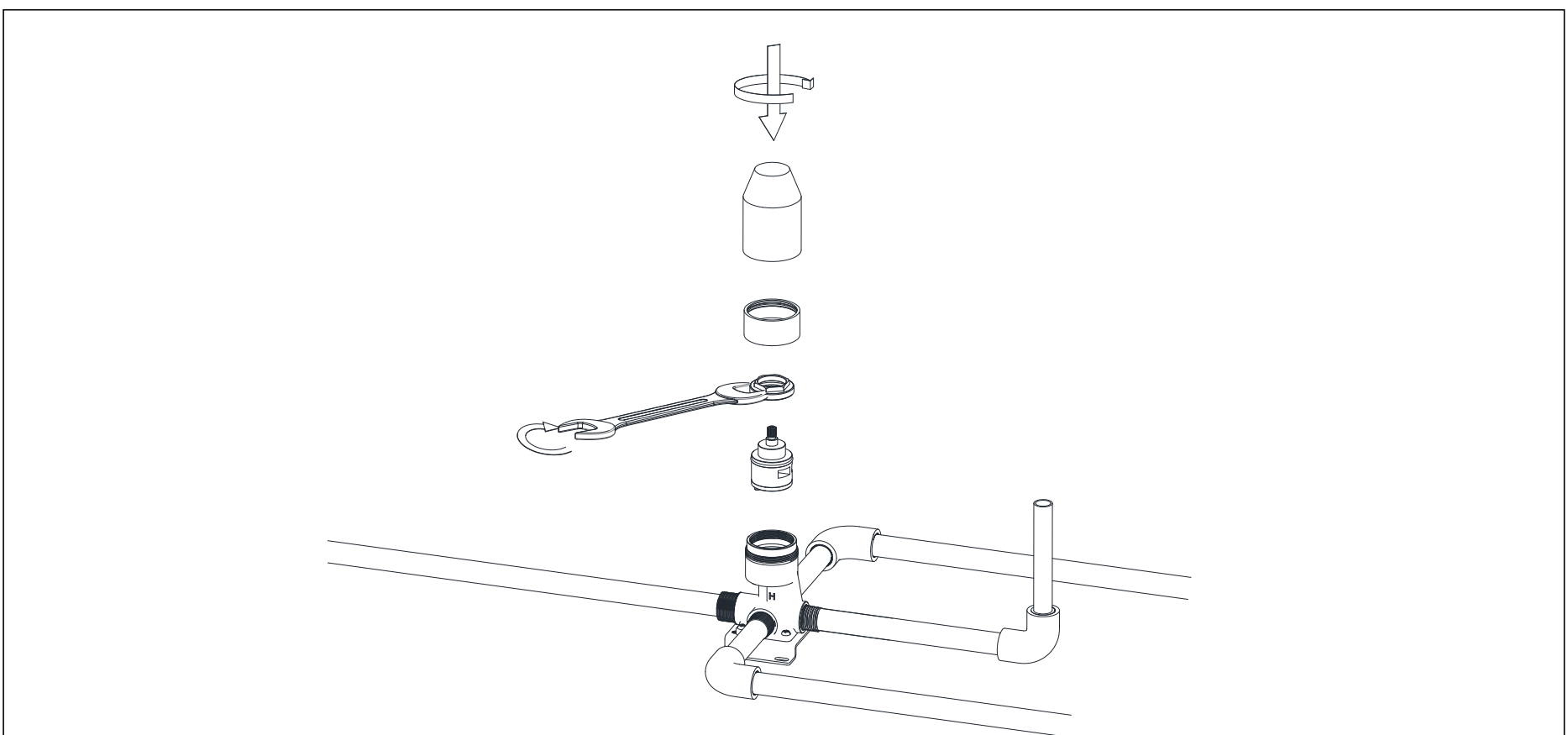

5.4.4 Align and level the valve assembly, then secure it to the mounting bracket using screws and anchors.

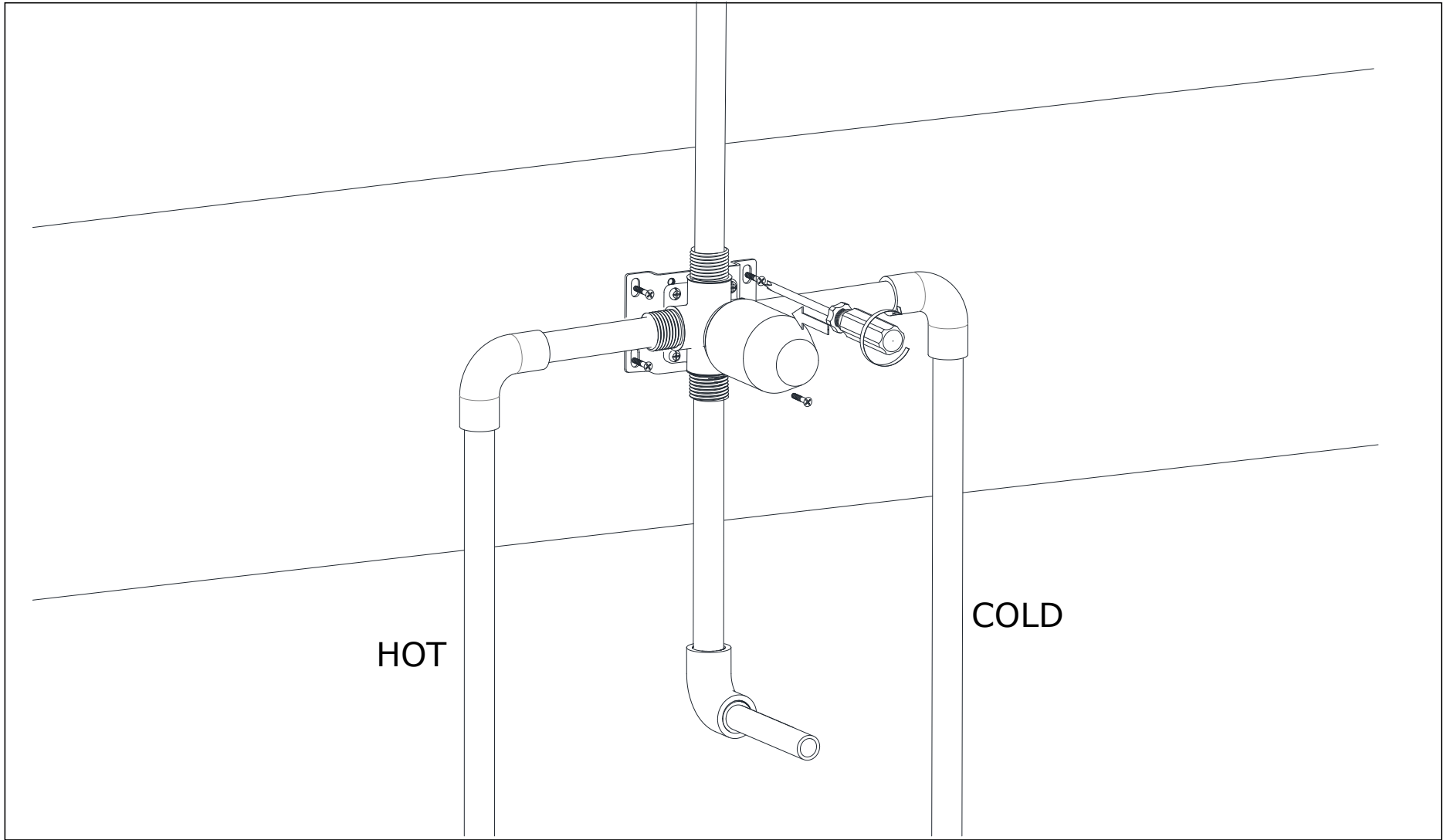

Align the elbow's front face with the finished wall.



Incorrect installation depth may cause connector leaks or require costly custom extension parts.

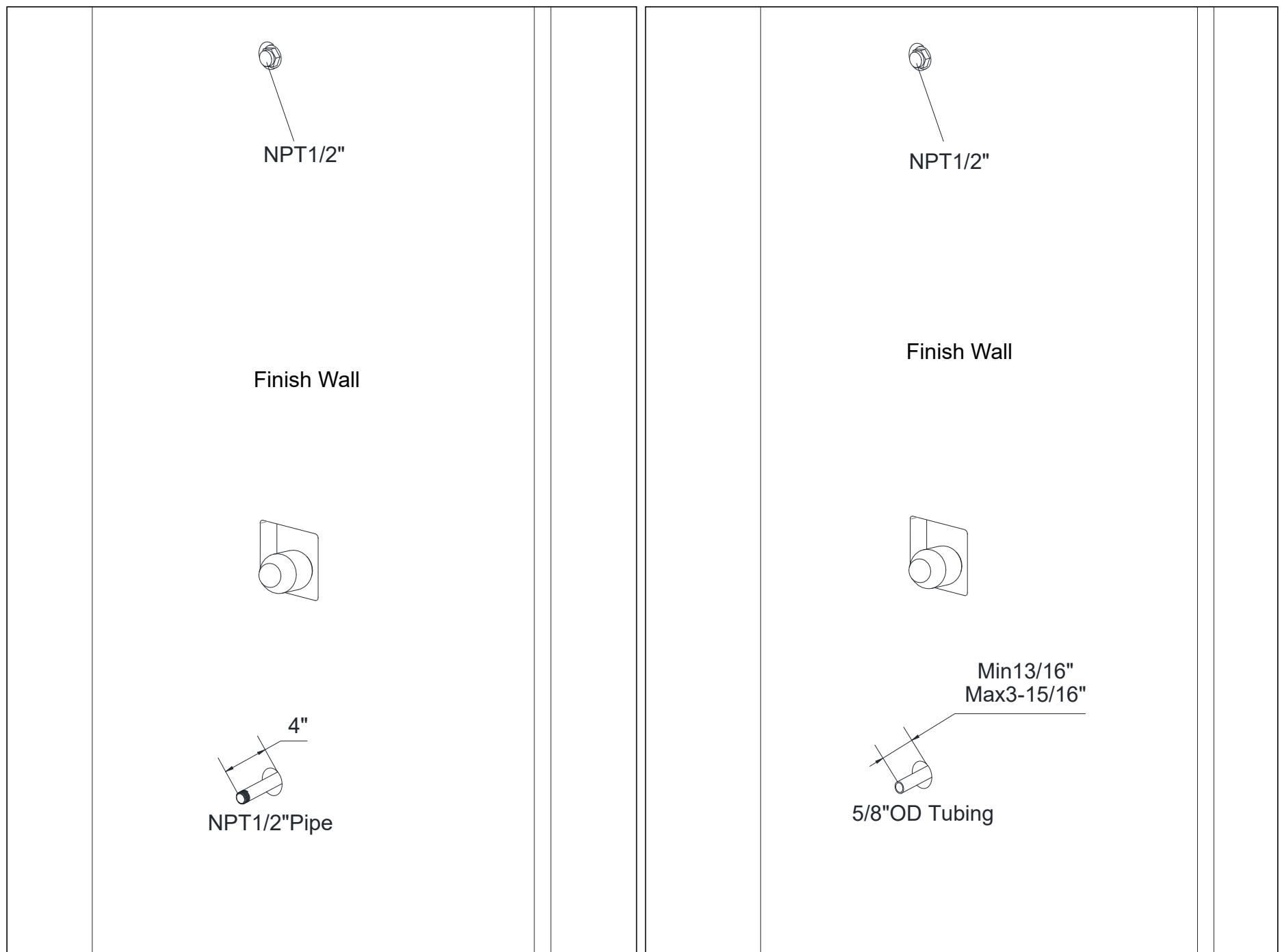

5.4.5 Skip steps 5.4.1(a) to 5.4.3(a) when using PEX or PVC fittings; disassembly is not required.
Apply Teflon tape to the valve body threads and connect the supply and shower pipes using PEX fittings (hot water on the left, cold water on the right).

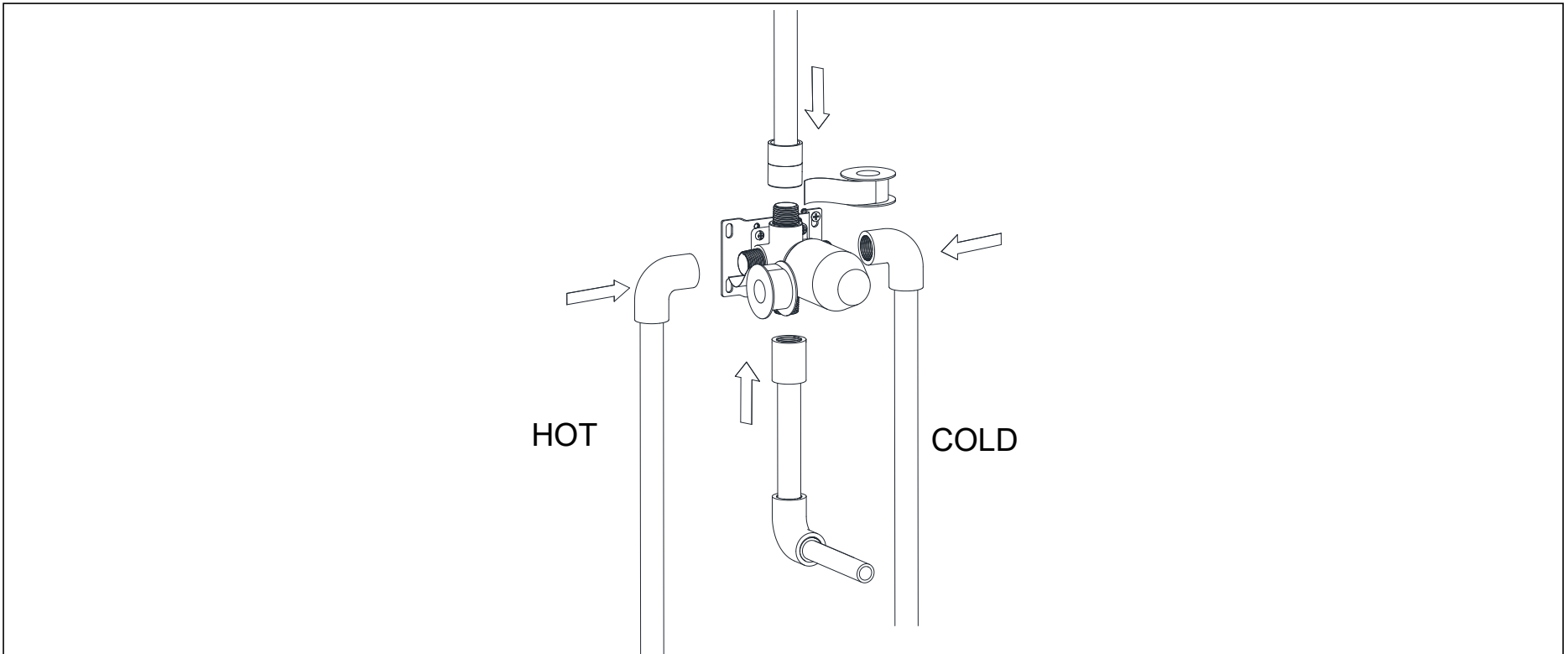

5.4.6 Rough-in valve installation is complete.

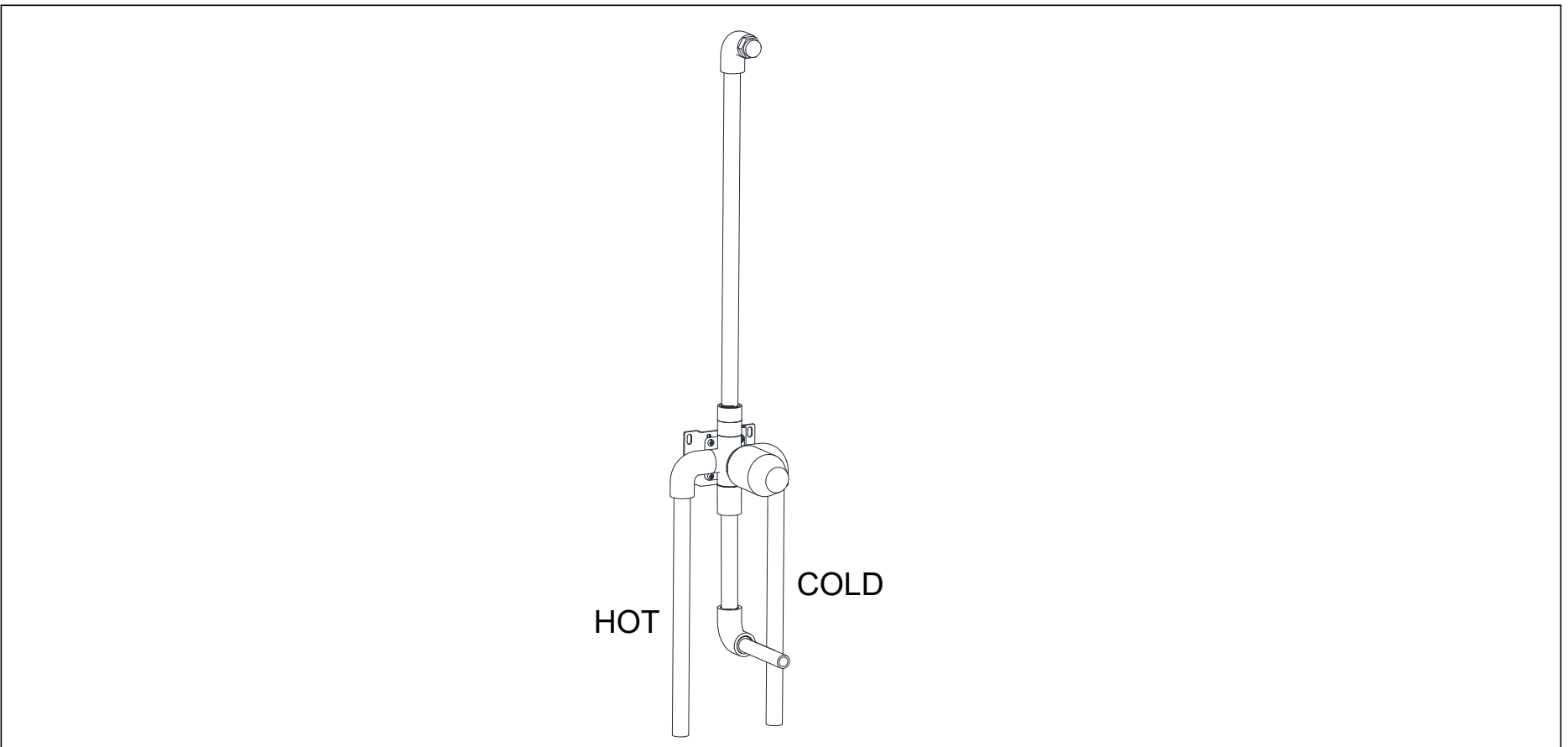

6. VALVE TRIM INSTALLATION

6.1 Remove the plaster guard cover.

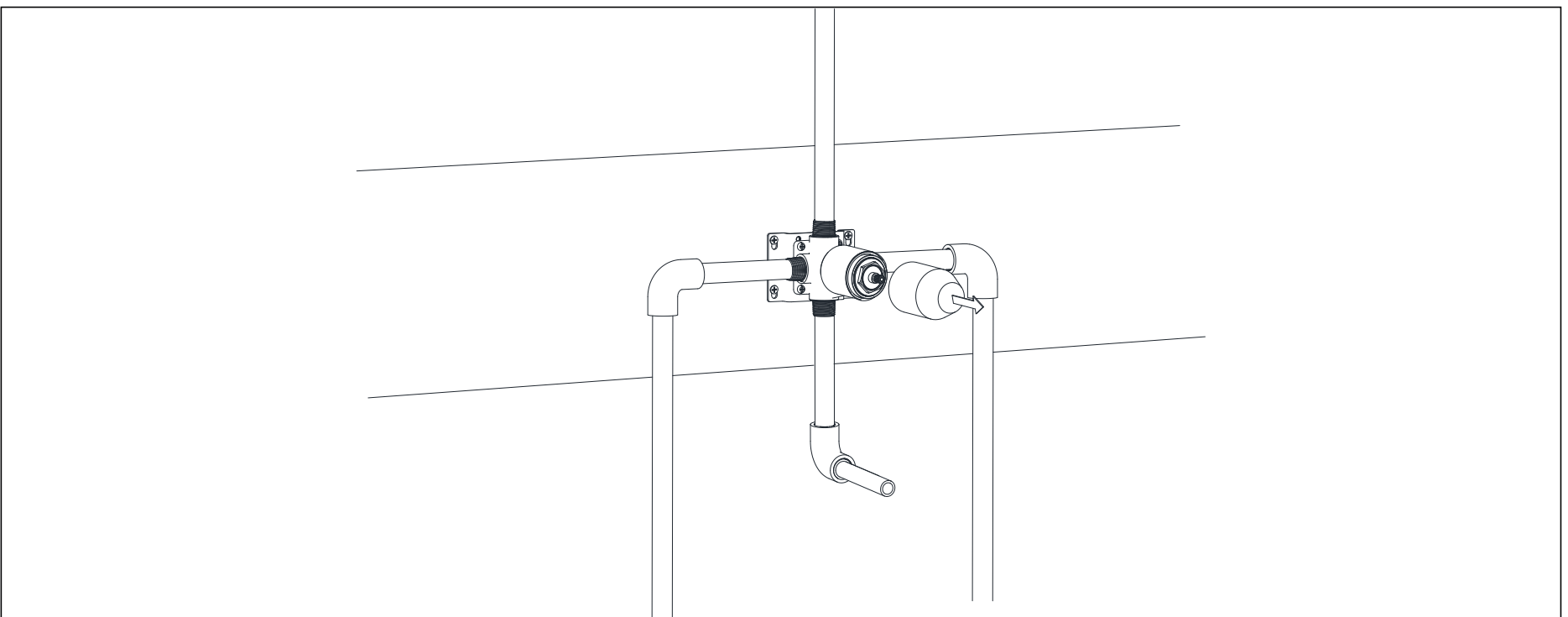

6.2 Plumbing Pressure Testing and Leak Testing.

(a.) Water Pressure Testing Standards

Test Pressure:

- The test pressure shall be 1.5 times the working pressure of the piping system, but not less than 60 PSI (pounds per square inch).
- If the design working pressure of the piping system is less than 60 PSI, the test pressure shall be 60 PSI.
- Recommended test pressure: 100 PSI to 120 PSI (approximately 6.9 to 8.2 bar).

Test Duration:

- The test duration is typically 15 minutes.
- During the test, the pressure should remain stable with no significant drop.

Testing Method:

1. Seal the piping system, ensuring all openings (e.g., faucets, valves) are closed.
2. Use a manual pump or pressure testing equipment to pressurize the system to the specified test pressure.
3. Observe the pressure gauge to ensure the pressure remains stable during the test.
4. Inspect all connections, joints, and faucets for any signs of leakage.

Pass Criteria:

- If the pressure remains stable with no significant drop and no leakage is observed during the test, the piping system passes the test.
- If the pressure drops or leakage is detected, repair the issue and retest.

Precautions:



- Safety: The test pressure should not exceed the rated pressure of the pipes and fittings to avoid damage.
- Record: Record the test pressure, duration, and results for future inspection or maintenance purposes.

(b.) Leak Testing: After completing the plumbing pressure test, turn on the hot and cold water supply again and check all connections for leaks. If no leaks are detected, shut off the hot and cold water supply and reinstall the plaster guard covers.

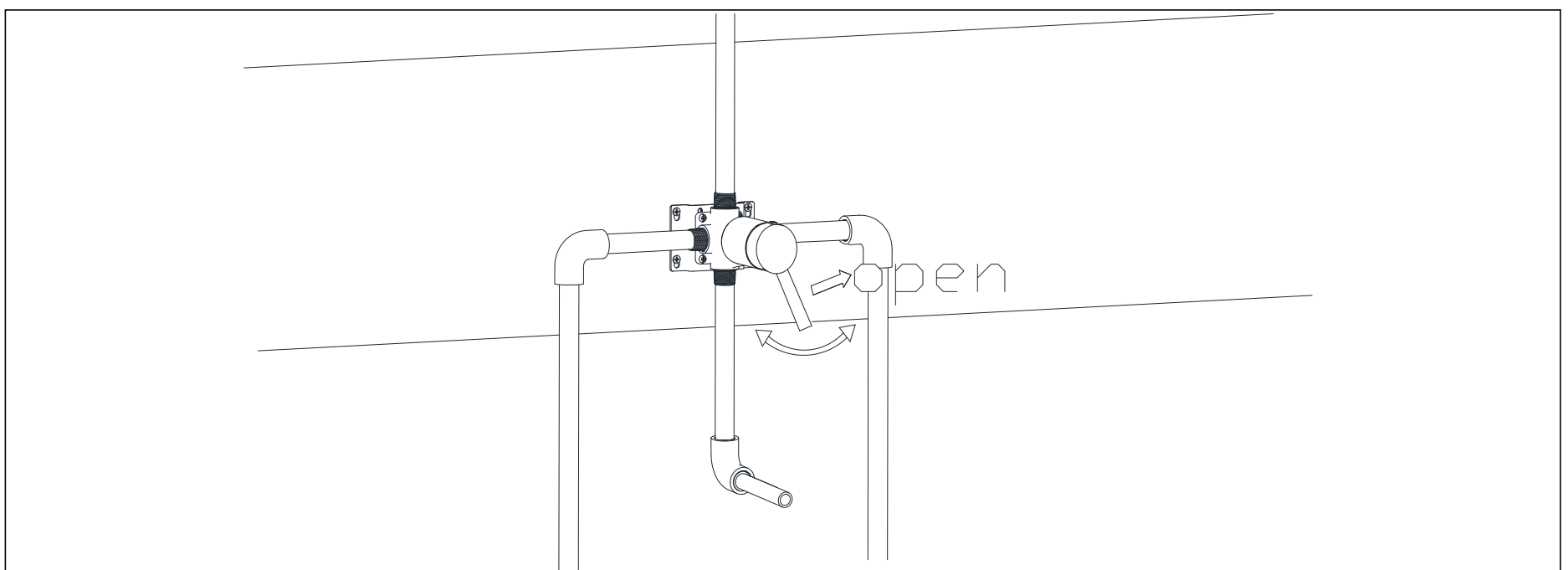

Precautions:



- Record: Record the test pressure, duration, and results for future inspection or maintenance purposes.

6.3 Complete the finished wall and create an access panel if future maintenance is needed.

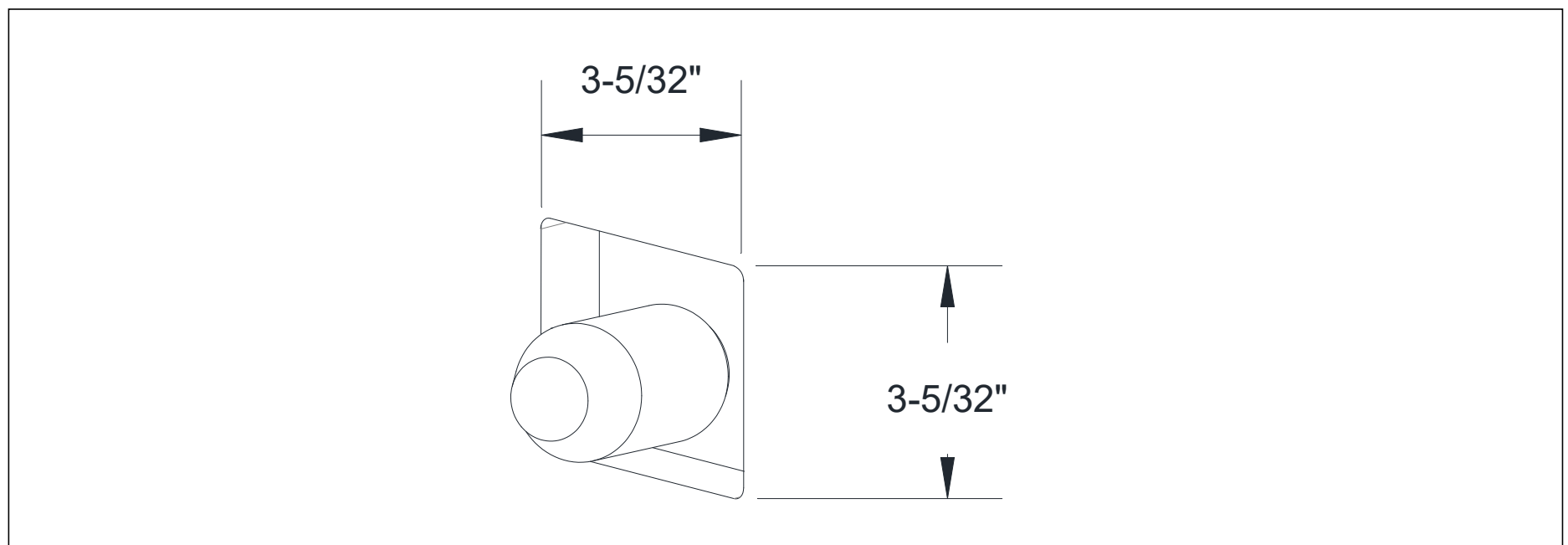

6.4 Install the escutcheon onto the valve body.

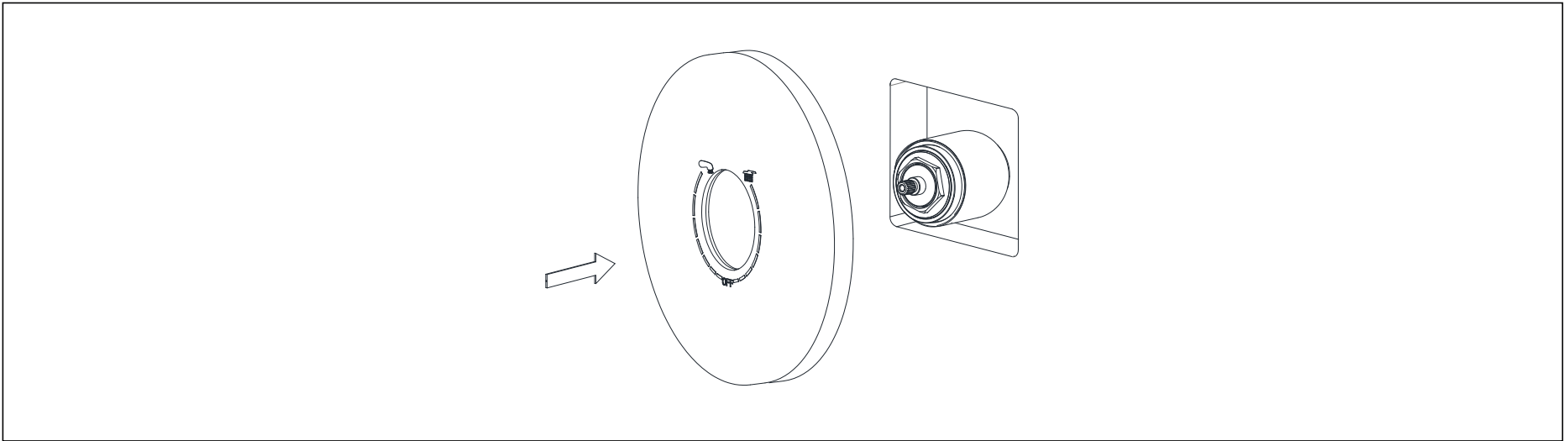

6.5 Ensure the valve stem is aligned with its markings. Attach the handle, tighten the set screw with the provided Allen wrench (do not overtighten), and press in the screw cover.

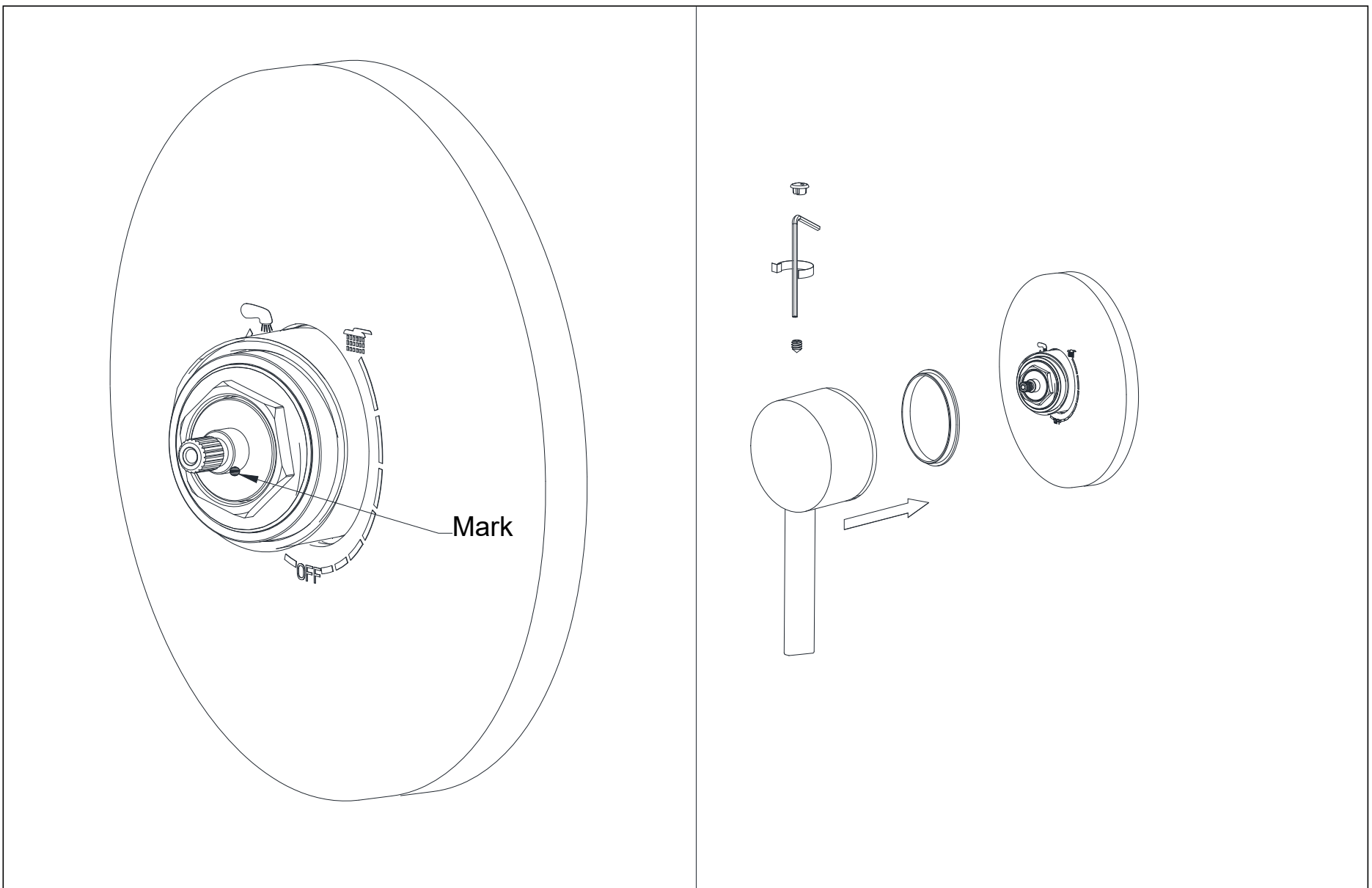

6.6 Valve trim installation is complete.

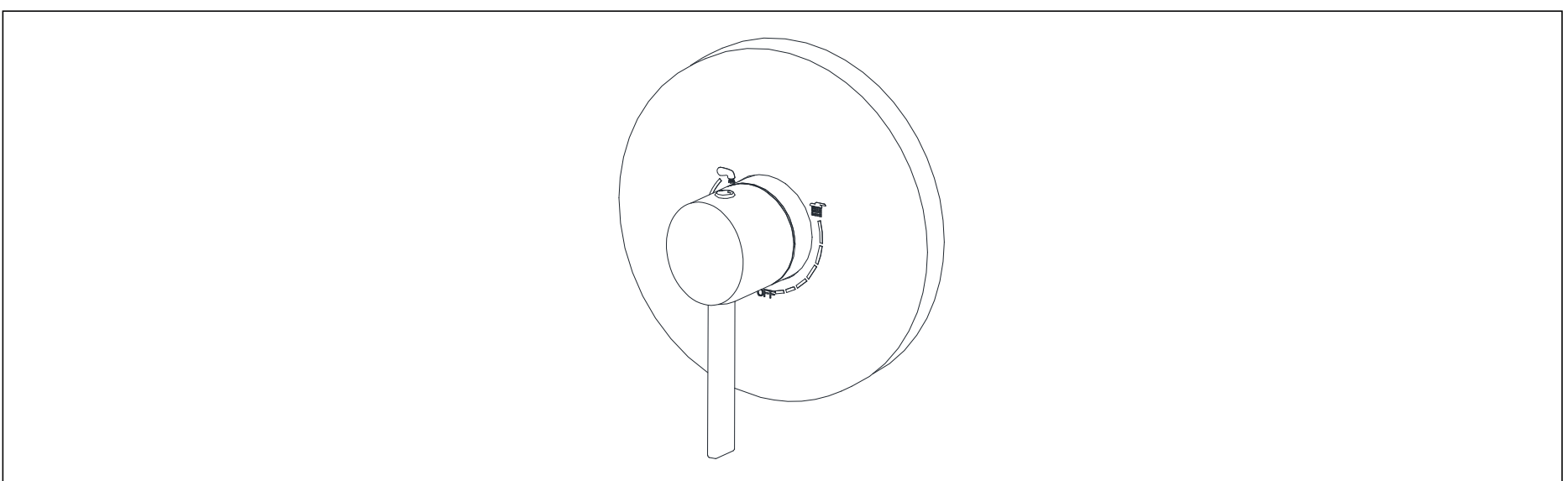

7. SHOWERHEAD INSTALLATION

7.1 Slide the escutcheon onto the shower arm and apply Teflon tape to the shower arm threads. Secure the shower arm to the wall pipe elbow by rotating clockwise.

Standard shower arm inlet thread: NPT 1/2" (US, CA)

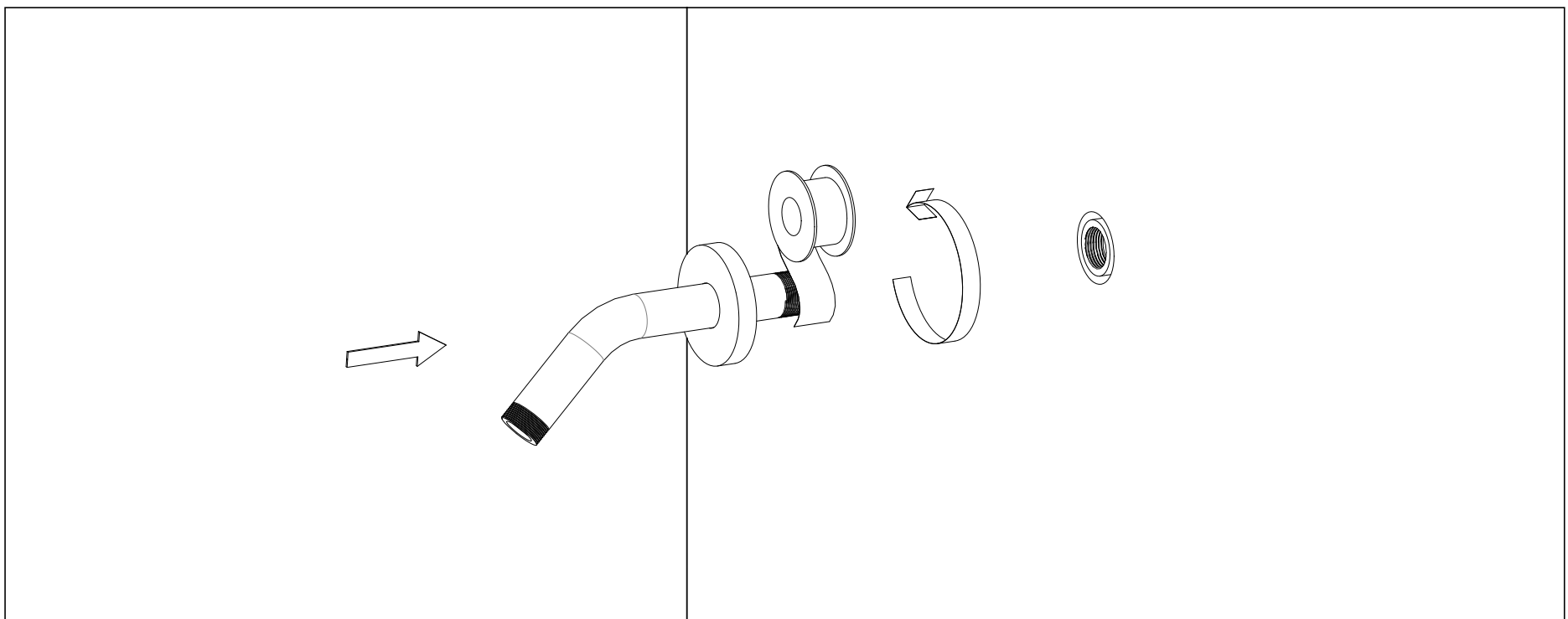
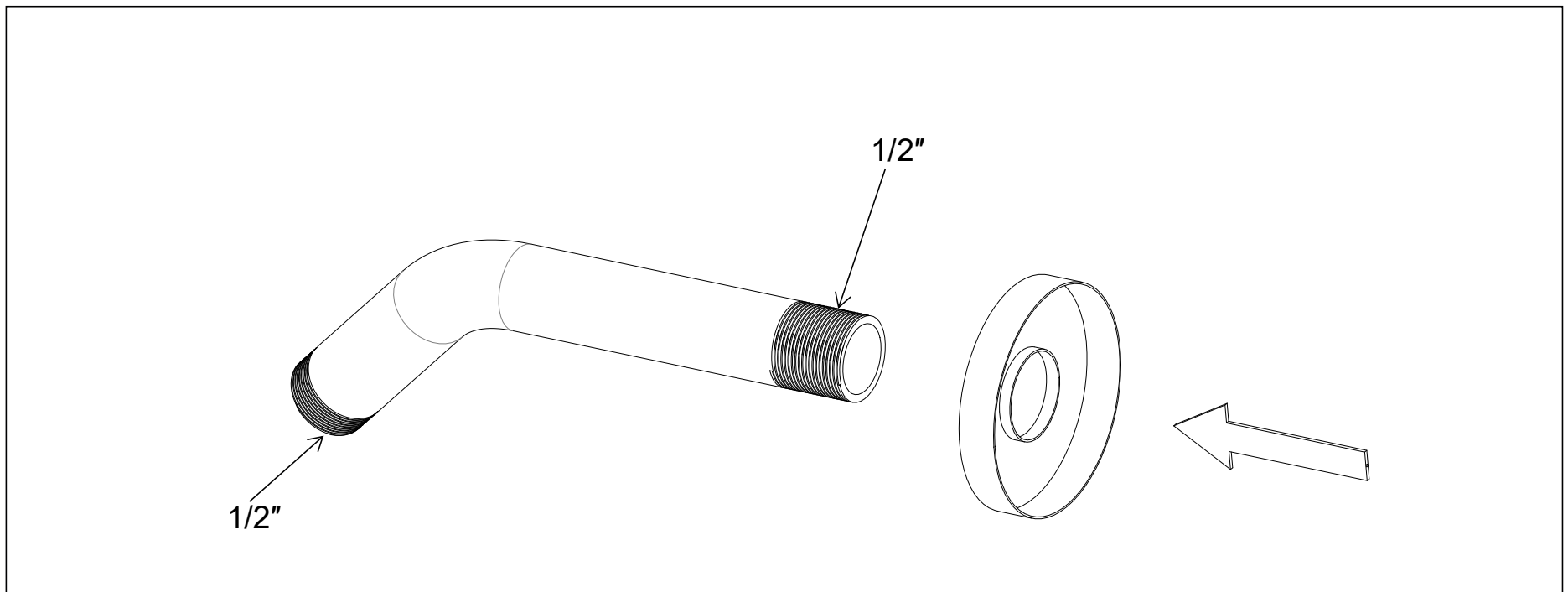

7.2 Apply waterproof sealant around the shower arm escutcheon to seal the wall.

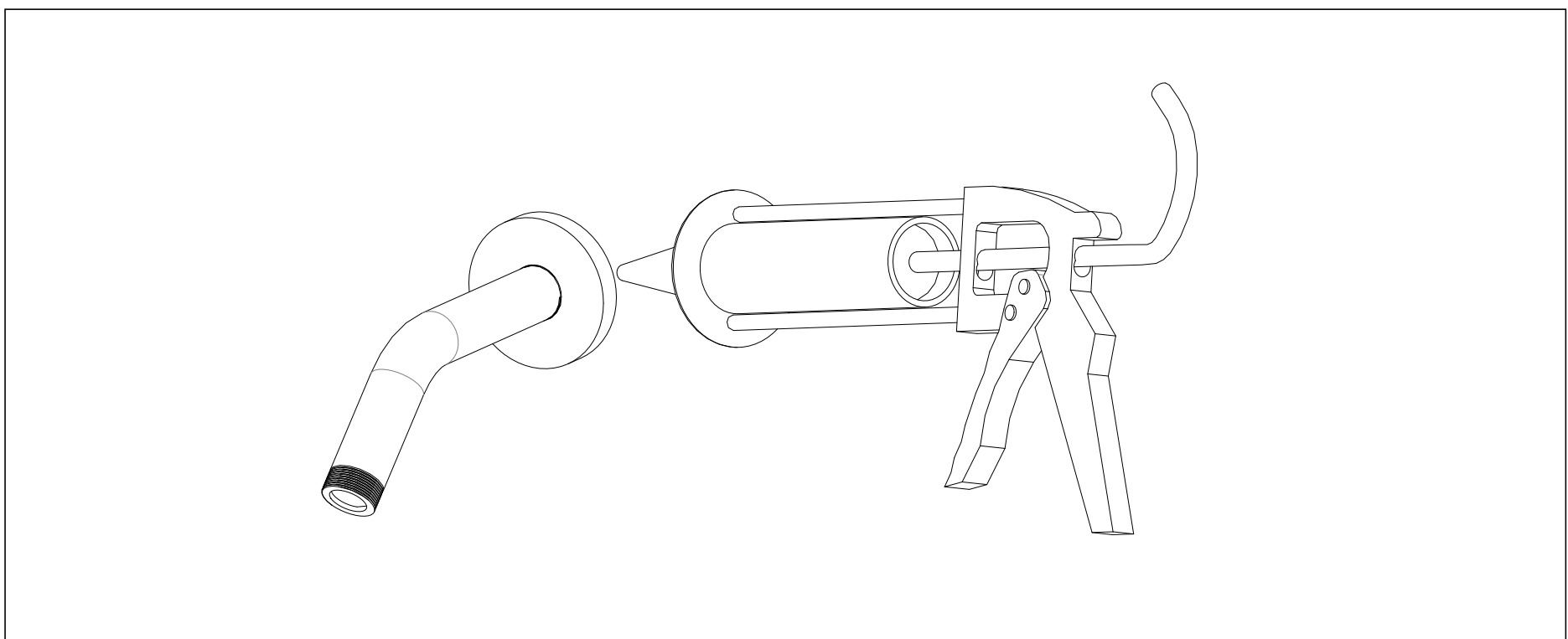

7.3 Put the screen washer into the hand shower holder and secure the hand shower holder on the shower arm by hand rotating clockwise.



Note: Missing the screen washer may result in improper shower function.

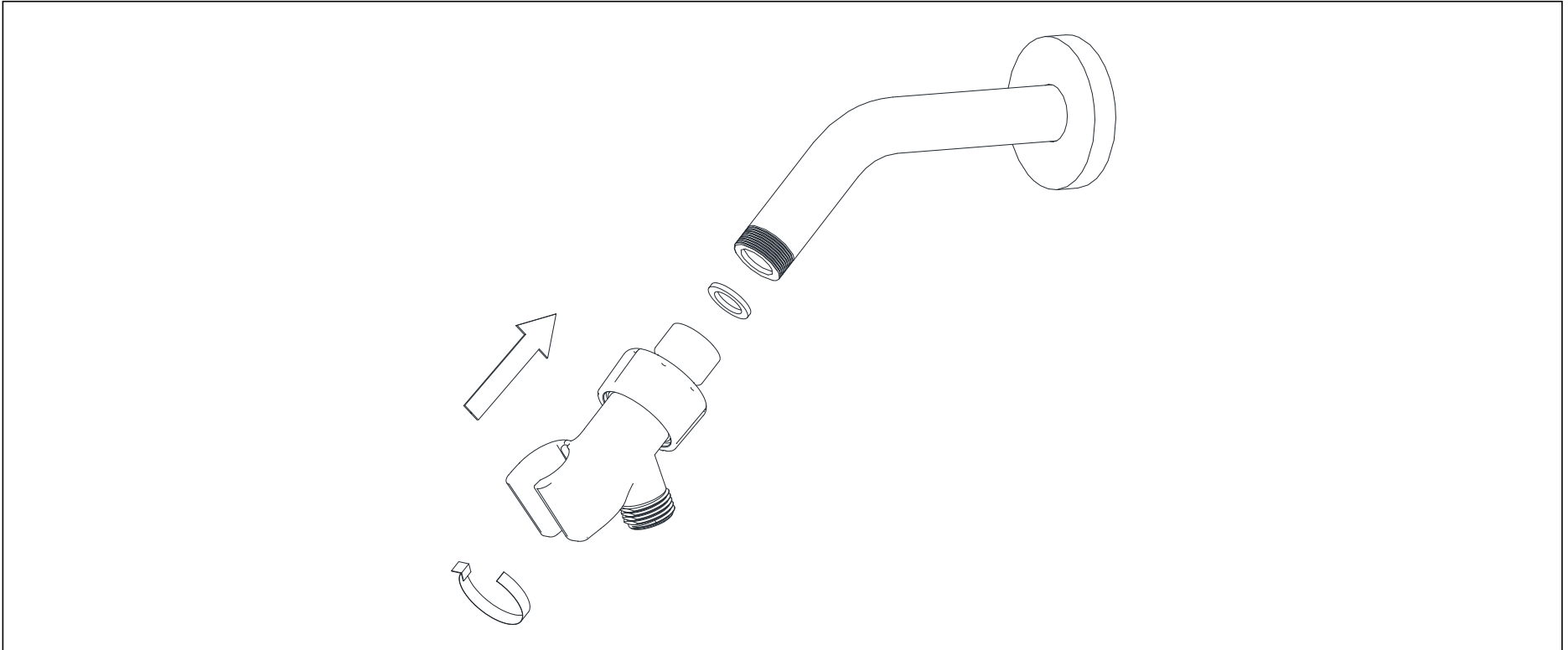

7.4 Connect the hand shower to the wall supply elbow with flexible hose.



Note: Missing the screen washer or check valve may result in improper shower function.

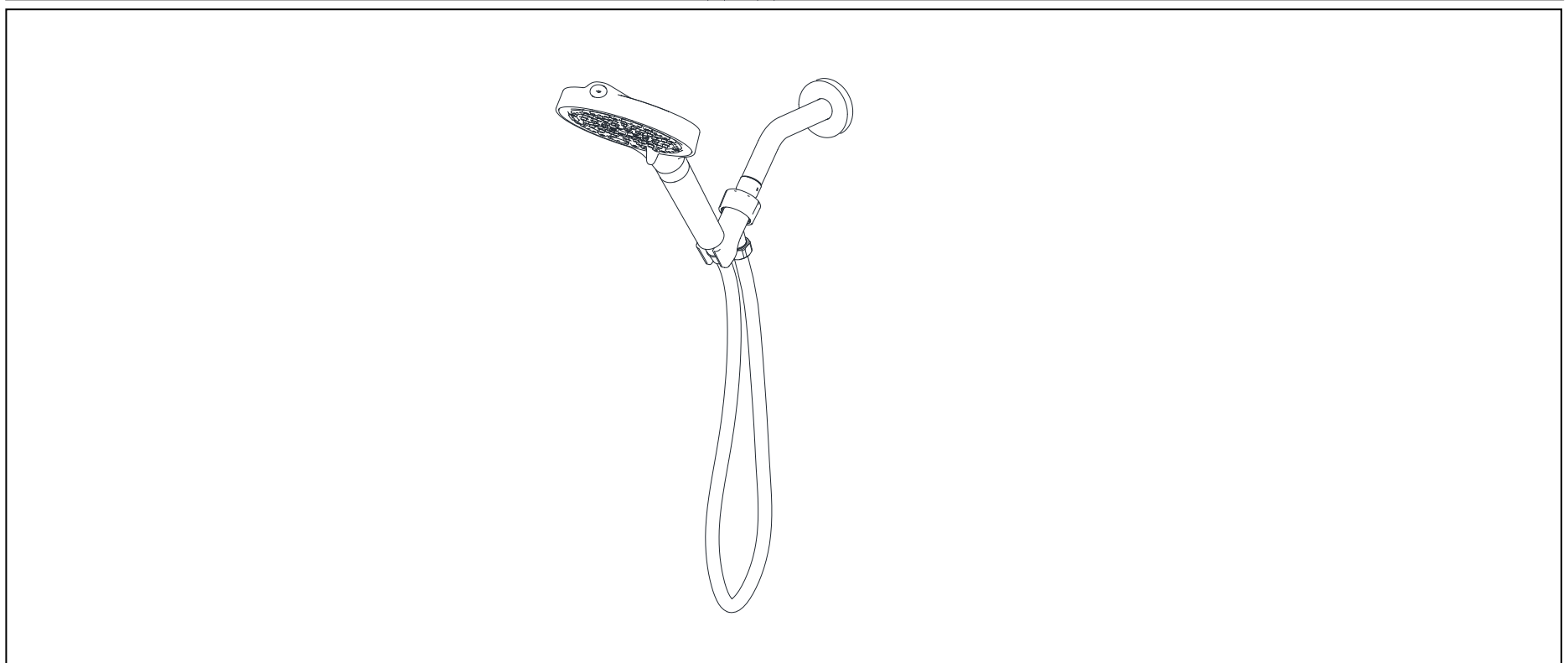
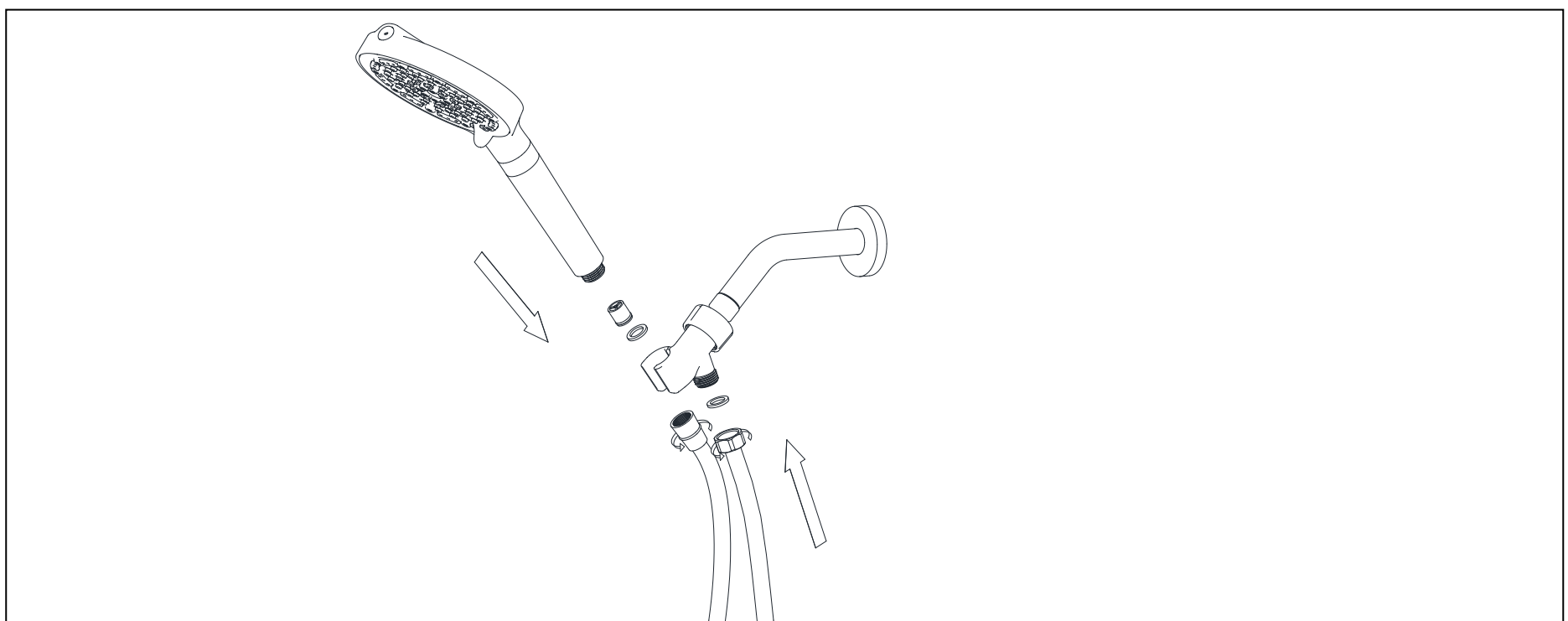

8. TUB SPOUT INSTALLATION

8.1(a) Install the Threaded Spout

 **NOTE:** The following instructions are for threaded spout.

Install a 1/2" NPT threaded pipe nipple to extend beyond the finished wall per specified dimensions. Apply plumber's tape to the threads. Hand-tighten the adapter onto the pipe nipple and secure it with a standard pipe wrench. Tighten firmly against the wall.

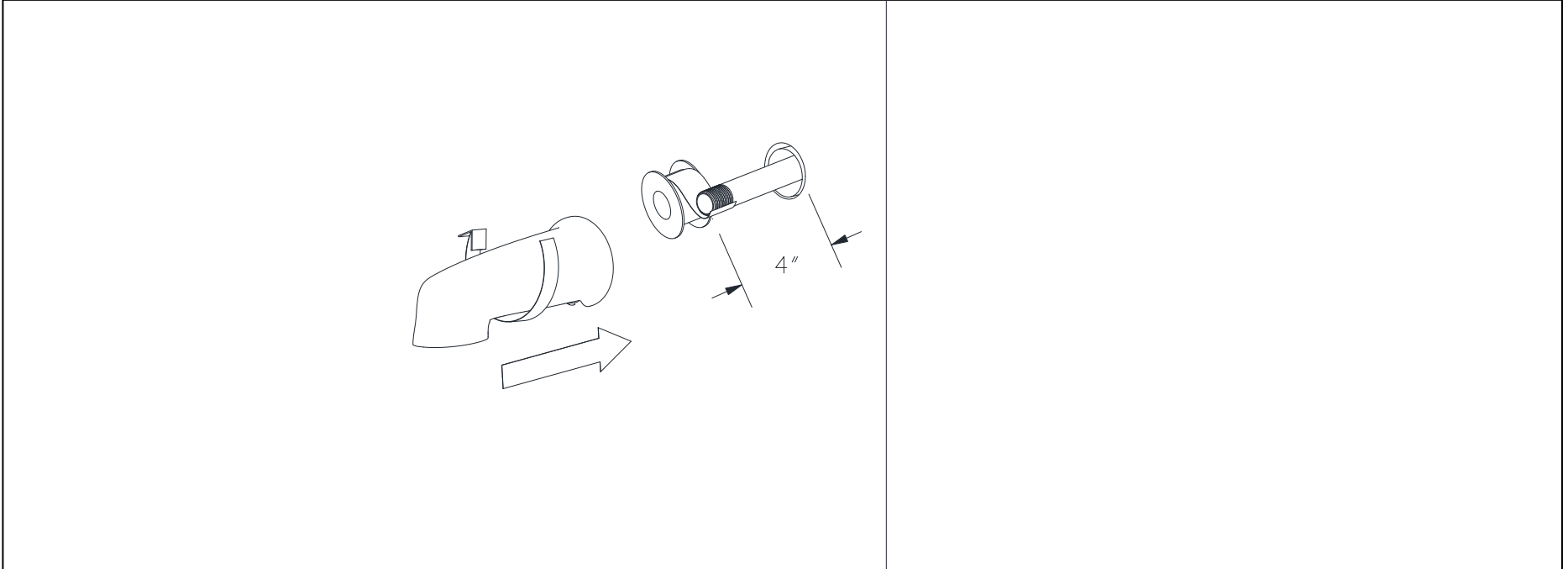

8.2(b) Install the Slip-Fit Spout:

Tub Spout Adapter remove from the Spout if the adapter is installed.

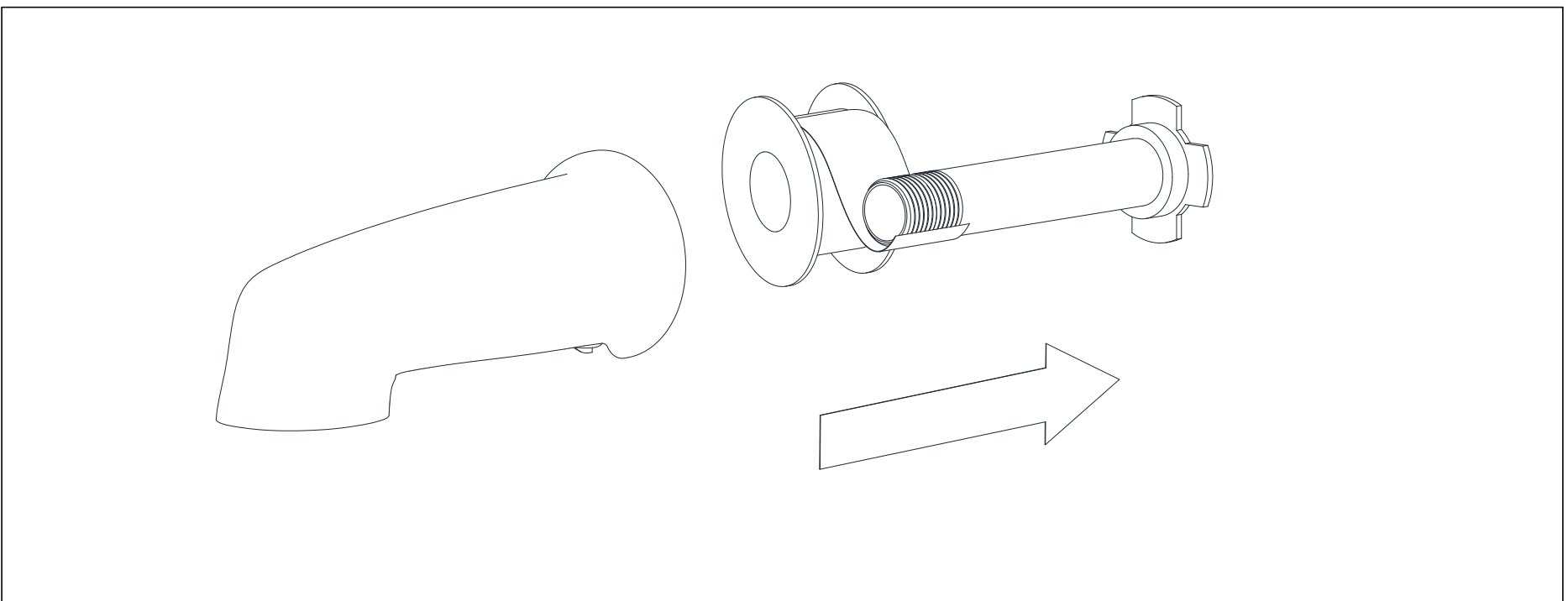

8.3 (b) Loosen the set screw halfway using an Allen wrench (do not fully remove the screw).

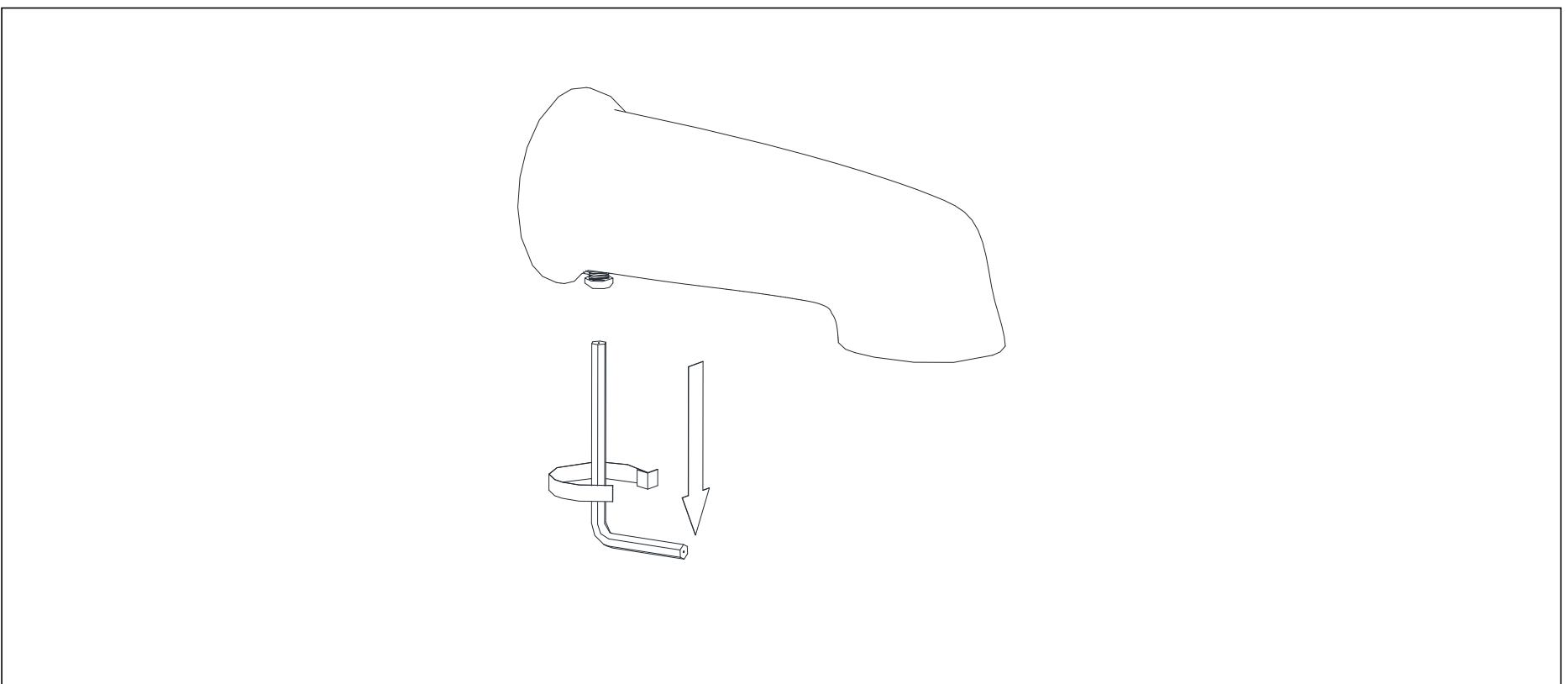

8.4(b) Smooth the outlet fitting edges with emery paper to remove any burrs. Slide the spout onto the outlet fitting and push the spout base flush against the finished wall.

Outlet fitting diameter: $\frac{5}{8}$ ". Extension length: minimum $\frac{13}{16}$ " to maximum $3-\frac{15}{16}$ " beyond the finished wall.

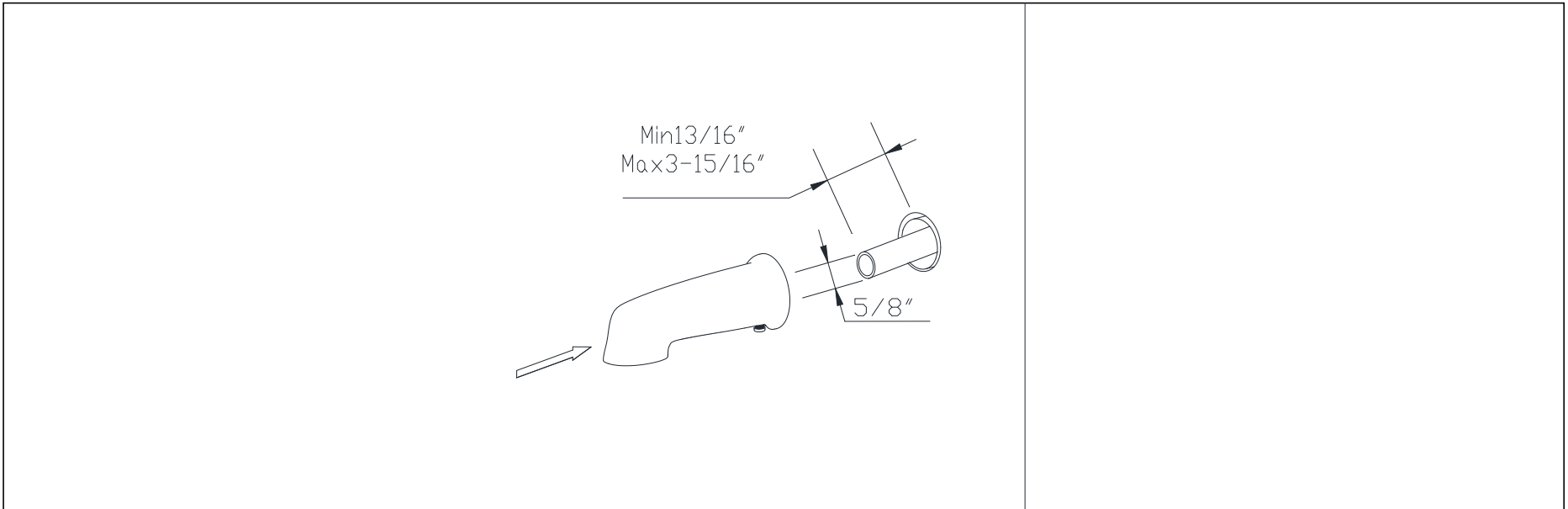

8.5(b) Adjust the spout direction and carefully tighten the set screw. Avoid overtightening.

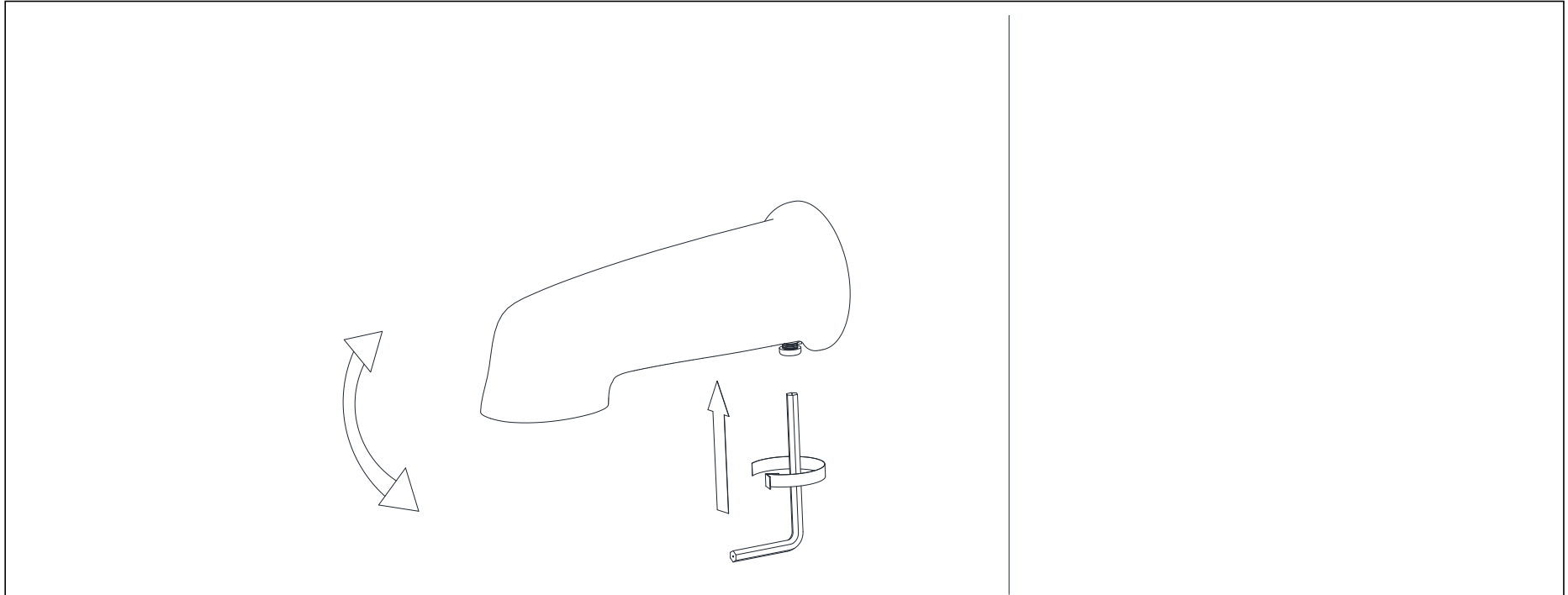

9. ASSEMBLY FINISHED.



10. INSPECTION

10.1 Turn on the hot and cold water supply and check all connections for leaks.

11.1 Adjusting the spray pattern of the handheld shower.

(a.) Select various water spray patterns:

The handheld shower is equipped with six different water spray modes to enhance your showering experience. These modes include:

- Rain
- Waterfalls and rain showers
- Waterfalls
- Waterfalls and Massage
- Massage
- Top Water Outlet: Rush Clean Spray

(b.) How to switch to Rush Clean Outlet:

Locate the spray mode selector: locate the spray mode selector on the handheld shower.

To change mode:

- (1) Rotate the spray mode selector to the left or right to switch between different spray patterns.
- (2) You will feel a slight click when you turn the spray mode selector to the new position.

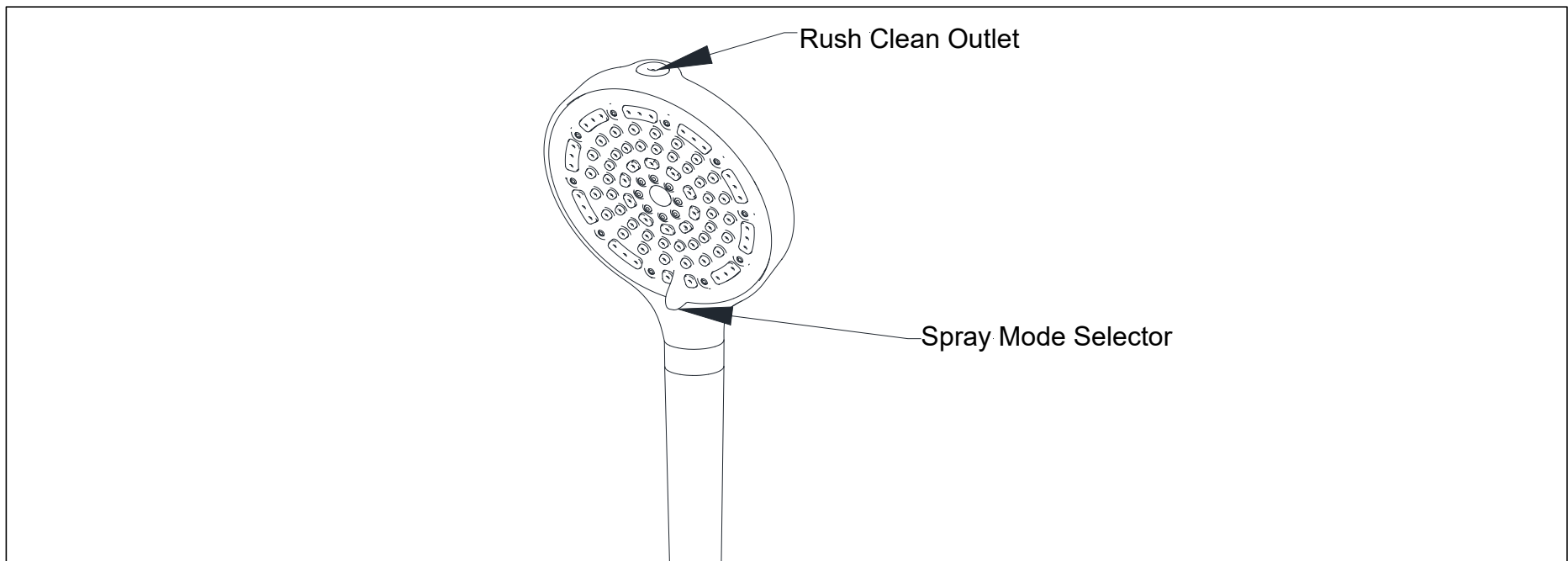

11.2 Handheld Shower Usage Guidelines:

(1) This showerhead comes standard with an anti-scale filter element. The anti-scale filter element is an optional accessory, allowing users to choose whether to install it based on their specific needs.

(2) Each anti-scale filter element is normally effective for three months or can treat up to 3 tons of hard water. Once either condition is met, the anti-scale filter element must be replaced to restore its functionality.

Replace the Filter as follows:

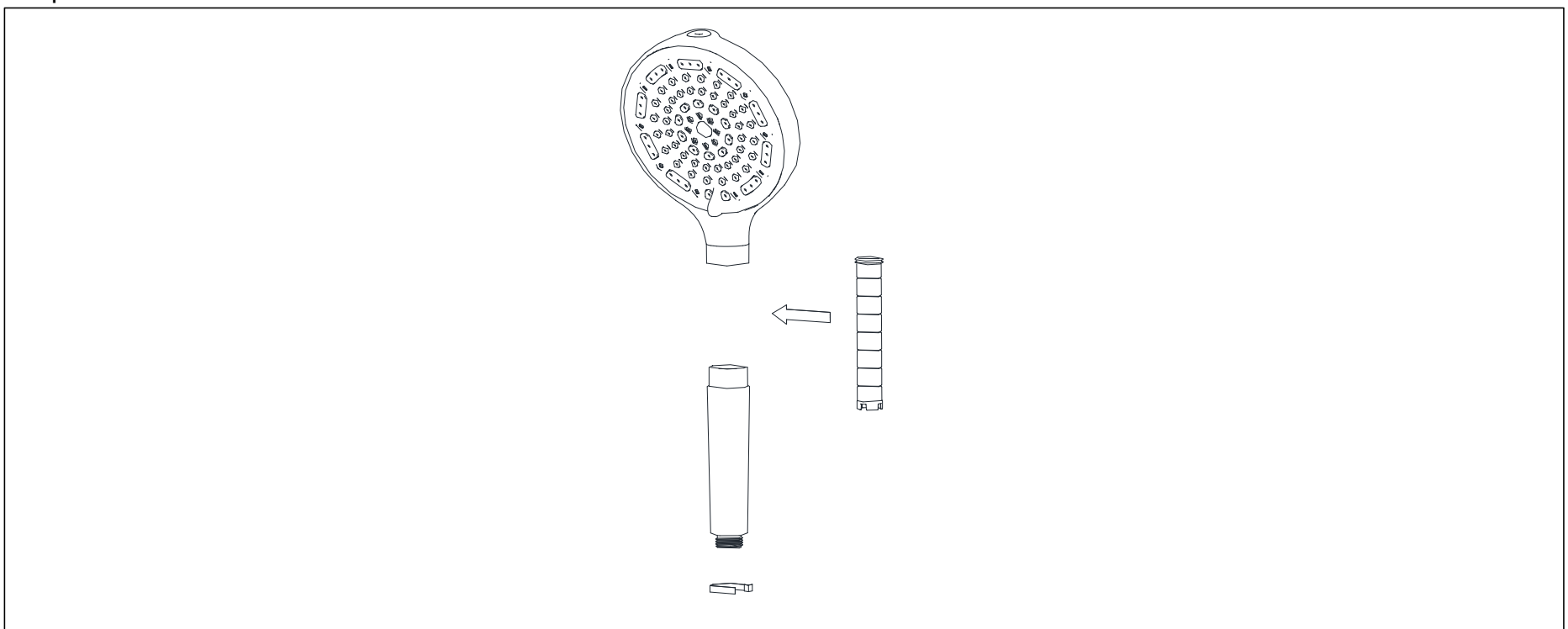

12. FUNCTION INSPECTION

12.1 Clockwise rotation of the handle activates water supply to the spout.

12.2 Counterclockwise rotation of the handle directs water flow to the handheld shower.

12.3 Mid-position (vertical handle alignment) shuts off all water supply.

INSTALLATION FINISHED

CLEARNING RECOMMENDATION FOR SUMERAIN PRODUCTS

Modern lavatory faucets, kitchen faucets, and showers are built using a wide variety of materials to cater to the market's demands for design and functionality. To avoid damage and potential returns, adhering to specific cleaning guidelines is crucial.

Cleaning Materials for faucets & showers

When cleaning faucets and showers, it is important to consider the following professional terms:

- Acidic cleaning agents are essential for lime removal.
- Ensure to use only cleaning agents that are specifically designed for this particular application.
- Avoid using cleaning agents containing hydrochloric, formic, phosphoric, or acetic acid, as they can cause significant damage.
- Avoid mixing different cleaning agents, as this can cause harmful chemical reactions.
- Avoid using abrasive cleaning agents or tools, including unsuitable cleaning powders, sponge pads, or microfiber cloths that could damage the surface.

Cleaning instructions for faucets & showers

Please follow the cleaning material manufacturer's instructions. In addition, pay attention to the following points:

- Clean faucets and showers regularly as needed to maintain their optimal function and appearance.
- Apply the recommended amount of cleaning product for the specified duration. Be sure not to leave the cleaner on the faucets longer than necessary to avoid potential damage.
- Regular cleaning can help prevent calcification. If you notice scale deposits on the faucet surface or spout, use a commercial descaler such as Lime-Away® or CLR®.
- In case of rust formation due to hard water conditions, gently abrade the affected area with aluminum foil soaked in water until the surface is smooth. Subsequently, apply a modest amount of chrome polish or a suitable product like automotive wax (for instance, Meguiar's®, Turtle Wax®) to buff the surface.
- Solid stainless steel faucets and spouts, especially waterfall spouts, typically lack a protective coating. Although stainless steel is naturally resistant to tarnishing, it can oxidize over time and react to its environment. Therefore, it's crucial to keep stainless fixtures clean and dry. Use a cleaner specifically designed for stainless steel, such as Weiman® or CLR®.
- When using a spray cleaner, it is recommended that you first apply it to a soft cloth or sponge rather than spraying it directly onto the faucet. This method helps prevent water droplets from entering the faucet opening and causing potential damage.
- After cleaning, thoroughly rinse with clean water to remove any residue from the cleaner.

Important

Residues from liquid soap, shampoo, and shower gel can also contribute to damage. Therefore, it's crucial to thoroughly rinse these substances off with clean water after use.



Note: if the surface is already damaged, the application of cleaning materials might exacerbate the damage.

Components with damaged surfaces must be replaced or injury could result.

Note that any damage resulting from improper treatment is not covered by the warranty.

SUMERAIN®

SUMERAIN INTERNATIONAL GROUP INC

Address: 1226 NORTH KING ST NUM 522
WILMINGTON, DE 19801
United States

Tel: +1(866)203-0866

Web: <http://www.sumerain.com>

E-mail: supports@sumerain.us

HONGKONG SUMERAIN SANITARY INDUSTRY CO., LIMITED

Address: FLAT/RM 3B 3/F BANK TOWER
NOS.351&353 KING'S ROAD
NORTH POINT
HK

Tel: +86-750-2731579

E-mail: supports@sumerain.com

SUMERAIN EUROPE SUPPORT

Address: Flottwellstr.15
10785 Berlin,
Deutschland

Tel: +49 (0)30/23975898

E-mail: de@sumerain.com