

# Installation Instruction

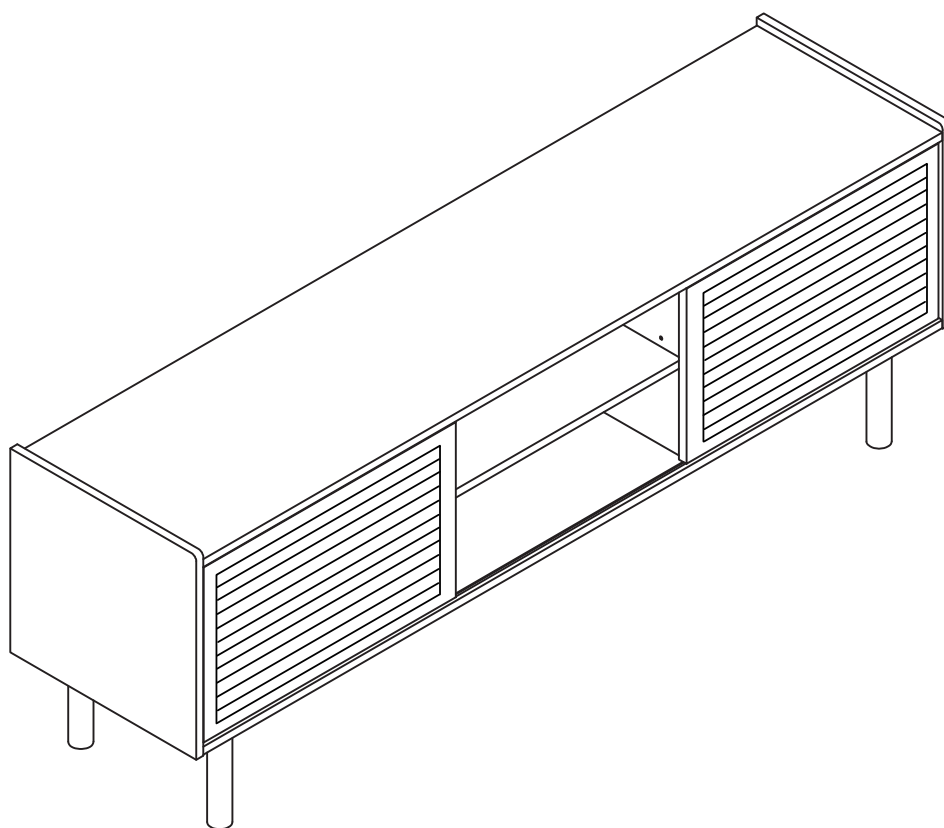

# Assembling

Estimated time for assembly



**45 : 00**

## What you need

- Use the packaging carton as a working surface to prevent product damage during assembly
- Phillips head screwdriver

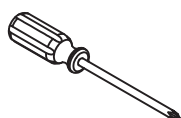

## Weight Limitation

 **100** | **35**  
lbs table top      lbs per

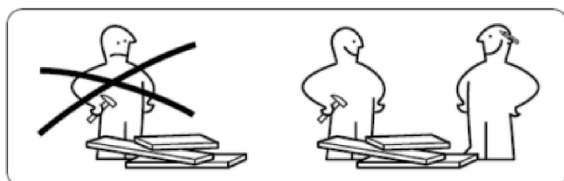

# What' included

Code	Description	Qty
A	Cam Bolt M6X35MM	12
B	Cam Lock 15X12MM	12
C	Wooden Dowel M6X30MM	24
D	Screw M4X40MM	4
E	The screw M6X40MM	10
F	The screw M6X55MM	4
G	Screw M3.5X16MM	26
H	Metal handle	4
I	Guide wheel	8
J	The screw M4X55MM	1
K	The back button	10

# The Hardwares

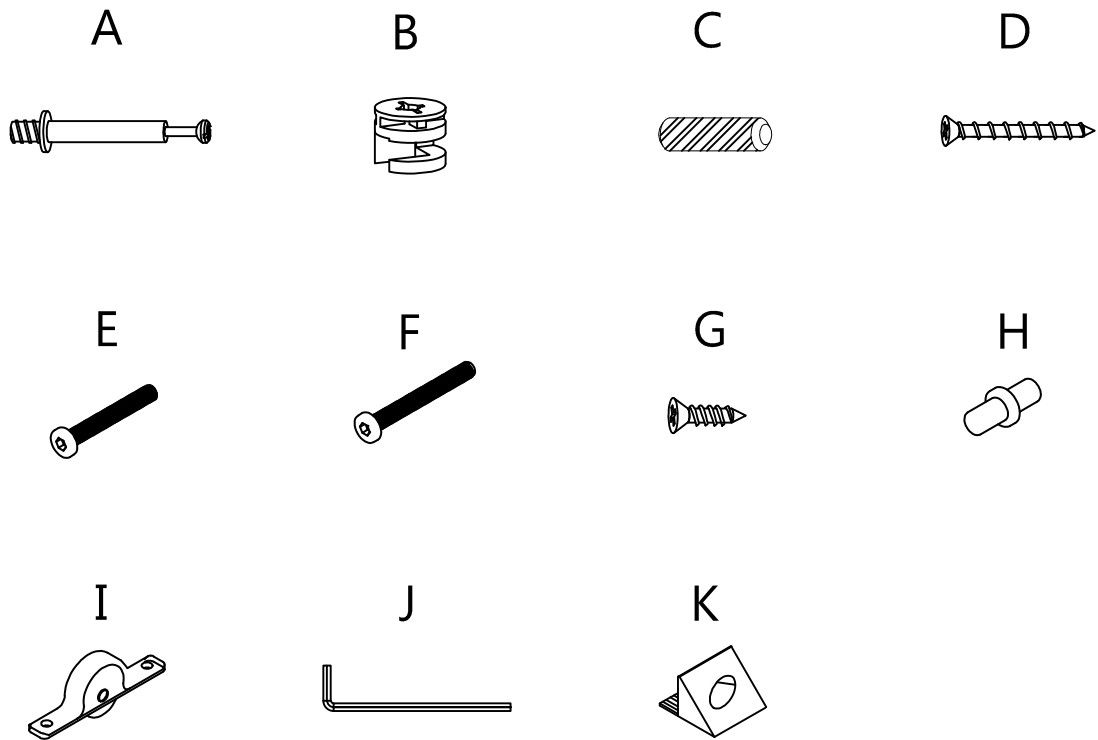

## IMPORTANT:

1. Do not tighten bolts / screws completely until all bolts / screws are lined up and inserted into holes.
2. Do not over tighten screws and bolts to avoid stripping
3. Please use hand tools to assemble this product. Do not use power tools.

# Included Accessories

---

Code	Description	Qty
1	Cabinet Top	1
2	Bottom Panel	1
3	Left Side Panel	1
4	Right Side Panel	1
5	Left neutral plate	1
6	Right neutral plate	1
7	Movable laminated plate	1
8	Back Panel	1
9	Wooden door	2
10	Left and right metal legs	2
11	Metal connecting rod	2
12	Vertical plate	2

# The Accessoriess

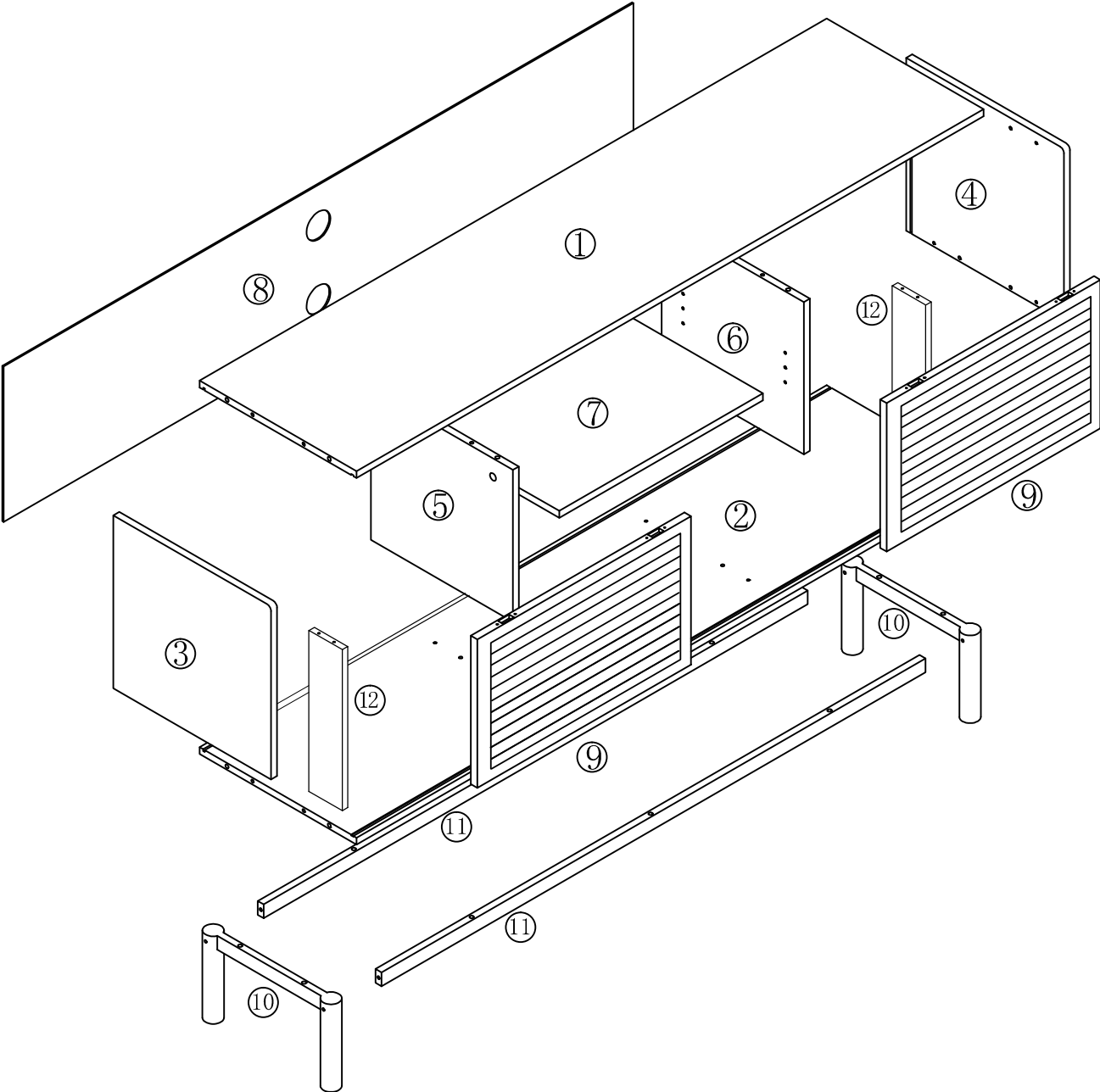

# Step 1

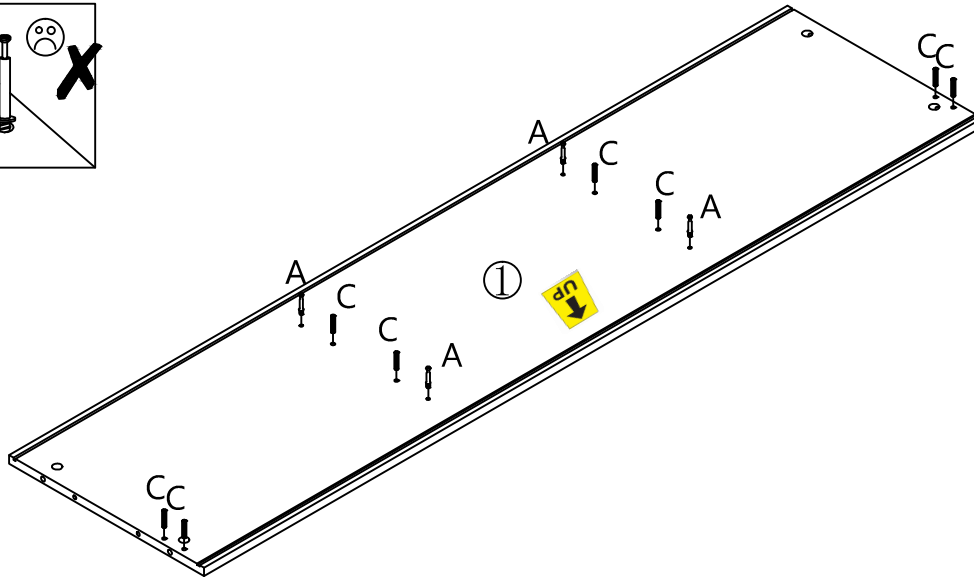
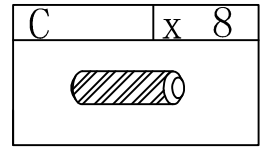
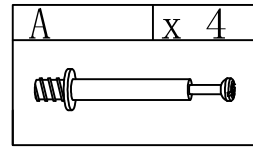
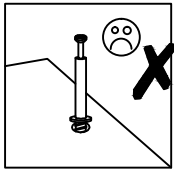
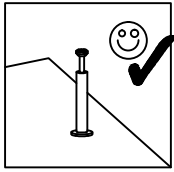

# Step 2

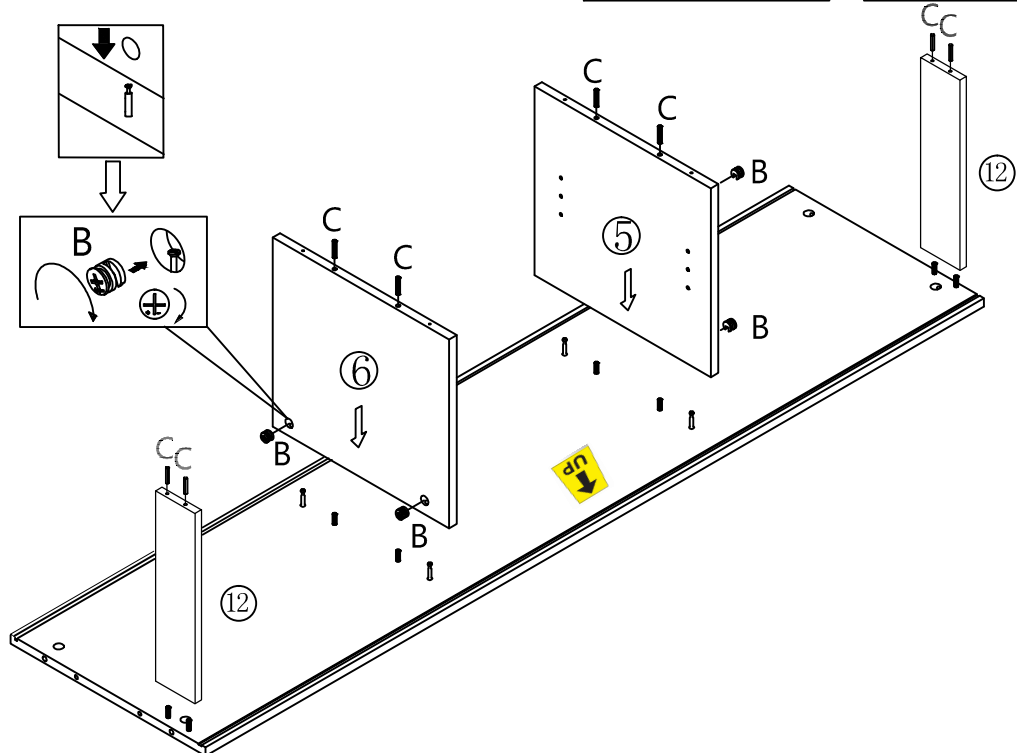
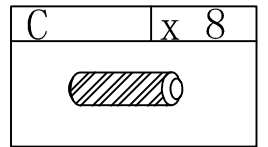
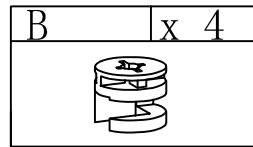
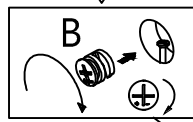
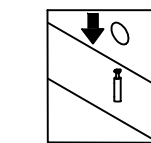

# Step 3

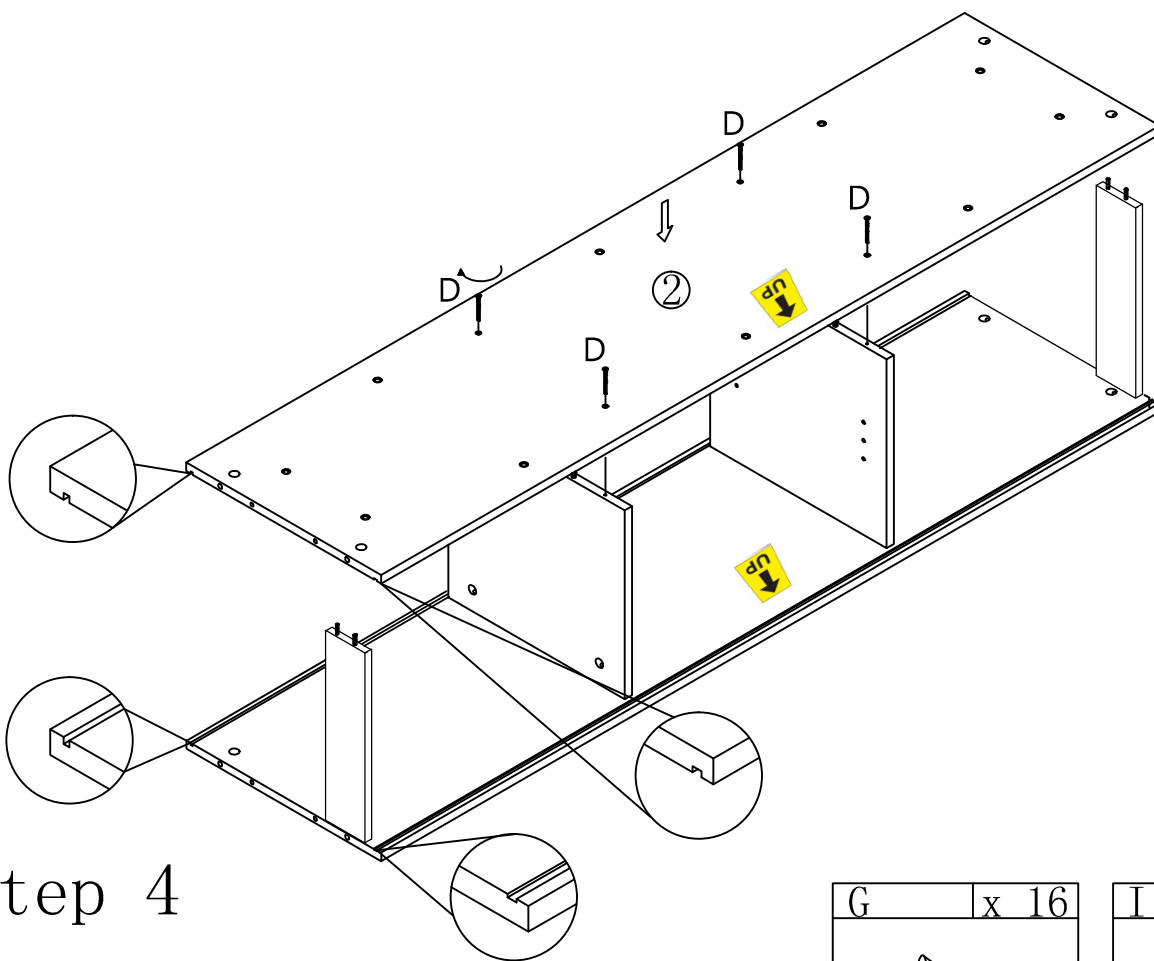
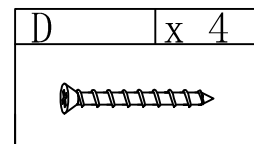

# Step 4

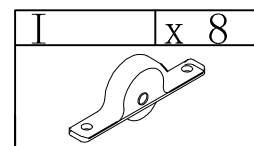
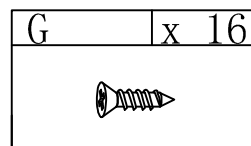

x2

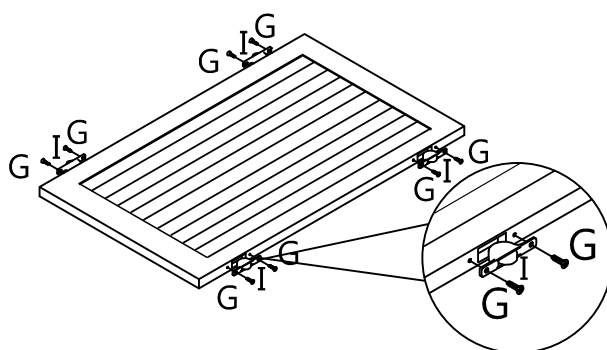

# Step 5

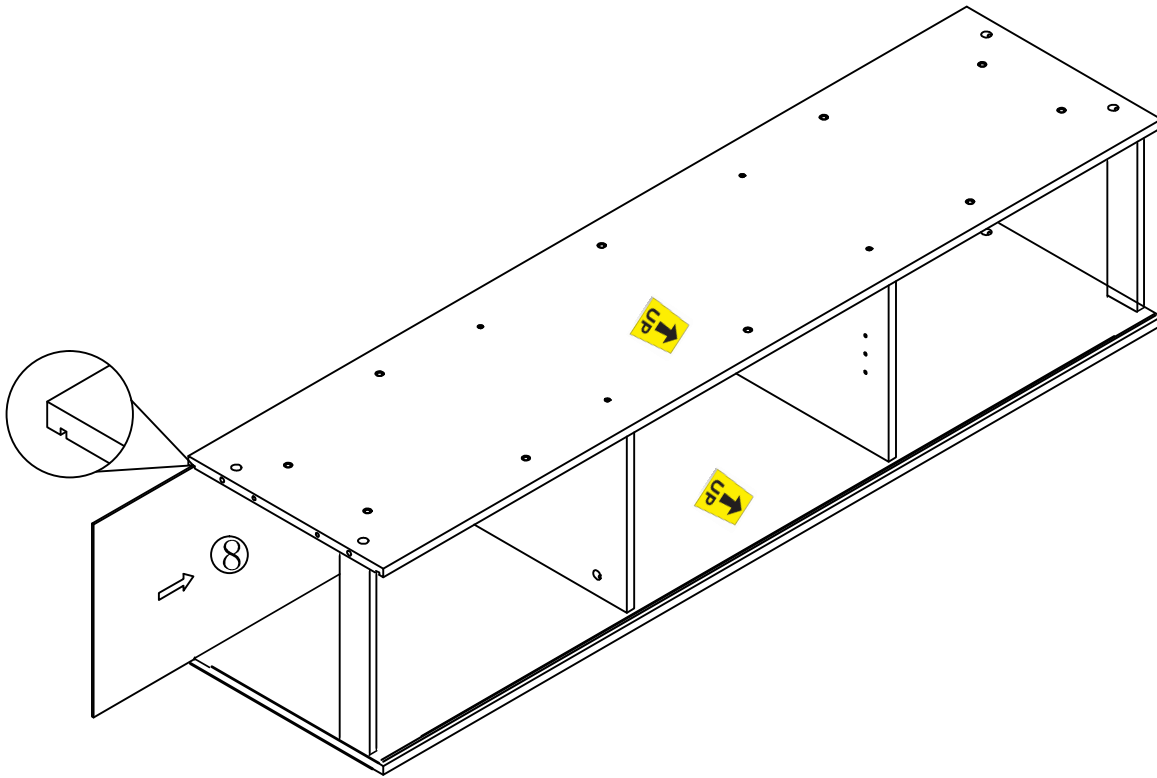

# Step 6

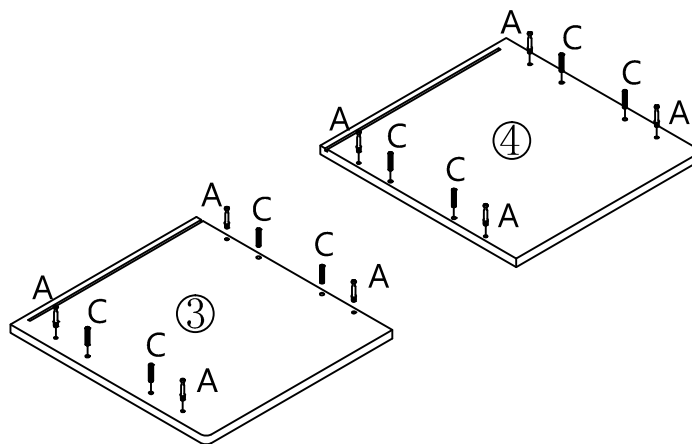
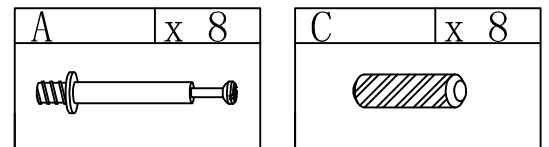

# Step 7

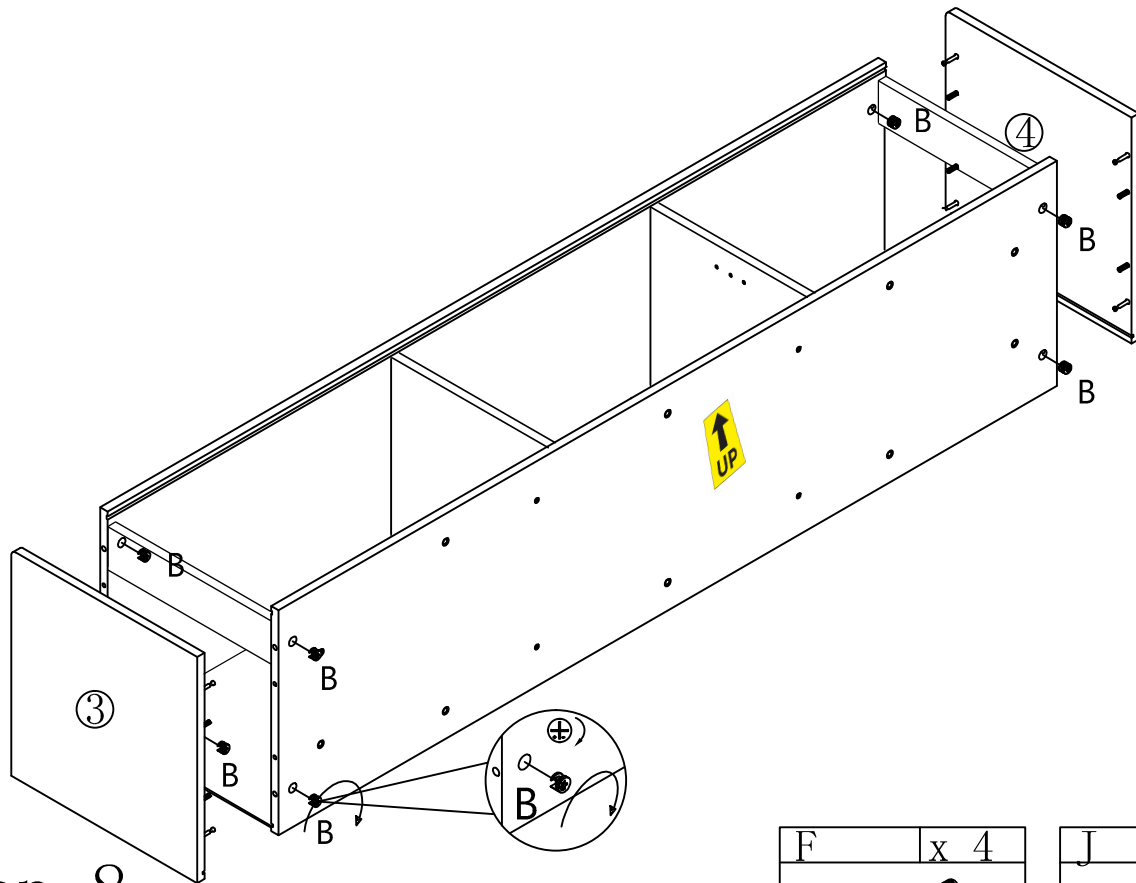
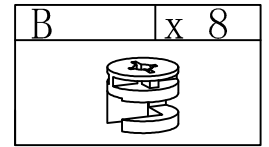

# Step 8

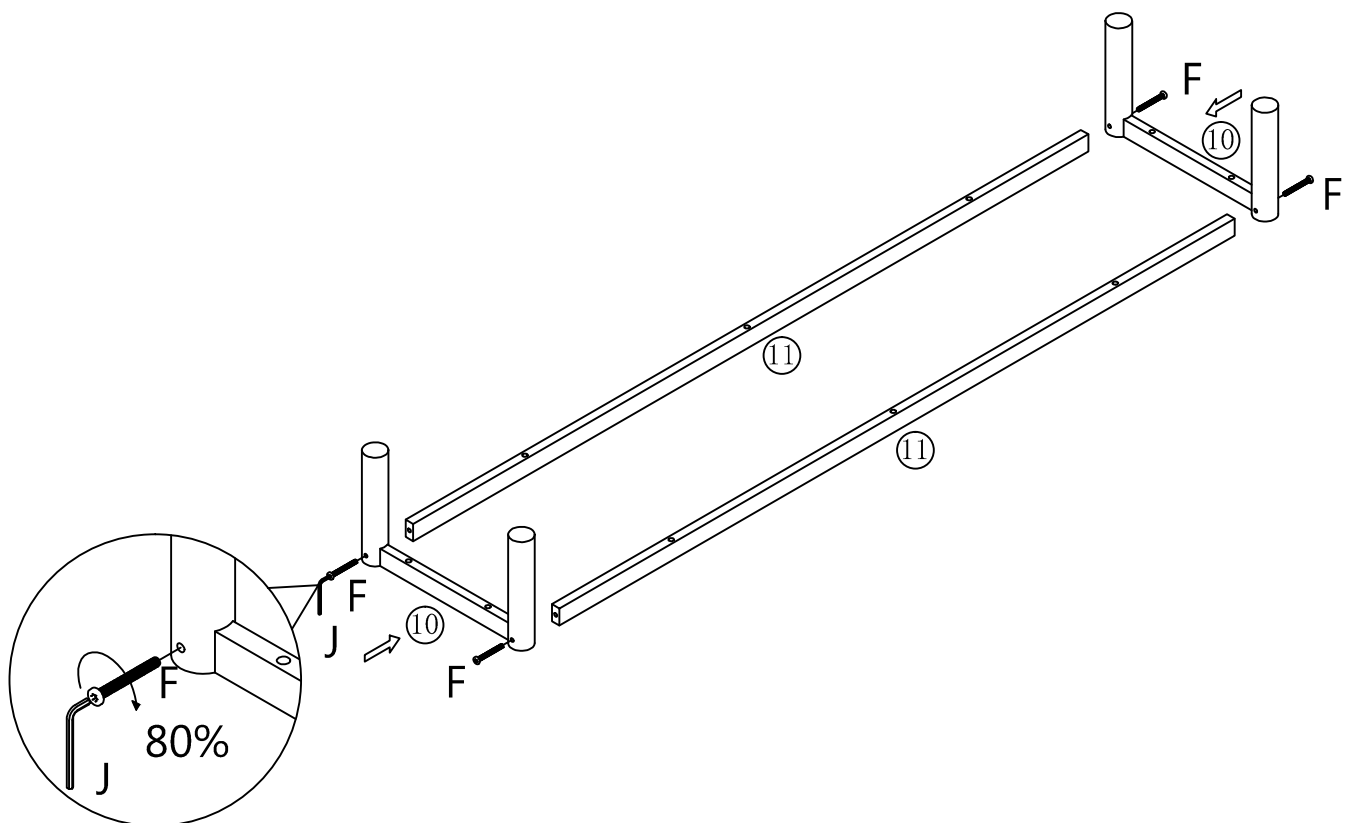
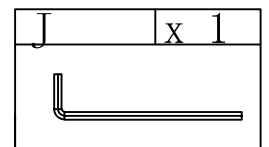
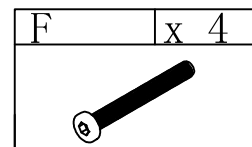

# Step 9

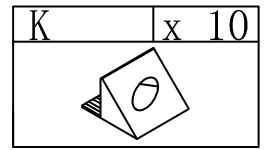
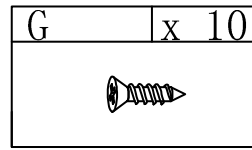
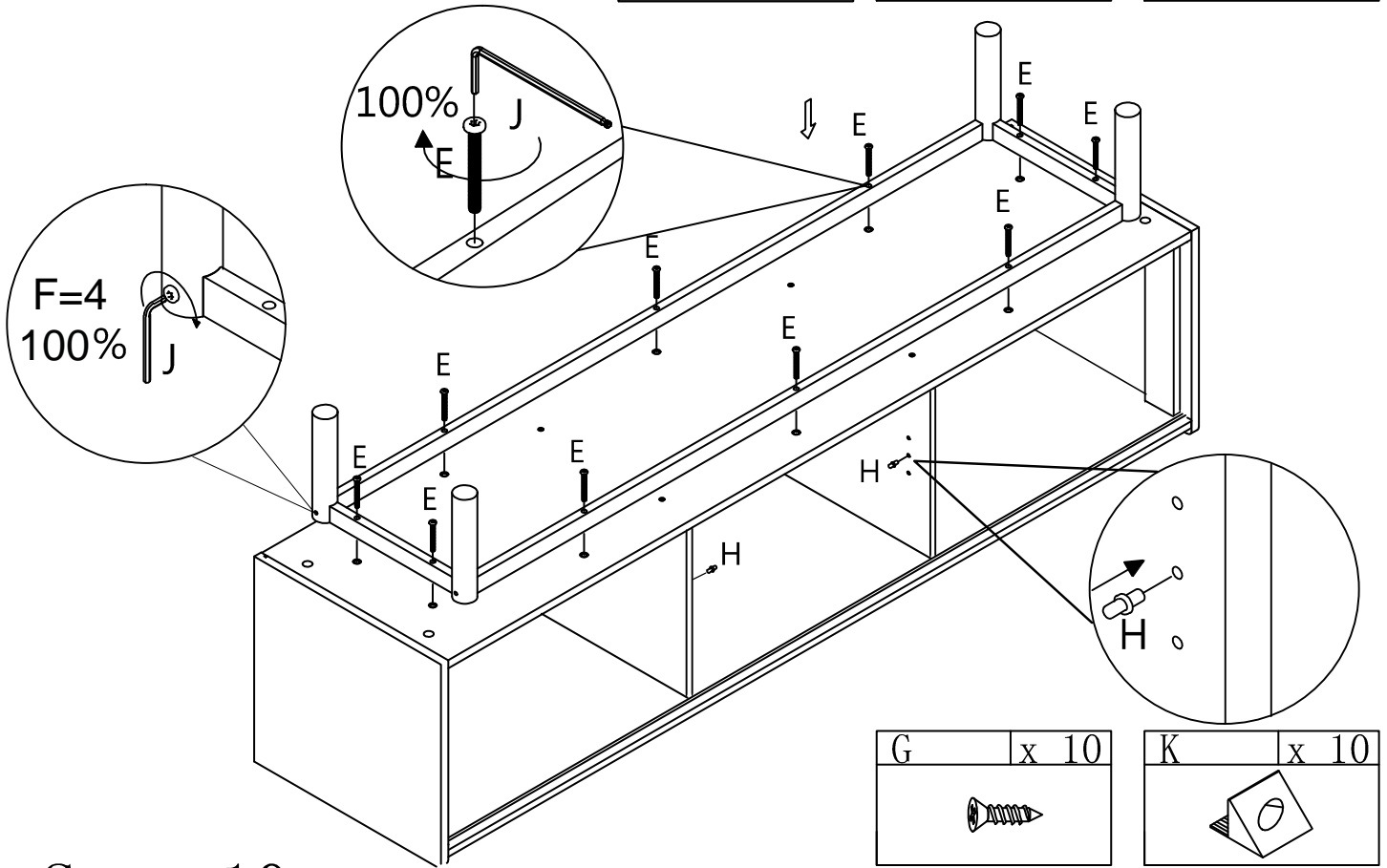
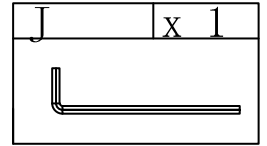
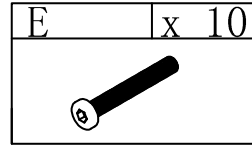
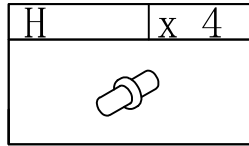

# Step 10

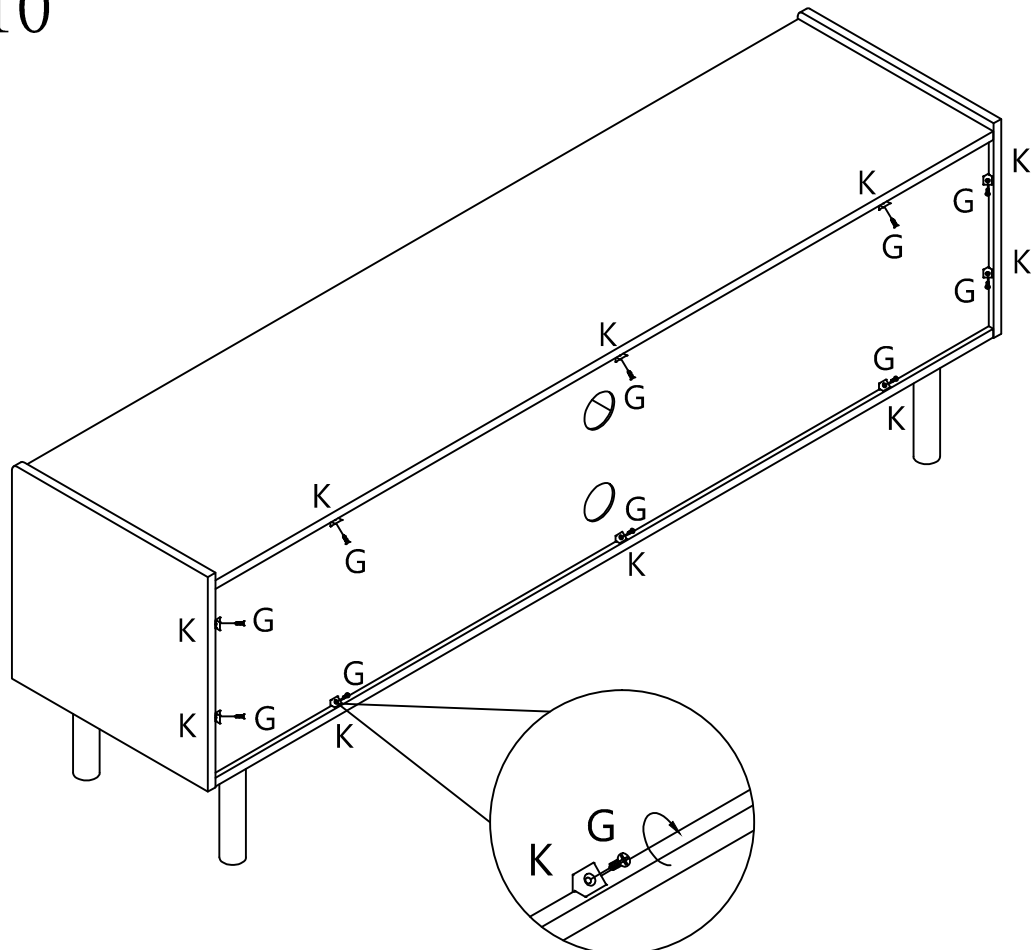

# Step 11

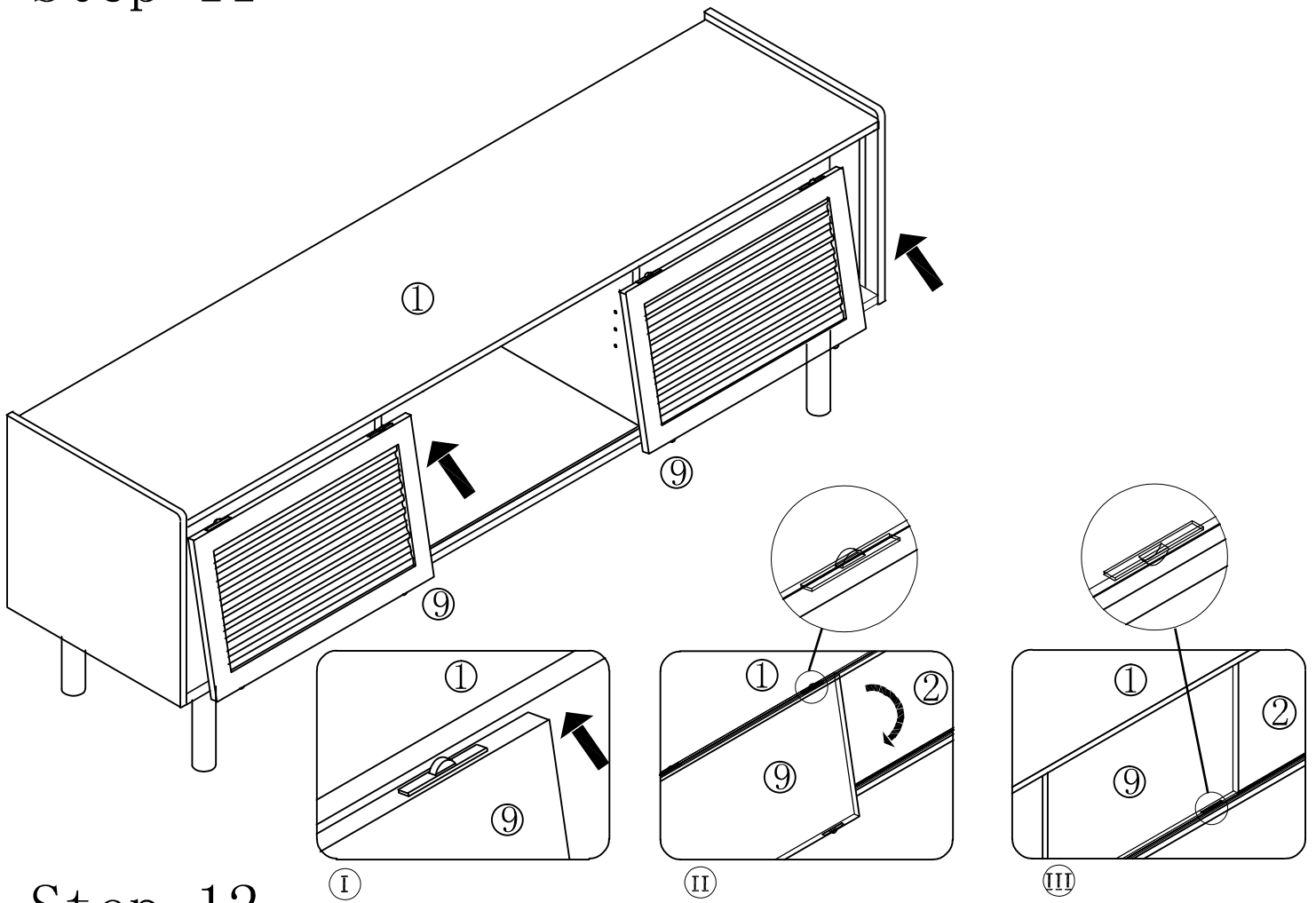

# Step 12

