

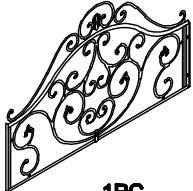









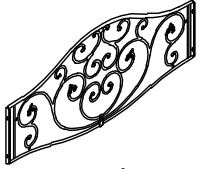

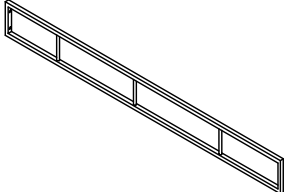
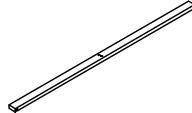

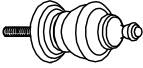
# ASSEMBLY INSTRUCTION

## METAL POSTER HB + FB

<b>A</b> Headboard Panel  1PC	<b>B</b> Headboard Post  2PCS	<b>C</b> Footboard Panel  1PC	<b>D</b> Footboard Post  2PCS	<b>E</b> Side Rail  2PCS
<b>F</b> Slat  3PCS	<b>G</b> Support Leg  3PCS	<b>H</b> Finial  4PCS	<b>I</b> Bolt $\text{Ø}5/16 \times 1-3/4$ "  8PCS	<b>J</b> Lock Washer $\text{Ø}5/16$ "  8PCS
<b>K</b> Flat Washer $\text{Ø}5/16 \times \text{Ø}3/4$ "  8PCS	<b>L</b> Plastic Washer $\text{Ø}5/16$ "  8PCS	<b>M</b> Sunk Bolt $\text{Ø}1/4 \times 3/4$ "  8PCS	<b>N</b> Sunk Bolt $\text{Ø}1/4 \times 1-1/2$ "  6PCS	<b>O</b> Allen Wrench 5mm  1PC
<b>P</b> Allen Wrench 4mm  1PC	<p>This page lists all the contents included in the box. Please take the time to identify the hardware as well as the individual components to this product. As you unpack and prepare for assembly, place the contents on a carpeted or padded area to protect them from damage.</p>			

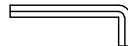
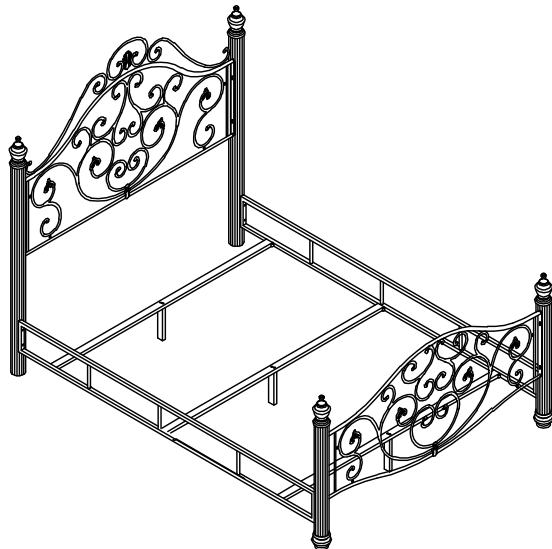

- 1** Use the Sunk Bolts(M) to tighten the Headboard Panels (A) with the Headboard Posts(B) by 4mm Allen Wrench(P). Directly screw the Finials(H) onto the Headboard Posts(B).

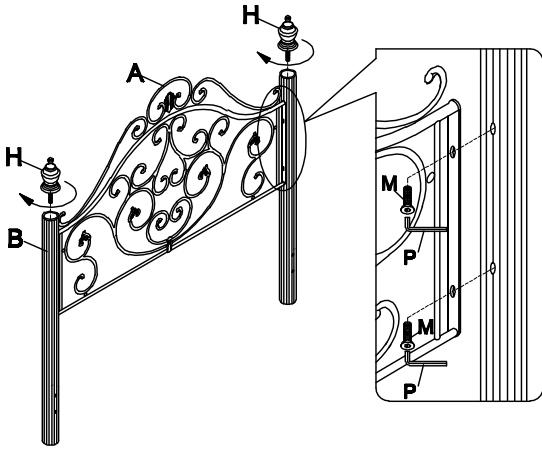

- 2** Use the Sunk Bolts(M) to tighten the Footboard Panels(C) with the Footboard Posts(D) by 4mm Allen Wrench(P). Directly screw the Finials onto the Footboard Posts(D).

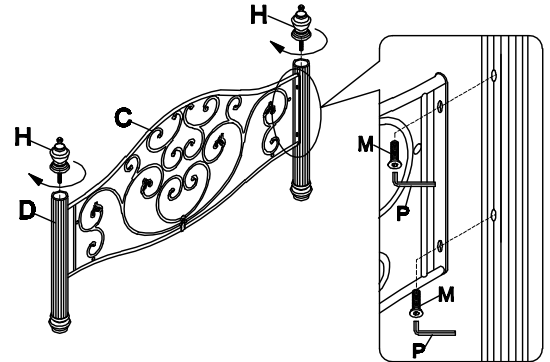

- 3** Use Bolt(I), with Lock Washer(J) and Plastic Washer(L) to connect Side Rails(E) onto Headboard and Footboard Panels, by 5mm Allen Wrench (O).

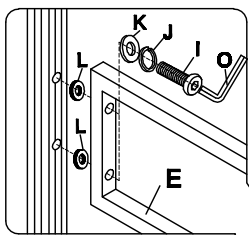

- 4** Use Sunk Bolt(N) to tighten the Support Legs(G) onto Slats(F), by 4mm Allen Wrench(P).

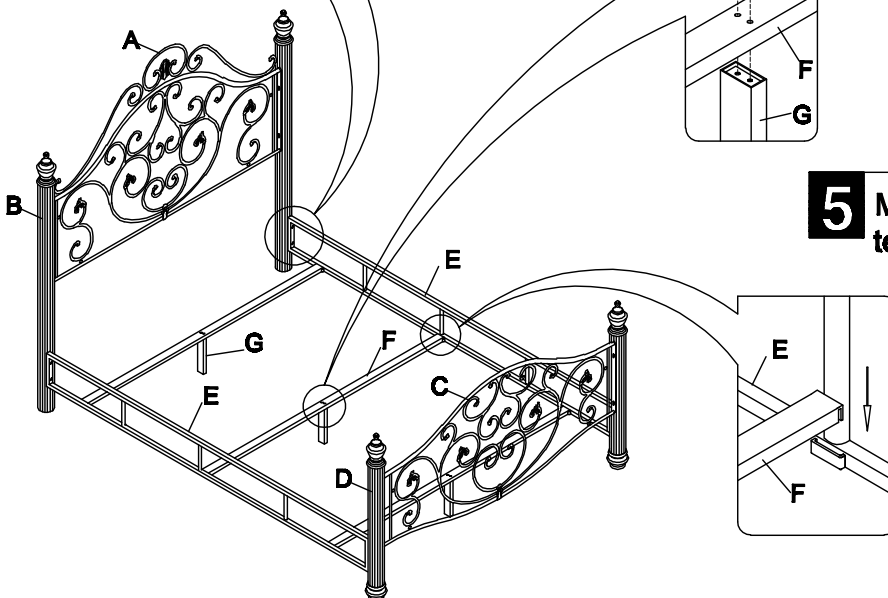
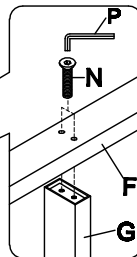

- 5** Make sure the Slats(F) are properly tenoned onto Side Rails (E).

### Cleaning & Care

Treat surface with care. Surface is resistant to scratches but is not scratch resistant. Clean surfaces with a dry or damp soft cloth. Do not use abrasive cleaners. Hardware may loosen over time. Periodically check that all connections are tight.