

LOUNG CHAIR

ASSEMBLY INSTRUCTION



Assembly Instruction

ASSEMBLY TIPS:

1. Remove hardware from box and sort by size.
2. Please check to see that all hardware and parts are present prior to start of assembly.
3. Please follow attached instructions in the same sequence as numbered to assure fast & easy assembly.







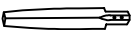

Warning !

1. Don't attempt to repair or modify parts that are broken or defective .Please contact the store immediately.
2. This product is for home use only and not intended for commercial establishment.

PARTS IDENTIFICATION

z HARDWARE IDENTIFICATION

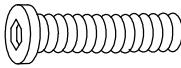
A	CUSHION		1PC
B	FRONT LEG		2PCS
C	BACK LEG		2PCS

NO	DESCRIPTION	FIGURE	Q'TY
1	Ø LOCK WASHER 5/16"		8PCS
2	Ø FLAT WASHER 5/16"		8PCS
3	Ø BOLT 5/16"X2"		8PCS
4	Ø ALLEN KEY 5/16"		1PC

STEP:1

Bolt front leg to seat box with cushion by using #4 allen key, #3 bolts, #1 lock washer, #2 flat washer and only hand tighten. Repeat for back leg.

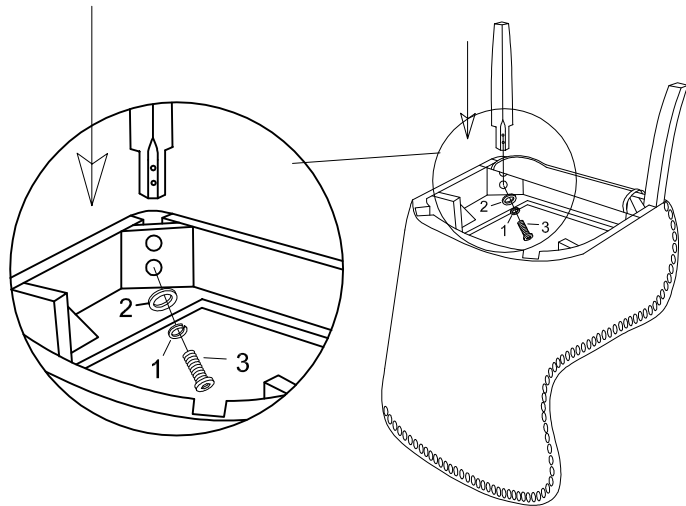

STEP:2

Assembly back leg to chair back by using #4 allen key, #3 bolts, #1 lock washer, #2 flat washer and only hand tighten. Repeat for front leg.

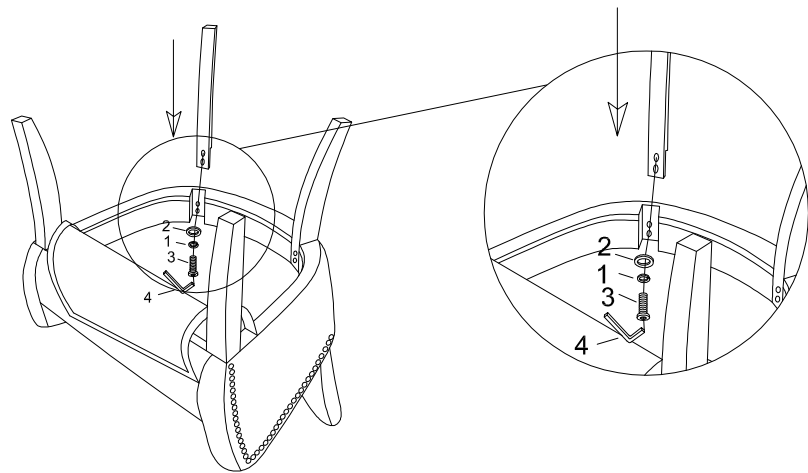

STEP:3

Place chair on the floor or flat surface and hold down with one hand while tightening all bolts with allen wrench.

