

ASSEMBLY INSTRUCTION

ITEM NO: D88033.D88034.D88035.D88036.D88037-O

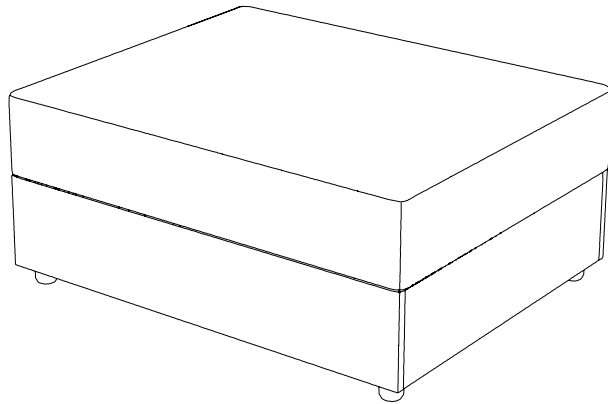

PARTS LIST

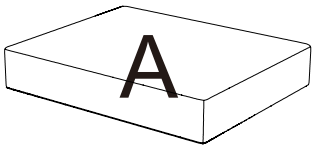

A

Seat cushion

x2

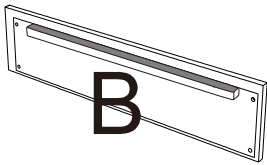

B

Base Frame Front Panel

x2

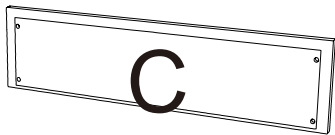

C

Base Frame Side Panel

x2

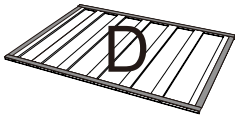

D

Slats

x1

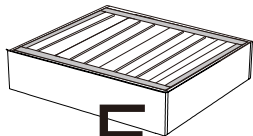



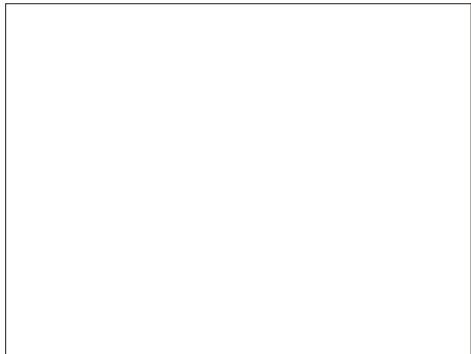

E

x1

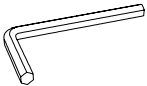
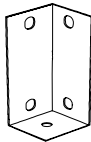
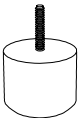

HARDWARE LIST

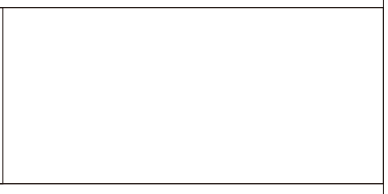
<p>1</p>  <p>1/4*1.8cm</p> <p>x16</p>	<p>5</p>  <p>30mm*100mm</p> <p>x1</p>	<p>7</p>  <p>x4</p>	<p>8</p>  <p>x4</p>
			

BEFORE ASSEMBLY

Open up Velcro of Non-Woven Fabric cover on the bottom to remove hardware, legs and parts.

1. Please open the black woven fabric with Velcro closure on the bottom of the frame then cut off the black straps before removing the parts for assembly.
2. After removing the cushion from the compress bag, please allow air to flow through the cushion for few days. You can try to fluff cushion by push in and push out on all four sides of the cushion. Hitting the top/front of the cushion with your hand to fluff them after installation.
3. Please allow at least 24 hours for the cushions to recover to its natural state after removing from the package.

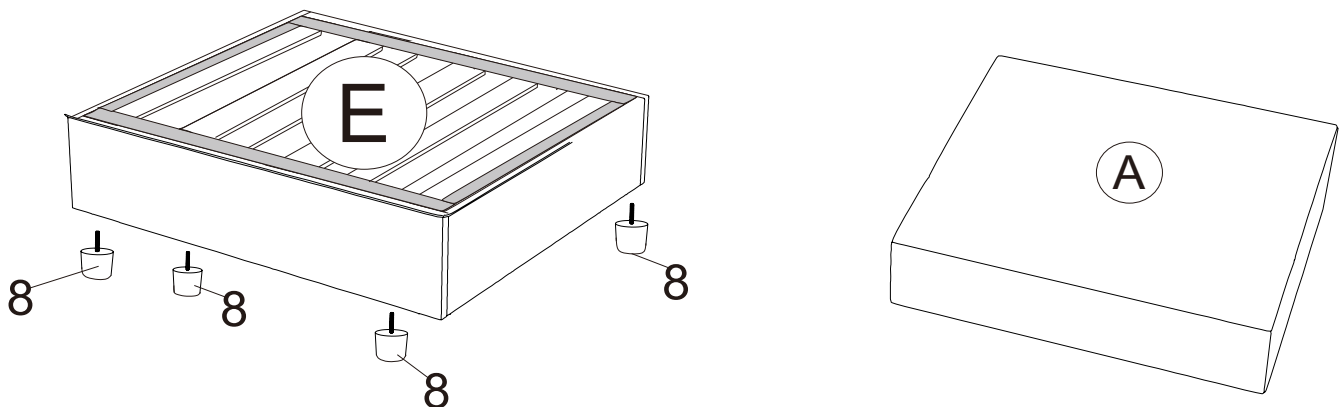
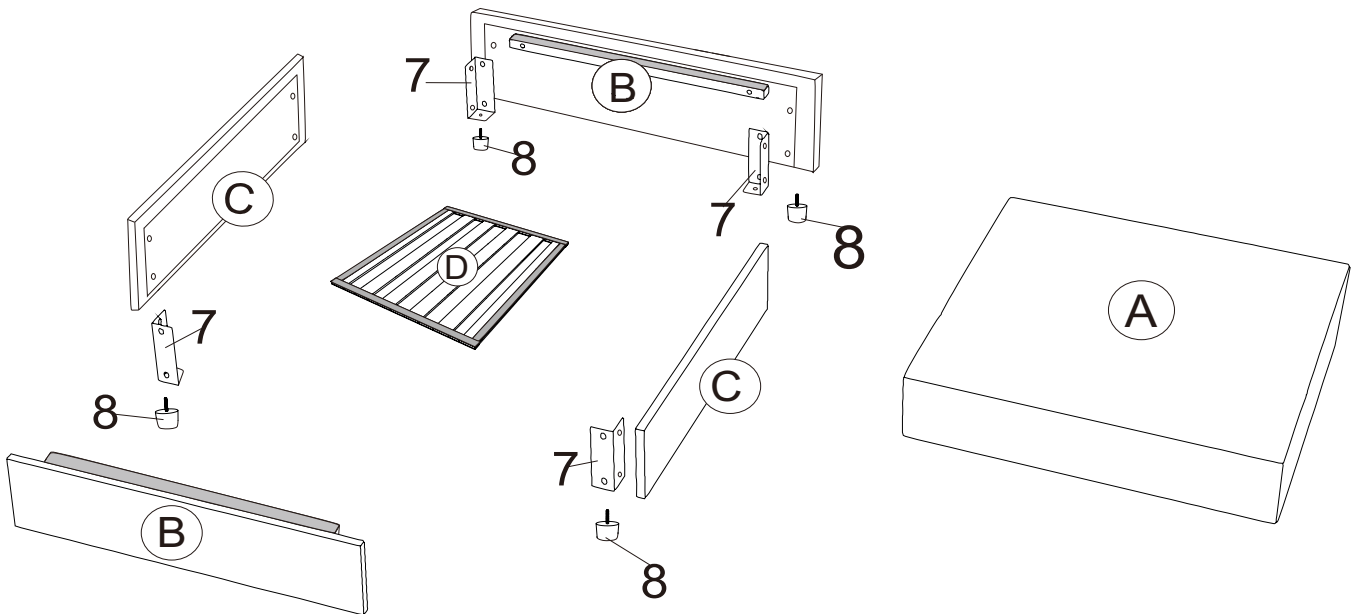
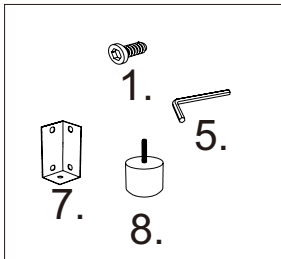
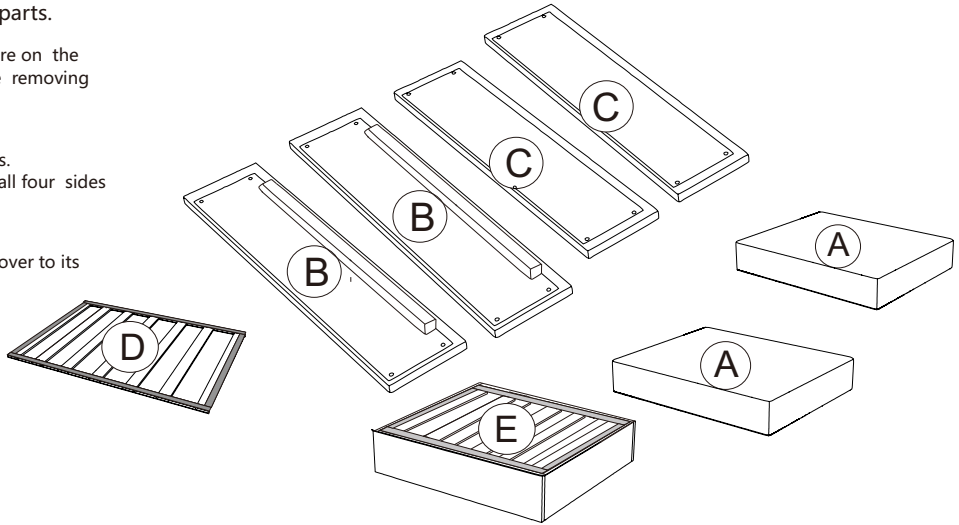

Step1

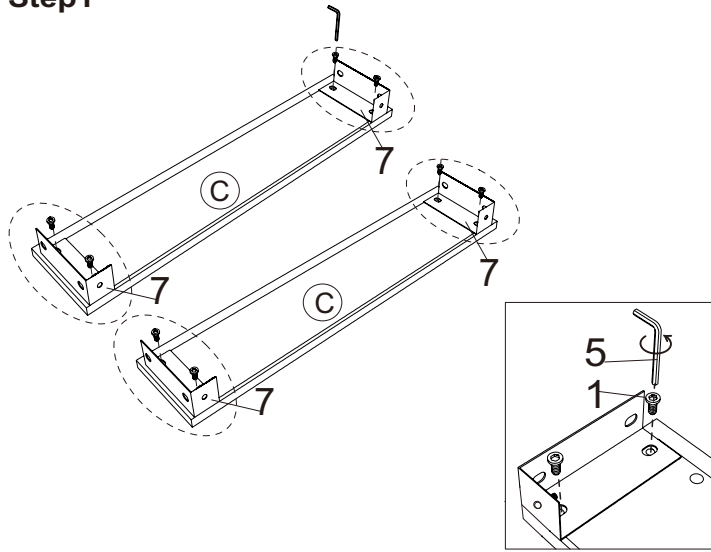

Step2

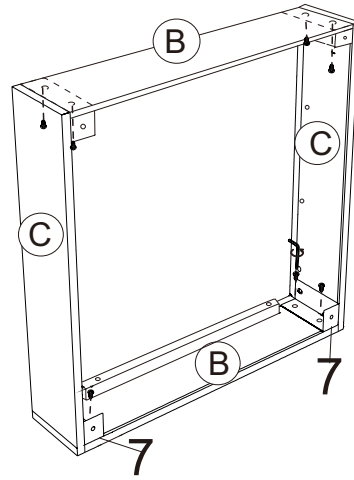

Make sure to align Part#B,C And7 at the same level. If there is any issue, use the oval screw holes to adjust.

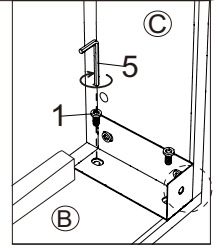

Step3

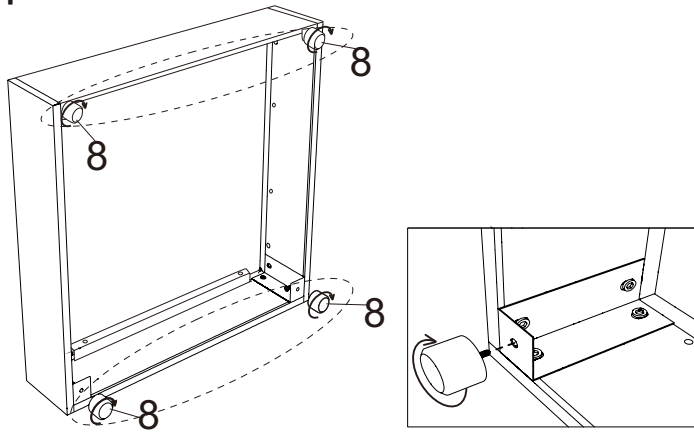

Step4

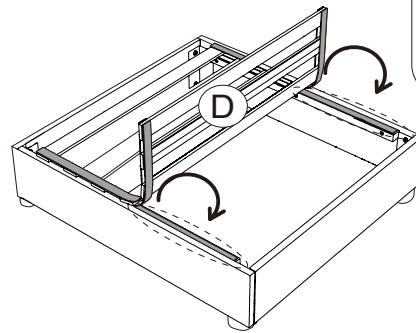

Face the Velcro upward.

Step5

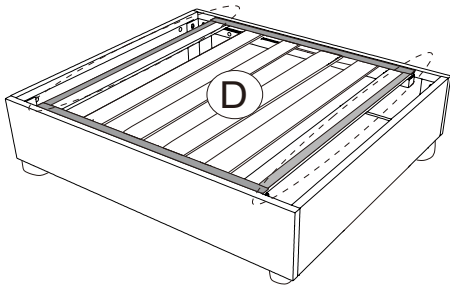

Face the Velcro upward.

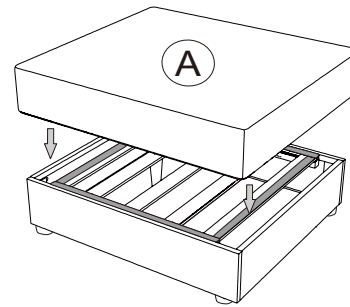

Step6

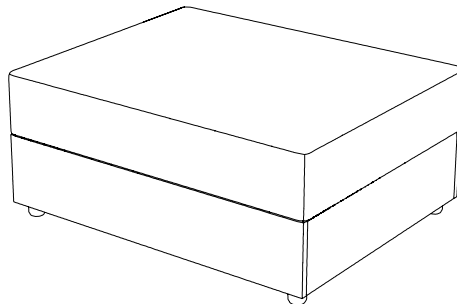

Step1

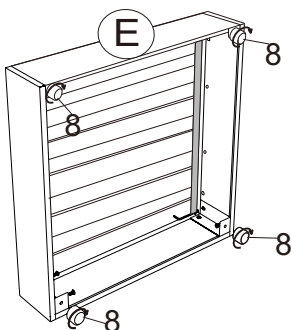

Face the Velcro upward.

