

WF315229
WF315230

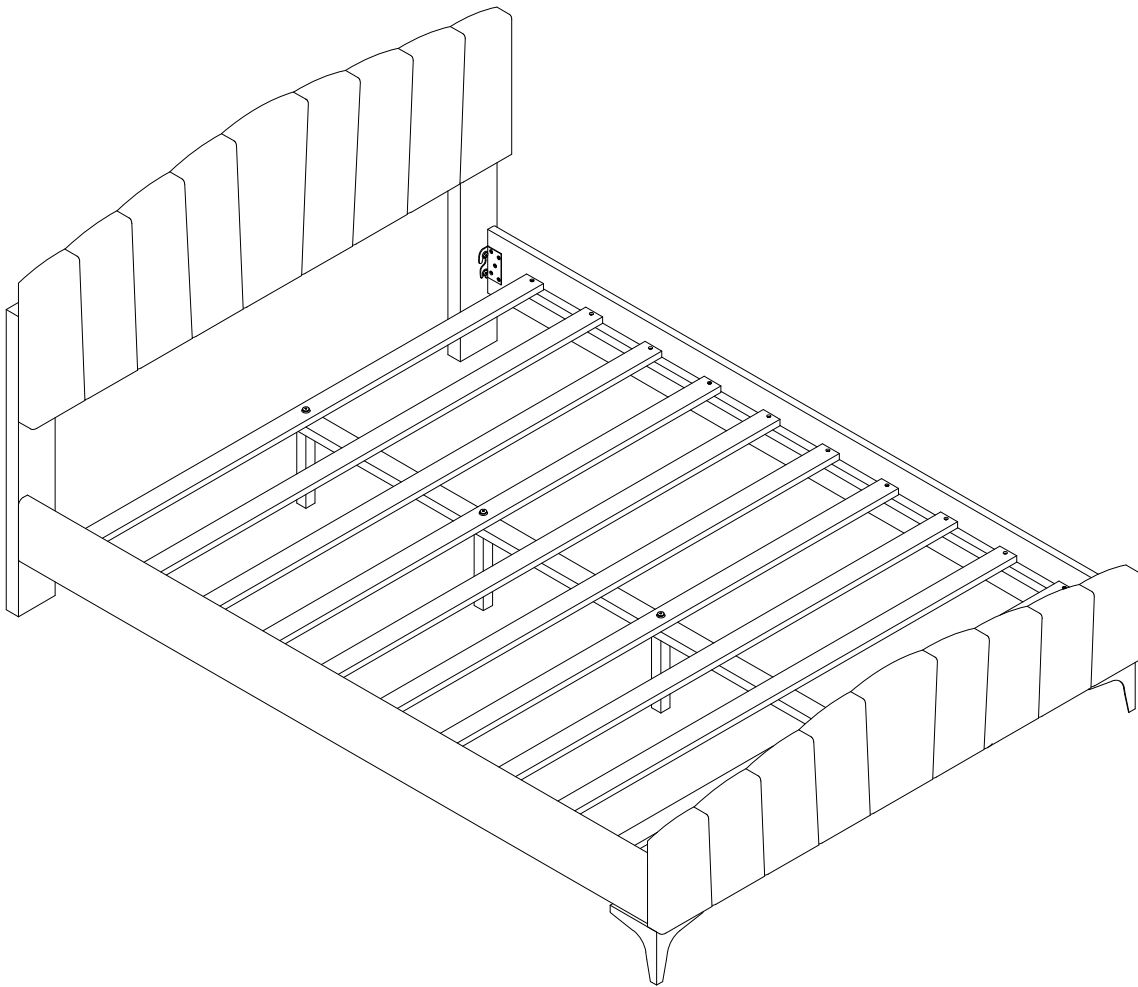

ASSEMBLY INSTRUCTIONS

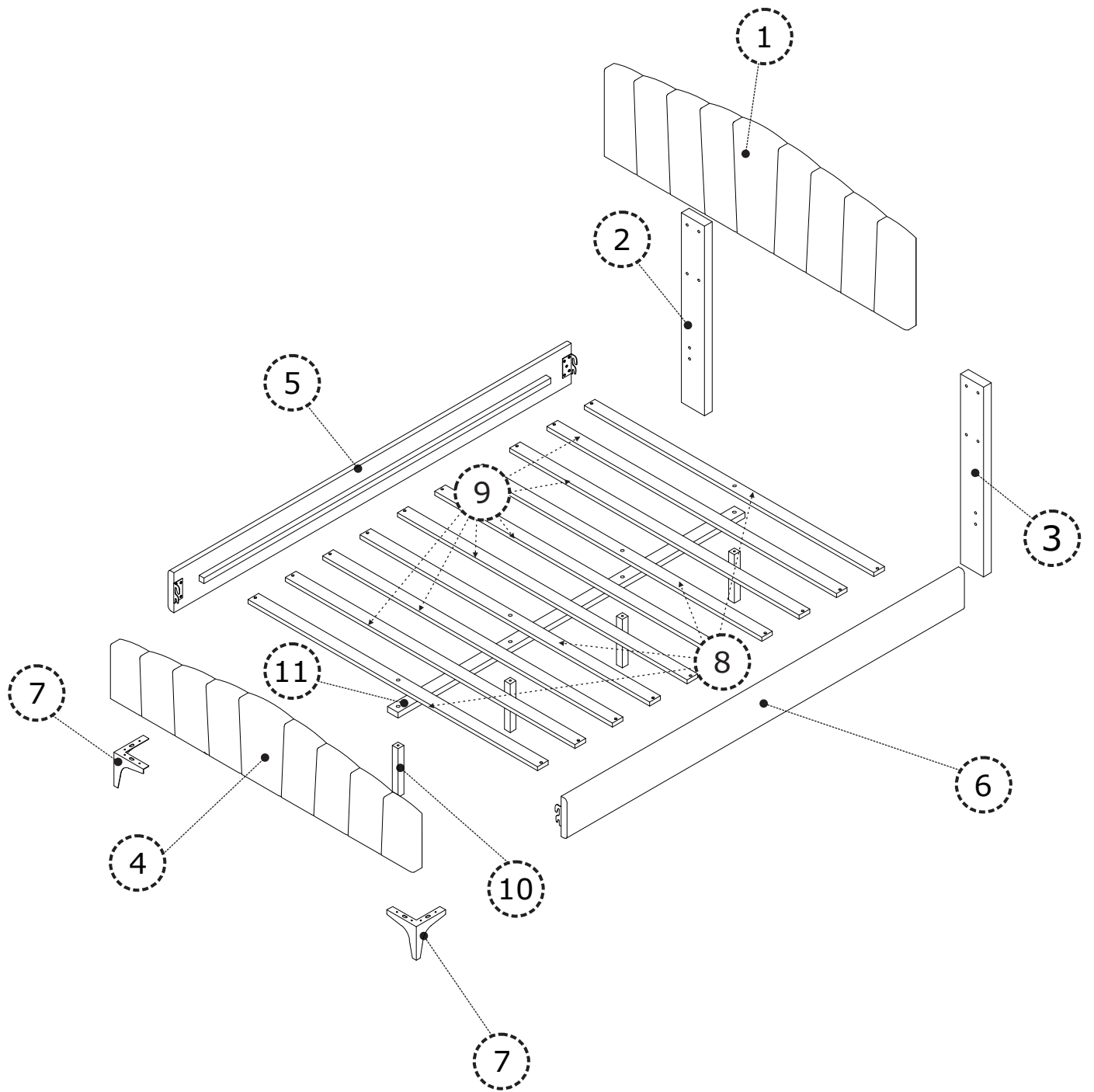

PARTS

Check that you've received
all parts listed below.

BOX: 1/2
WF315229

1 x 1

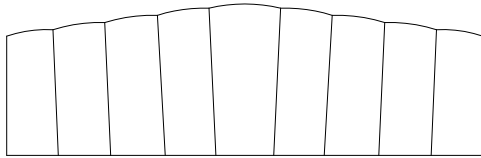

Head Board

4 x 1

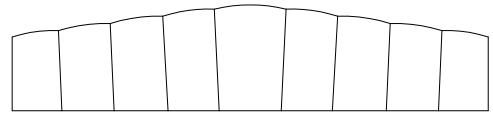

Foot Board

8 x 4

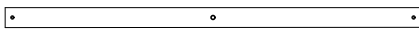

Slats

9 x 6

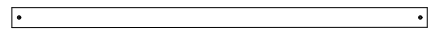

Slats

10 x 4



Support Legs

PARTS

Check that you've received
all parts listed below.

BOX: 2/2
WF315230

2 x 1



Head Leg left

3 x 1

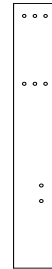

Head Leg Right

5 x 1



Side Board Left

6 x 1



Side Board Right

7 x 2

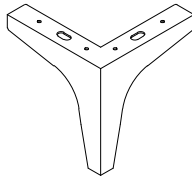

Legs

11 x 1

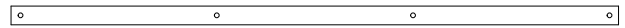

Support Slat



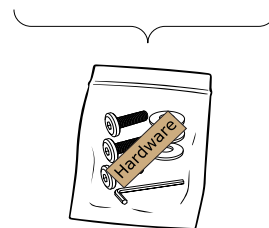





Hardware



HARDWARE

Check that you've received all hardware listed below.

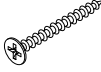
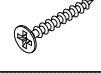
Hardware List

| No. | OUTLOOK | DESC | QTY |
|-----|---|--------------------------------|-----|
| (A) |  | Bolts 5/16"x20 mm | 2 |
| (B) |  | Bolts 5/16"x30 mm | 8 |
| (C) |  | Bolts 5/16"x60 mm | 4 |
| (D) |  | Bolts 5/16"x70 mm | 8 |
| (E) |  | Plain washer Ø19x1.5 mm | 22 |
| (F) |  | Spring washer Ø13x1 mm | 22 |
| (G) |  | Allen key 80x30x4 mm | 1 |
| (H) |  | Screws Ø4x30 mm | 20 |
| (I) |  | Screws Ø4x15 mm | 8 |
| (K) |  | Dowel Ø10 x 30 mm | 4 |
| | | | |
| | | | |
| | | | |
| | | | |
| | | | |
| | | | |
| | | | |
| | | | |
| | | | |

STEP 1

| | | | | |
|--|--|--|--|--|
| K x 4  | | | | |
|--|--|--|--|--|

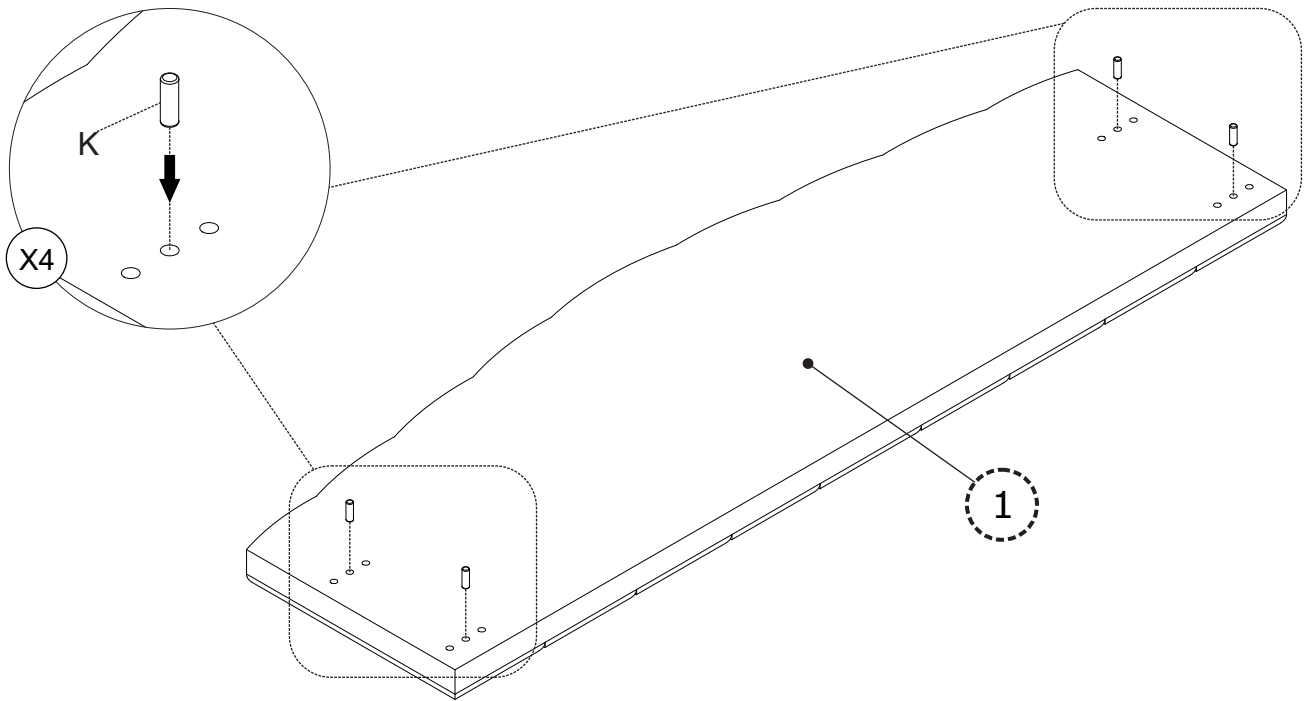

STEP 2

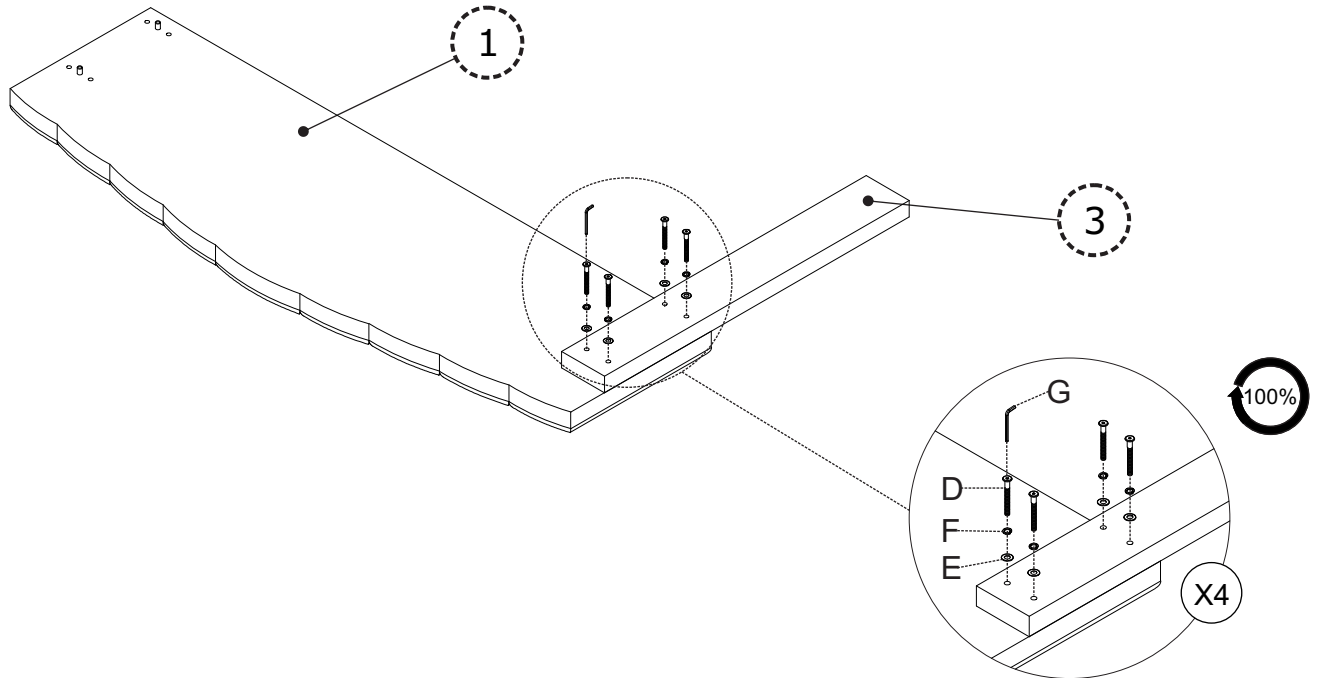
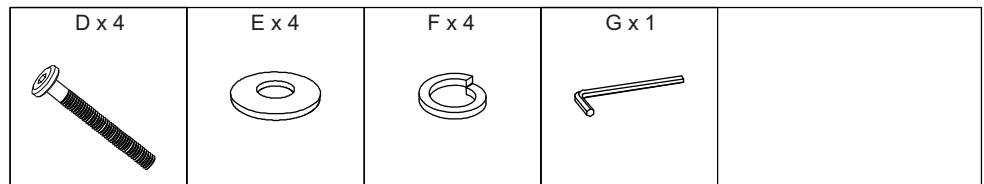

STEP 3

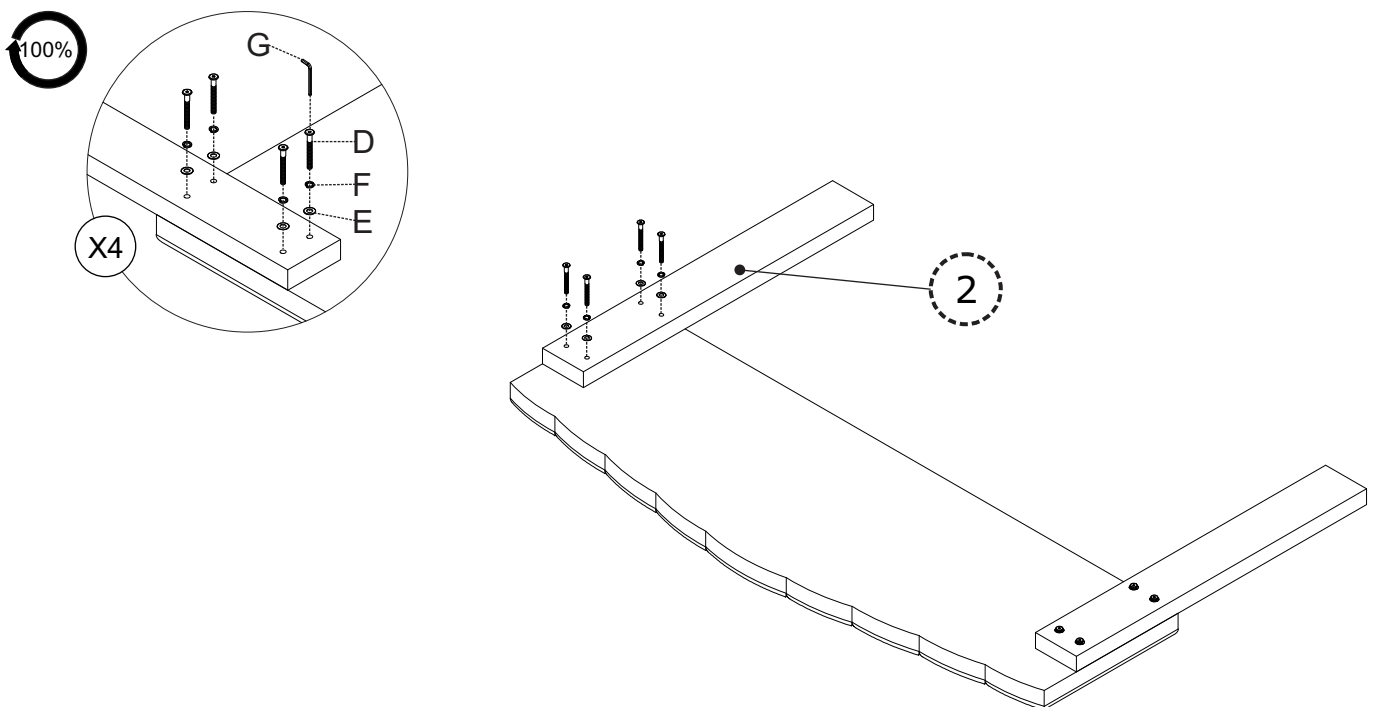
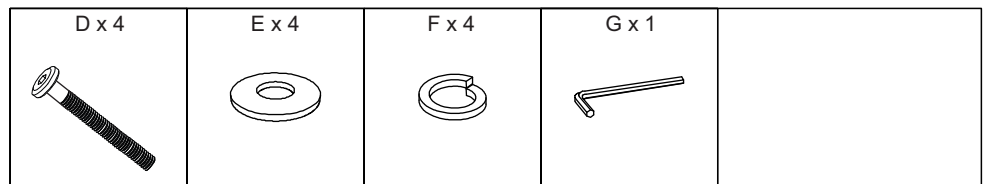

STEP 4

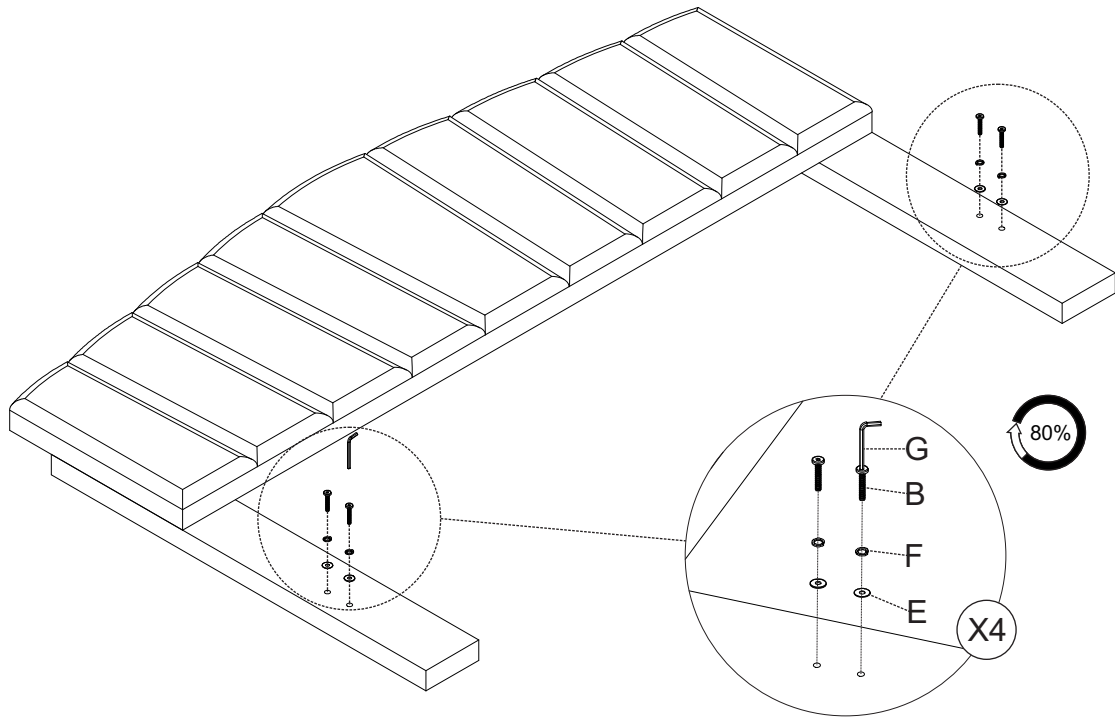
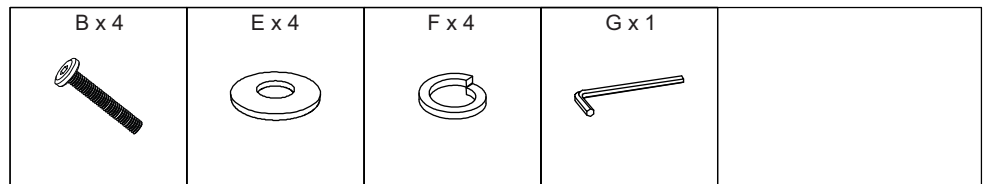

STEP 5

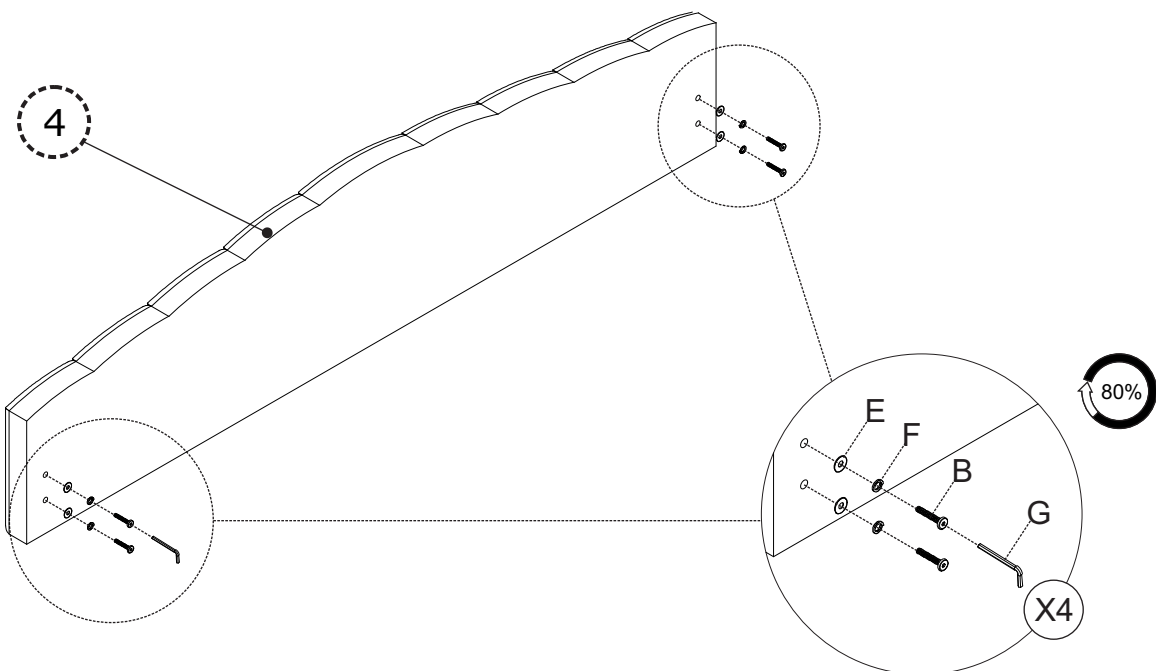
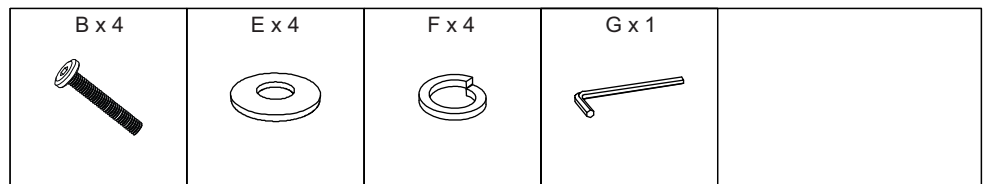

STEP 6

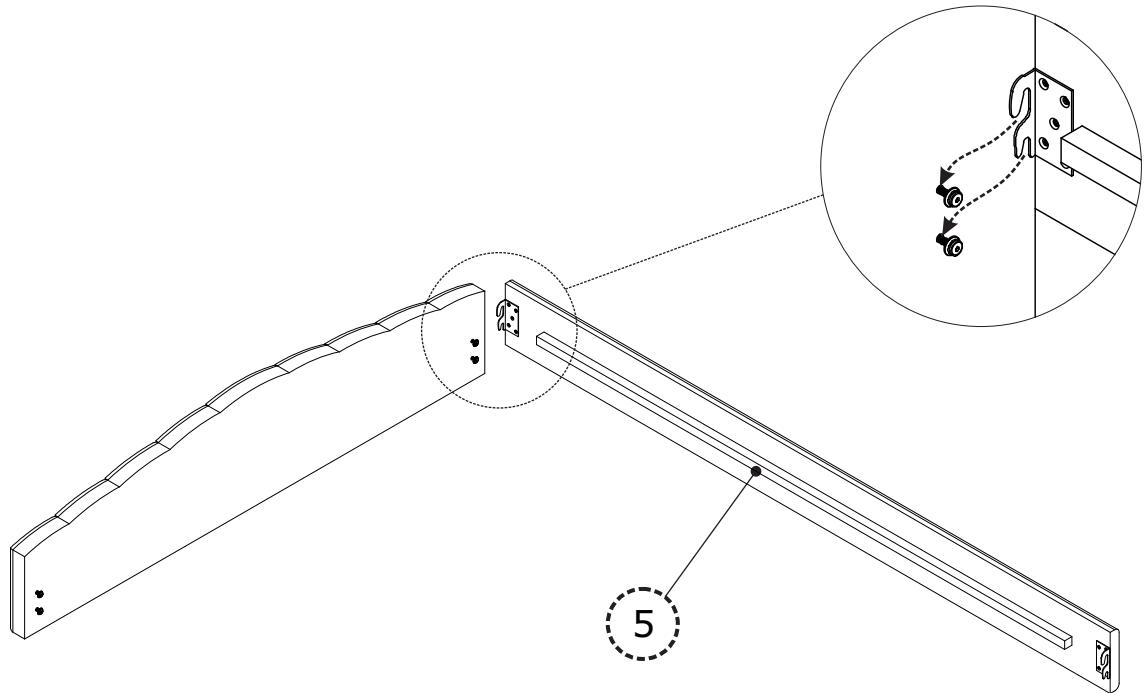
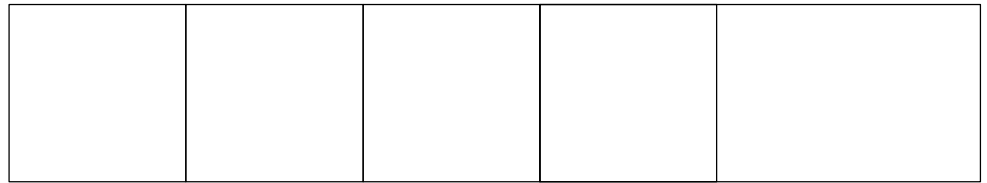

STEP 7

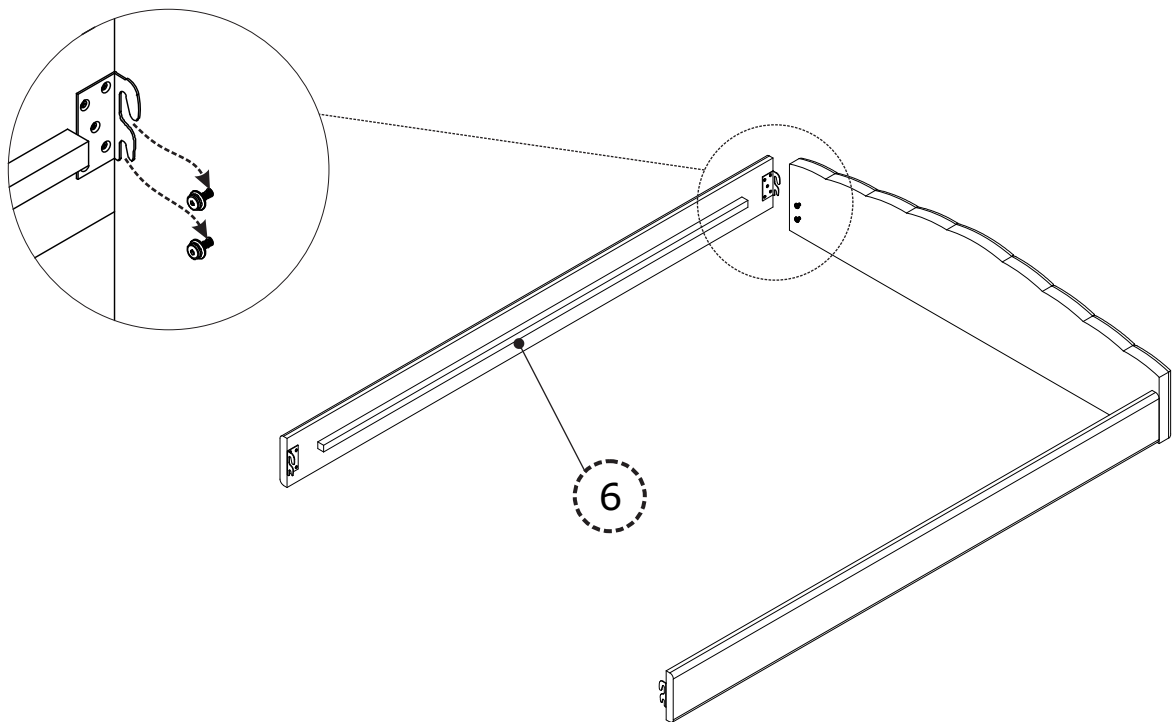
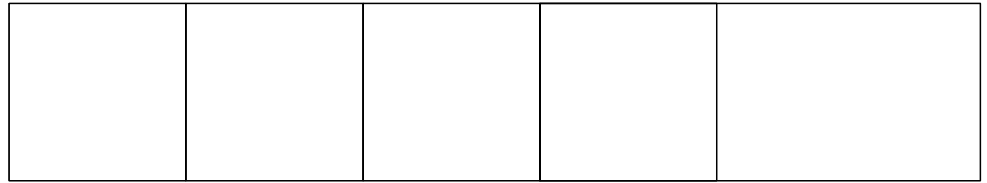

STEP 8

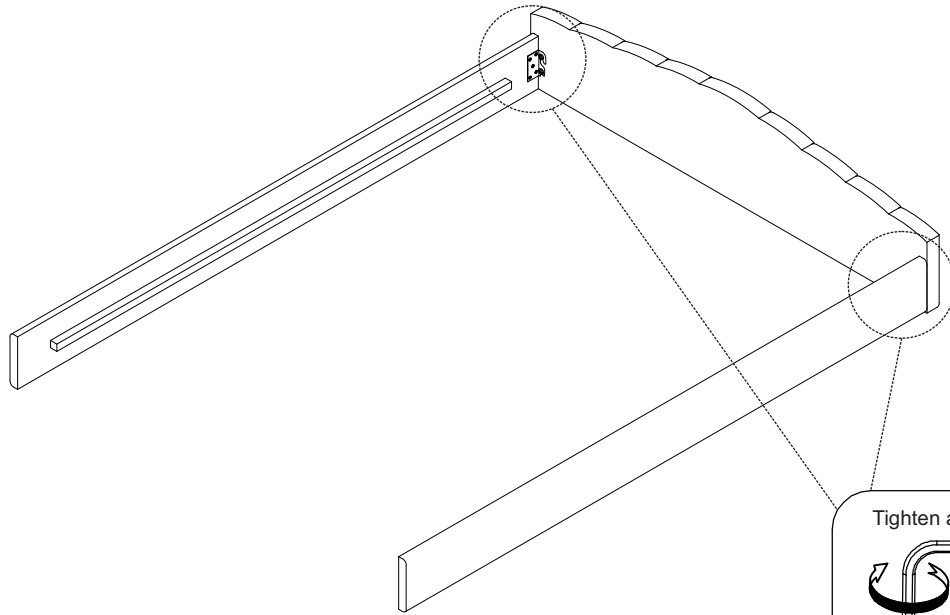
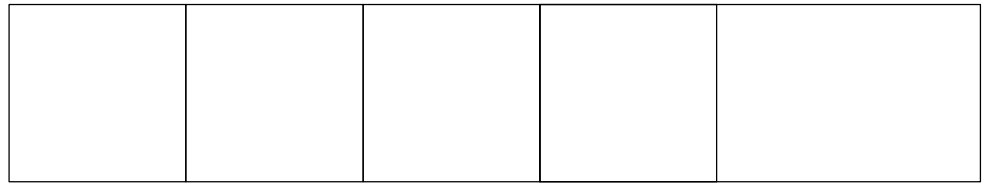

Tighten all screw bolts 100%

100%

STEP 9

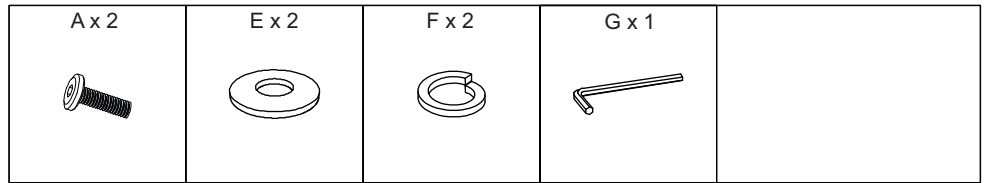

100%

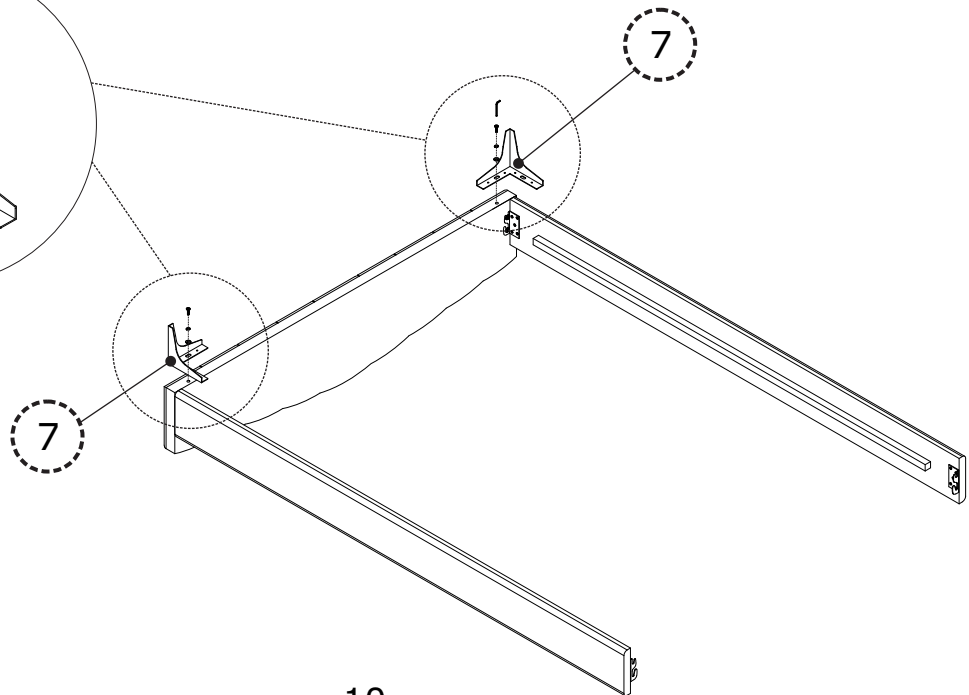
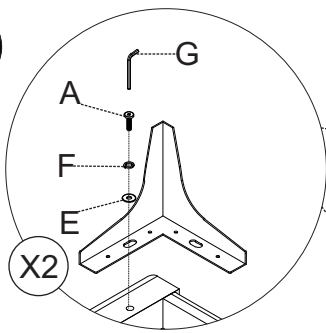

STEP 10

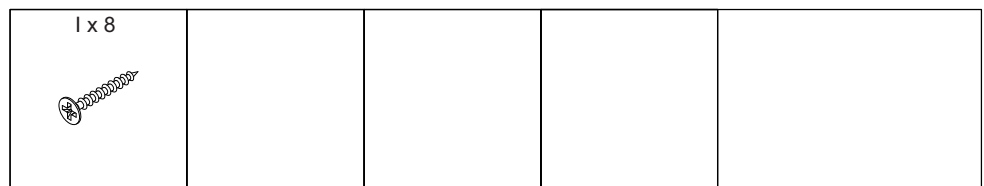

100%

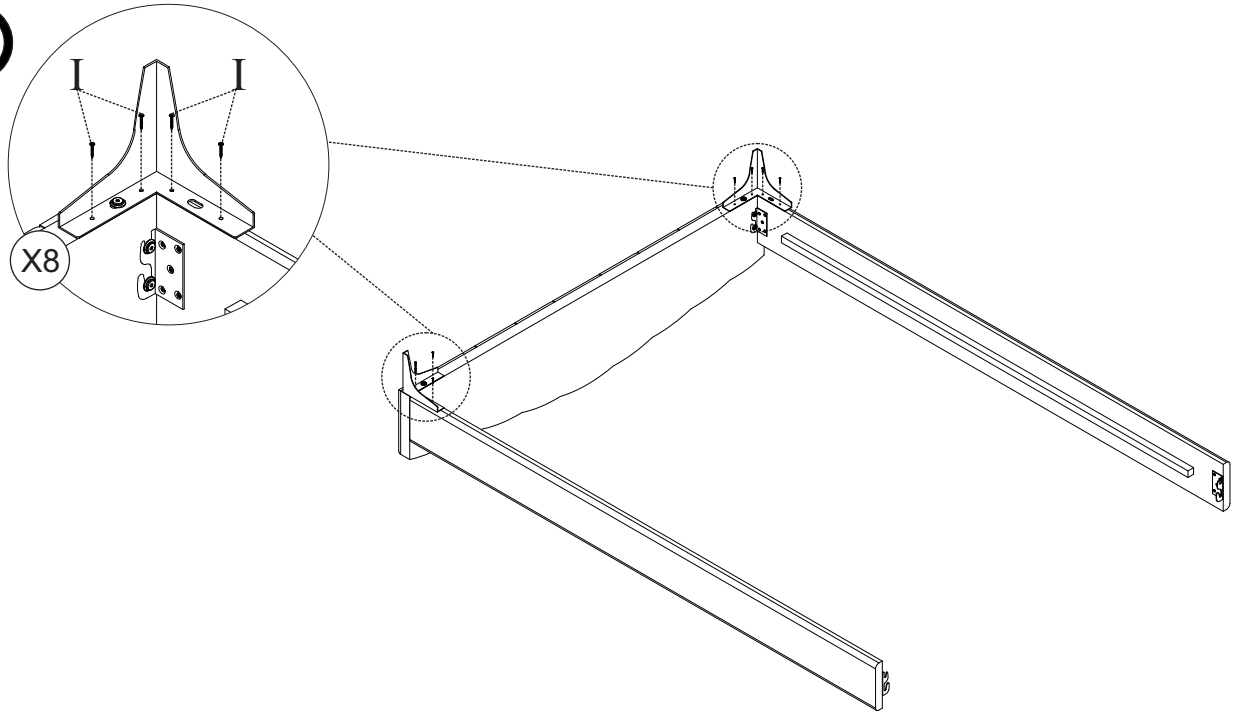

STEP 11

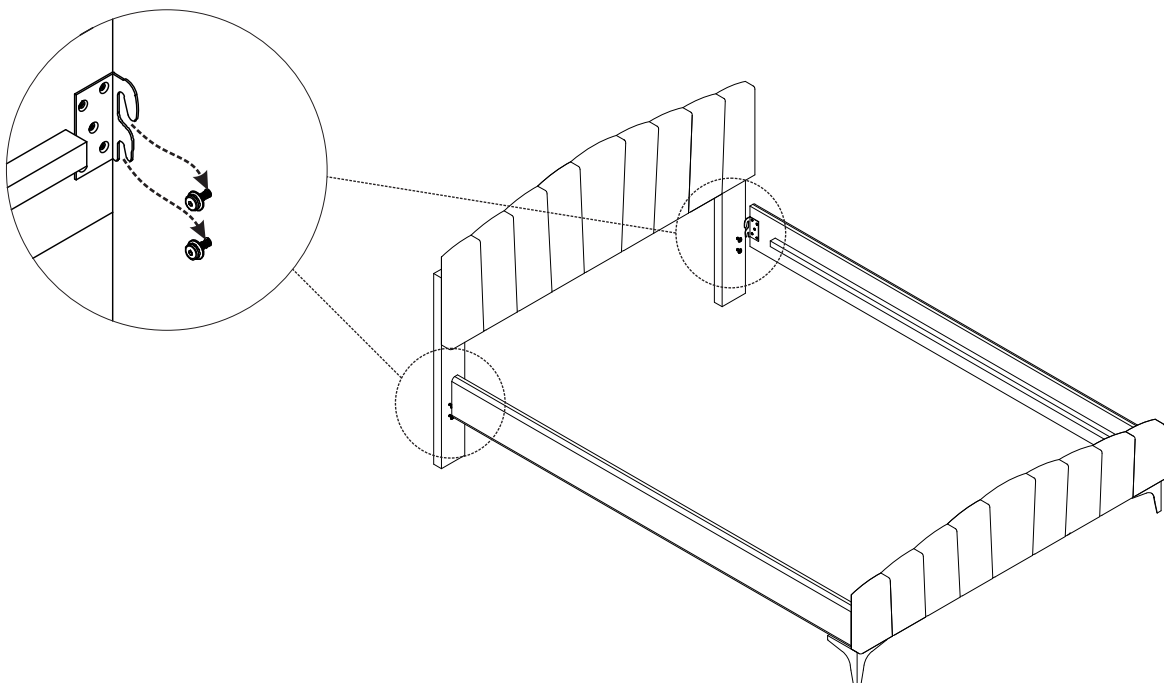
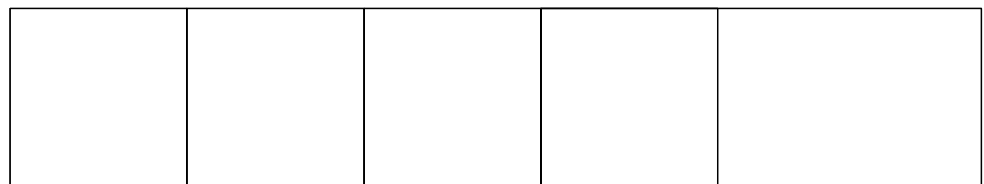

STEP 12

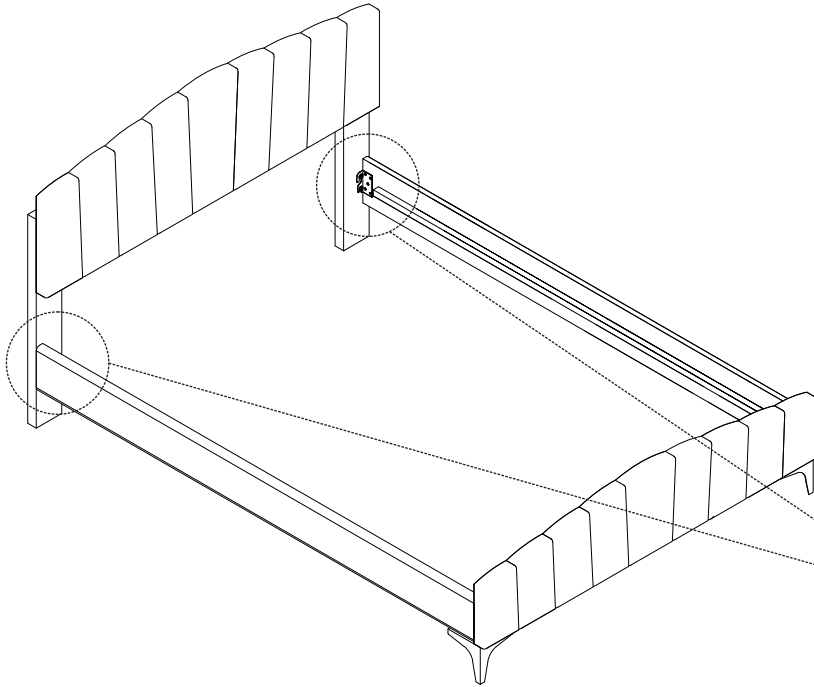
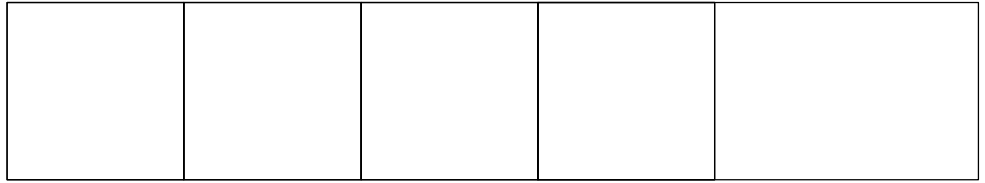

Tighten all screw bolts 100%

100%

STEP 13

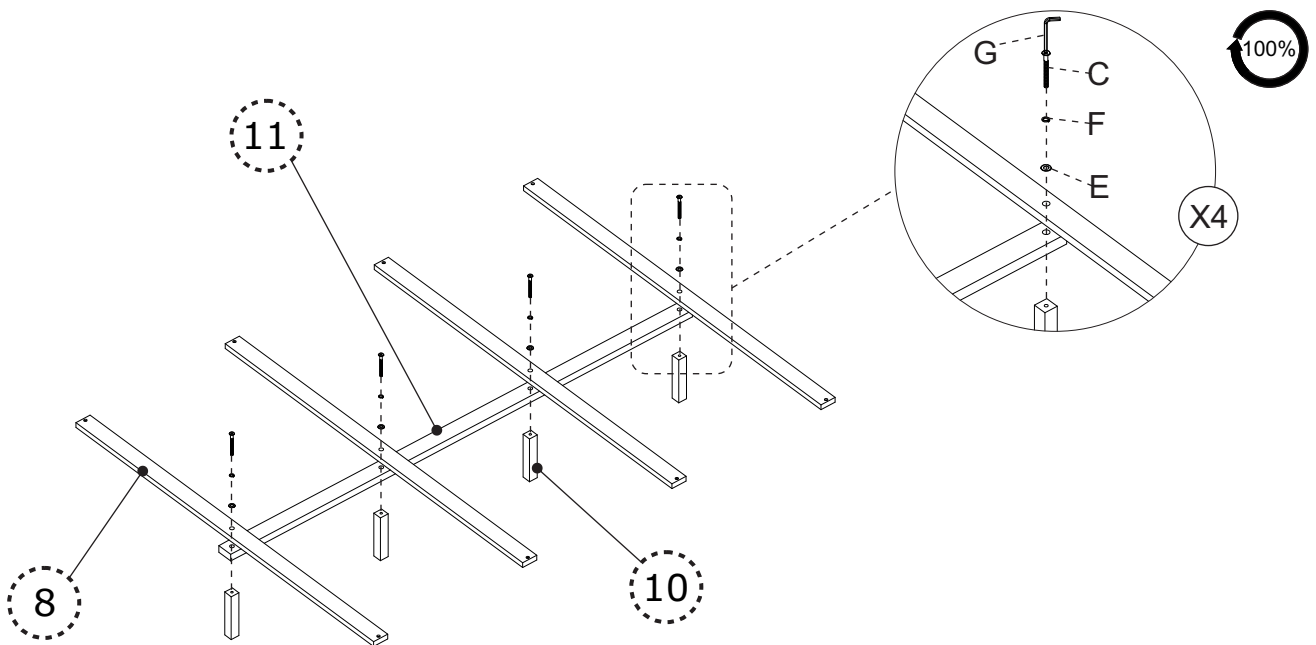
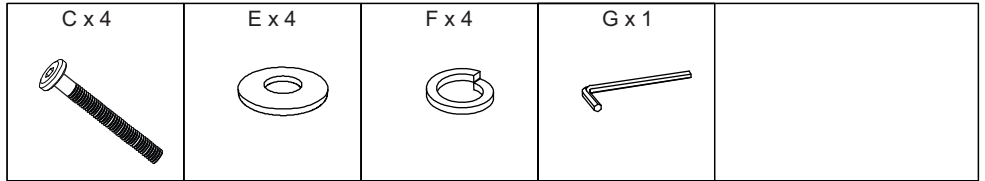

STEP 14

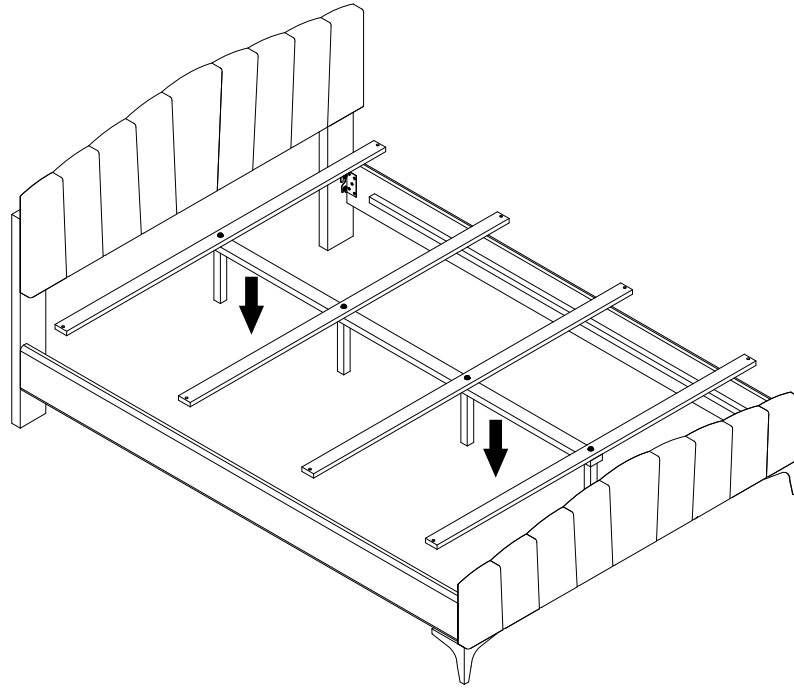
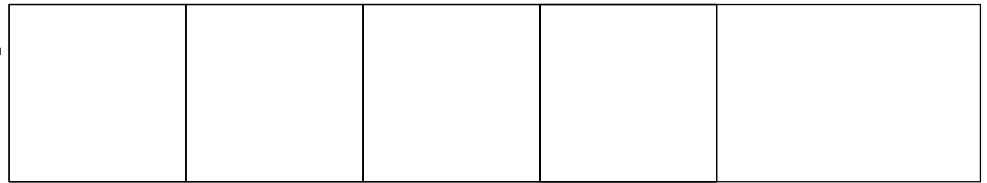

STEP 15

