

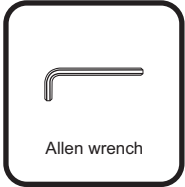

BED DRAWER

ASSEMBLY INSTRUCTIONS

Before assembling your bed drawer, please read through these instructions carefully, familiarize yourself with the different parts.



Allen wrench

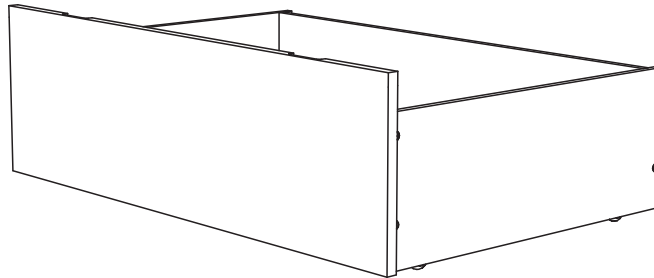

Adult assembly

NOTE : WE INCLUDE SPARE HARDWARE IN CASE DAMAGE OCCURS DURING ASSEMBLY.

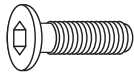

HARDWARE



A JCB M6 X 1 1/8" (30mm) - 16 pcs
Spare - 2 pcs

B Allen wrench - 1 pc
Spare - 1 pc

PARTS LIST

- 01** HARDWARE 1 BOX
- 02** DRAWER FACE 2 PCS
- 03** DRAWER SIDE 4 PCS
- 04** DRAWER BACK 2 PCS
- 05** DRAWER BOTTOM 2 PCS

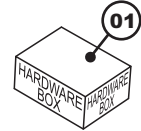
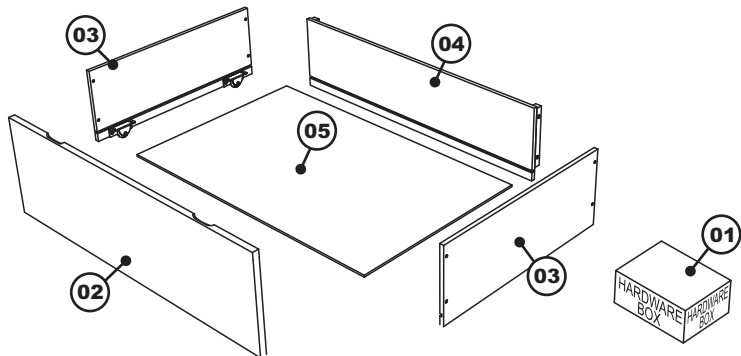

Step 1

Lay the drawer face (02) on smooth, flat surface so the groove is facing upwards. Fit the drawer side (03) to drawer face (02), Use JCB M6 X 1" (A), align groove inside panel with groove in drawer face. Tighten with Allen wrench (B).

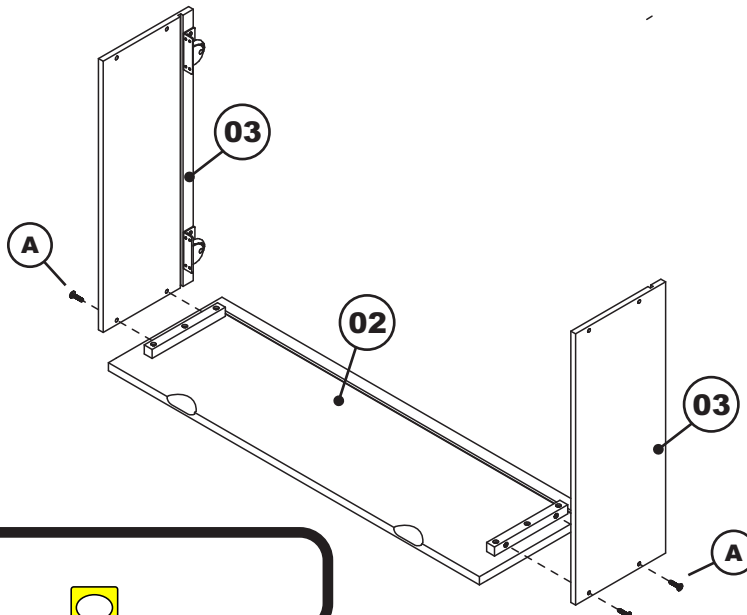

Adult assembly

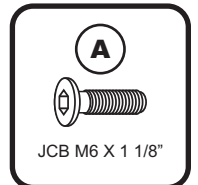

JCB M6 X 1 1/8"

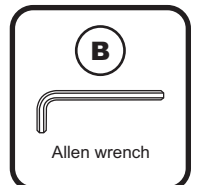

Allen wrench

PO :





BED DRAWER

Step 2

Guide the drawer bottom (05) in carefully so that it won't jump out of its grooves. Be sure it fits fully into its groove at the bottom (in the drawer face) before fitting the drawer back.

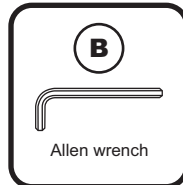
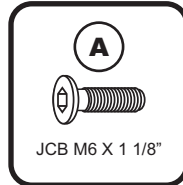

Step 3

Attach drawer back (04) to bed drawer assembly as shown. Use JCB M6 X 1"(A). Tighten with Allen wrench (B).

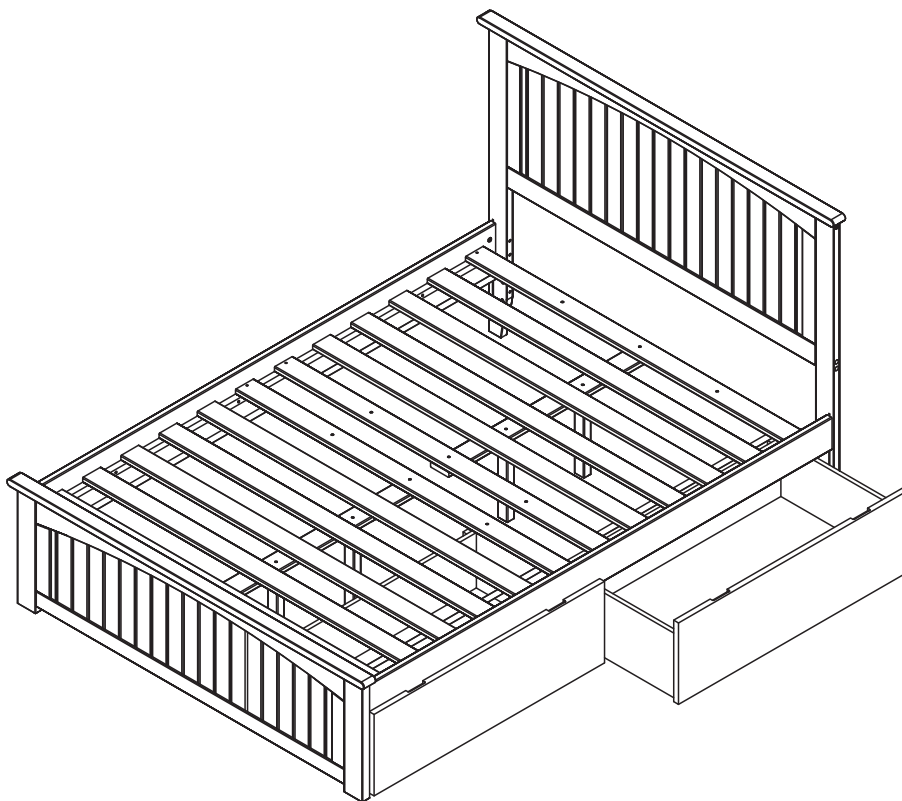
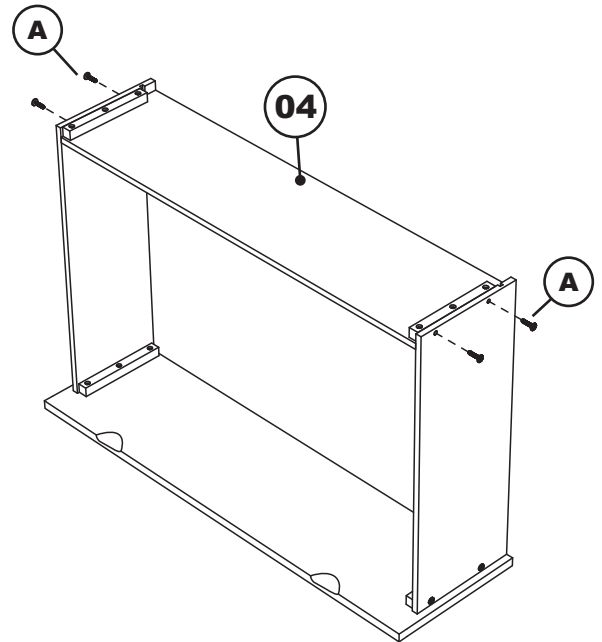

Congratulations!

Your bed drawers are now ready for use. We recommend that you recheck that all screws are tight