

Assembly Instructions

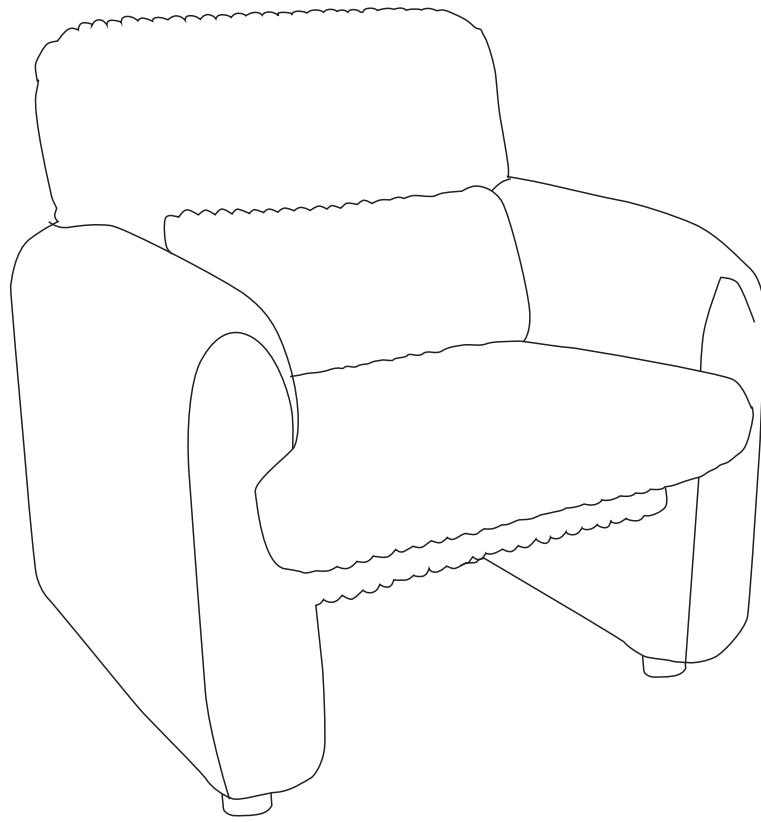

Seat Frame

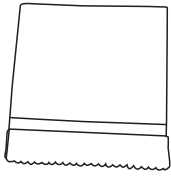

1pc

Right Armrest

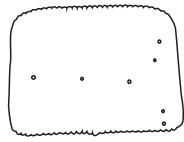

1pc

Left Armrest

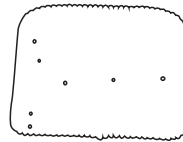

1pc

Back Frame

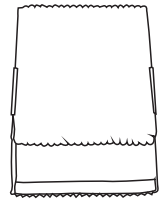

1pc

Seat Cushion

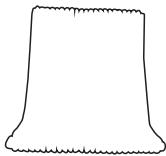

1pc

Backrest Cushion



1pc

Lumbar Pillow



1pc

Metal Connecting Rod



2pcs

Legs

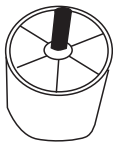

4pcs

Metal Insert

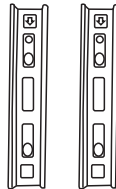

2pcs

Felt Pad



4pcs

A

Flat Washer



6pcs

B

Spring Washer



6pcs

C

Washer



4pcs

D

Wrench



1pc

F

M8x50mm



6pcs

E

M6x25mm



8pcs

STEP 1: Use screw (E) to assemble the metal insert onto both sides of the armrests.

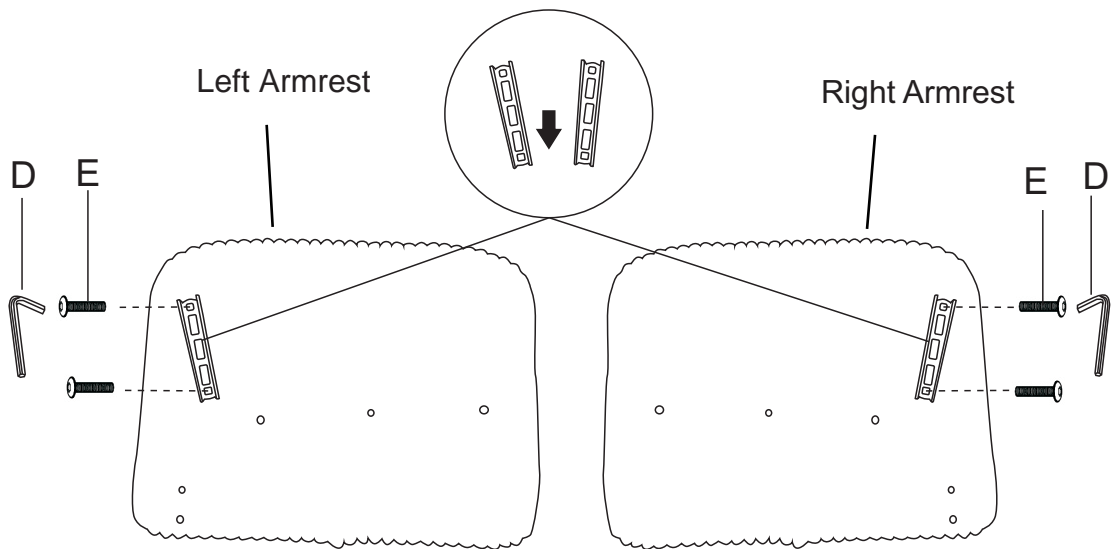

Step 2: Align the seat frame with the armrests using washers (A, B) with screws (F)
Tighten the screws (approximately 70–80%) without fully locking them.

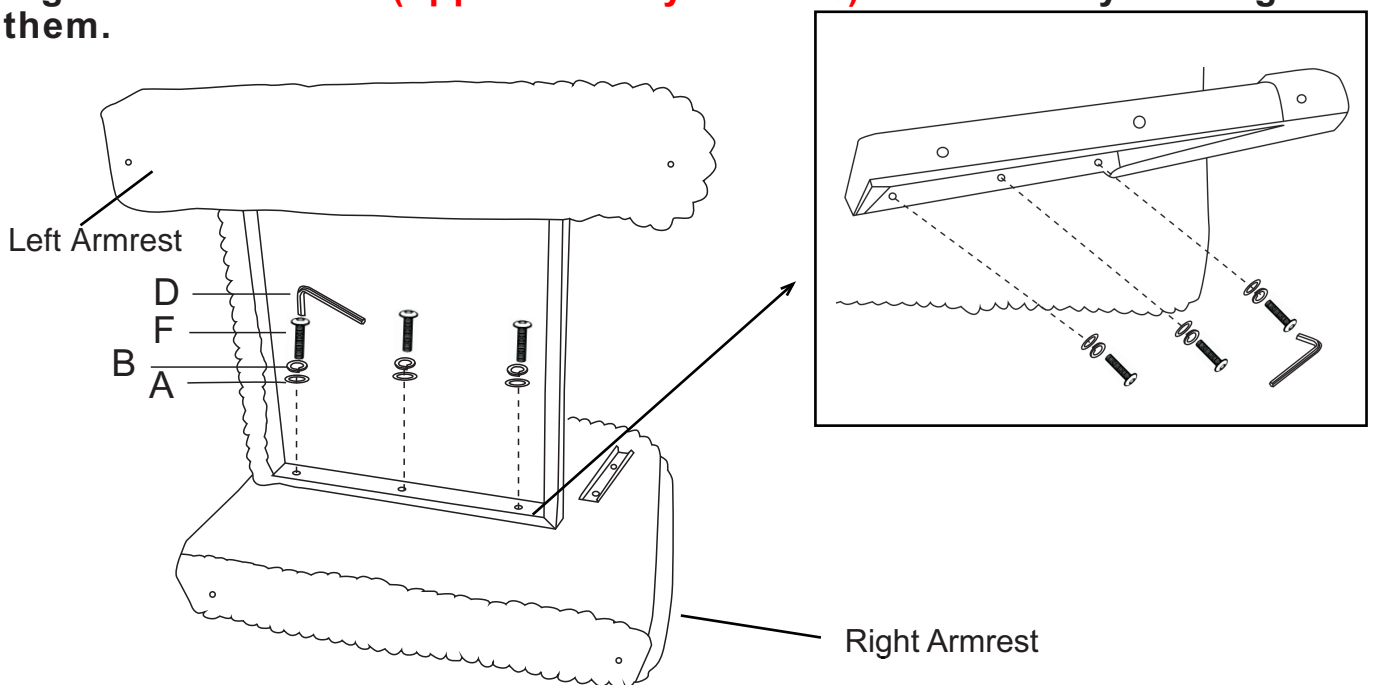

Step 3: Attach the metal crossbar between the two armrests under using screw (E), ensuring it is firmly secured.

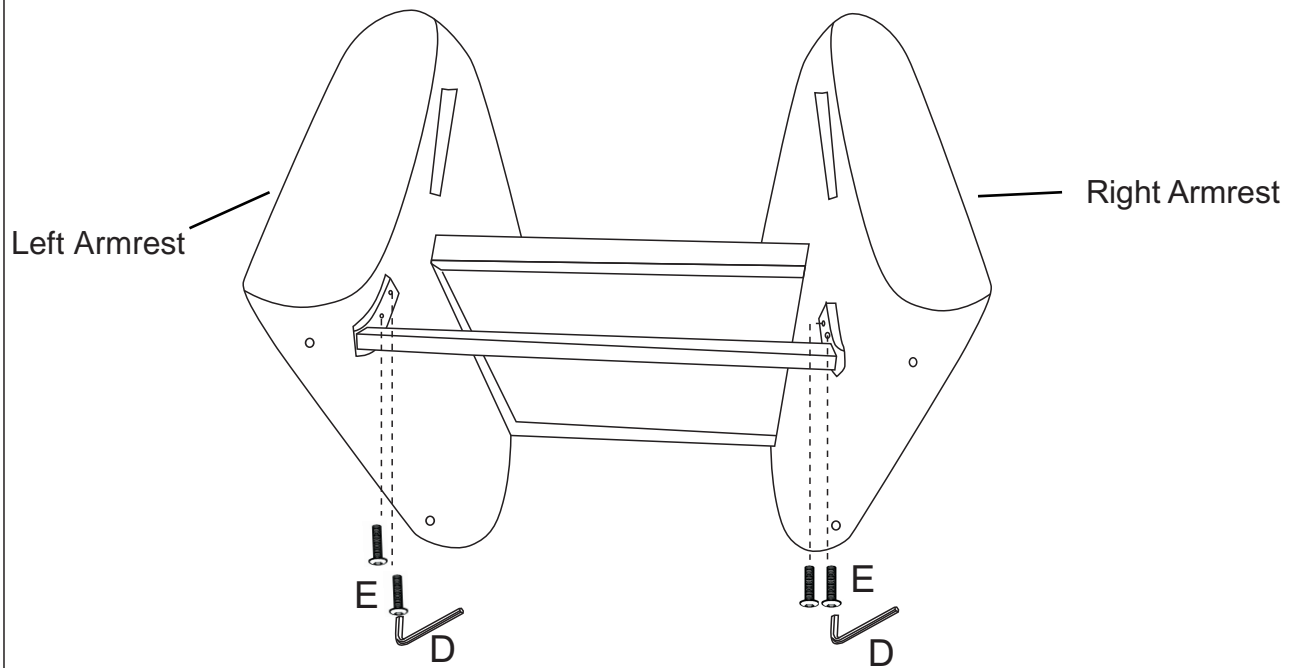

Step 4: Align the metal insert on both the backrest and armrests, insert them into position, and secure them firmly

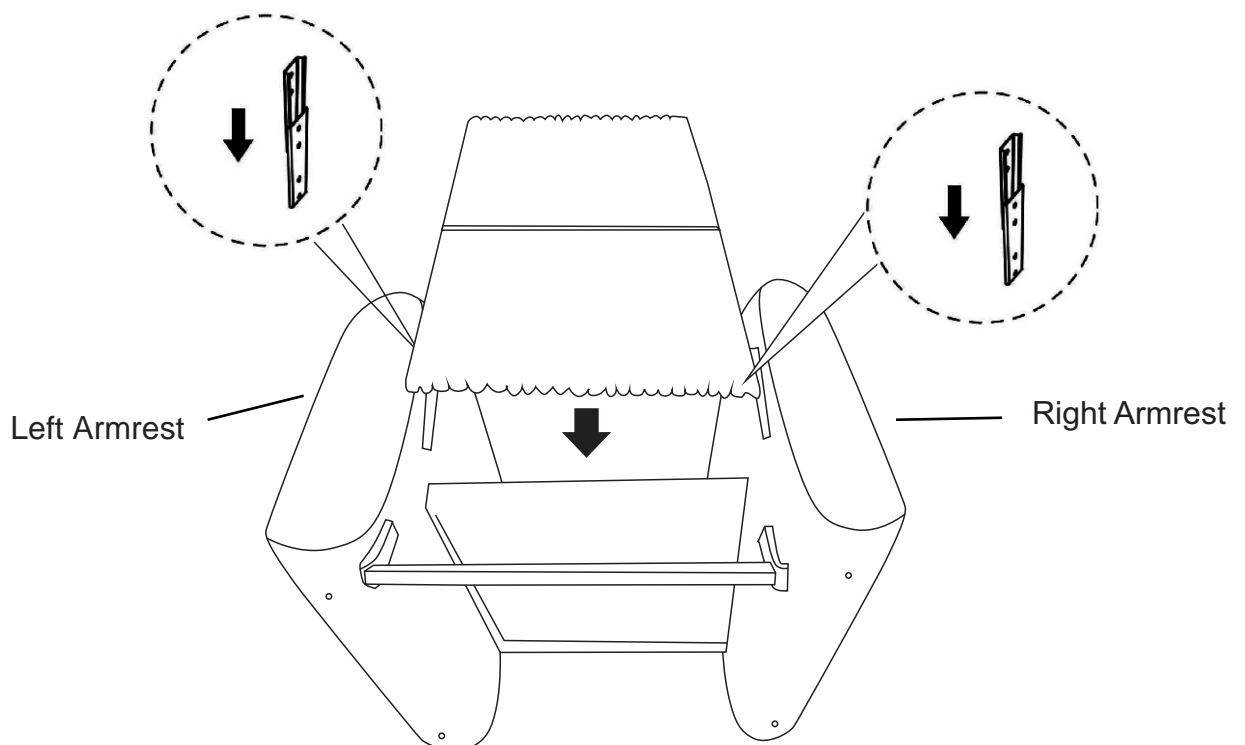

Step 5: Stretch the backrest fabric tightly and adhere it to the metal crossbar to ensure a smooth, secure fit.

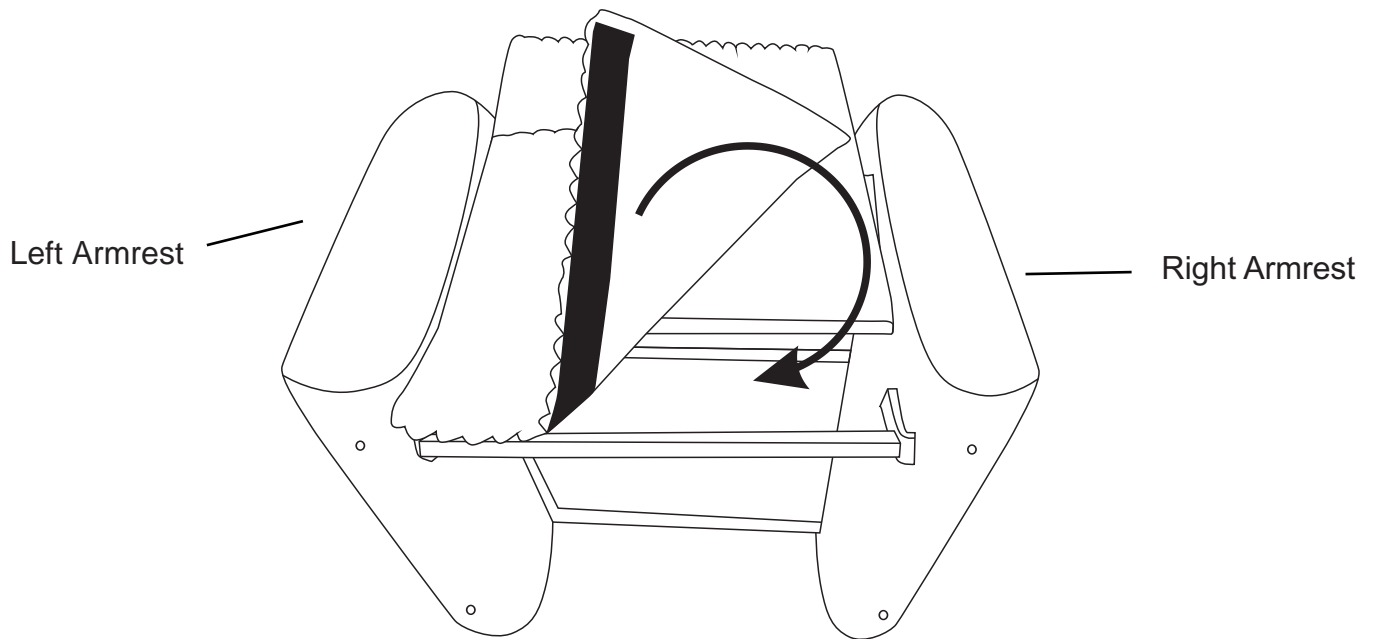

 Once everything is aligned nicely, go back and **fully tighten them**. This makes the assembly easier and safer!

Step 6: Use washers (C) to securely tighten the legs

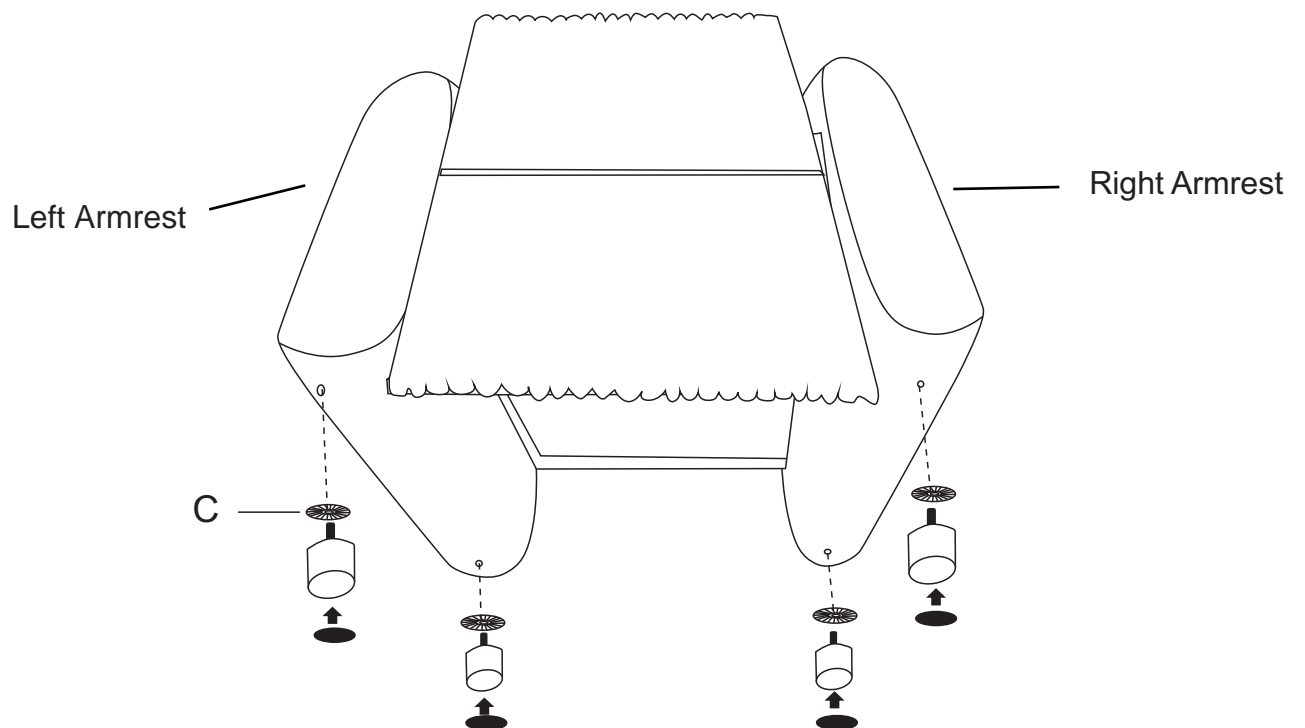

Step 7: Place the seat cushion, backrest cushion, and lumbar pillow onto the chair to complete the assembly.

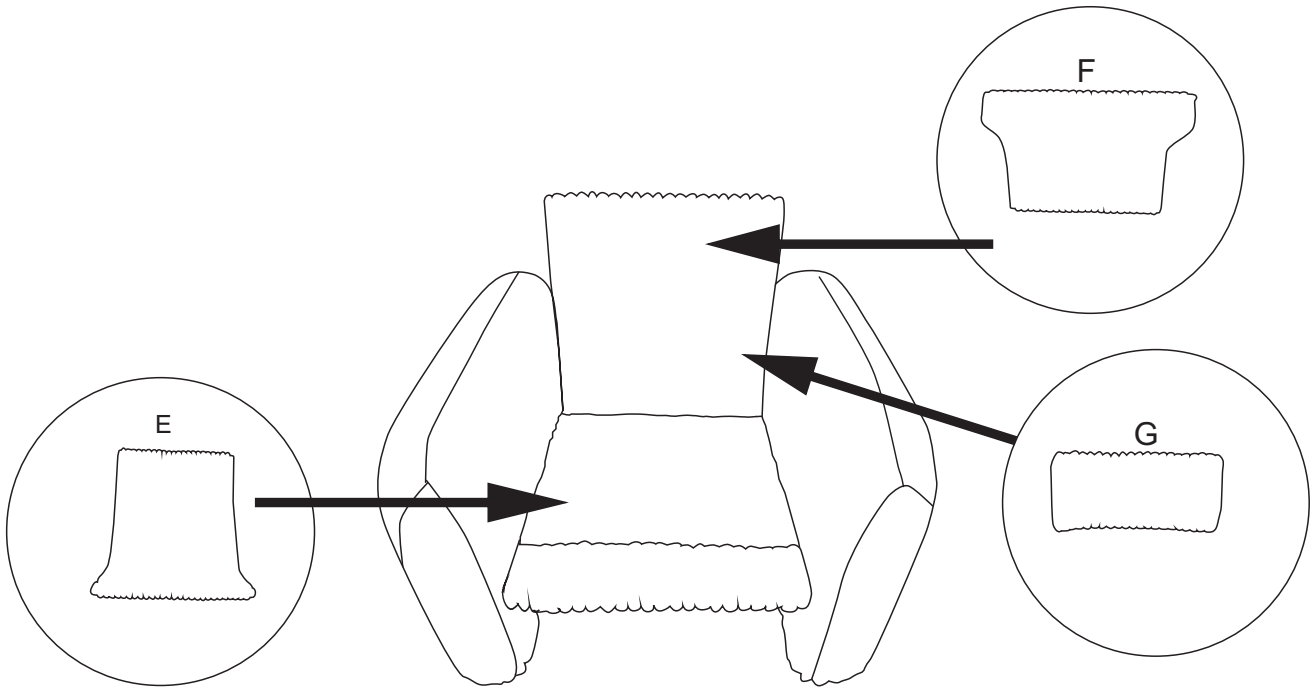

Assembly Completed

