

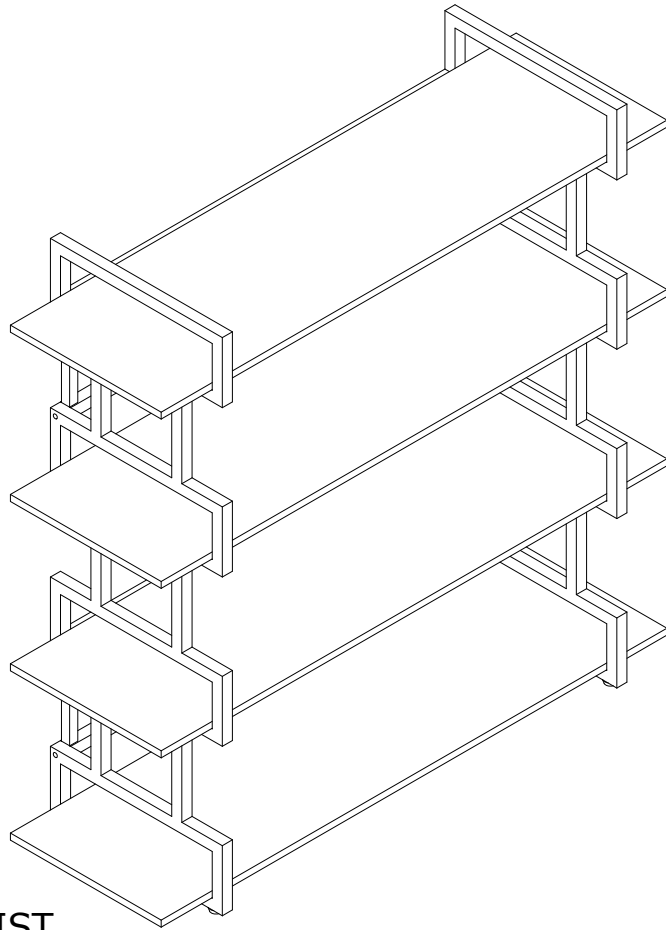

# ASSEMBLY INSTRUCTIONS

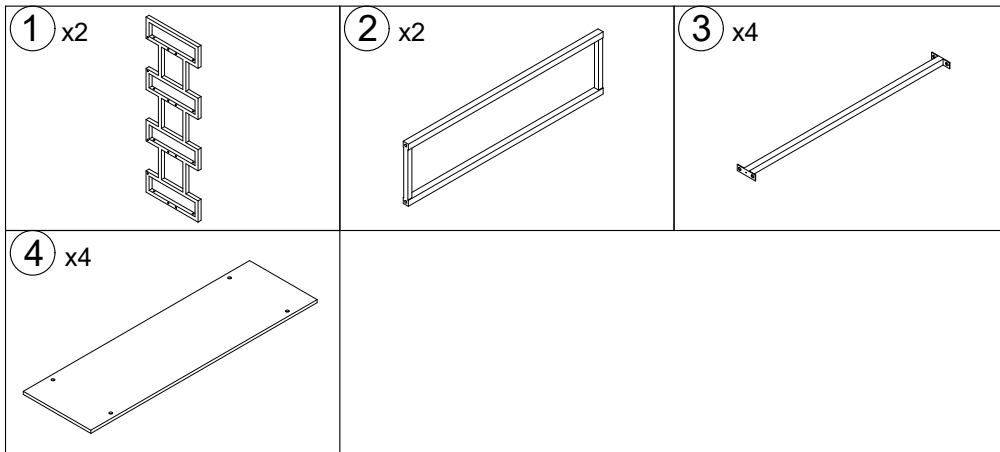

## PARTS LIST

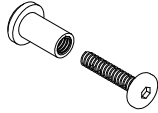
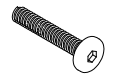

## HARDWARE LIST

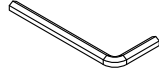
<p>A x16</p>  <p>1/4 X 1/2</p>	<p>B x24</p>  <p>1/4 X 1-1/8</p>	<p>C x4</p> 	<p>D x1</p> 
---	---	---	---

When the process of product assembly, please do not lock the screws at one time, but wait until all the screws are assembled to the position, and then straighten and flatten the product, and then tighten the screws of the same height in turn, so as to avoid unsmooth assembly and product tilt.

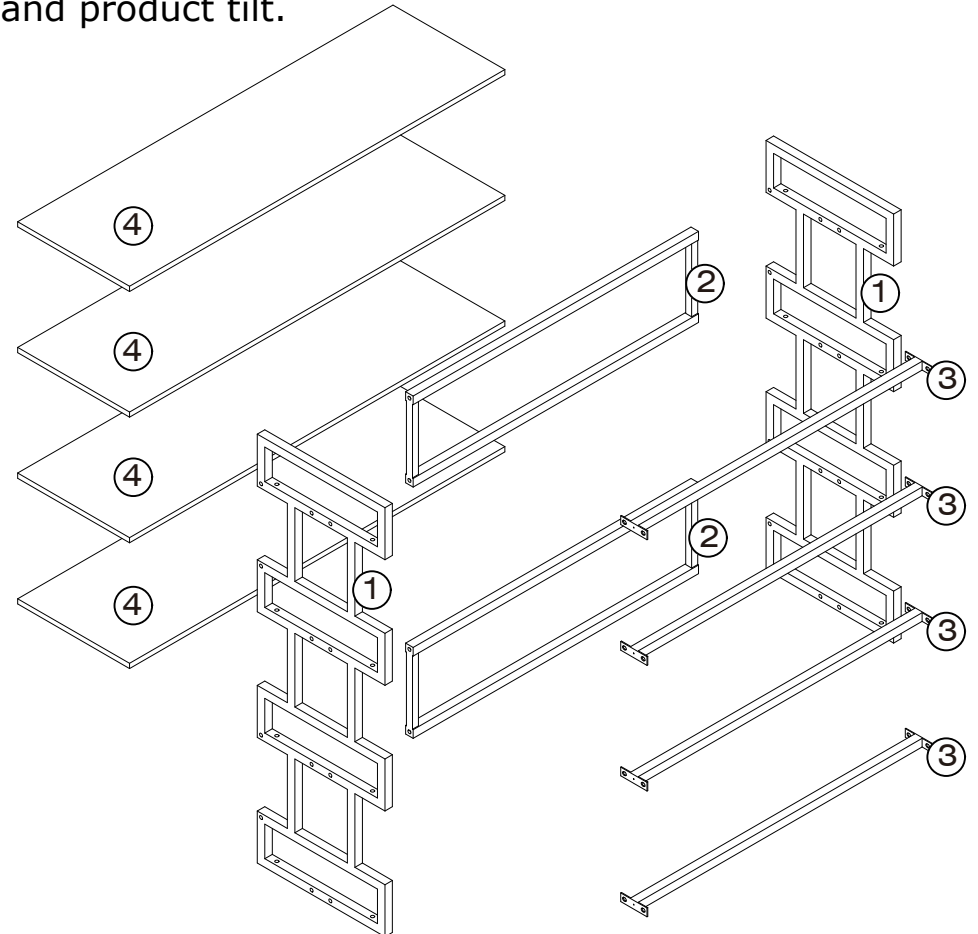

# ASSEMBLY INSTRUCTIONS

## STEP 1

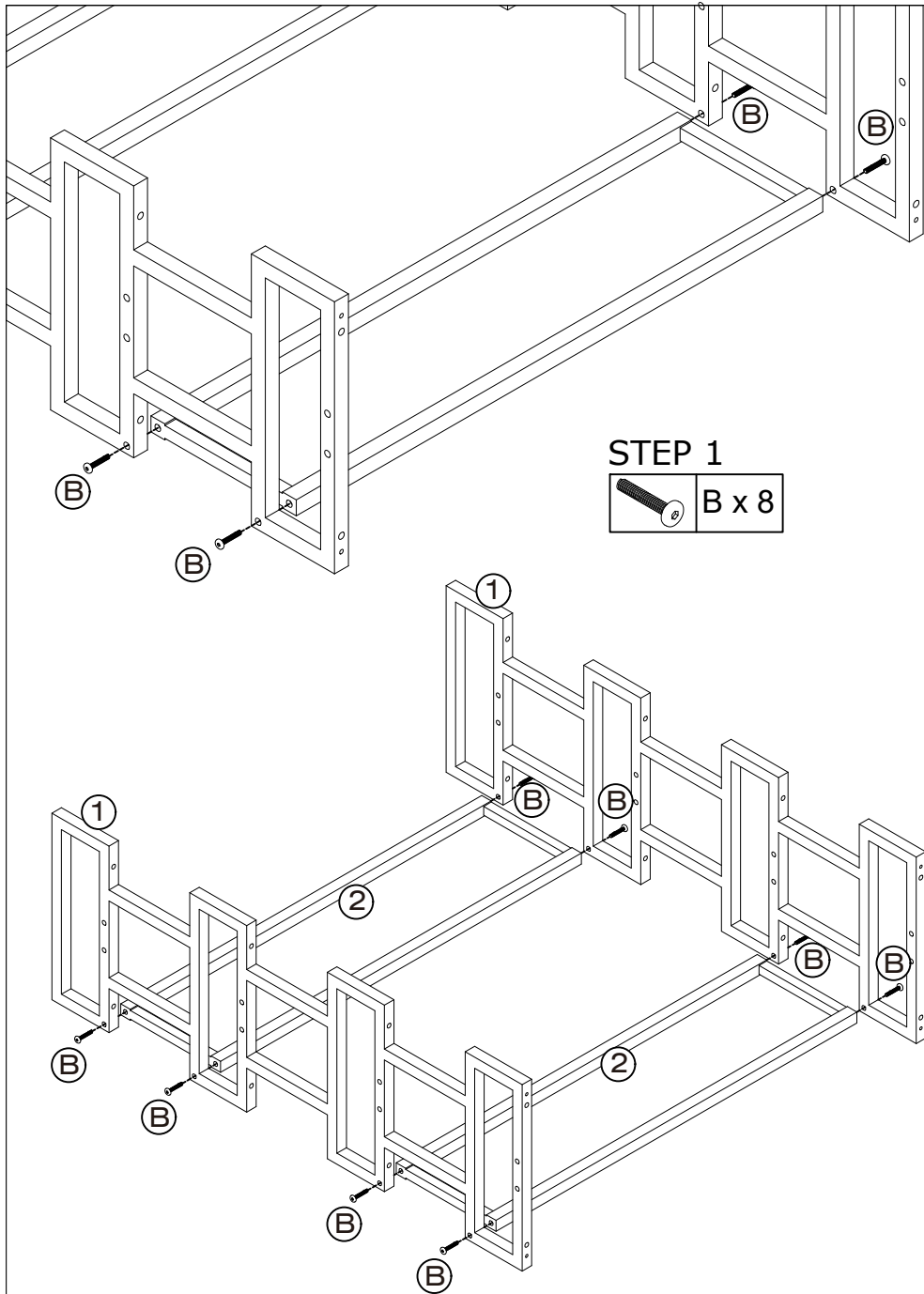
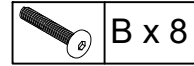

## STEP 2

