

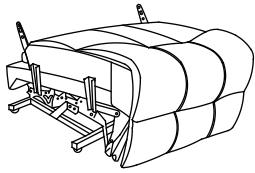

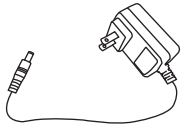



# INSTRUCTION MANUAL

# PACKING DETAILS: TOTAL 3 BOXES

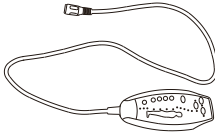
## BOX-1/3

NO.	PARTS	QTY
<b>A</b>		<b>1</b>
<b>H</b>		<b>1</b>
<b>J</b>		<b>2</b>

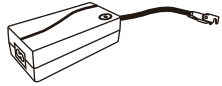
NO.	PARTS	QTY
<b>G</b>		<b>1</b>
<b>X</b>		<b>1</b>
<b>K</b>		<b>4</b>

NO.	PARTS	QTY
<b>I</b>		<b>1</b>
<b>L</b>		<b>4</b>

## BOX-2/3

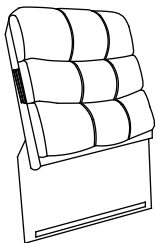
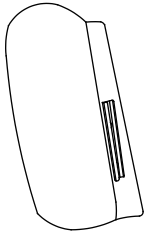
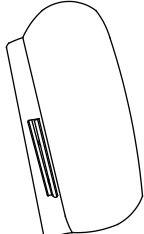
NO.	PARTS	QTY
<b>B</b>		<b>1</b>
<b>P</b>	 P(R)	<b>1</b>
<b>P</b>	 P(L)	<b>1</b>

## BOX-3/3

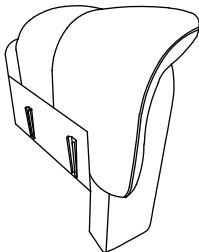
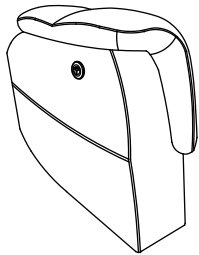
NO.	PARTS	QTY
<b>F</b>	 F(L)	<b>1</b>
<b>F</b>	 F(R)	<b>1</b>

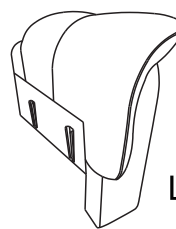
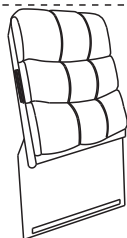
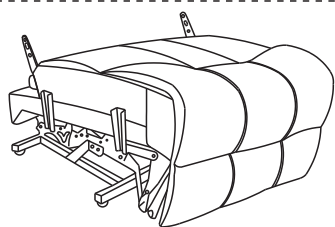

L

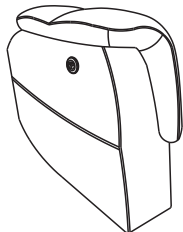

R

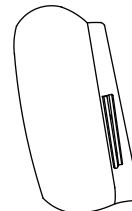
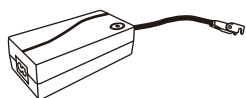
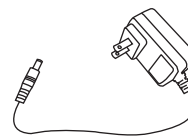
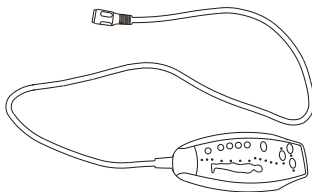

R

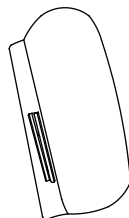

L

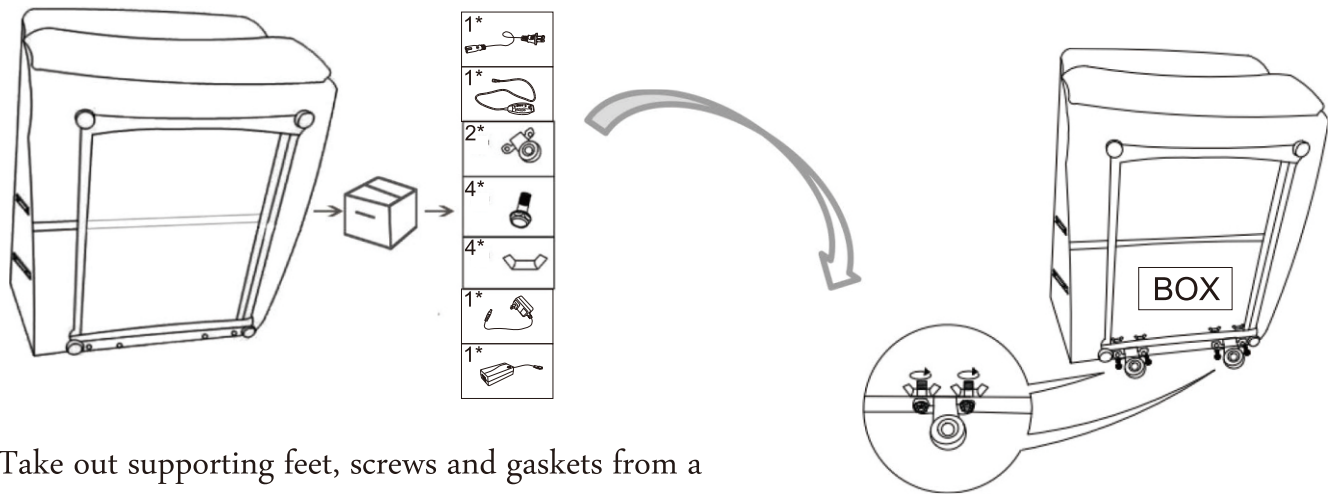

Take out supporting feet, screws and gaskets from a small plastic bag packed in the box. Assemble the two supporting feet as shown on the bottom of mechanism to avoid toppling and falling. (PS: The transformer, power cords and remote control are also in this box!)

Nehmen Sie Stützfüße, Schrauben und Dichtungen aus einer kleinen Plastiktüte heraus, die in der Box verpackt ist. Montieren Sie die beiden Stützfüße, wie auf der Unterseite des Mechanismus gezeigt, um Sturz und Fall zu vermeiden (PS: The transformer, Netz kabel und Fernbedienung sind auch in dieser Box!)

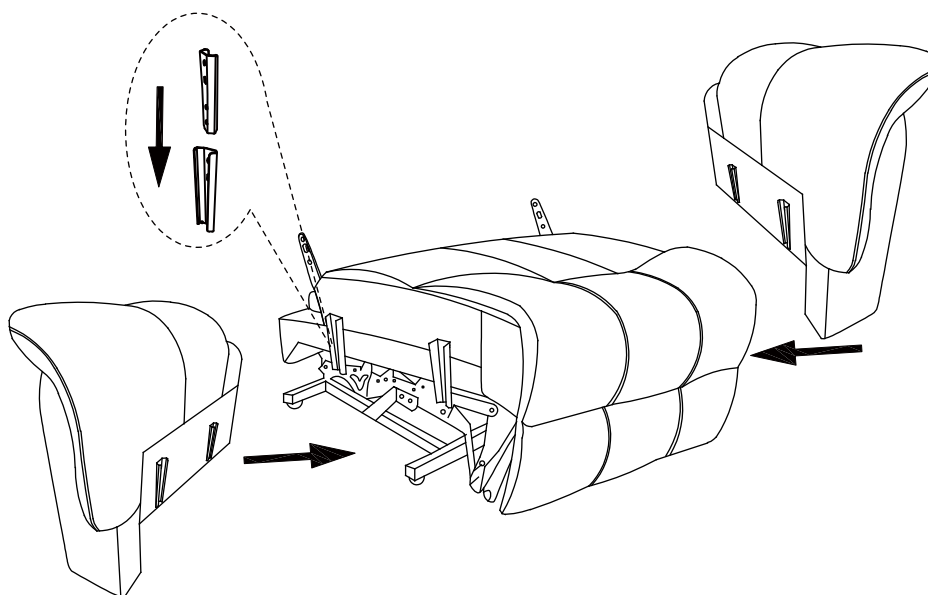
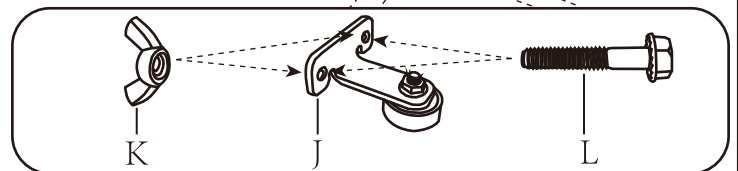
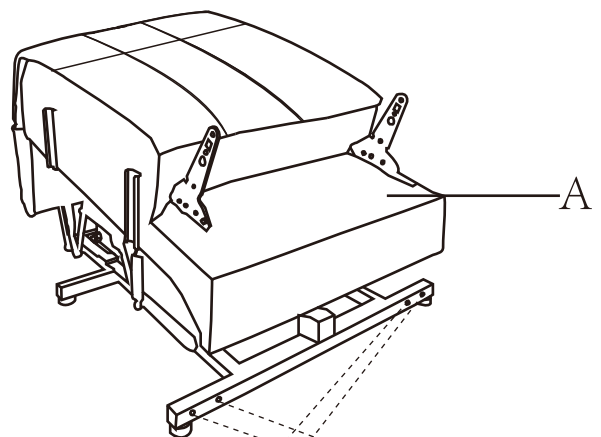

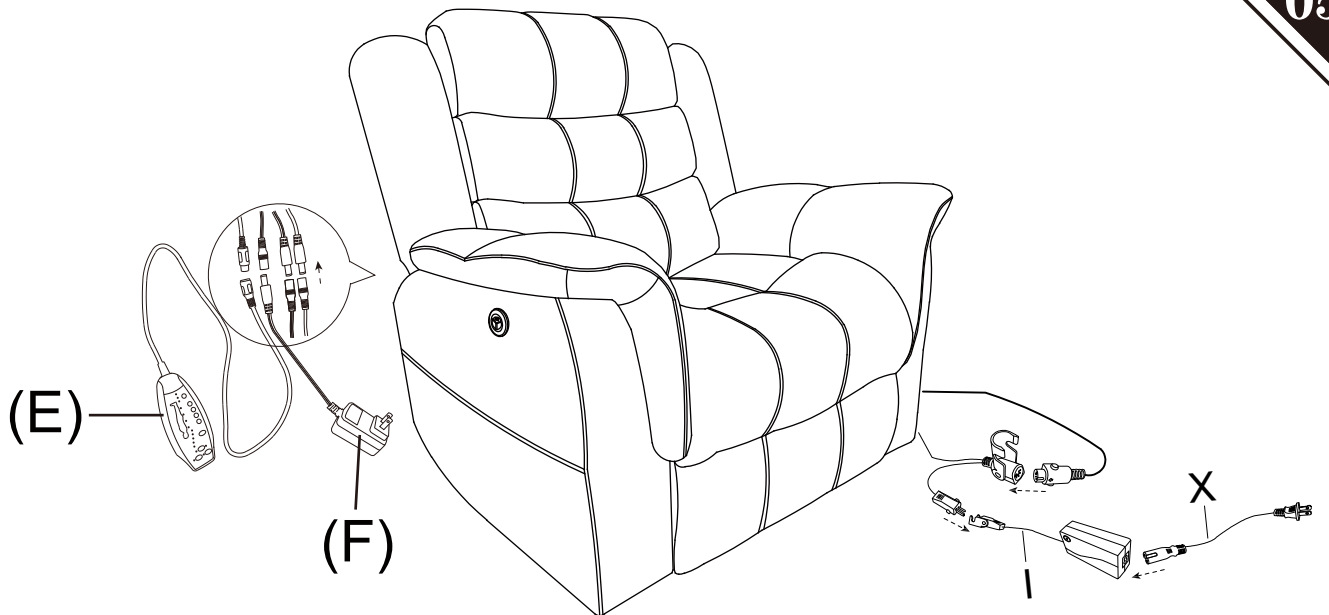
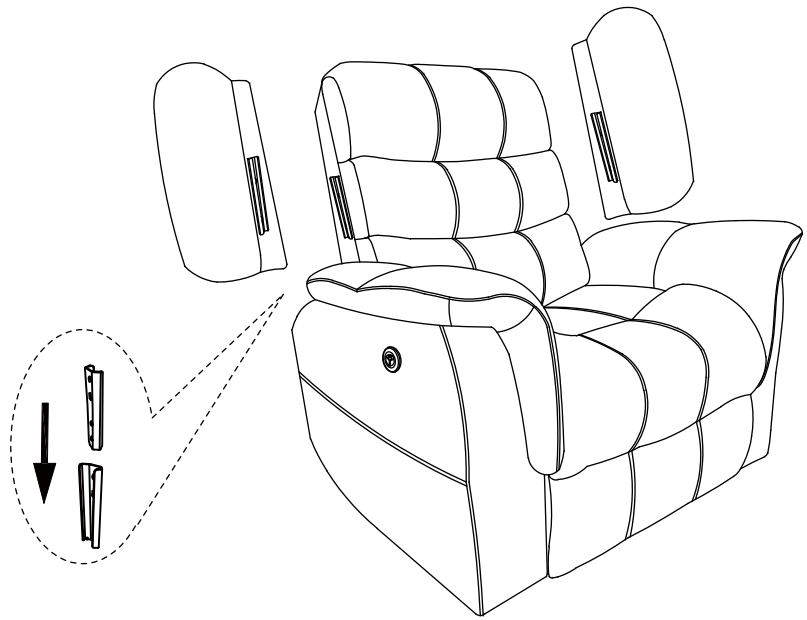
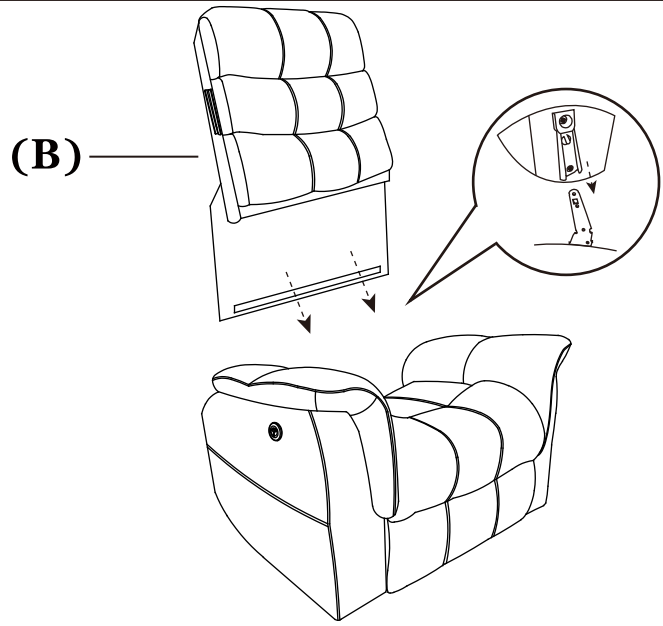

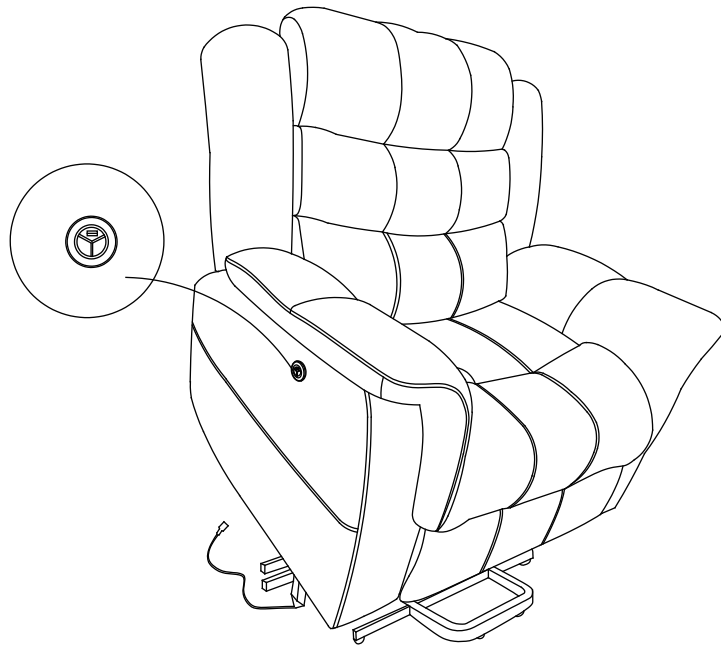
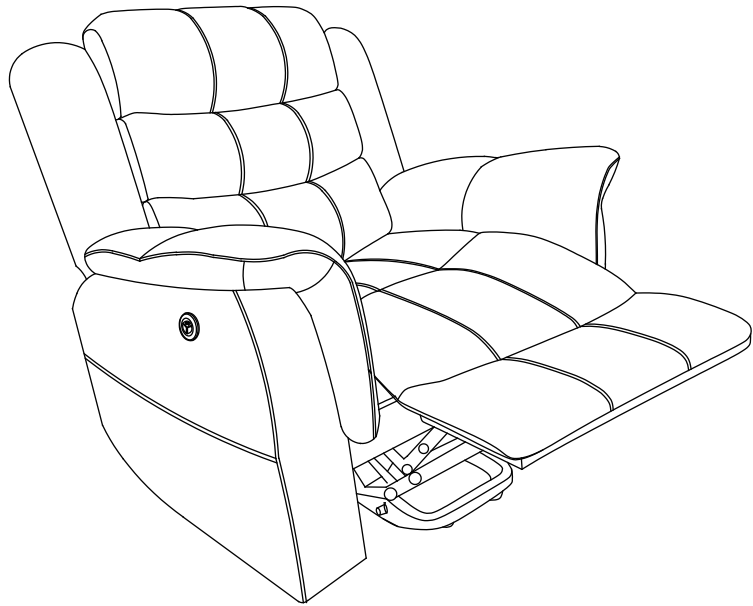

# Remote Operation Instruction

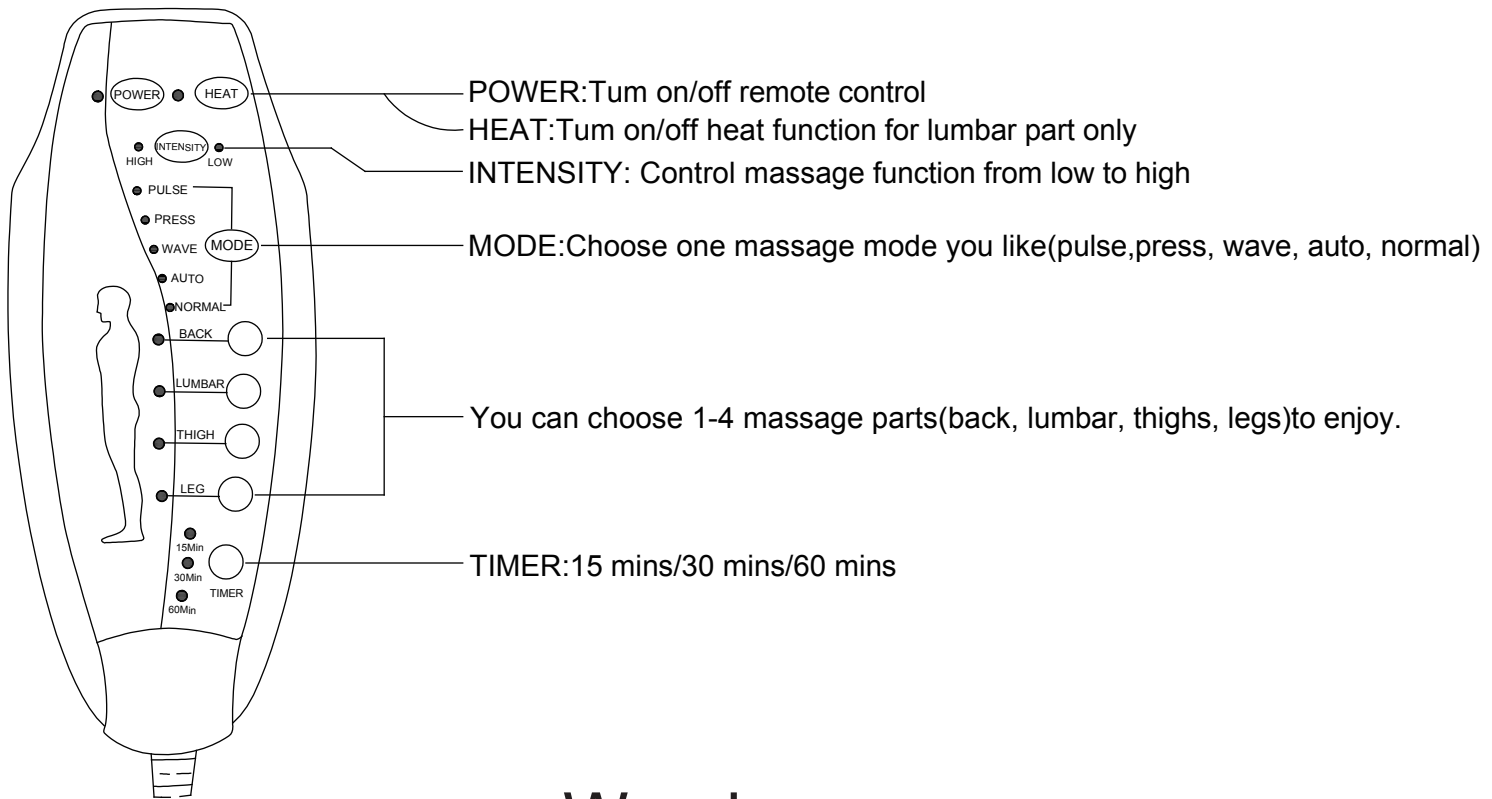

## Warning

1. Please check if the components of the chair are all included and can be used normally as the 6th tip.
2. Assemble all components according to the instruction correctly before you connect the chair with the power.
3. Please DO NOT sit on the armrests or footrest to eliminate the risk of tipping over.
4. Please use carefully to avoid sliding from the chair when lifting.
5. If the sofa is damaged or doesn't match the website product, please send clear pictures of the product and label of the carton to our service team, and we will help you to solve the problem.
6. If the lift recliner doesn't work, you can try the following measures for self-checking firstly:
  - ① Check if all the cables are connected;
  - ② Check if the light of transformer is on.
  - ③ If the motor has a weak buzz on condition that two steps above are normal. If the chair still doesn't work, please feed the information back to the customer service in time. We will help solve the problem for you as soon as possible.