

AI - VSC48WD8D

Assembly Instructions

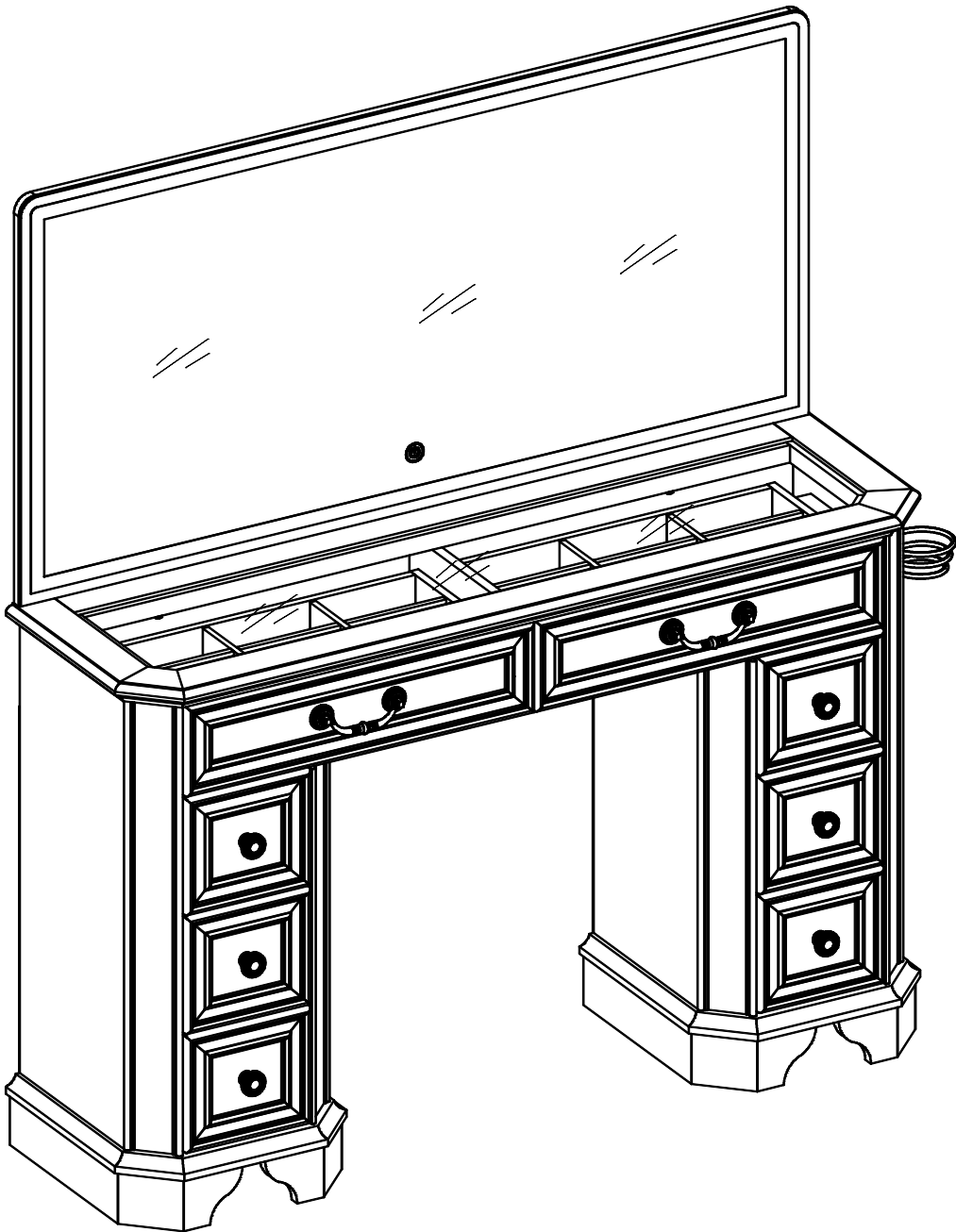

Date 2025-04-15 Rev.01-A

General Assembly Guidelines

- I. Ensure that all parts and hardware are available before beginning assembly.
- II. Follow each step carefully to ensure the proper assembly of this product.
- III. Two people are recommended for ease in the assembly of this product.
- IV. A Phillips head screwdriver is required for the assembly of this product .

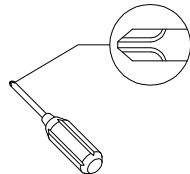

- V. The provided glue is to secure wood dowels in place . When first inserting dowels , locate the appropriate hole for the dowel , place a small amount of glue in the hole and insert the dowel . Wipe away excess glue immediately.

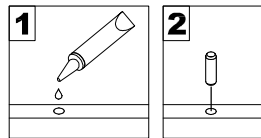

In future assembly steps when dowels are necessary to attach assembly parts together , place a small amount of glue on the end of the dowel before attaching parts together . Wipe away excess glue immediately.

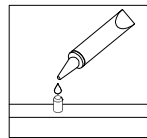

VI HOW THE KNOCK DOWN (KD) ASSEMBLY SYSTEM WORKS

- 1.Screw the Cam Bolt into the pre-drilled hole on the panel. Make sure Cam Bolt goes into the pre-drilled hole on the end of panel for Cam Lock.
- 2.Insert the Cam Lock into the pre-drilled large hole on the panel. Make sure the arrow on the face of Cam Lock points towards Cam Bolt.
- 3.Take a Phillips screwdriver and rotate the Cam Lock clockwise to lock the Cam Bolt.
- 4.Use the sticker to conceal the Cam.

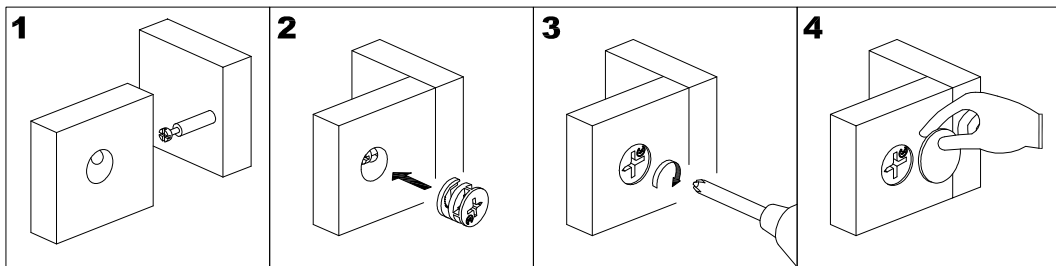



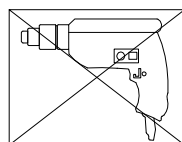



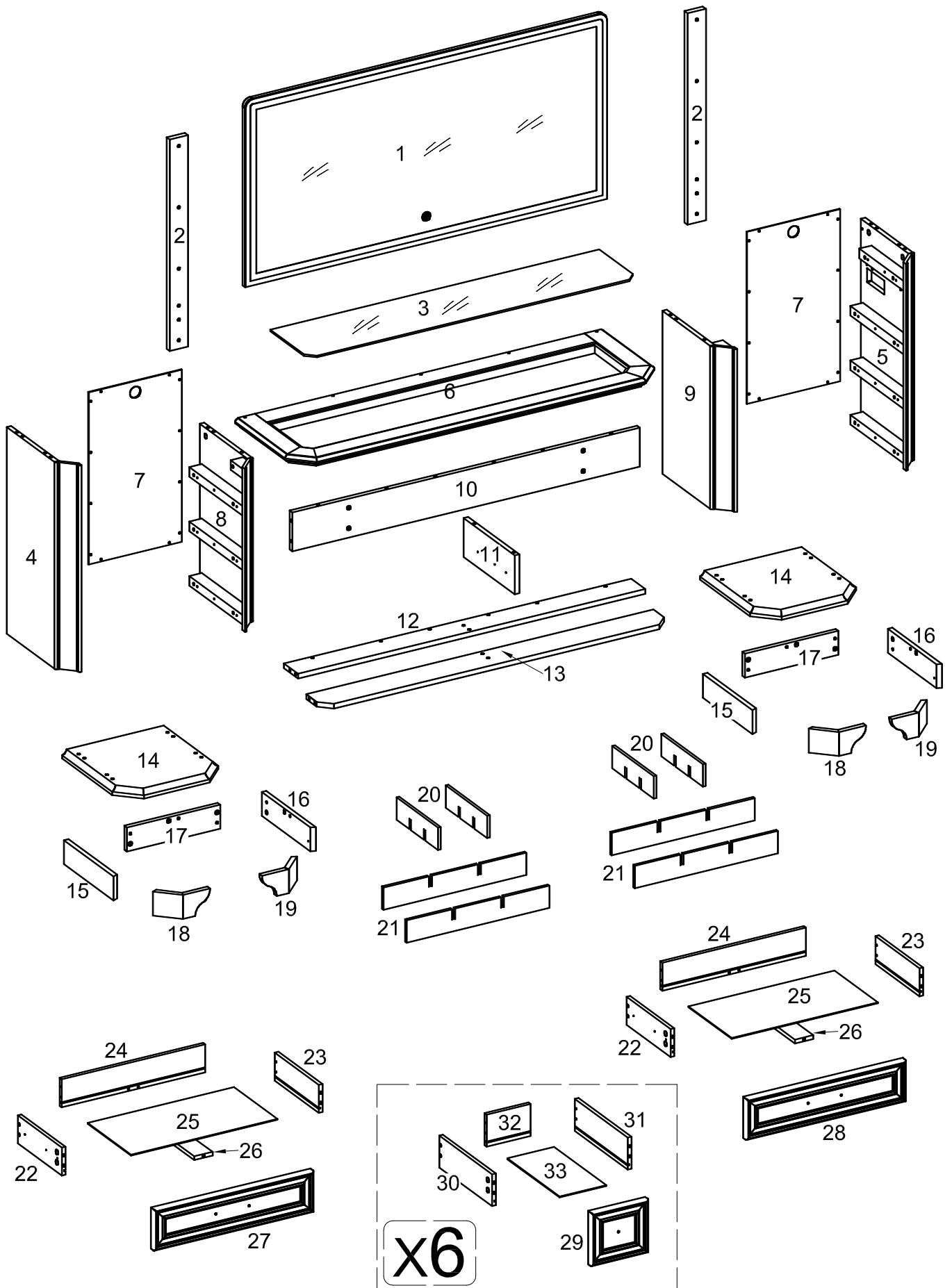



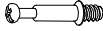

- VII. Power tools should not be used to assemble this product .



Parts List



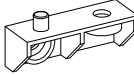

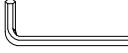
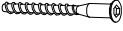
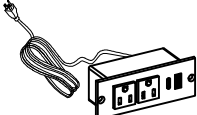

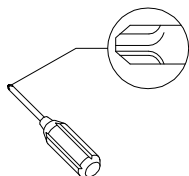





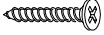

Hardware List

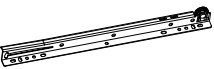
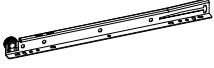
A		Ø8x30mm	Large Dowel	24 pcs
B		Ø6x35mm	Cam Bolt	56 pcs
C		Ø15x11mm	Large Cam Lock	22 pcs
D		Ø30mm	Cam Cover	56 pcs
E			Glue	1 pc
F			L Shape Bracket	4 pcs
G		Ø3.5x12mm	Screw	112 pcs
H		Ø4x12mm	Handle Bolt	10 pcs
J			Handle	2 sets
K			Knob	6 pcs
L		Ø6x30mm	Bolt	10 pcs
M			Connector Block	18 pcs
N		Ø6x14mm	Bolt	36 pcs
P		M 4	Allen Wrench	1 pc
Q		Ø6x50mm	Screw	16 pcs
R			USB Interface	1 pc

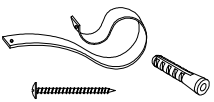

Philips head screwdriver required for assembly
(not included)

Hardware List

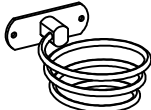
S		Ø4x12mm	Screw	4 pcs
T		Ø15x9mm	Small Cam Lock	34 pcs
U		Ø6x30mm	Small Dowel	5 pcs
V		Ø4x38mm	Screw	36 pcs
W		12"	Left Glide Track	6 pcs
X		12"	Right Glide Track	6 pcs
Y		12"	Left Glide Runner	6 pcs
Z		12"	Right Glide Runner	6 pcs
AA		10" --- 35mm	Drawer Slider	2 sets
BB		Ø13x1mm	Lock Washer	10 pcs
CC		Ø16x1mm	Flat Washer	10 pcs
DD		Ø3.5x15mm	Screw	24 pcs
EE			Metal Plate	3 pcs
FF			Tipping Restraint Hardware	2 sets
GG			Power Plug	1 pc
HH			Hair Dryer Rack	1 pc

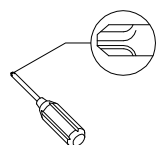

Philips head screwdriver required for assembly
(not included)

Step 1

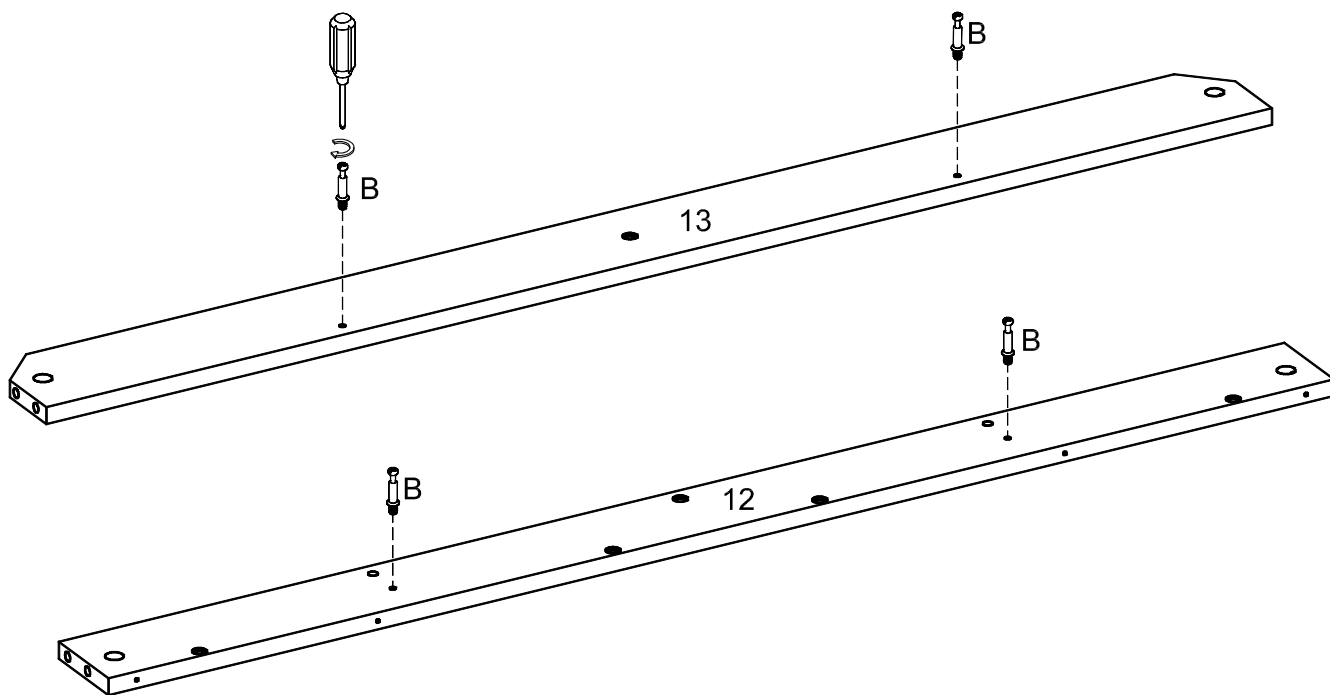

Step 2

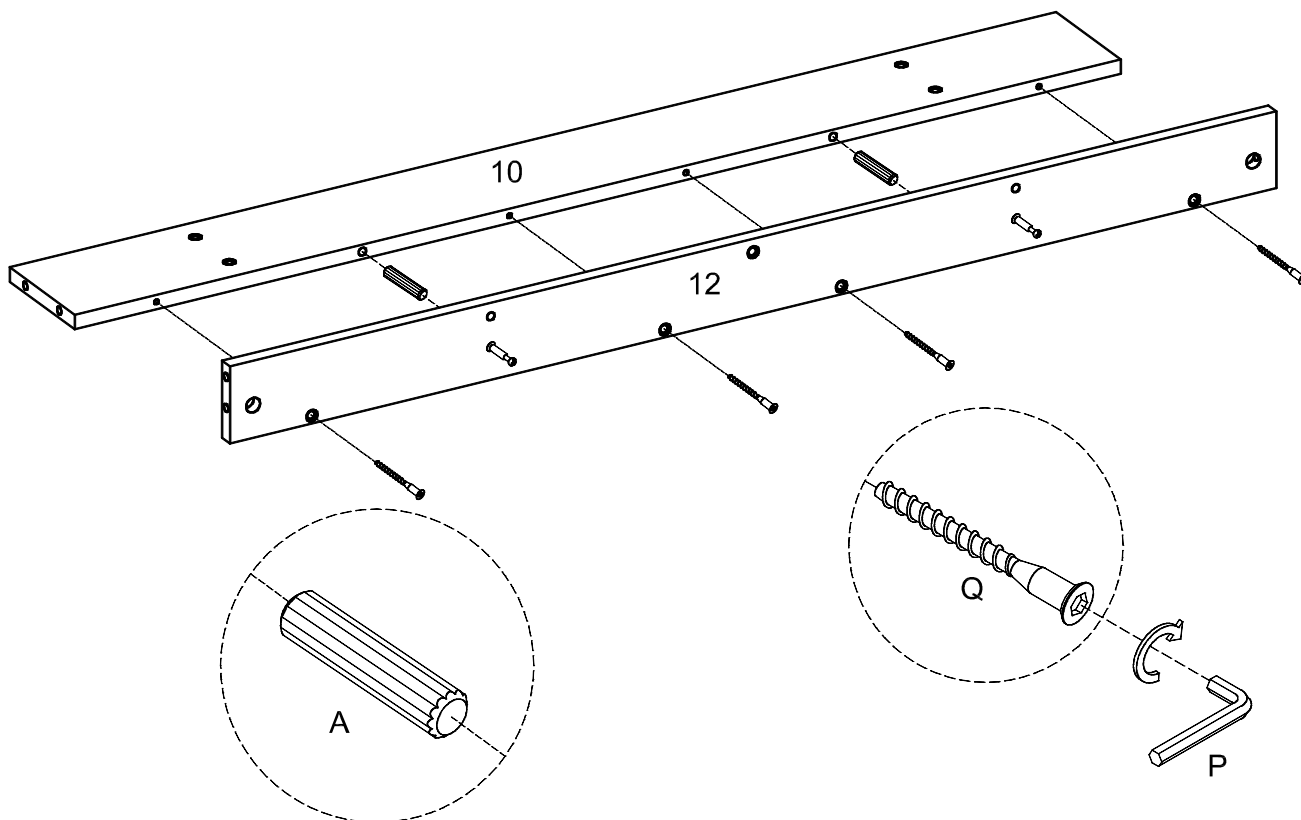

Step 3

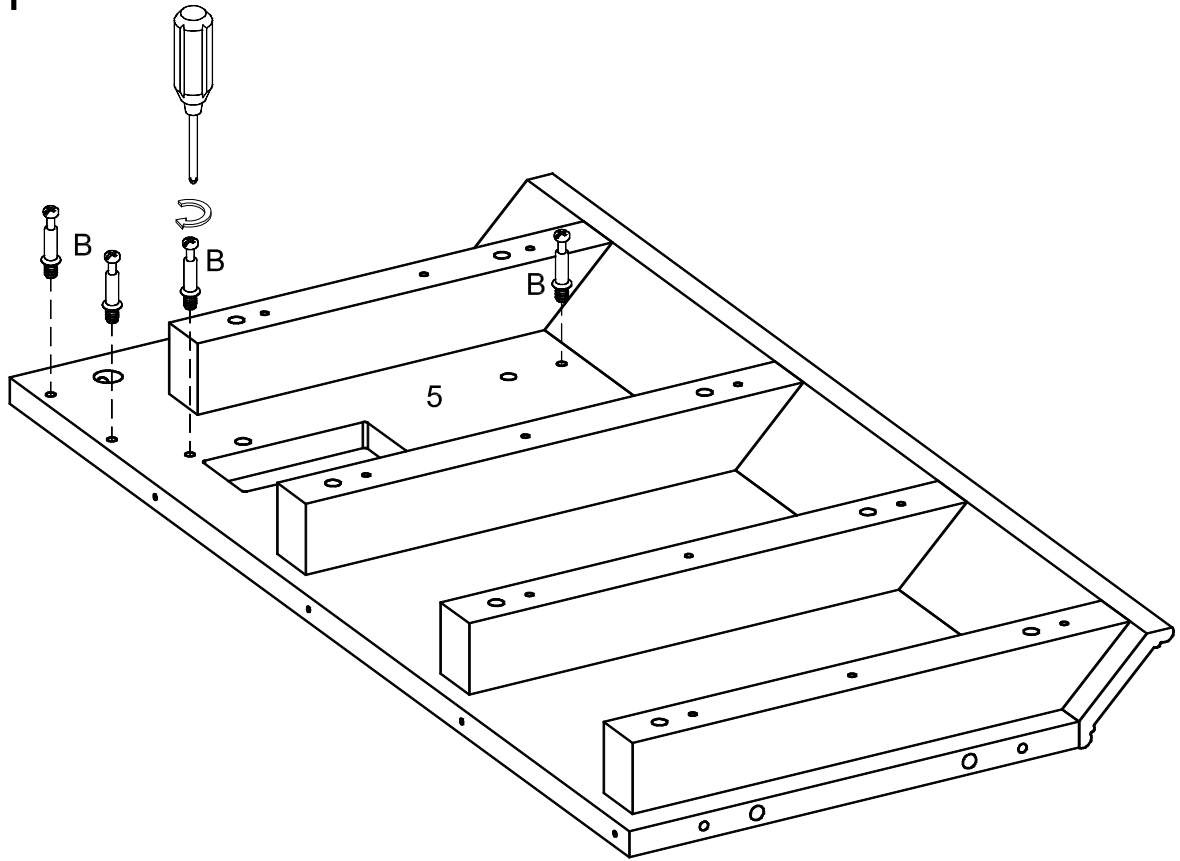

Step 4

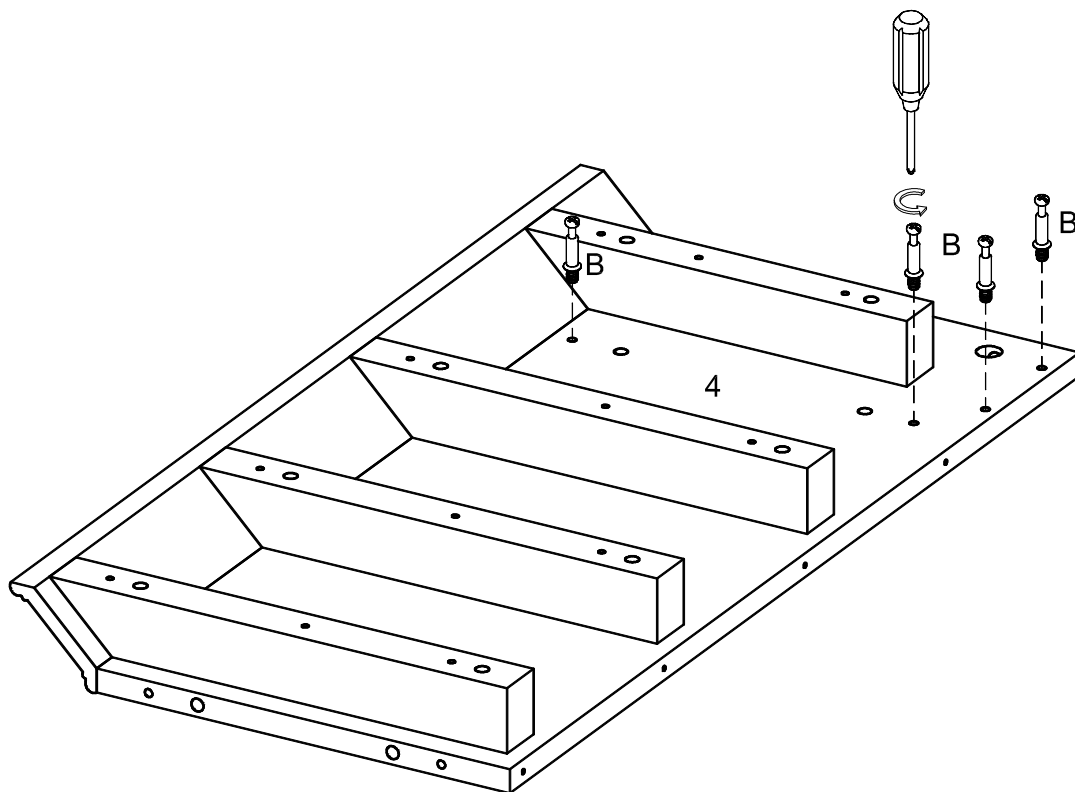

Step 5

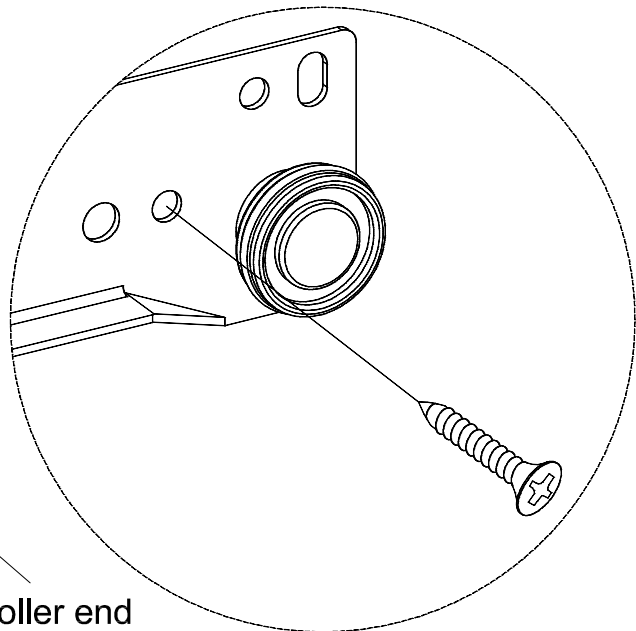
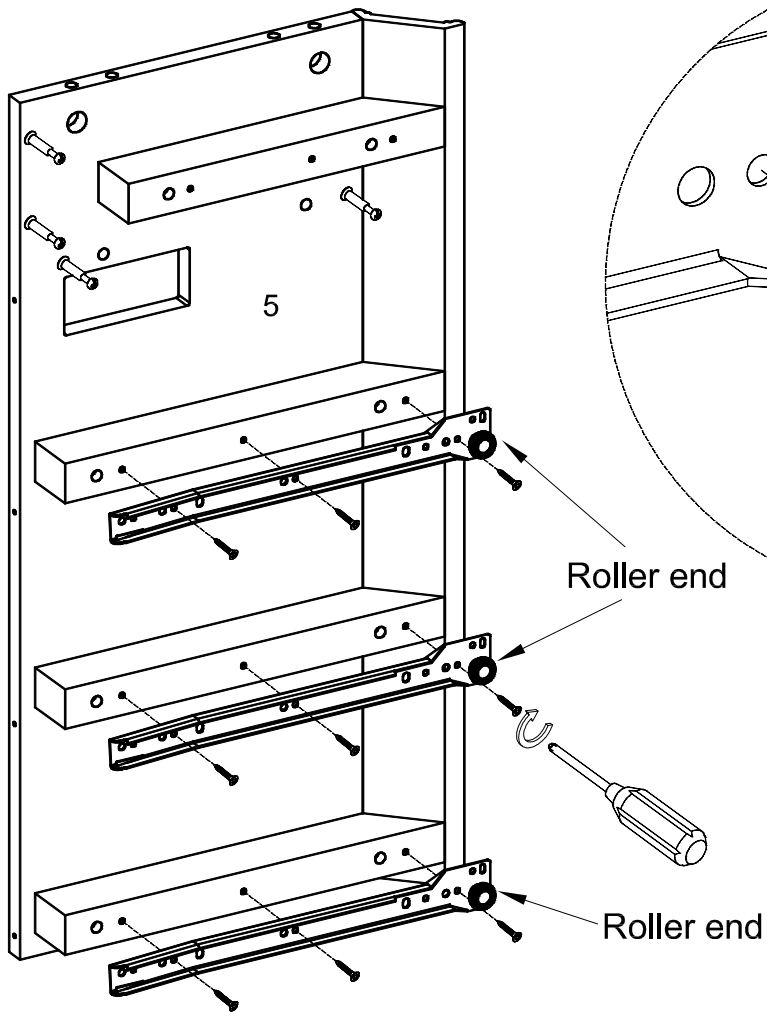
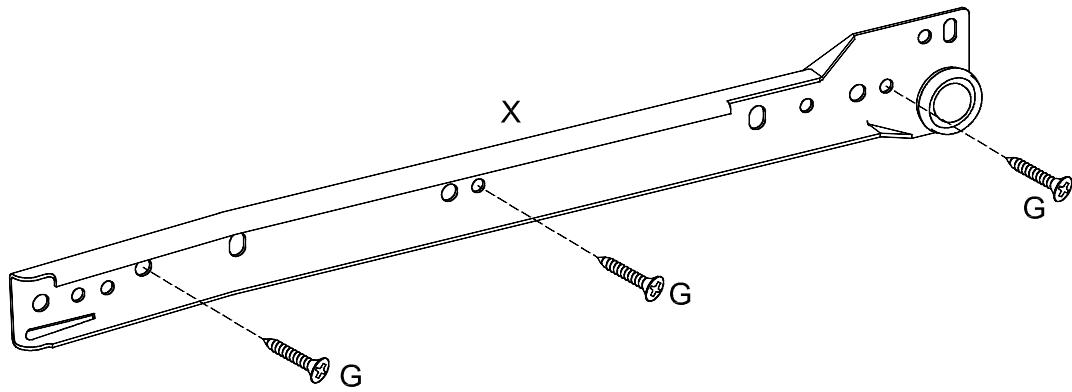

Step 6

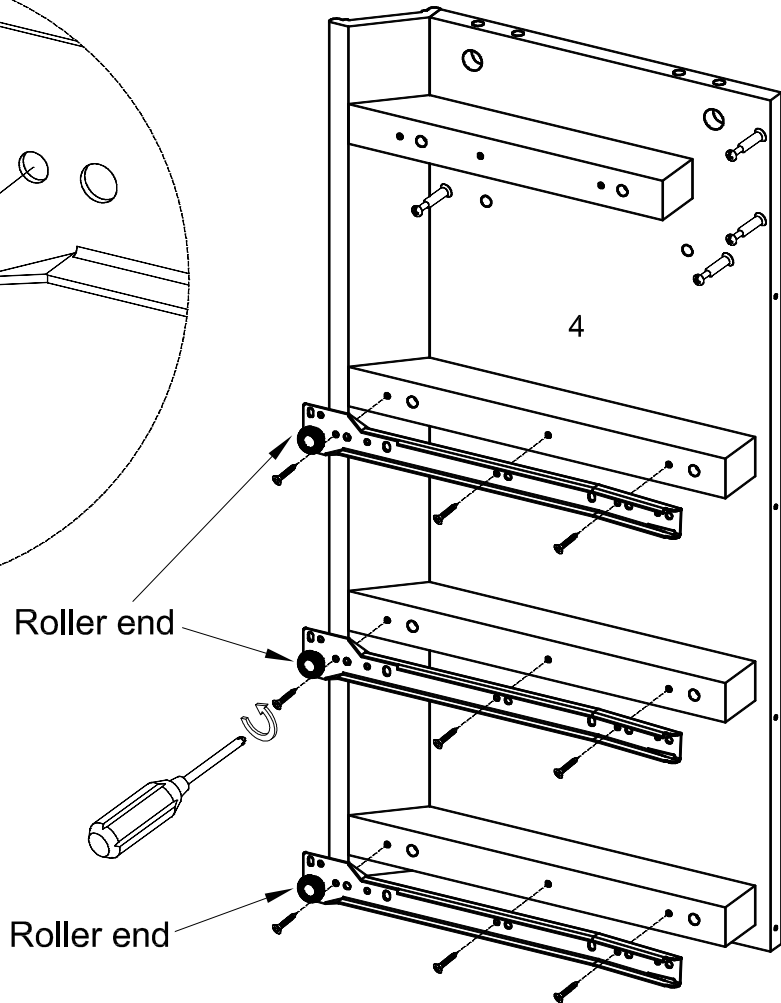
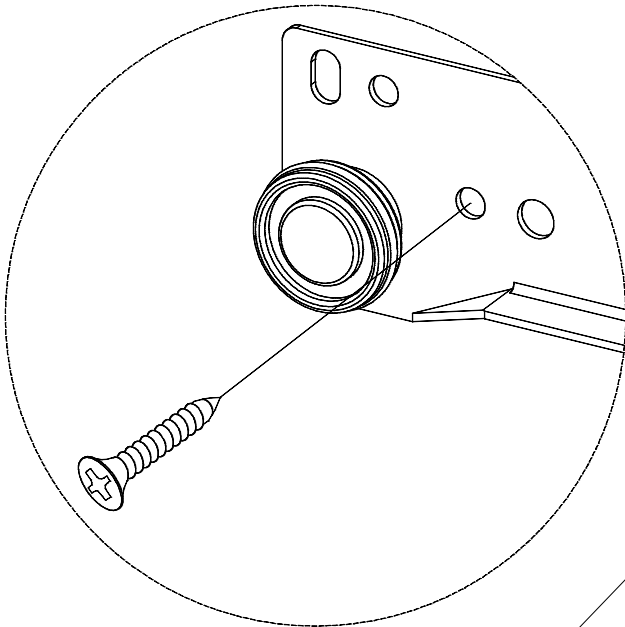
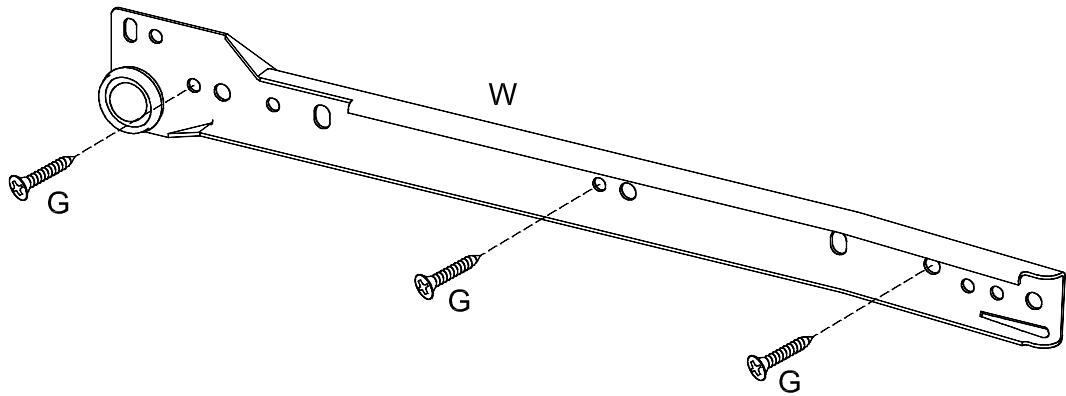

Step 7

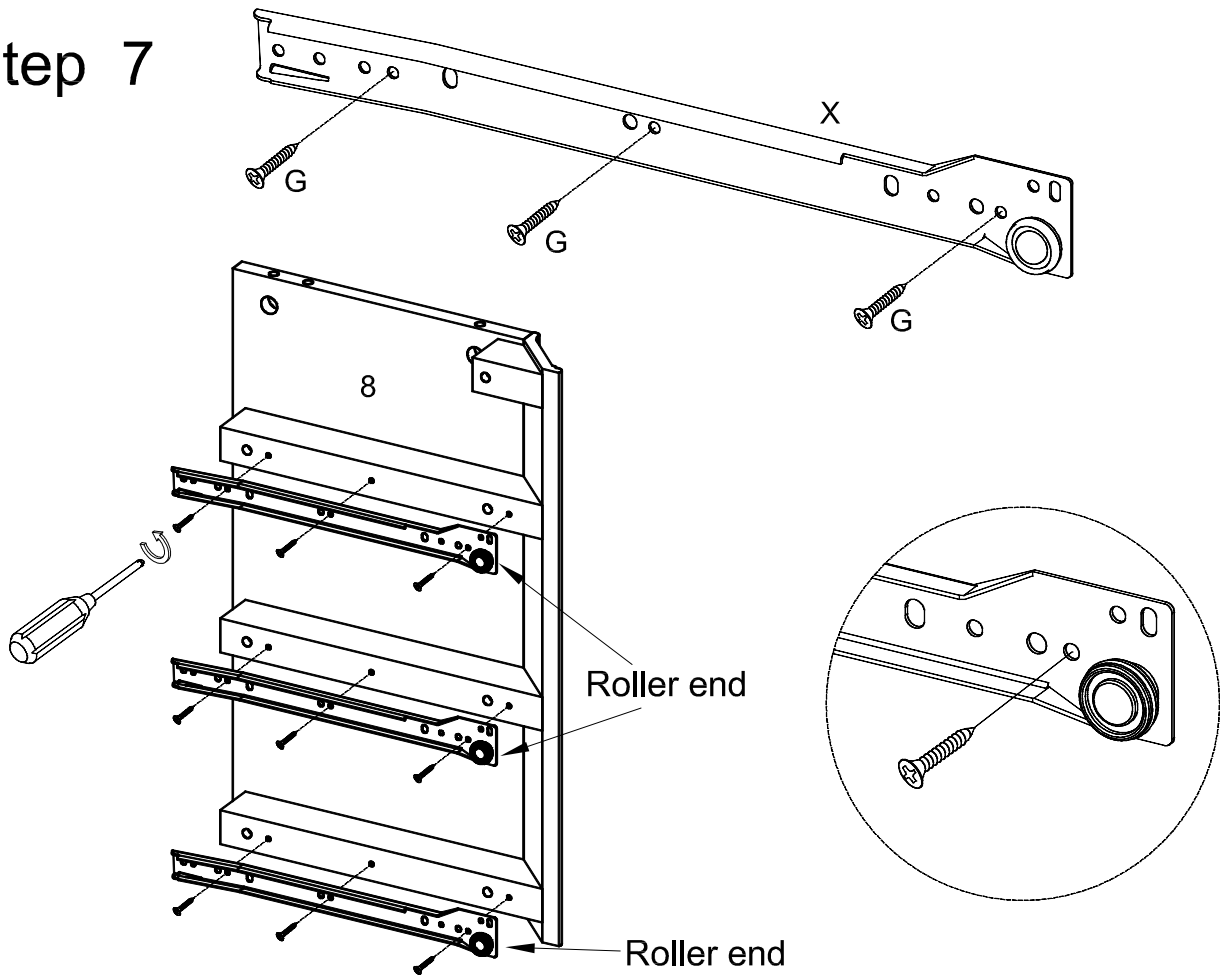

Step 8

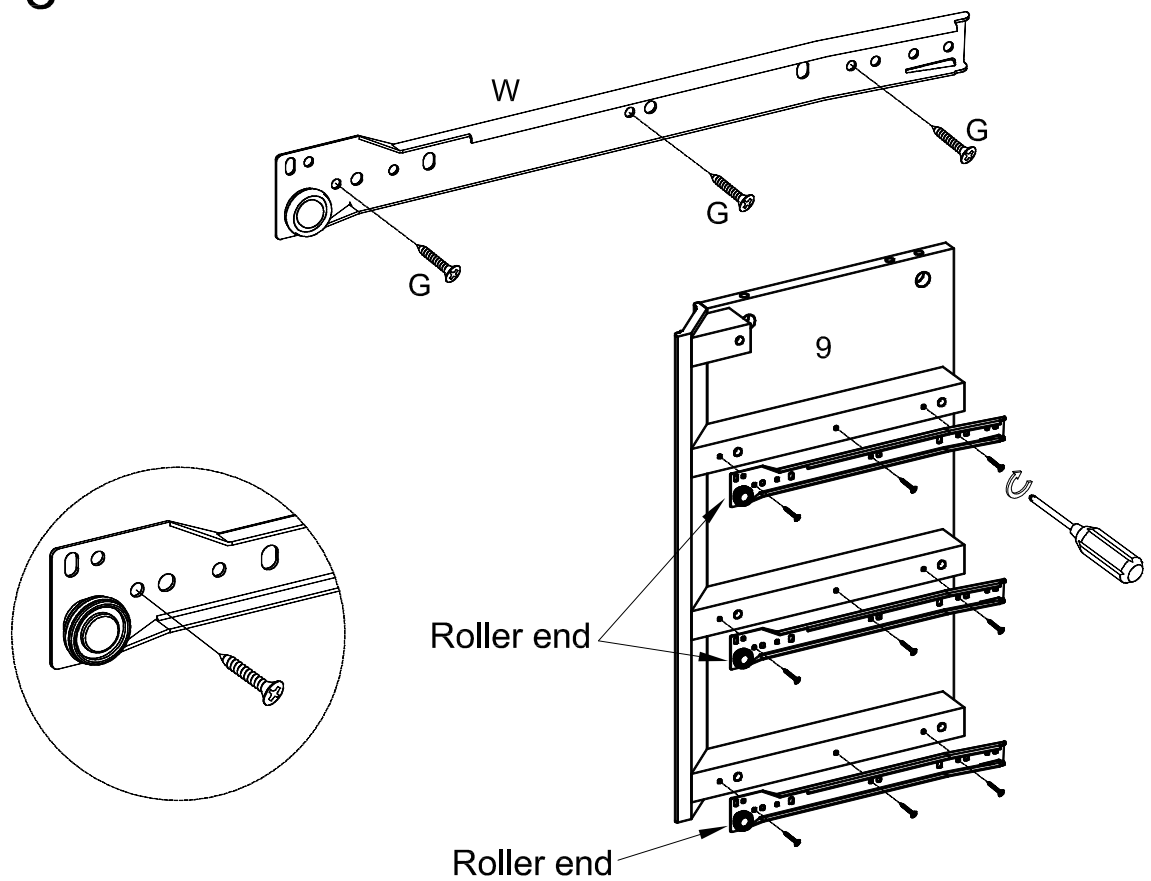

Step 9

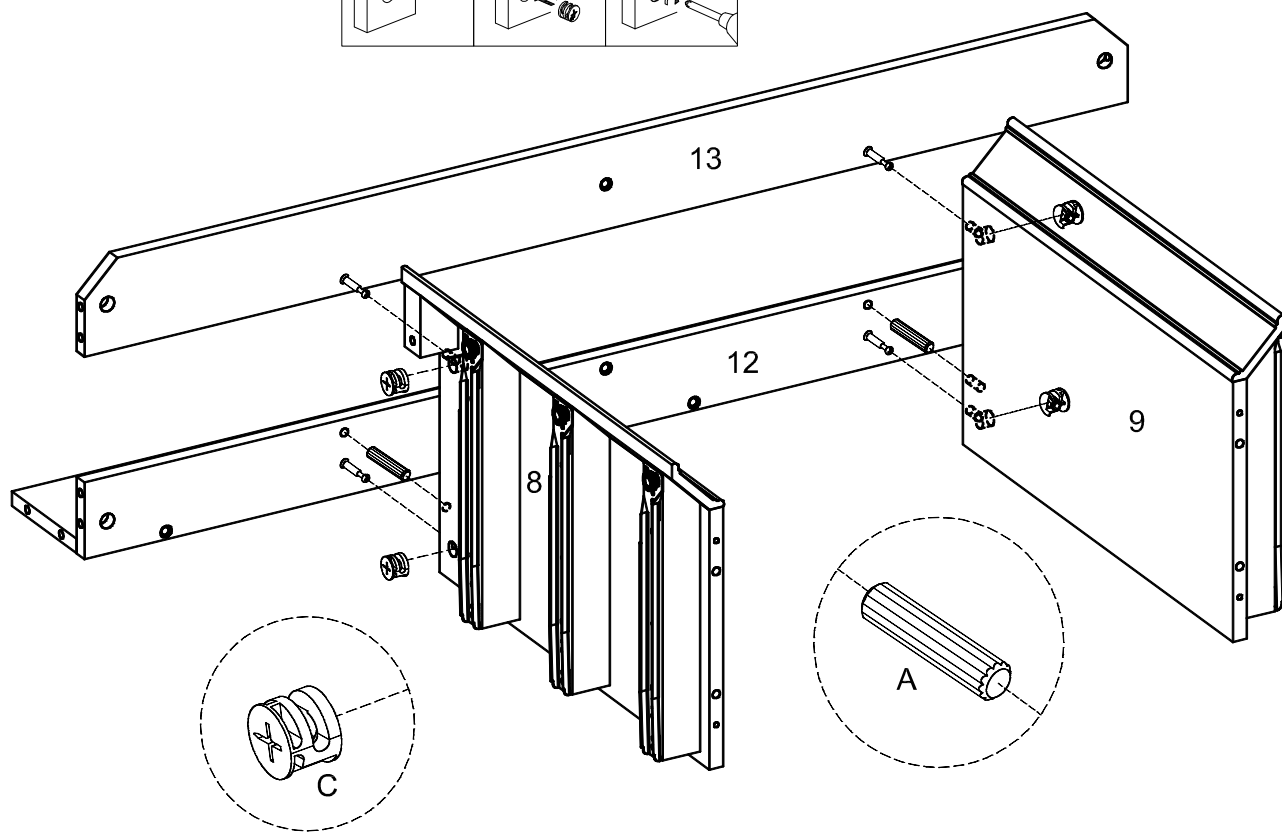
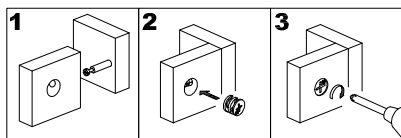

Step 10

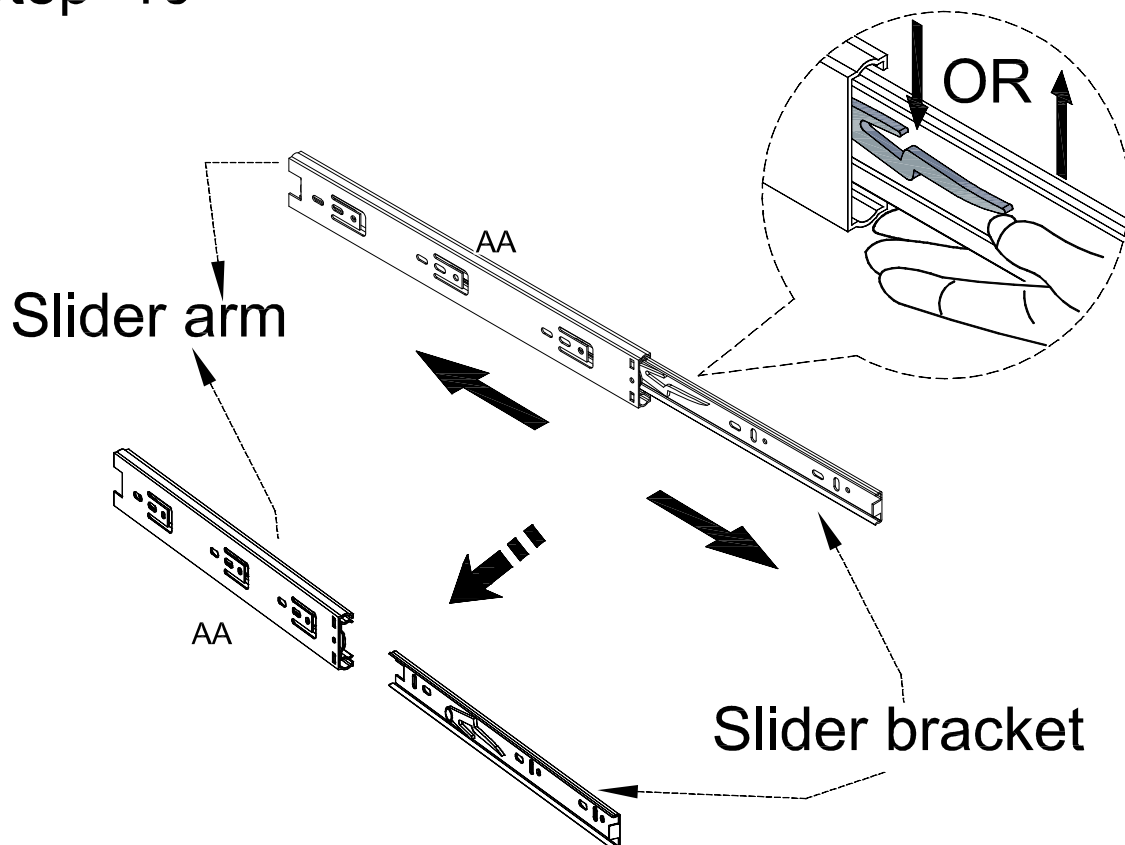

Step 11

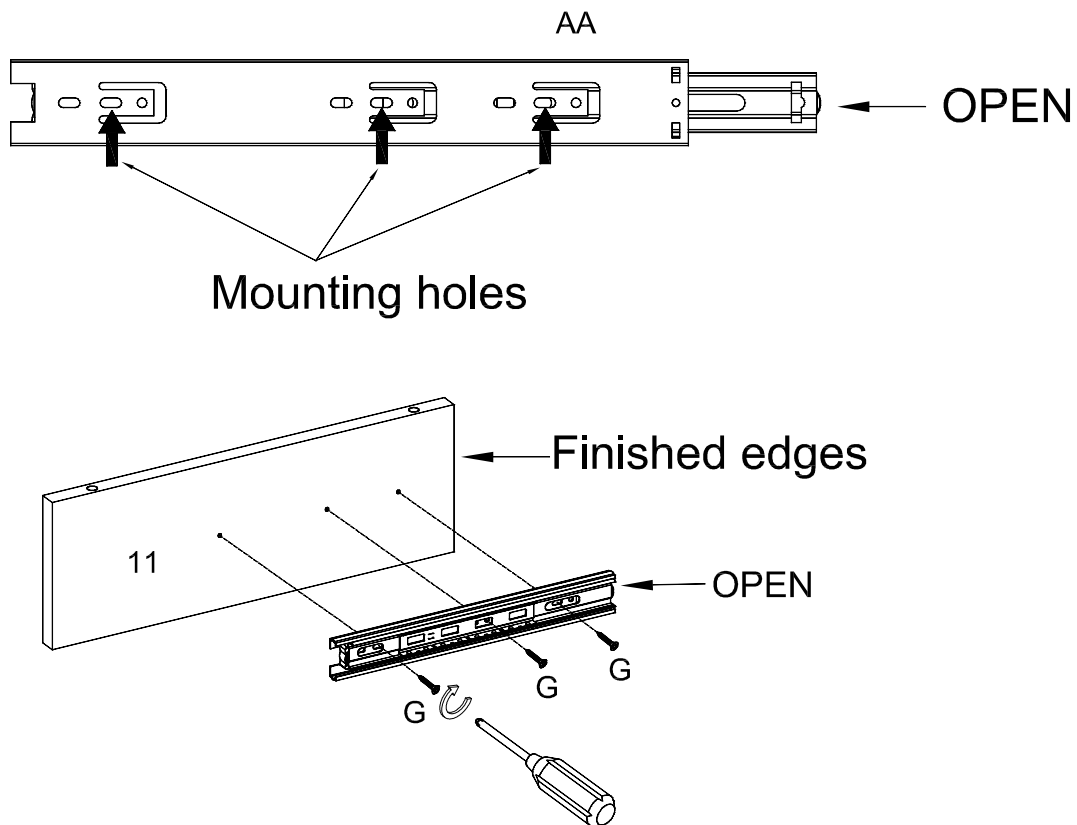

Step 12

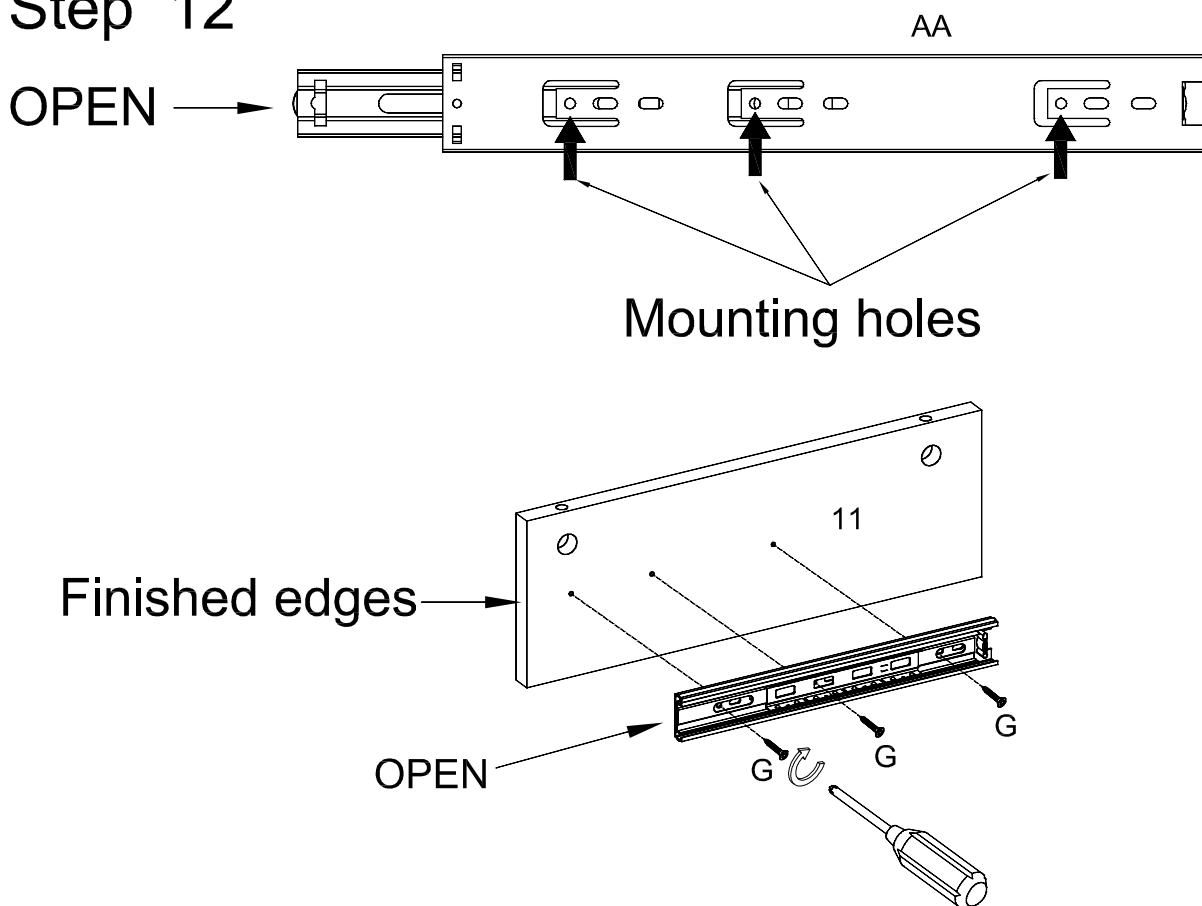

Step 13

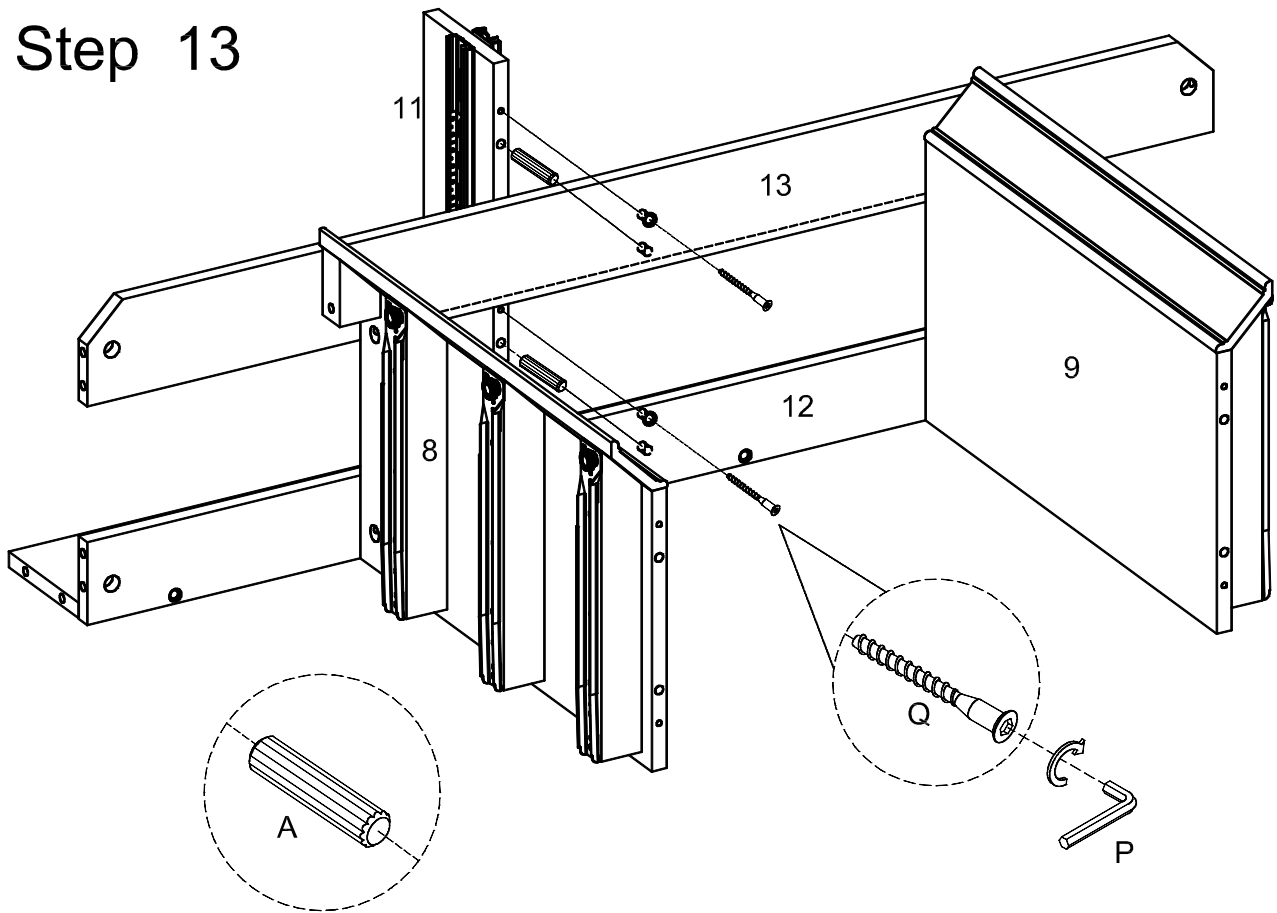

Step 14

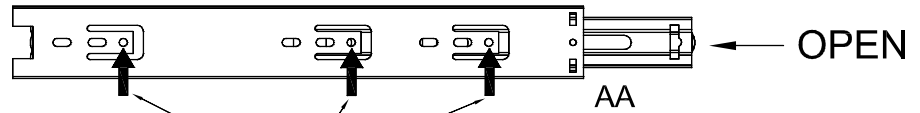

Mounting holes

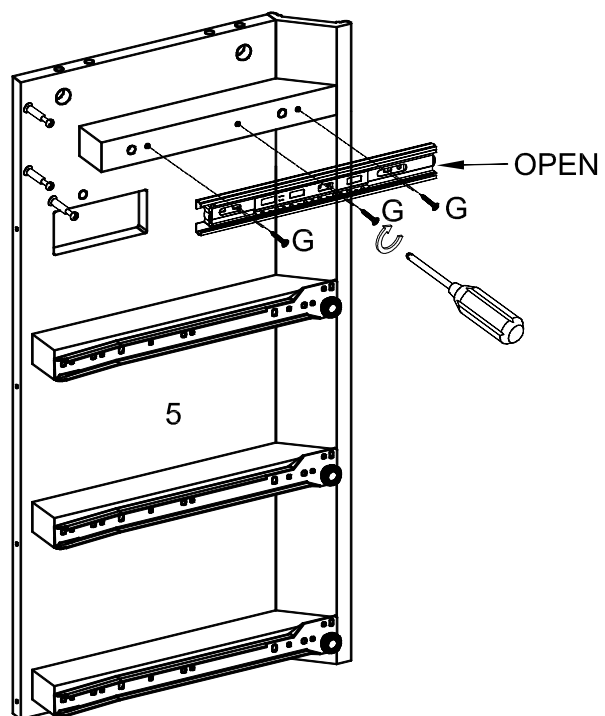

Step 15 OPEN

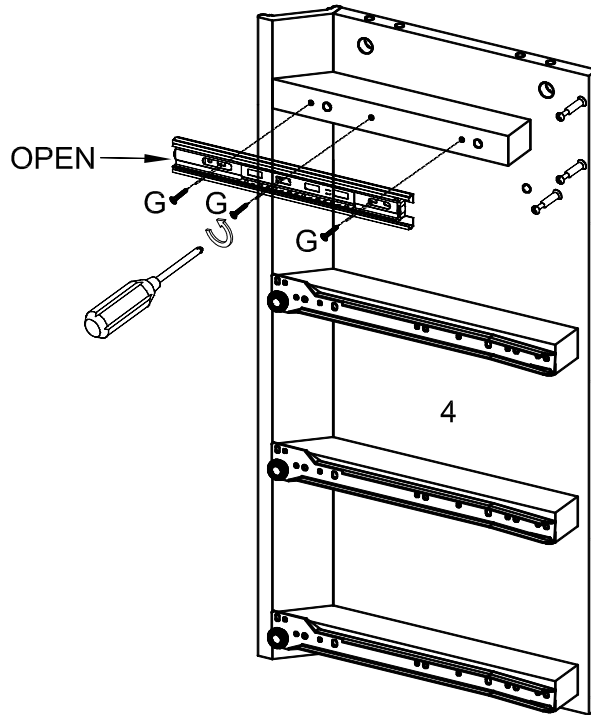
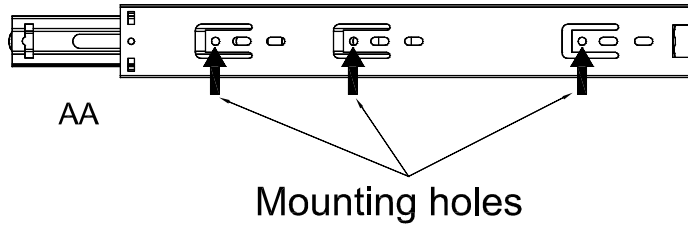

Step 16

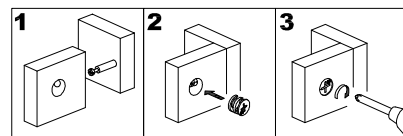
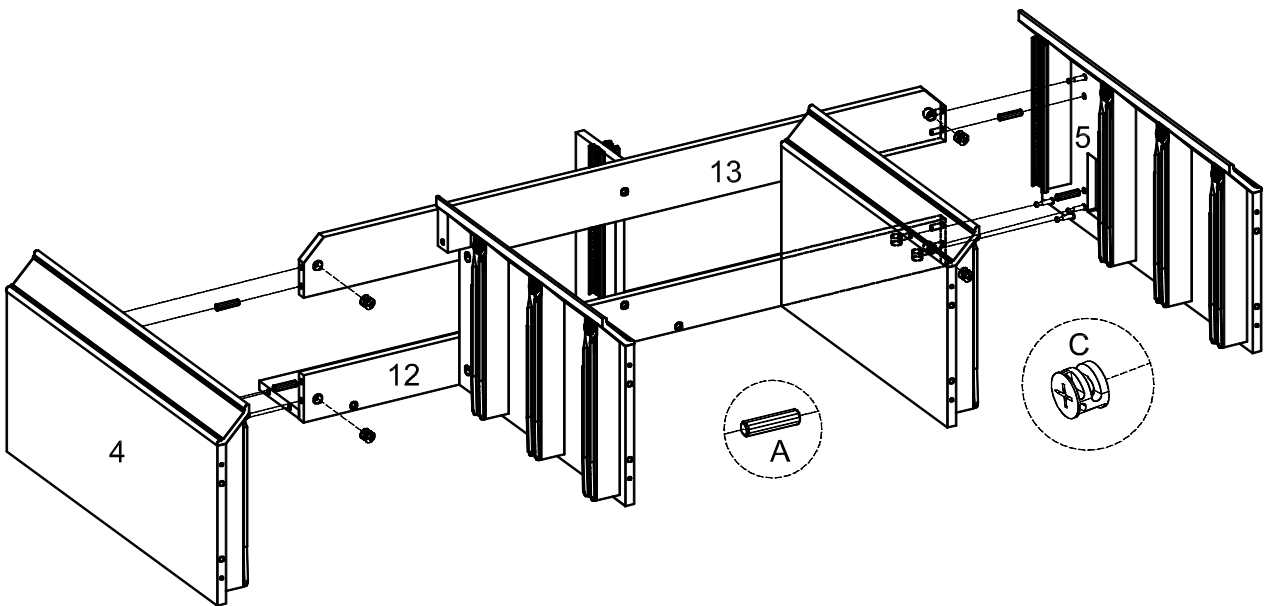

Step 17

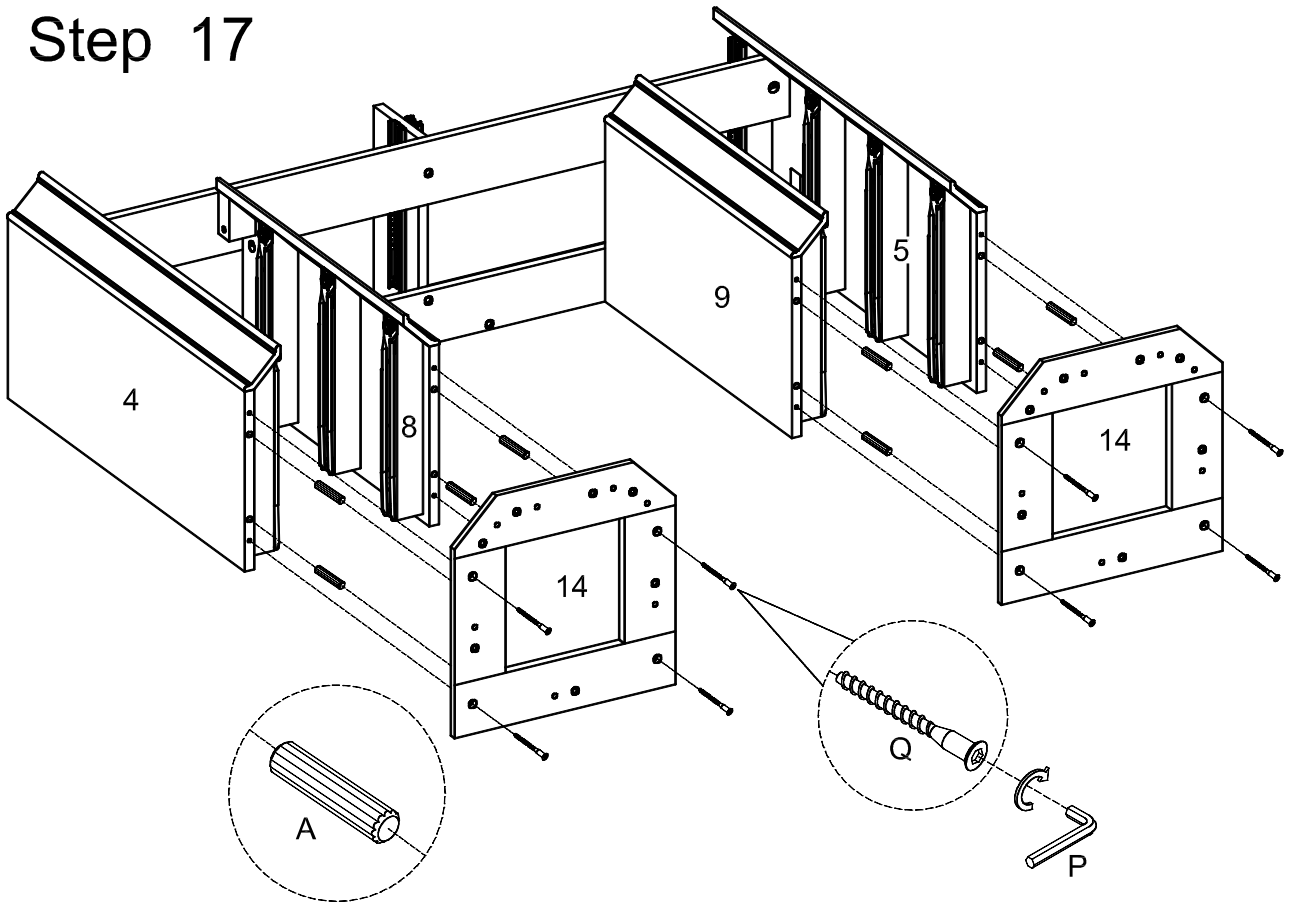

Step 18

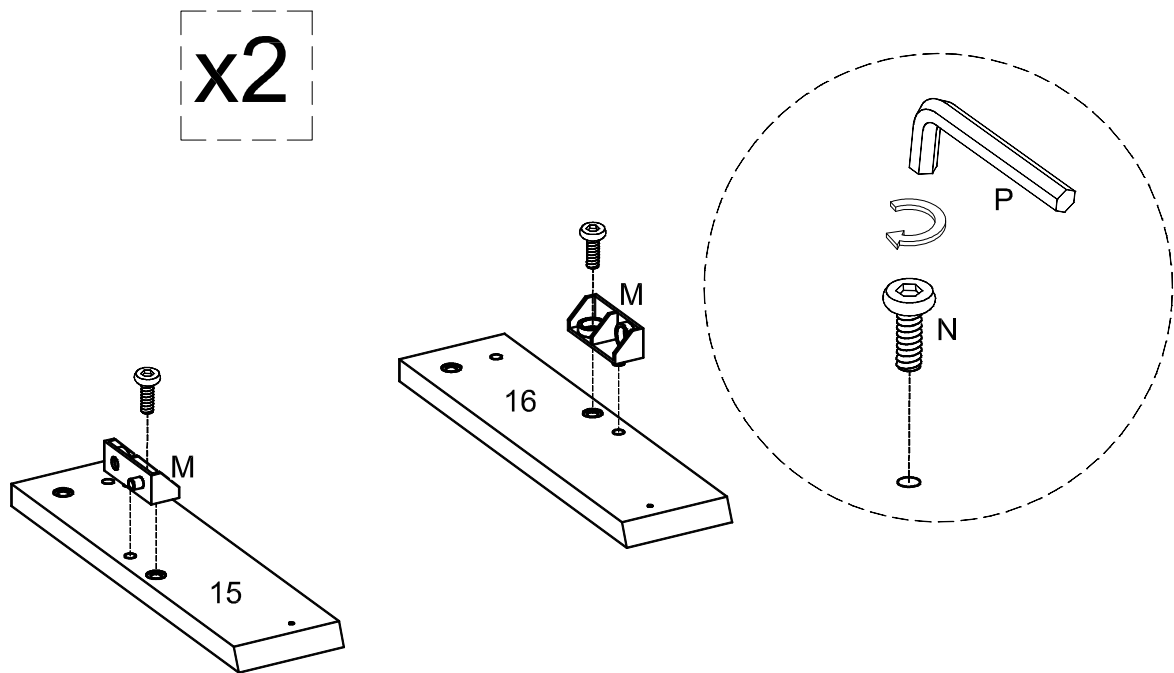

Step 19

x2

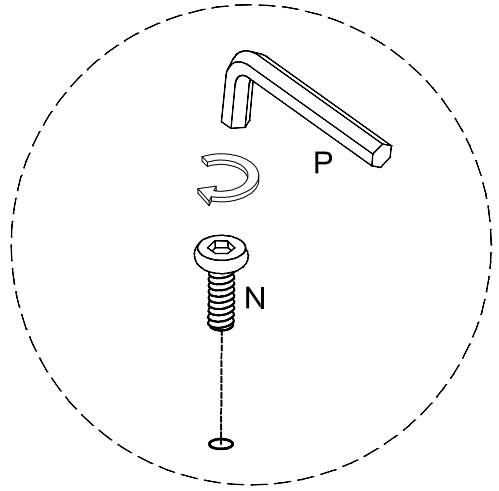
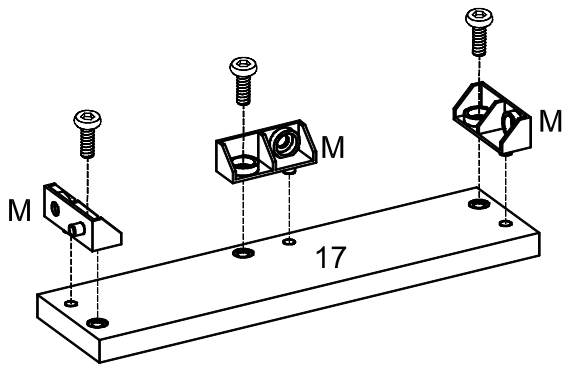

Step 20

x2

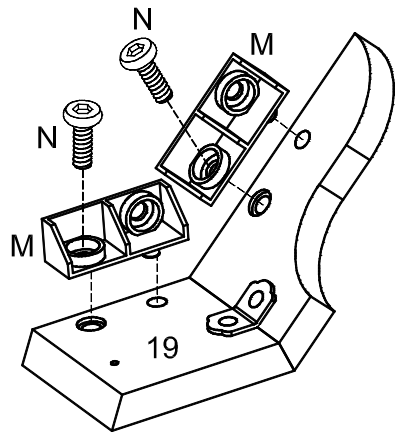
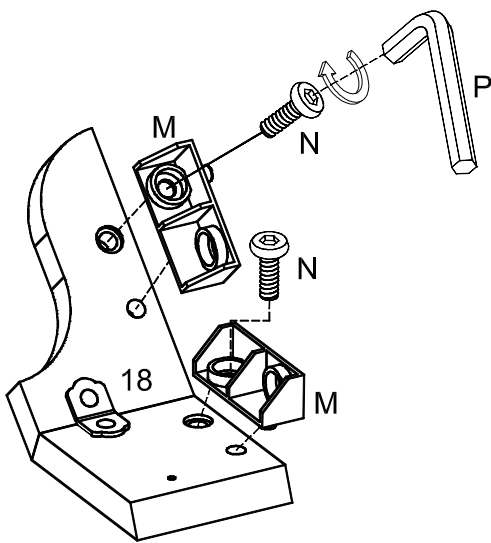

Step 21

x2

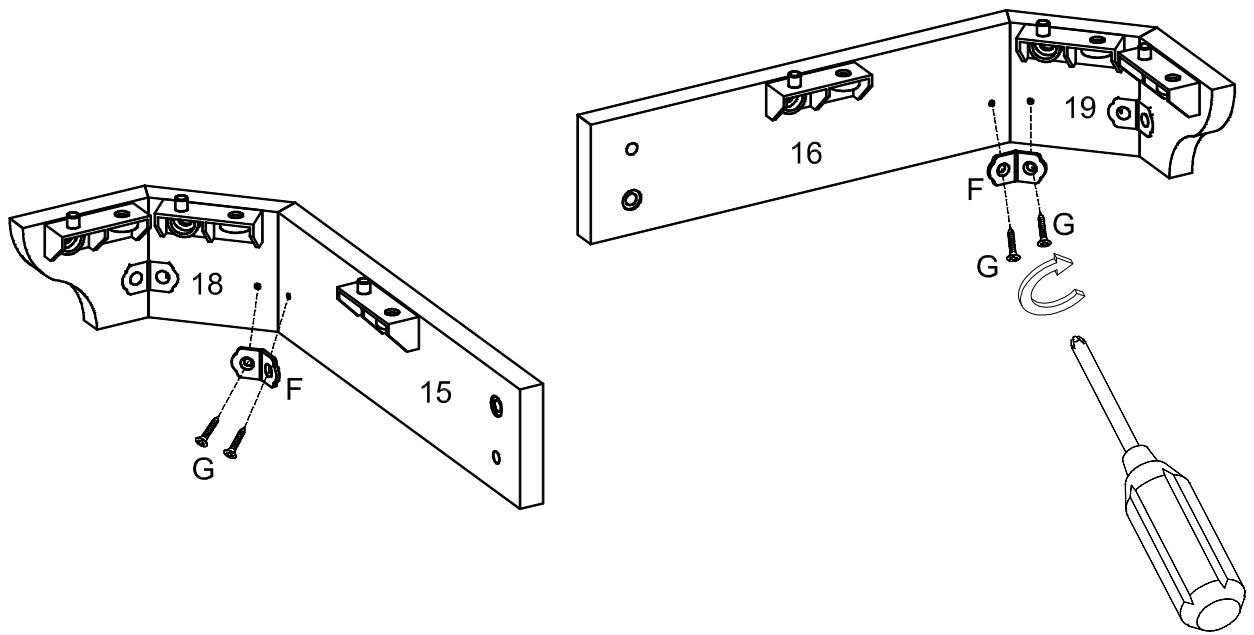

Step 22

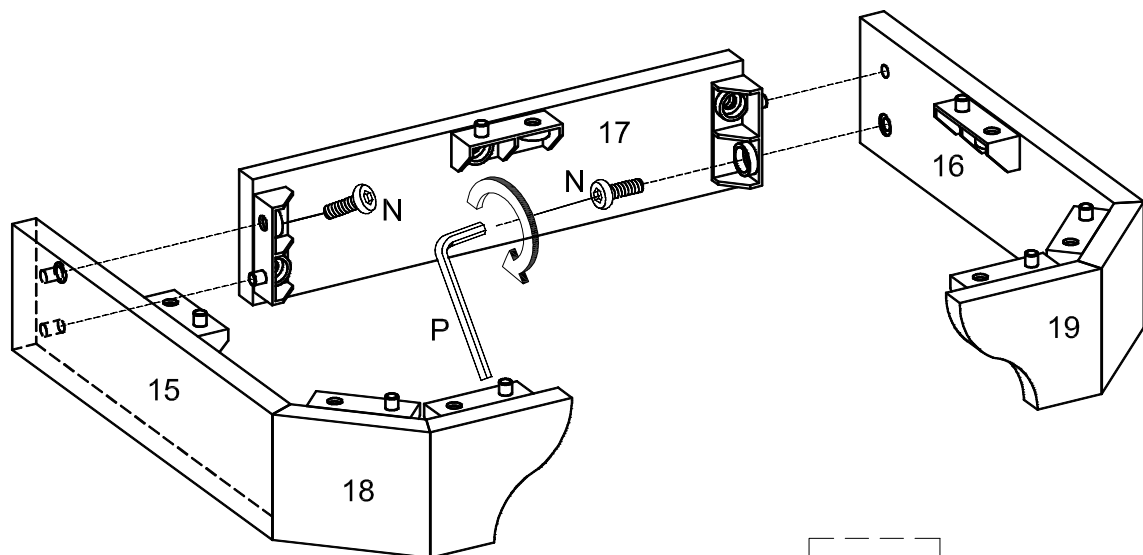

x2

Step 23

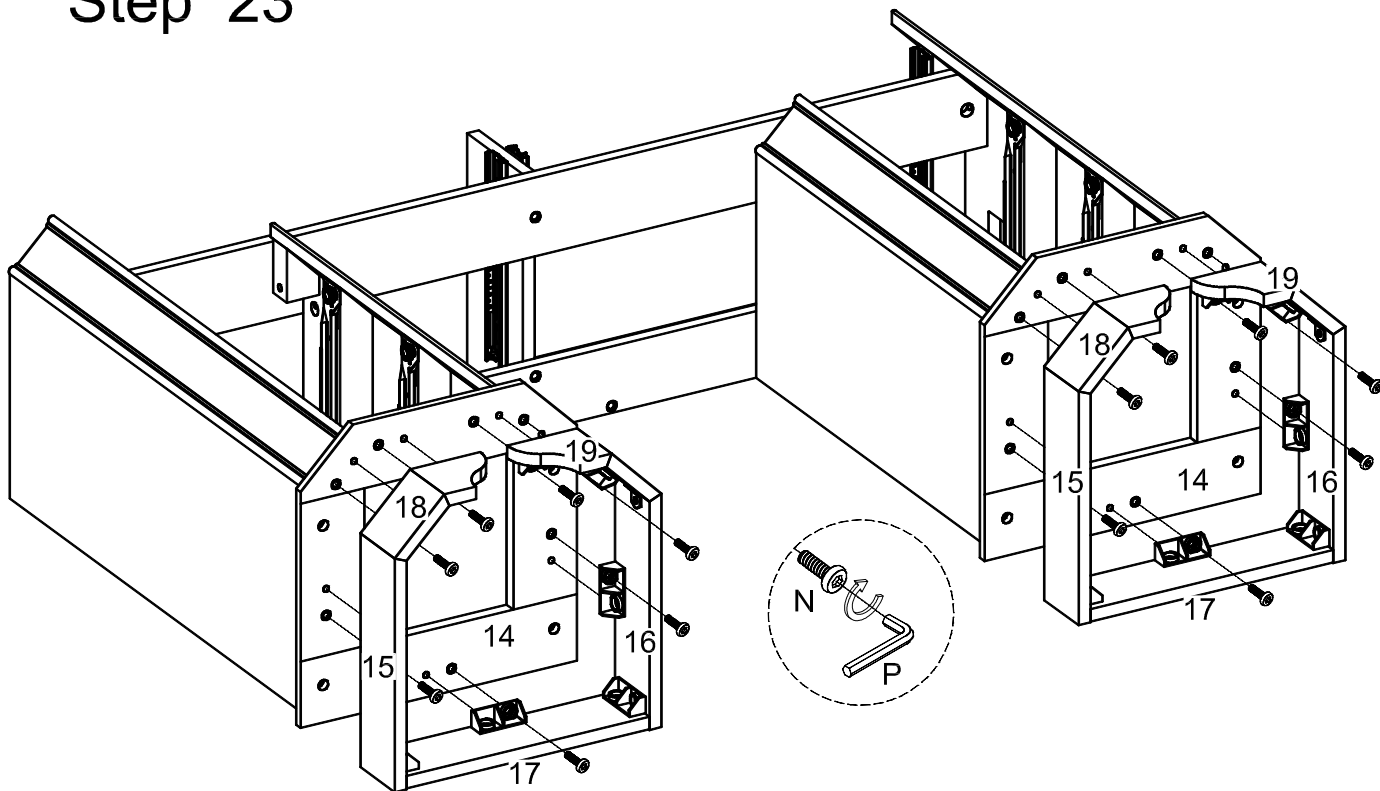

Step 24

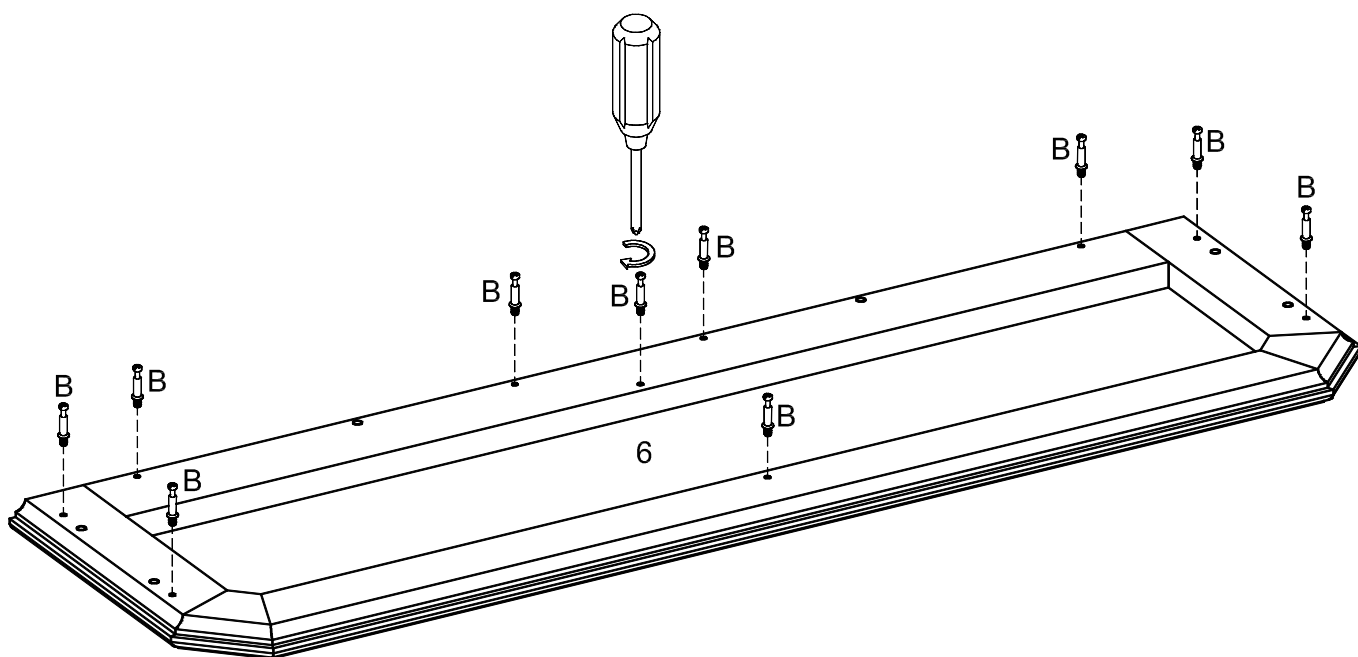

Step 25

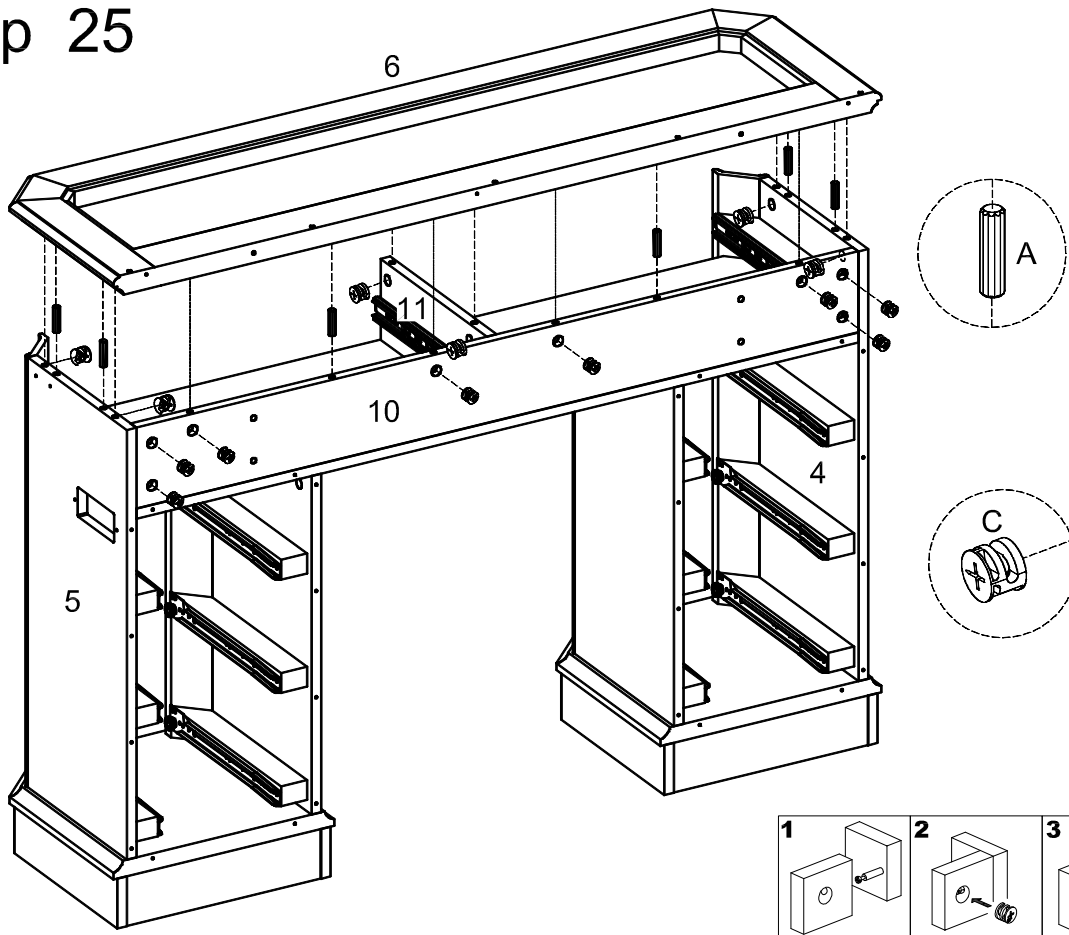

Step 26

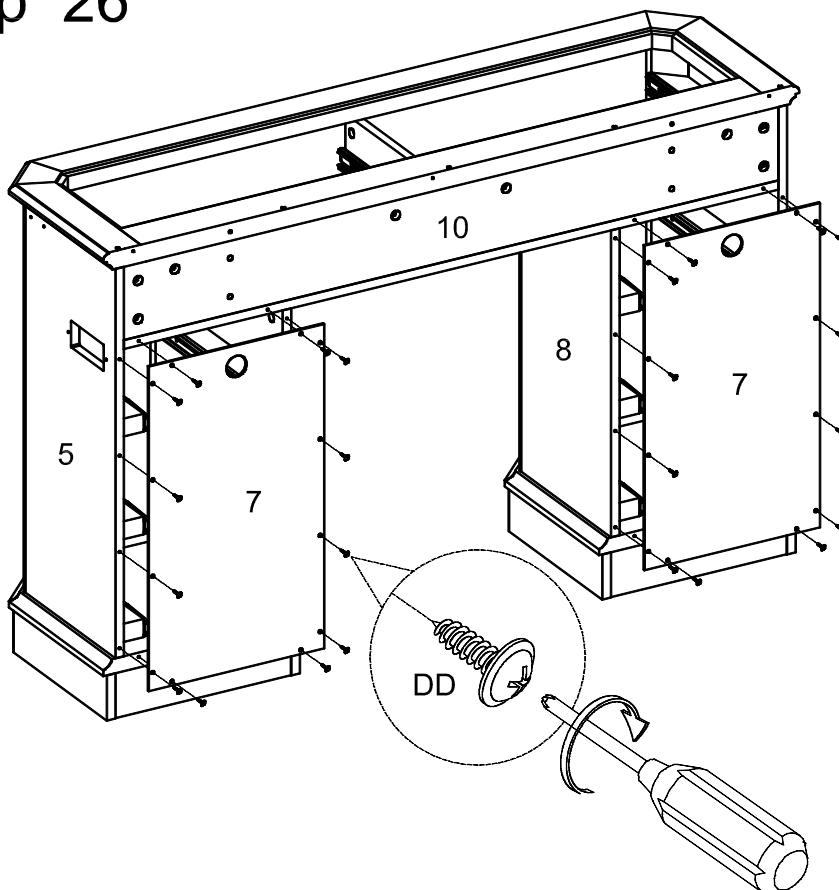

Step 27

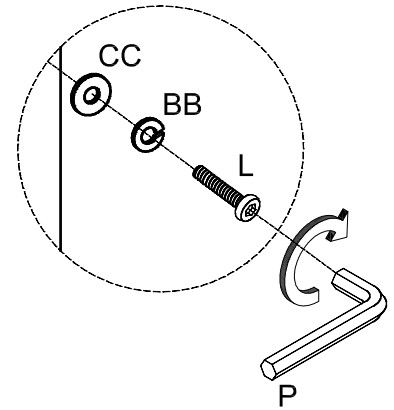
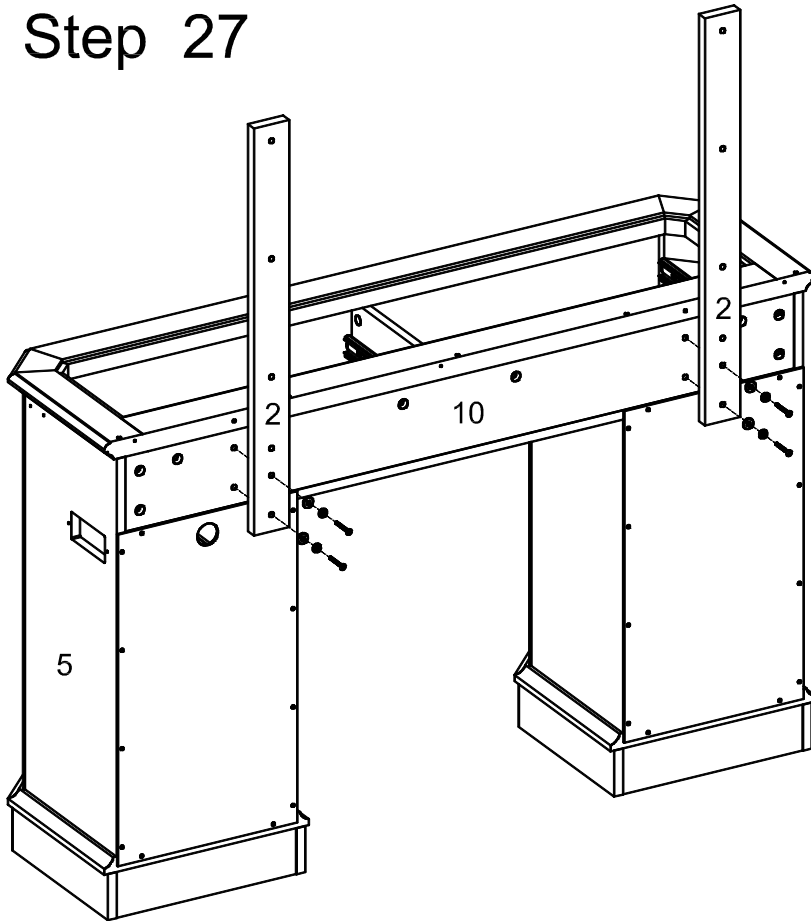

Step 28

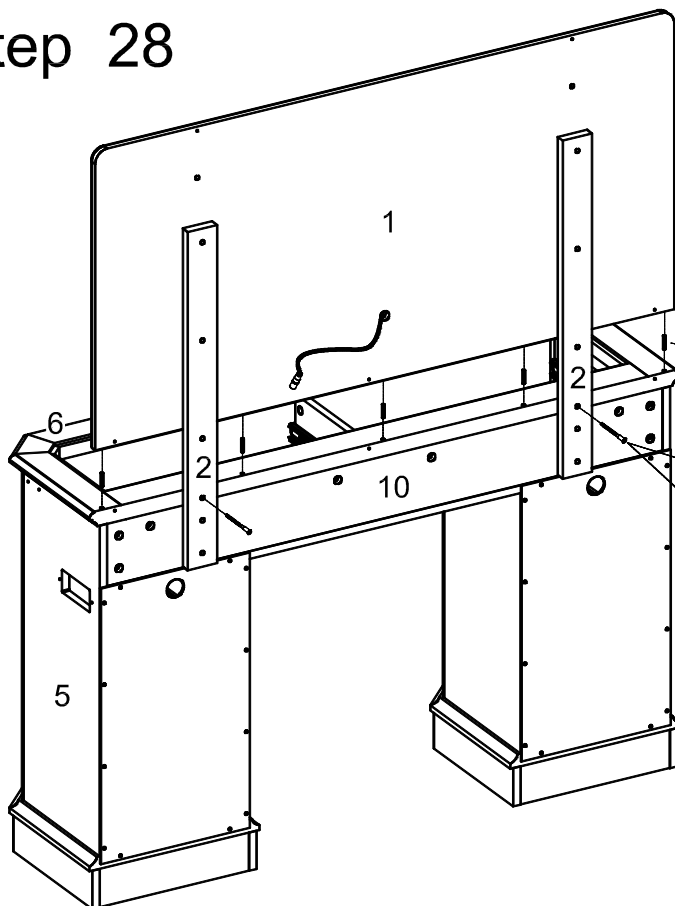

Small wooden dowel

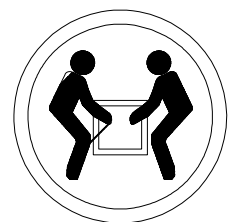
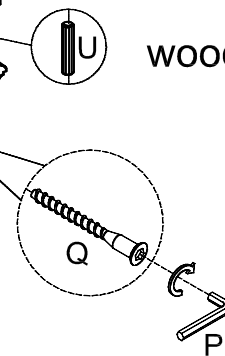

CAUTION: Heavy! You may need assistance with this step.

Step 29

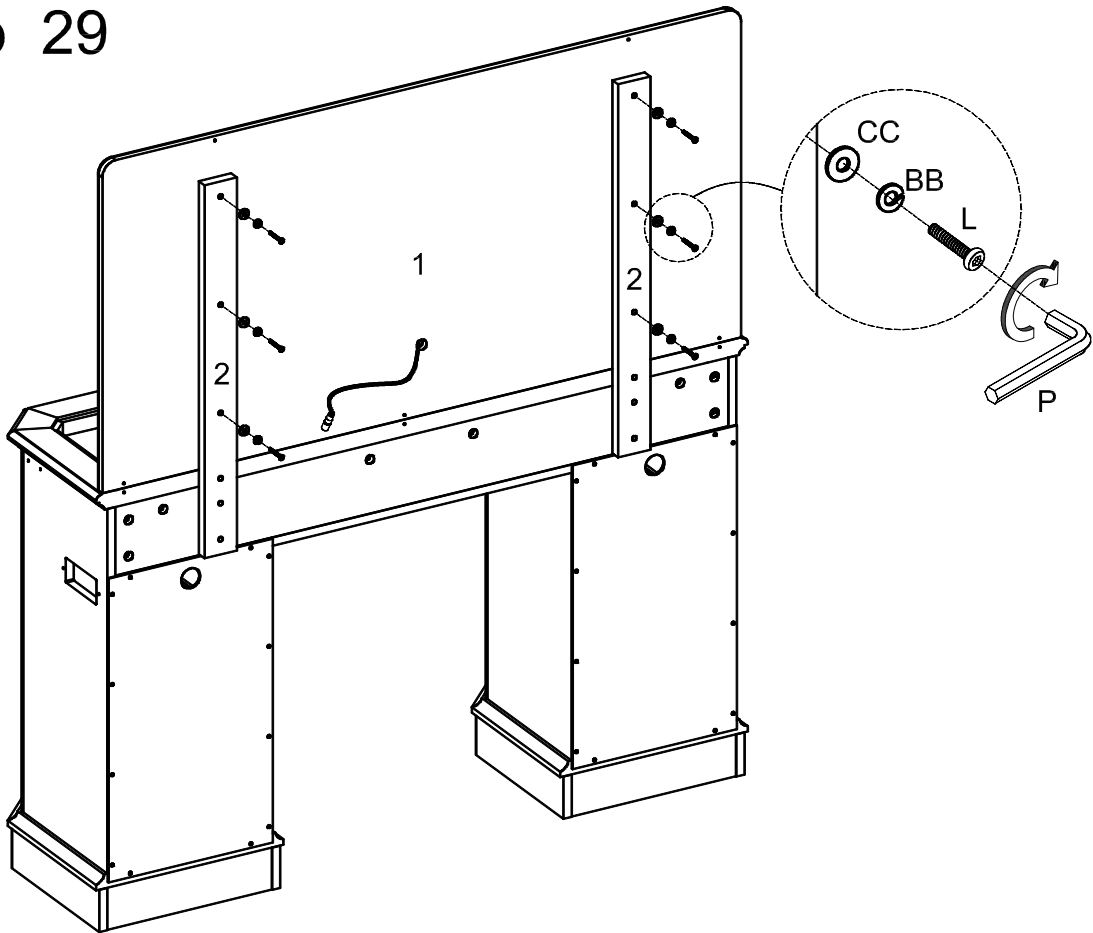

Step 30

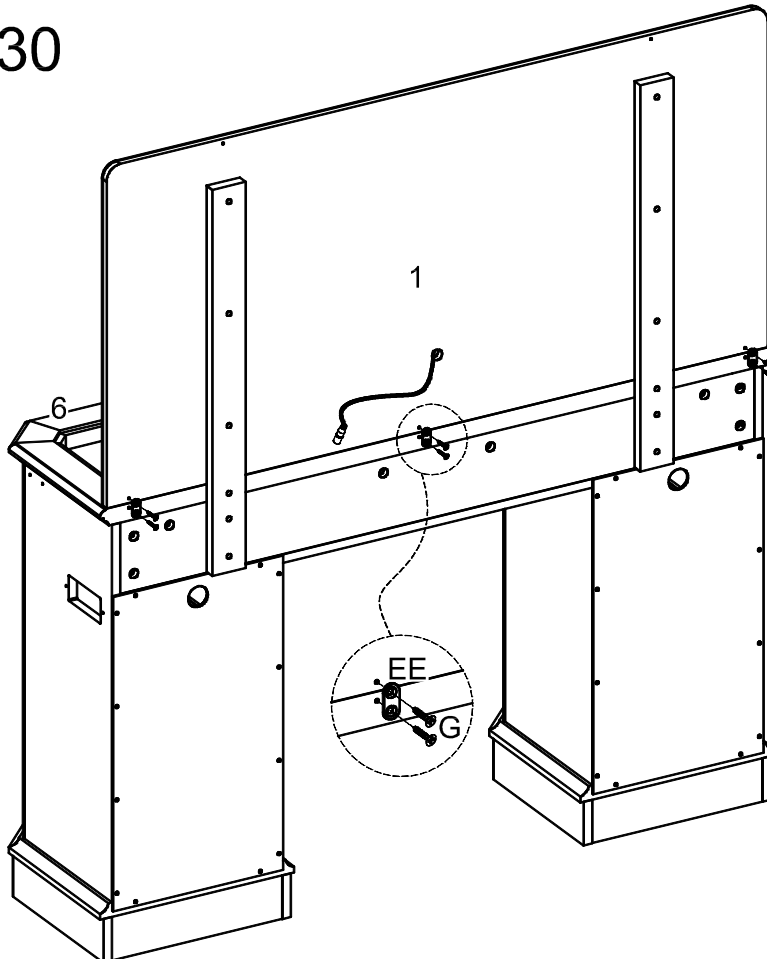

Step 31

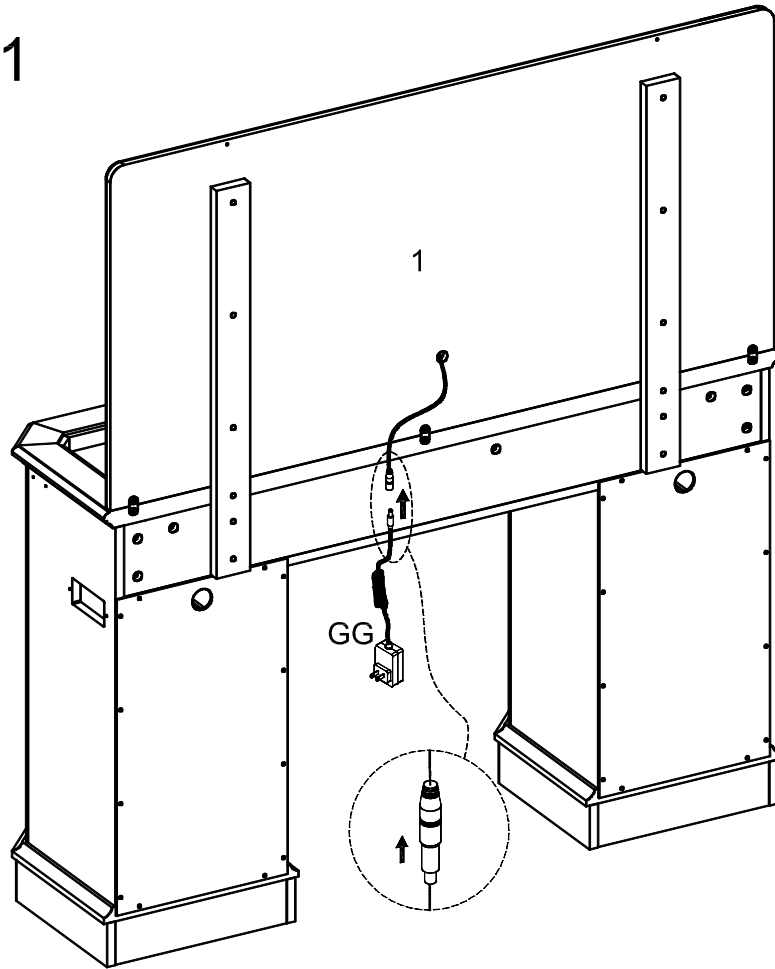

Step 32

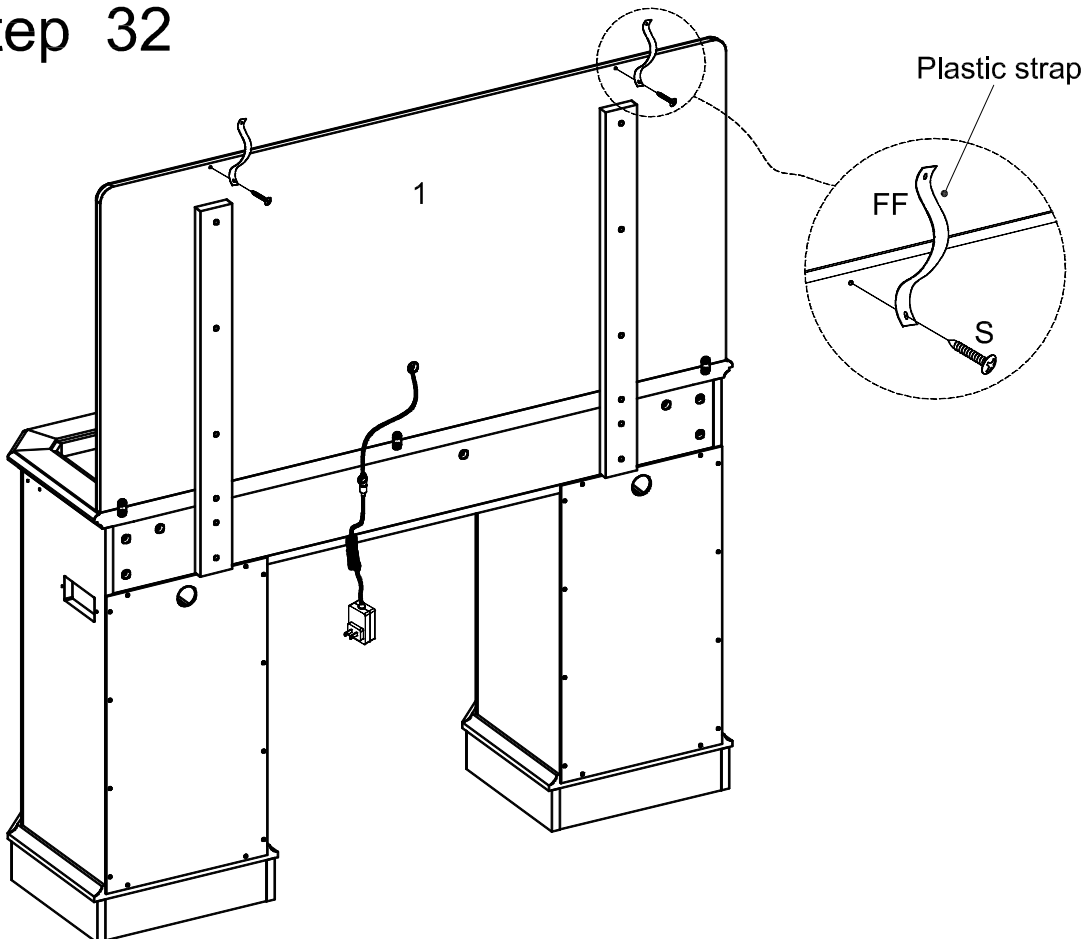

Step 33

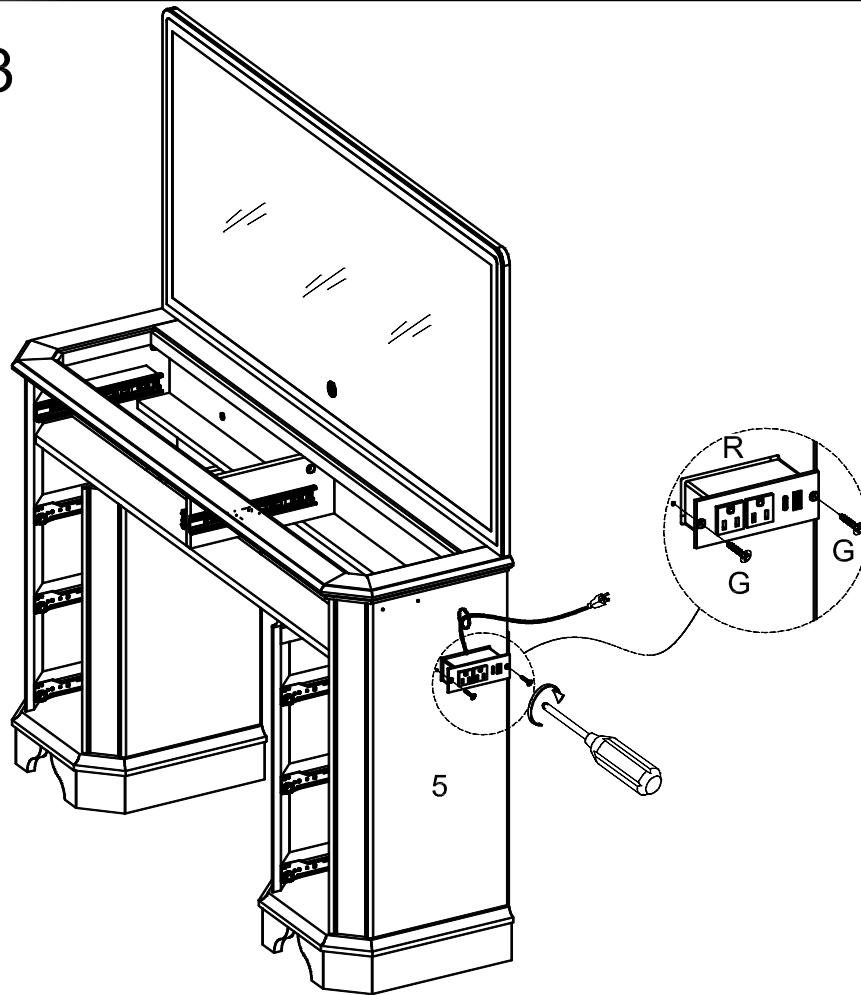

Step 34

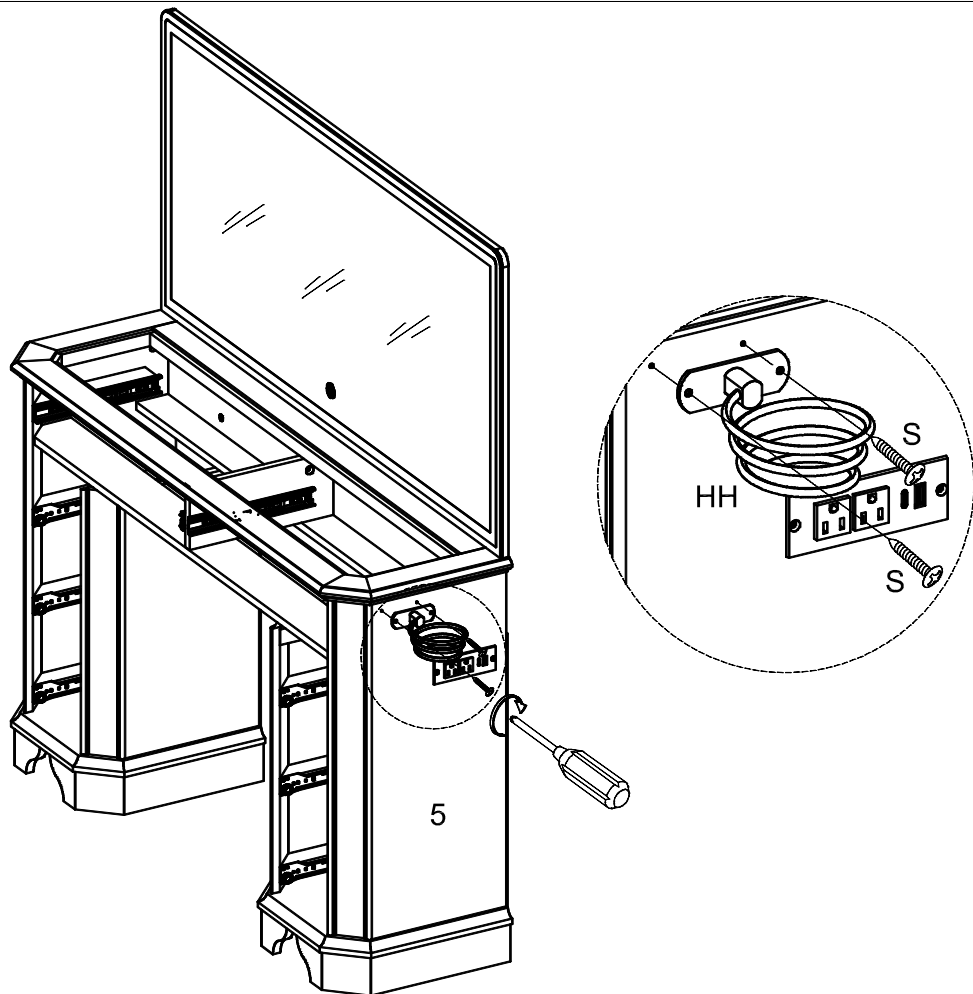

Step 35

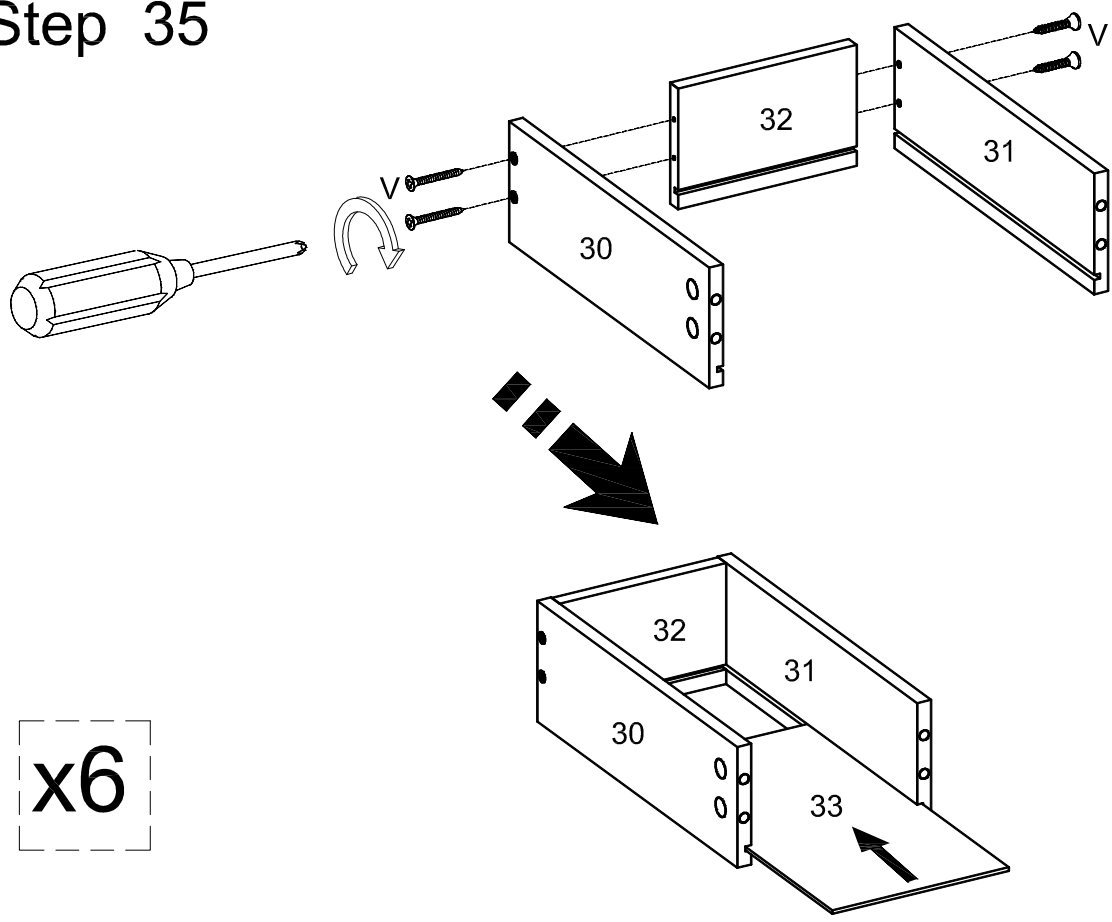

Step 36

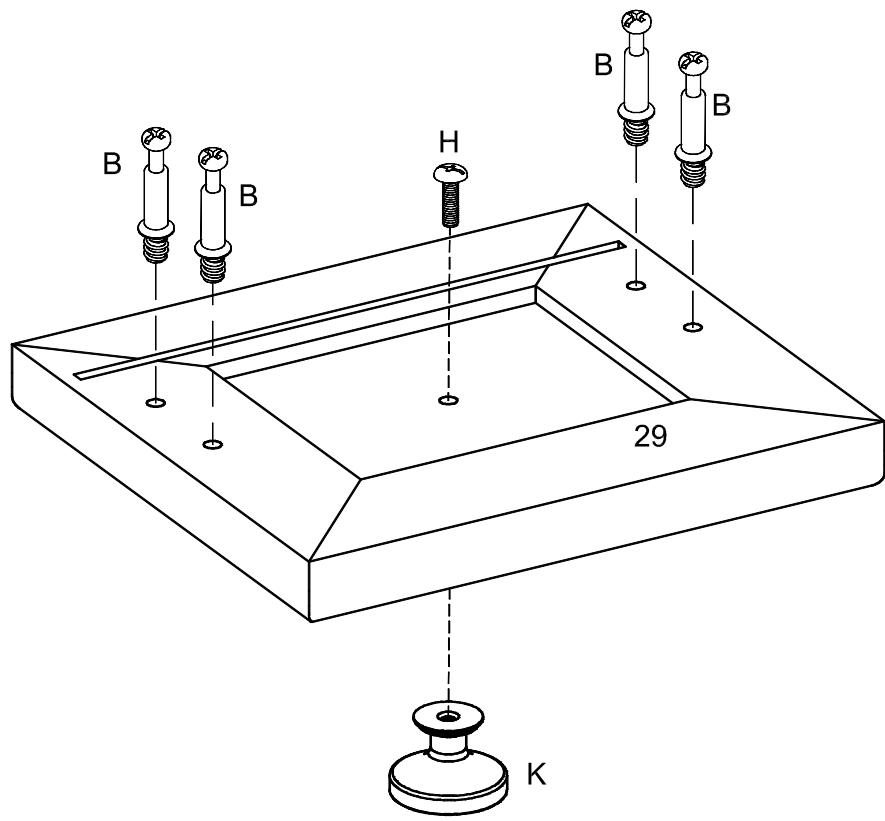

Step 37

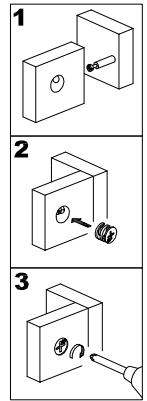
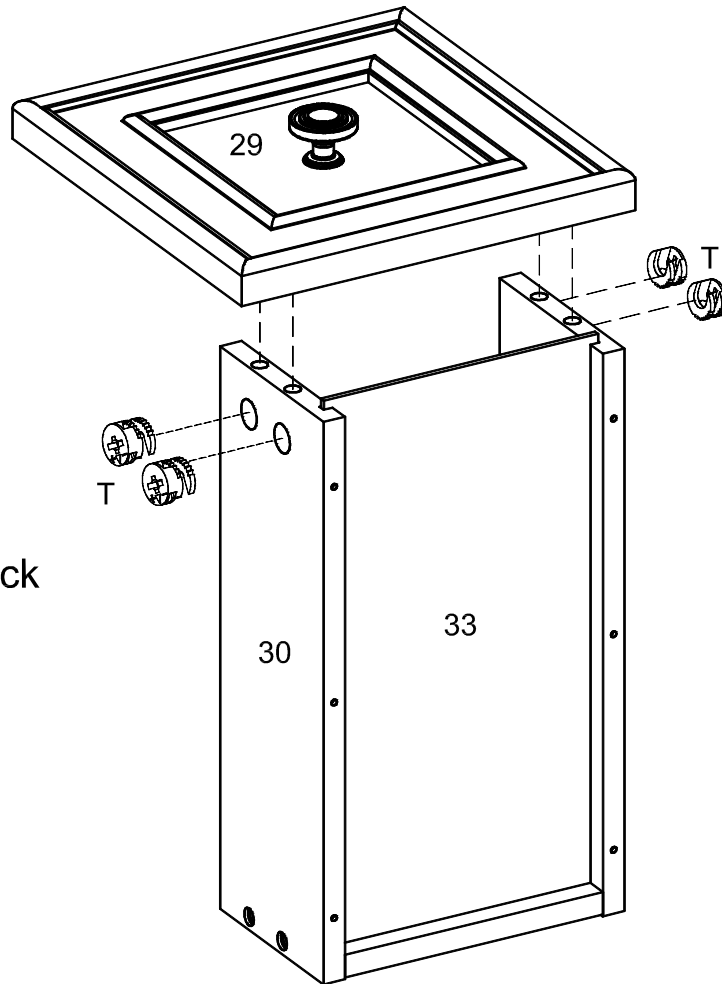

Small cam lock

x6

Step 38

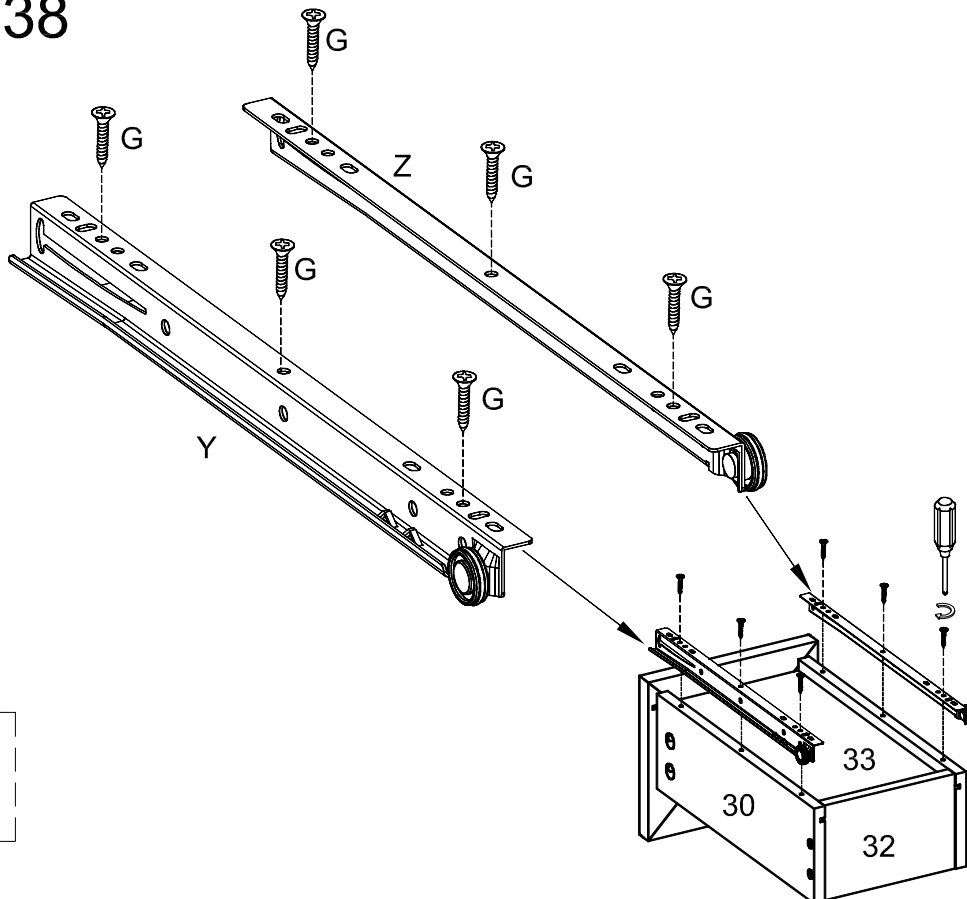

x6

Step 39

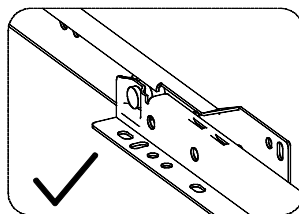
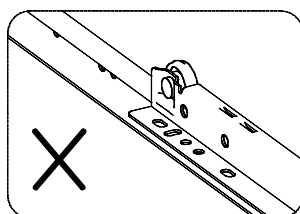
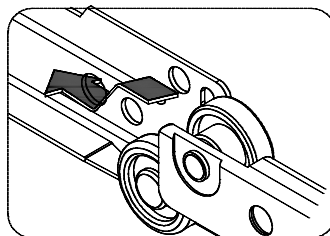
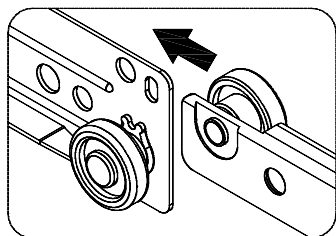
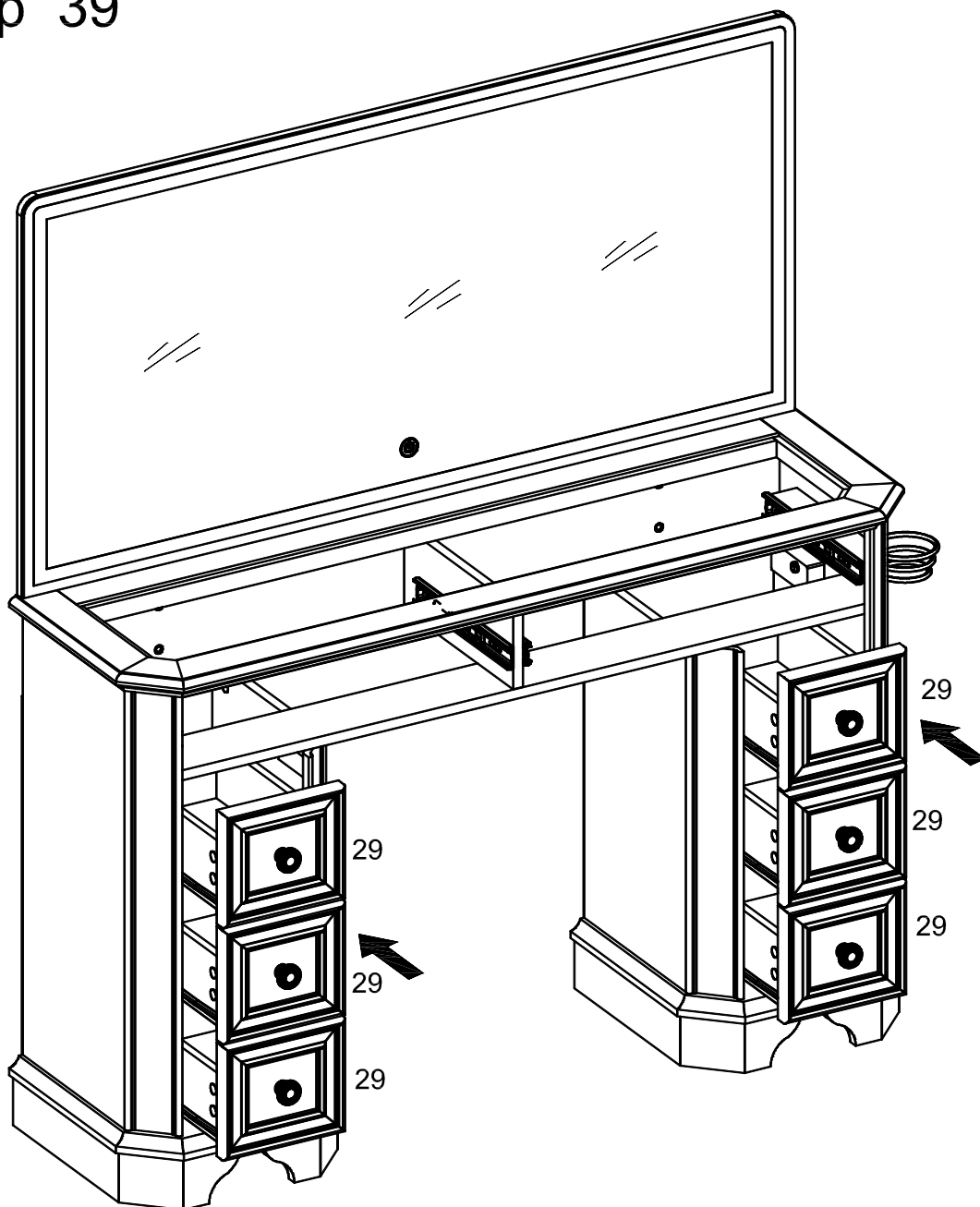

Step 40

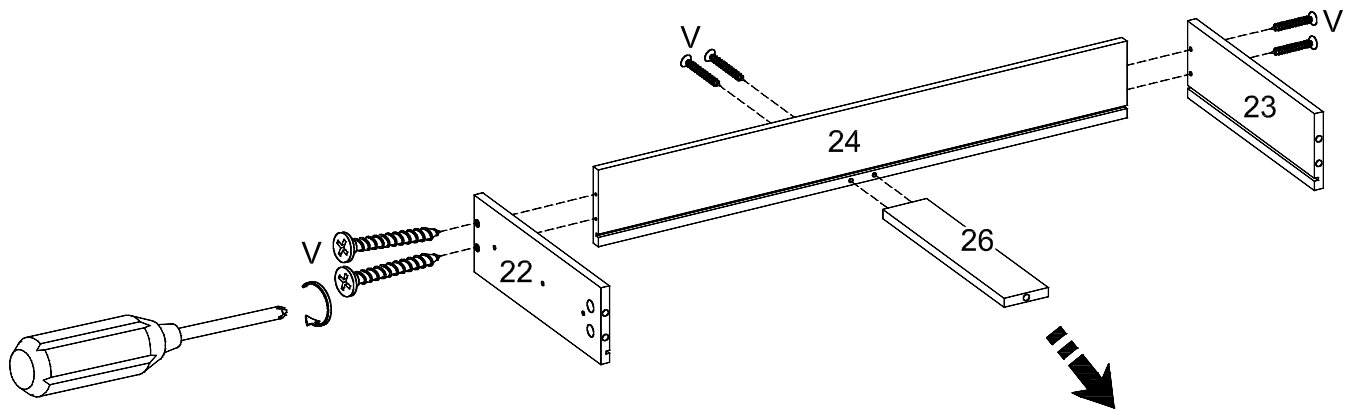

x2

Step 41

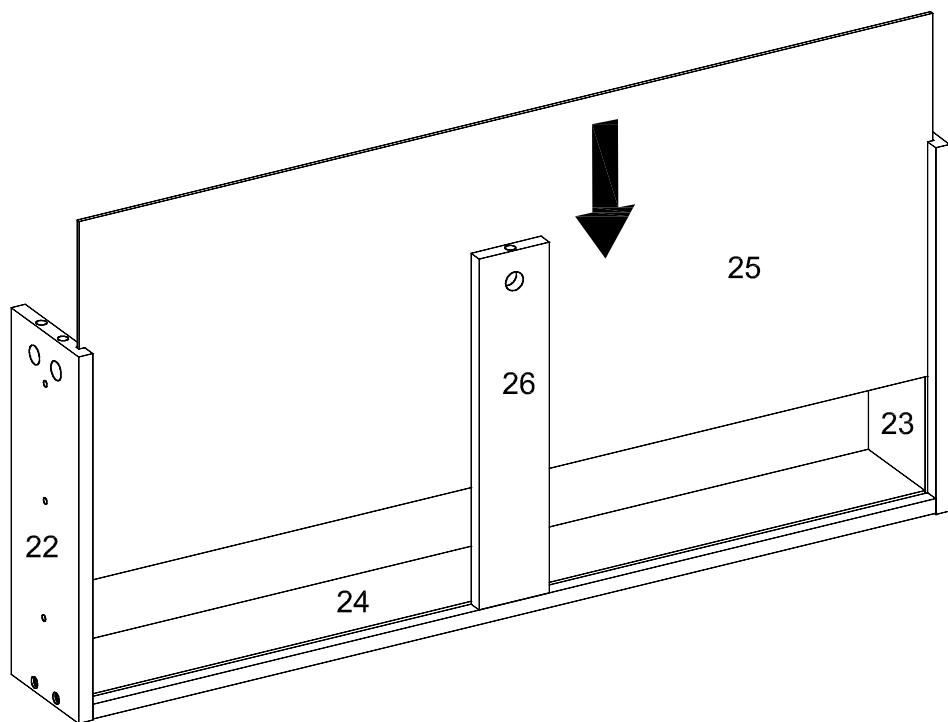

x2

Step 42

Care the direction of handle (J)

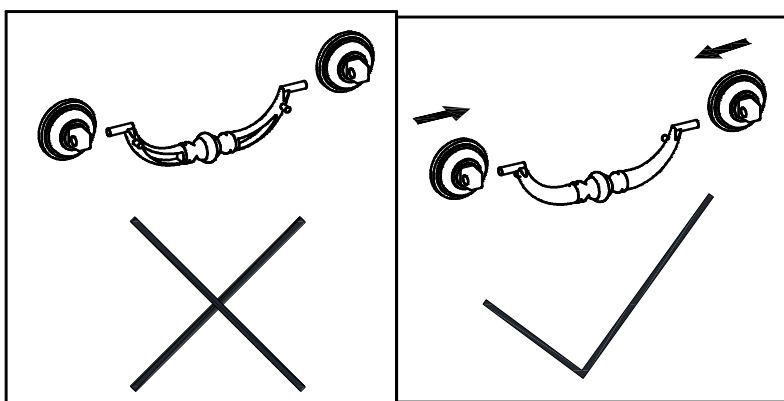
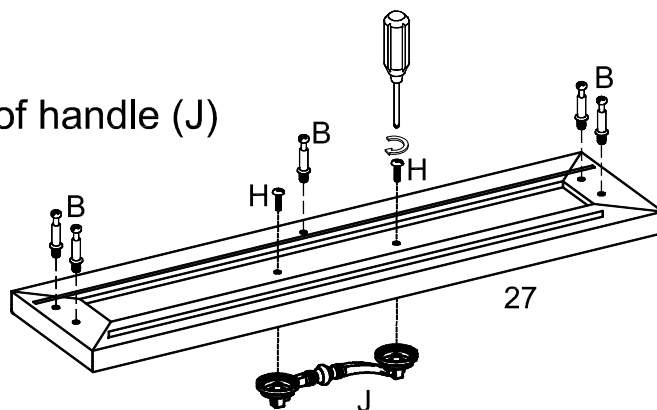

Step 43

Care the direction of handle (J)

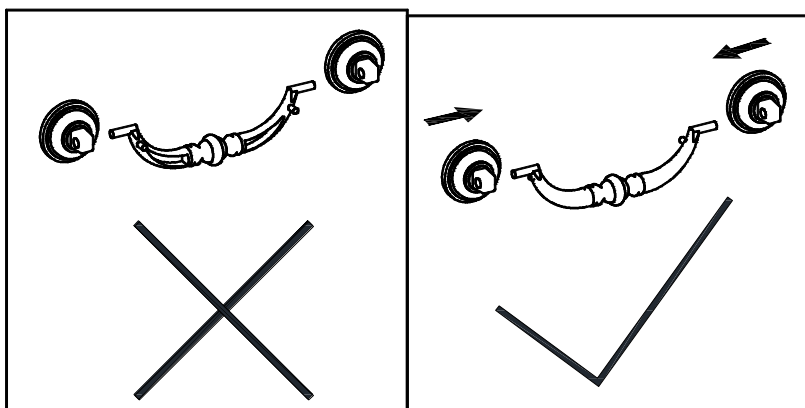
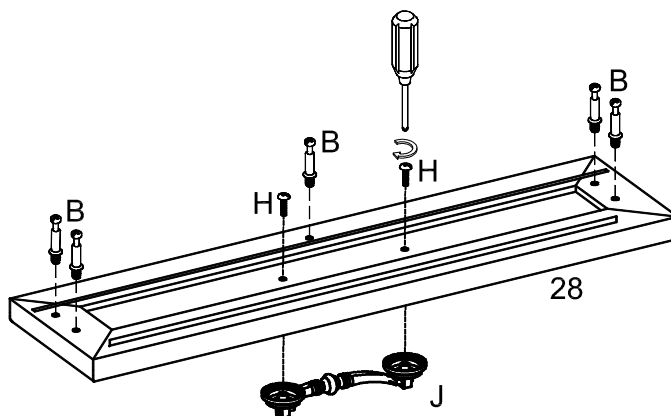

Step 44

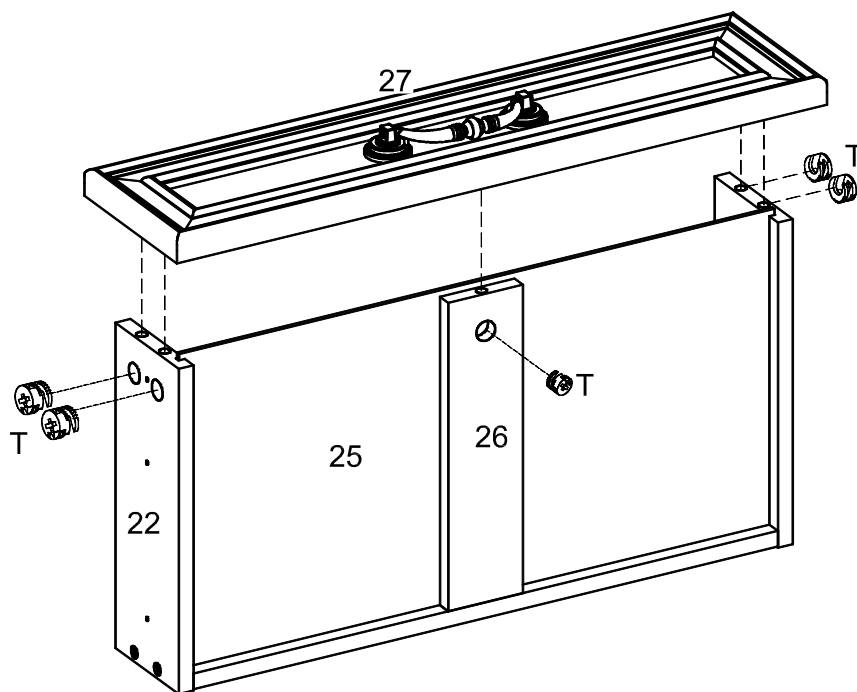

Small cam lock

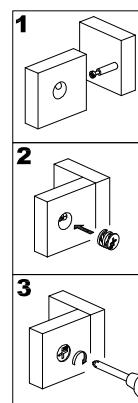

Step 45

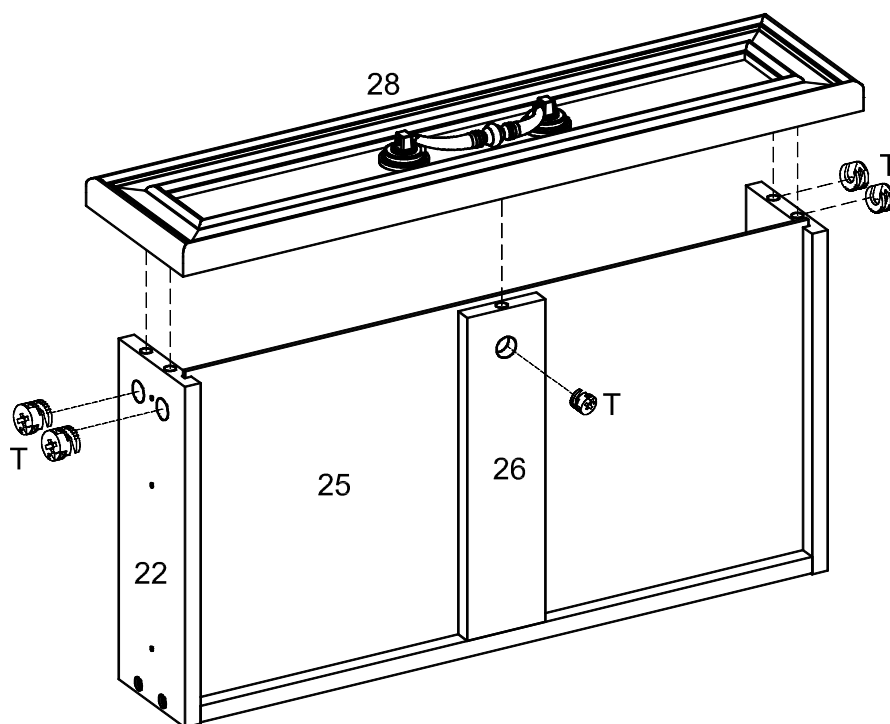

Small cam lock

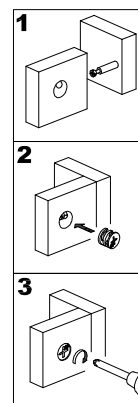

Step 46

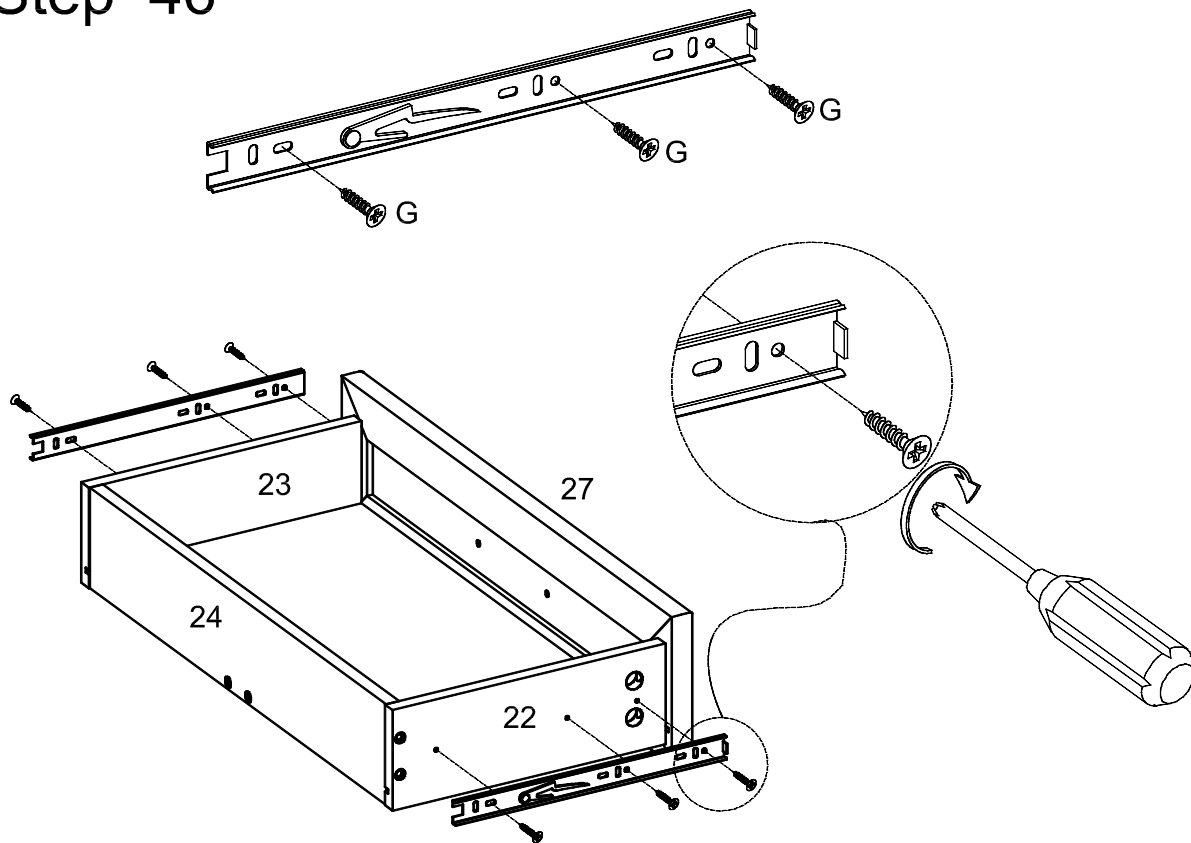

Step 47

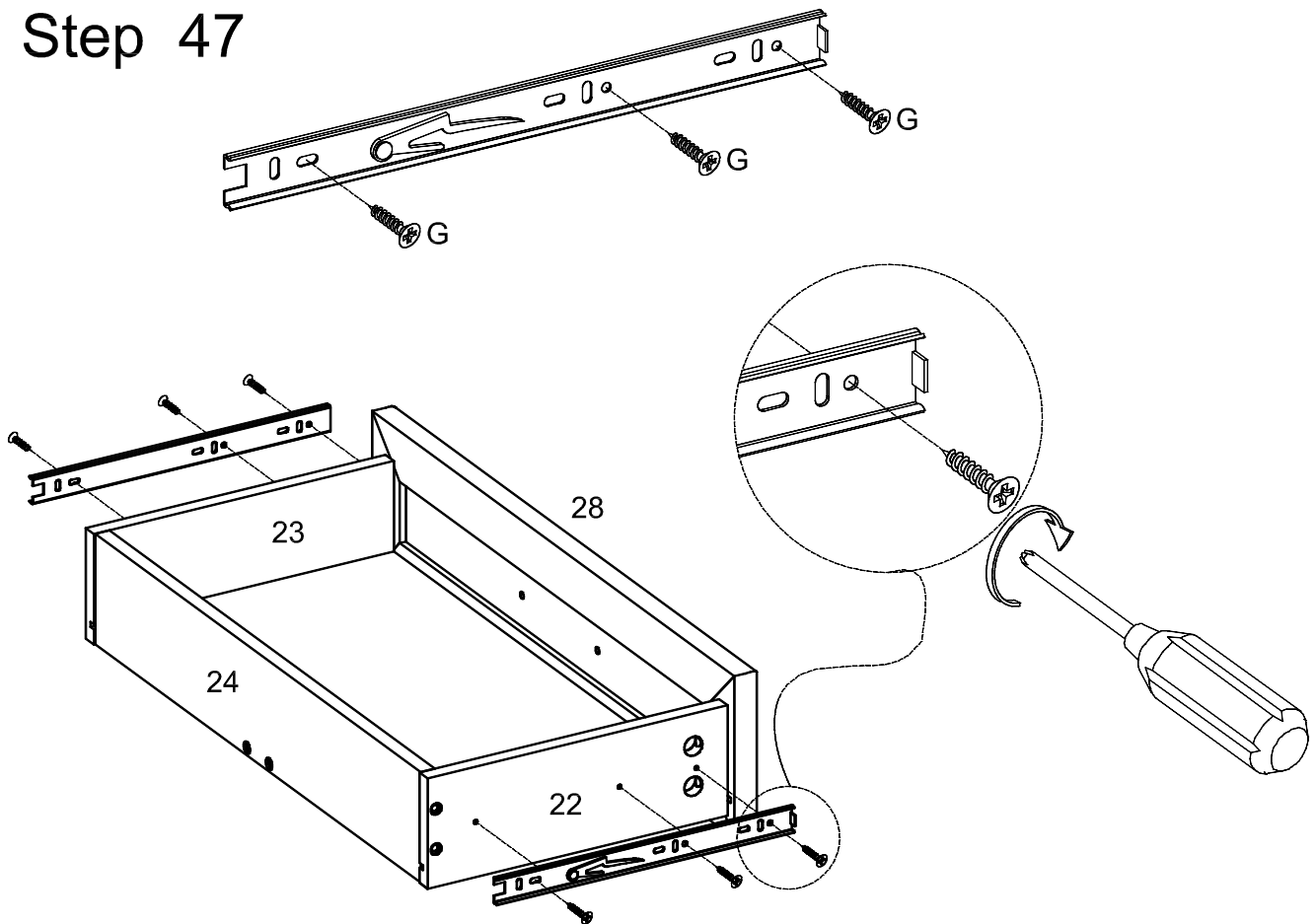

Step 48

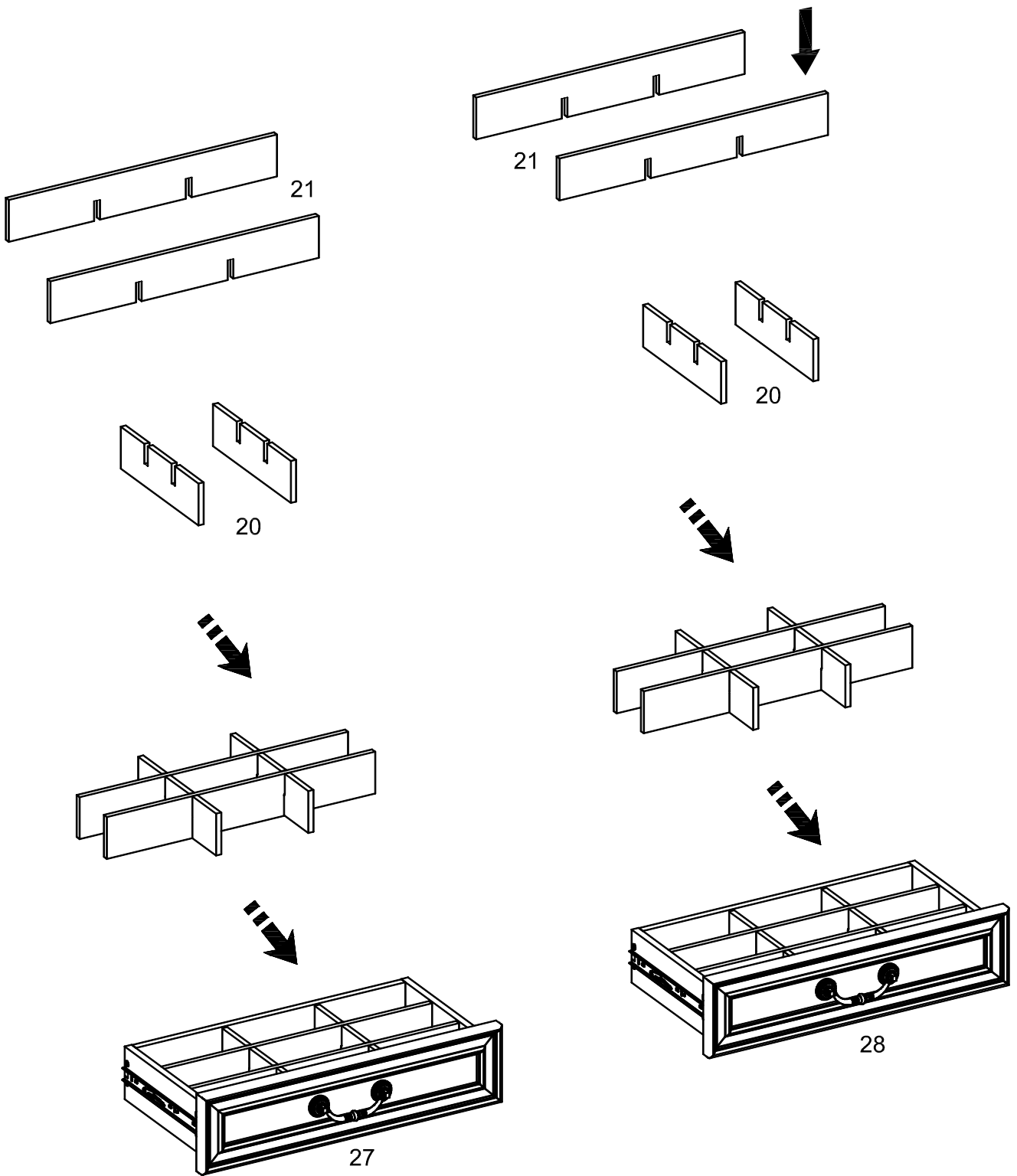

Step 49

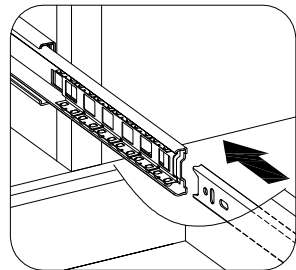
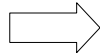
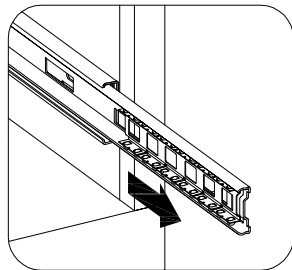
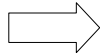
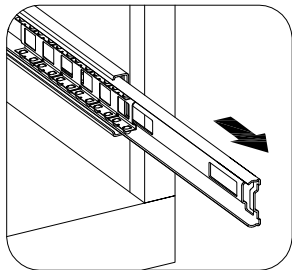
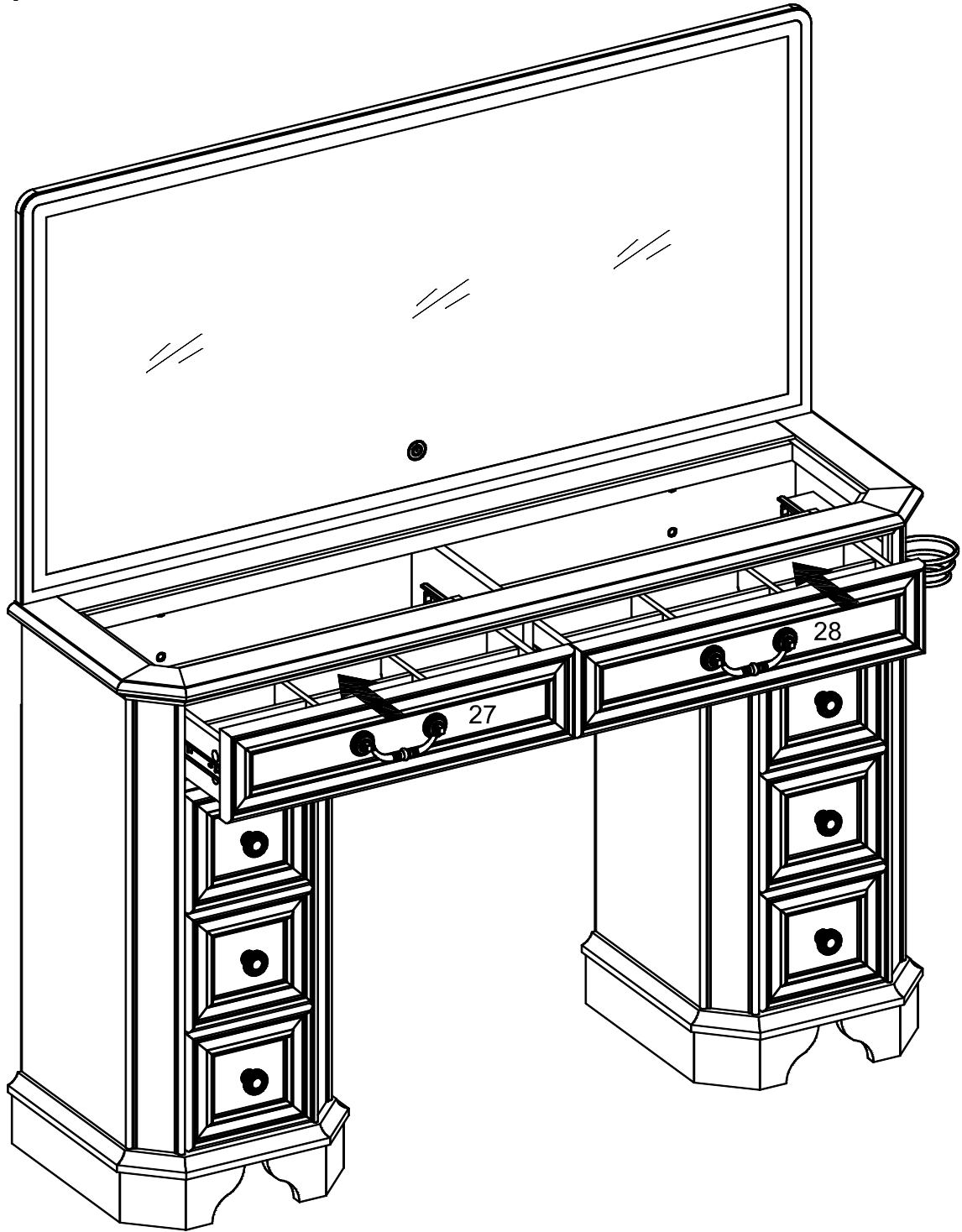

Step 50

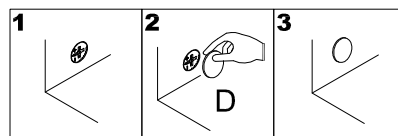
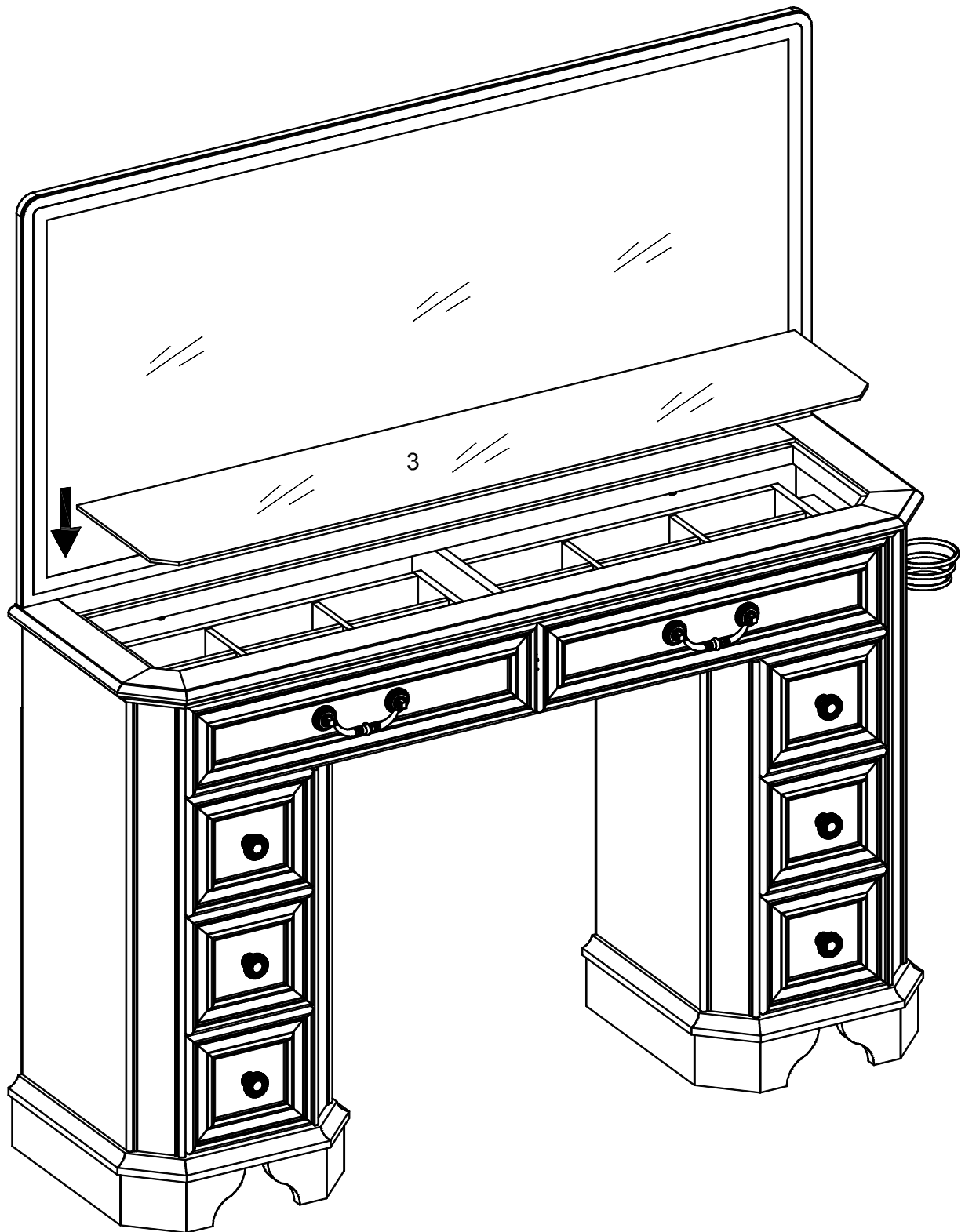

Step 51

Serious or fatal injuries can occur from furniture tipping over. To prevent the furniture from tipping over we recommend that it is permanently fixed to the wall. Wall anchor and hardware are included with this product. Please make sure hardware is suitable for your walls before installing, as different wall materials may require different types of anchors.

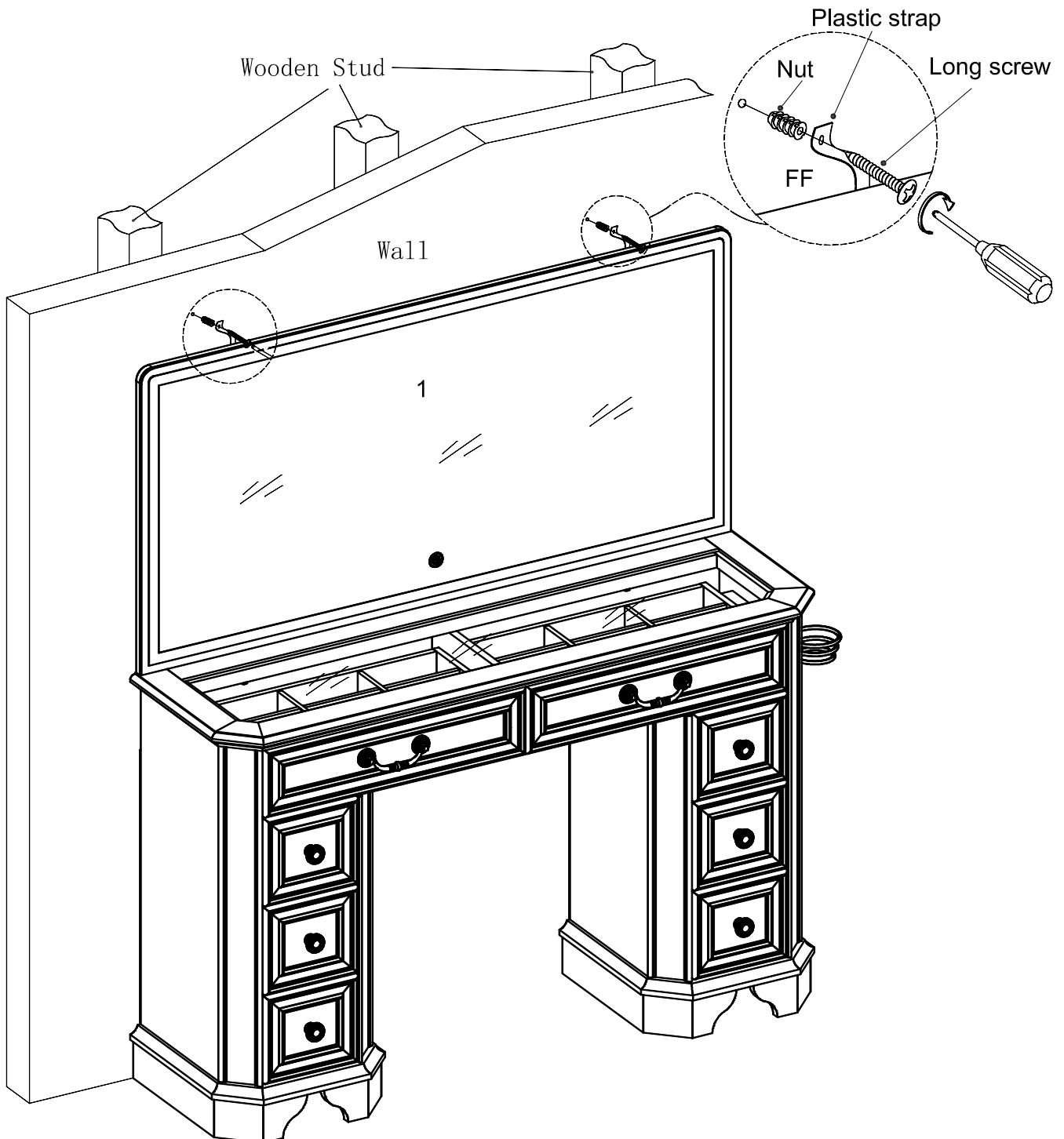
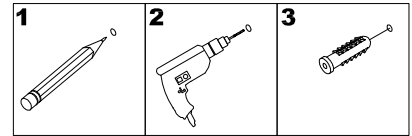

Step 52

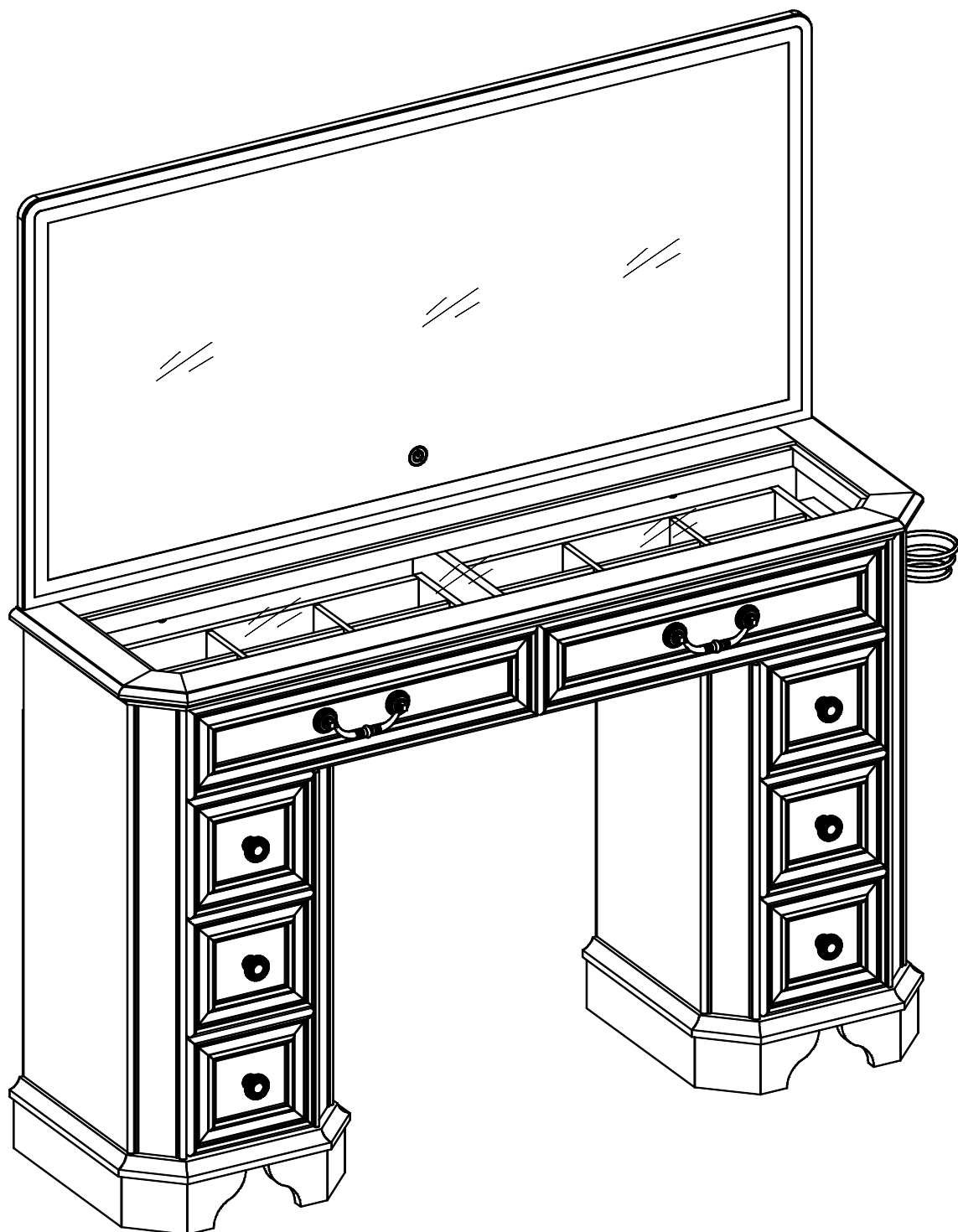

Final Assembly