



Parker Living
A Division of Parker House

Assembly Instructions Turner Recliner

BEFORE ASSEMBLY

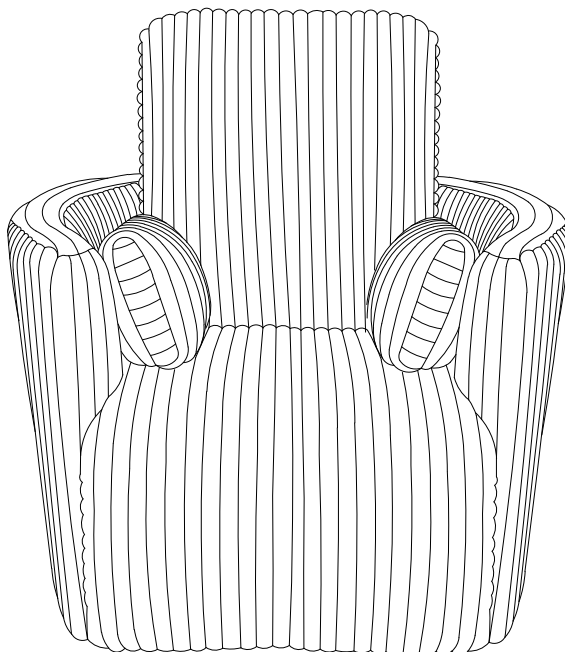

Thank you for purchasing this quality product. This product has been designed for easy assembly and constructed for durability. Please take the time to read and follow the assembly instructions carefully.

Manual Swivel Glider Recliner



Part List

When unpacking, please be careful not to discard any parts with the packaging. Before continuing, please make sure you have the following parts:

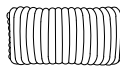
NO	Description	Sketch	Qty
A	Body		1 PC
B	Back cushion		1 PC
C	Pillow cushion		2 PCS

Step 1

Check the bottom of the Body (A) to cut and remove any fastener that is holding the mechanism in place during transportation.

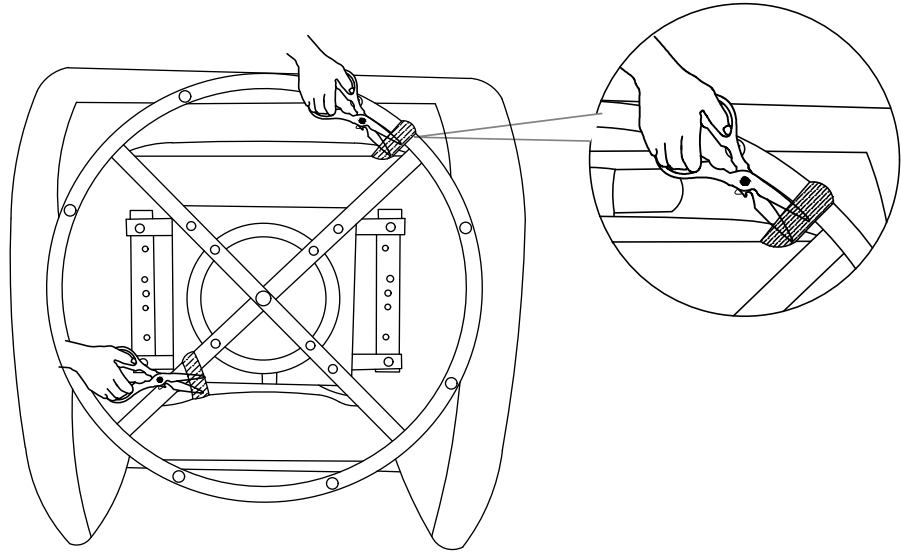

Step 2

Install the back cushion (B) into the body (A) by positioning the female metal receiver brackets over the male metal posts. Ensure that the female metal receives brackets on each side line up with the seat metal posts. Push the backrest down until each side is locked into place and an audible "click" is heard.

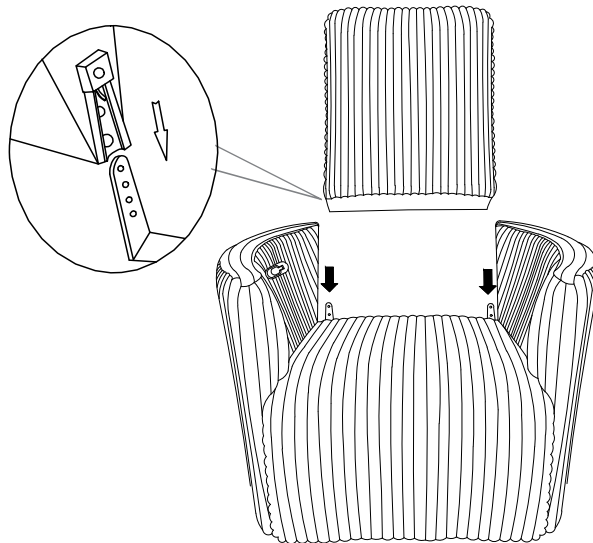

Step 3

Pillow cushions (C) are placed on either side of the seat armrests.

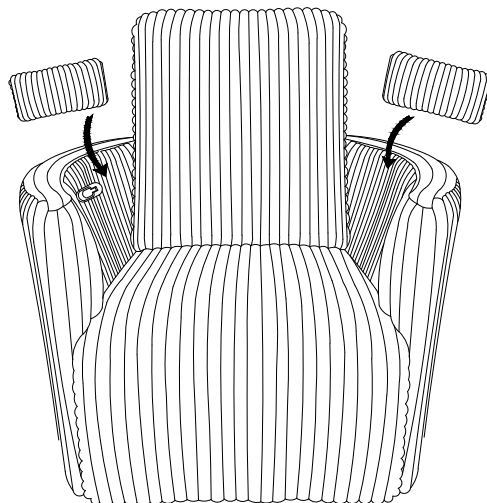

Step 4

1. Attach the flap to the seat frame by pulling the flap down, and pressing the bottom under the seat base, connecting the velcro.

2. Open the footrest by pulling the handle.

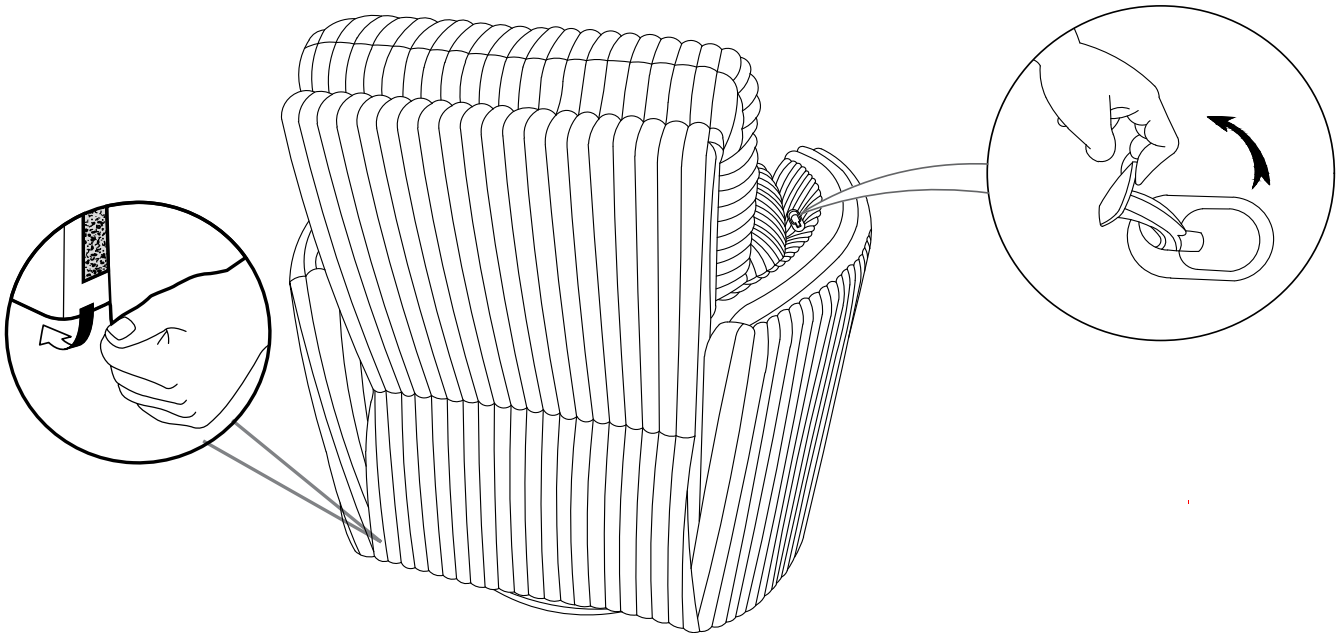

Function Display

