

ASSEMBLY INSTRUCTION

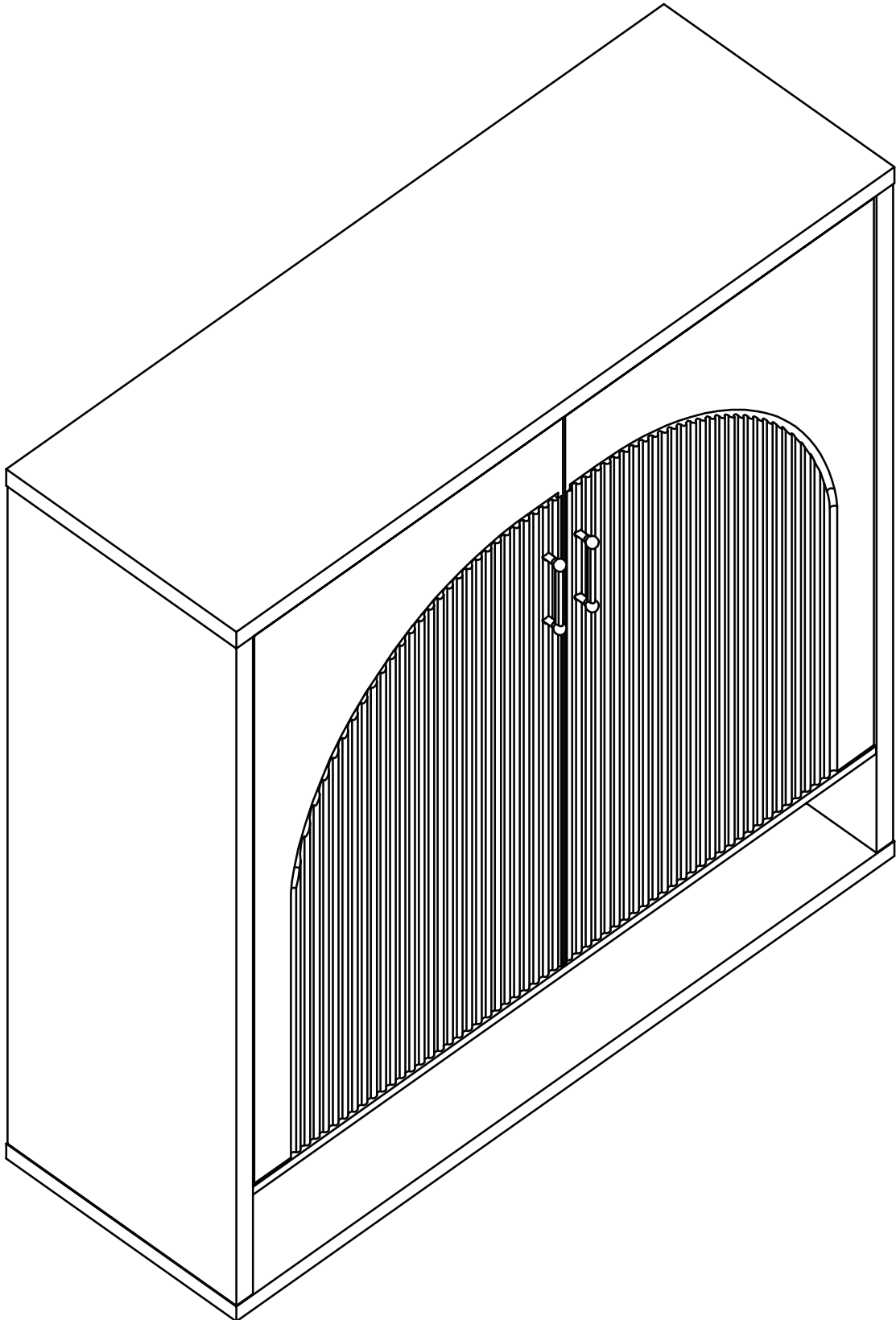

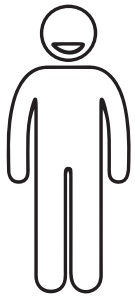

× 2

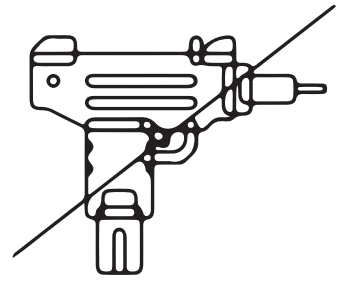
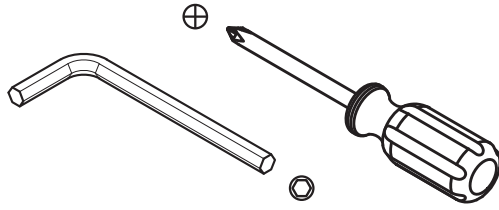

Before You Begin

Two people are recommended for the assembly.

Use the included tools.

If using a power tool, use low power and torque.

Installation of Eccentric Unit

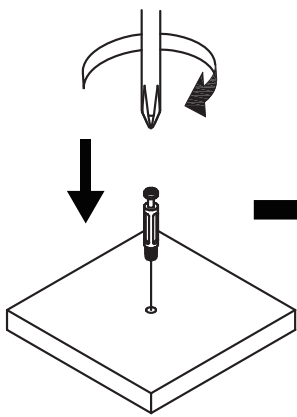
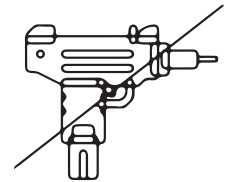
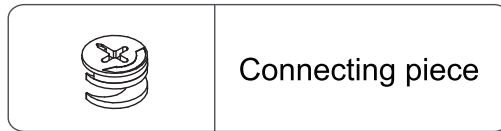

1

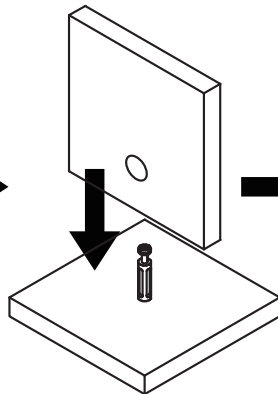

2

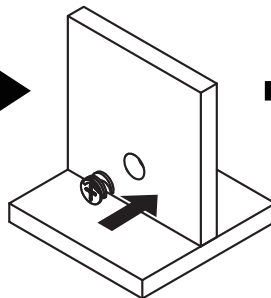

3

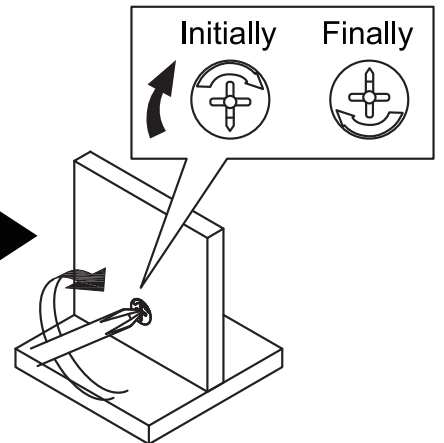



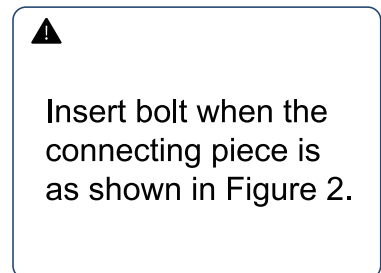
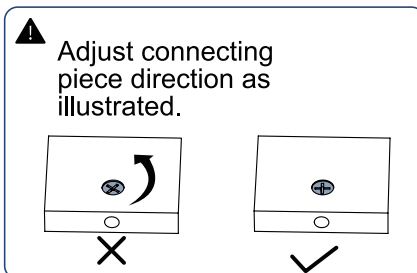
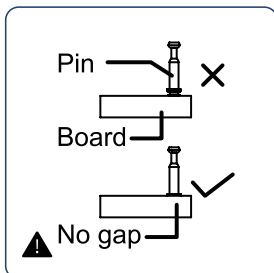

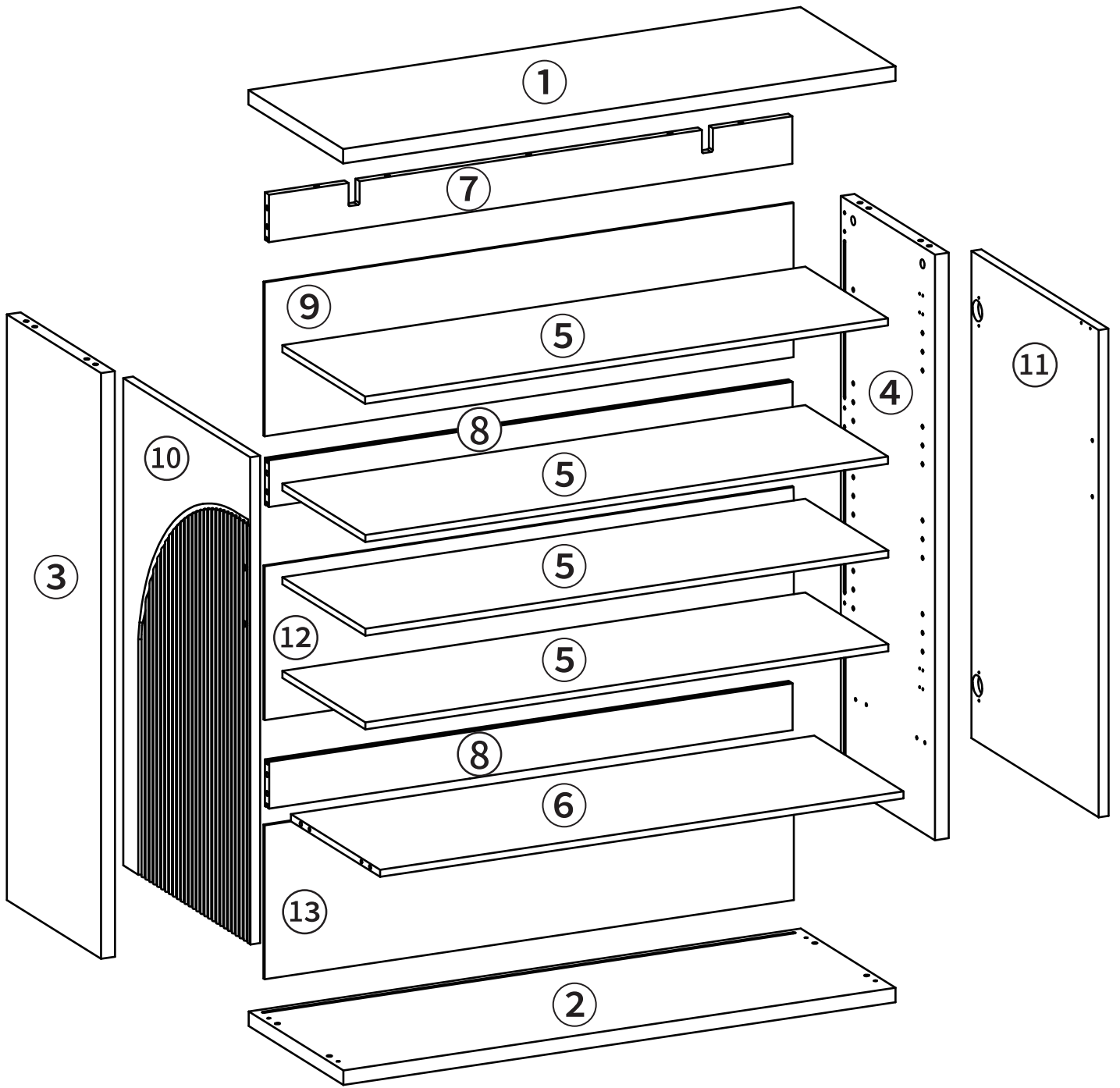









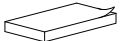

4

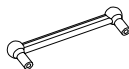

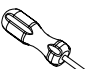

Package Contents: Hardware *Please count and verify all parts before assembly.*

A×20 +2	B×20 +2	C×15+2	D×4+2	E×12 +1	F×16+1	G×44+2	H×4+1	I×4+1
 M6x27.5mm	 Φ12mm	 Φ8x40mm	 M6.3 x50mm	 14x14x9mm	 M3.5x14mm	 M3.5x14mm		 Φ20
J×2	K×2	L×4+1	M×4	N×2+2	O×2+1	P×2+1	Q×2	
 J1  J2		 M4x18mm		 M4x12mm	 M4x40mm			

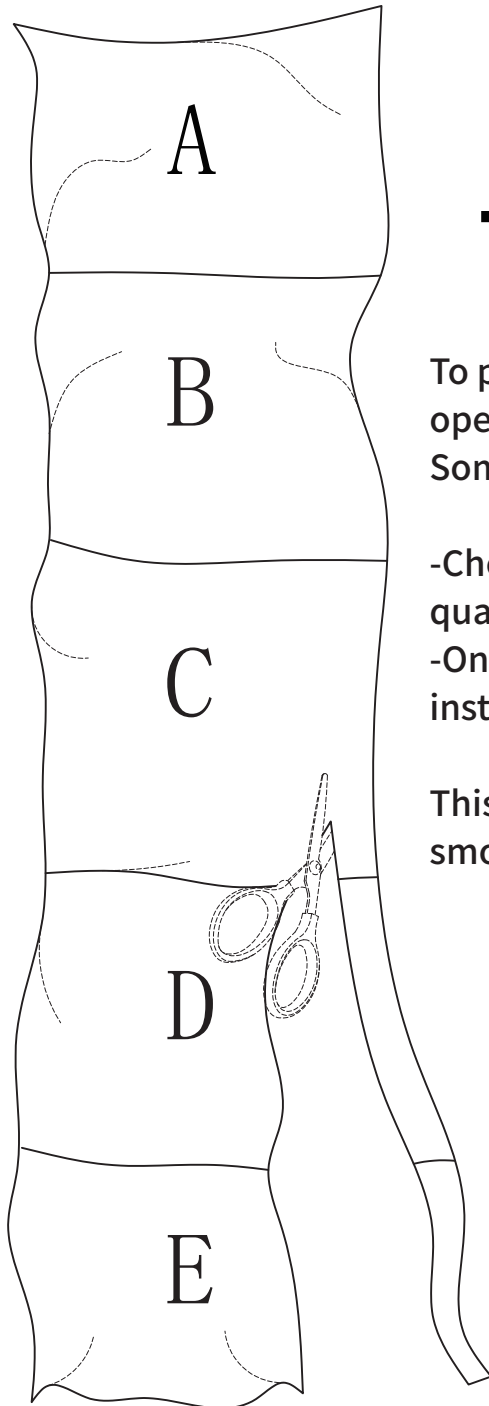
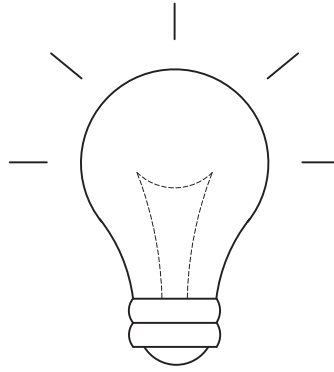

friendly reminder



To prevent confusion during installation, please do not cut open all hardware bags at once.
Some screws may look similar, so before starting assembly:

- Check each hardware bag and confirm that the type and quantity match the parts list in the manual.
- Only open each bag when it is needed for that specific installation step.

This will help keep the hardware organized and ensure a smoother installation process.

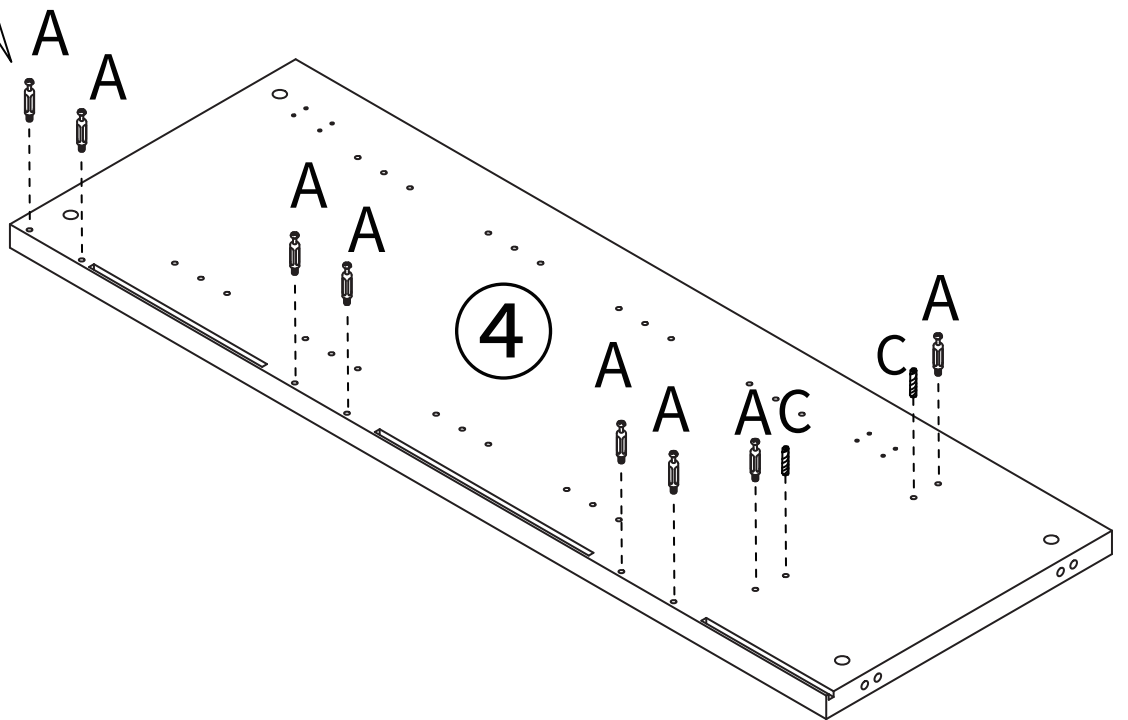
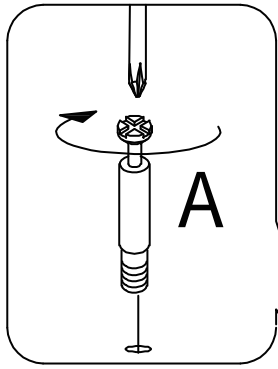
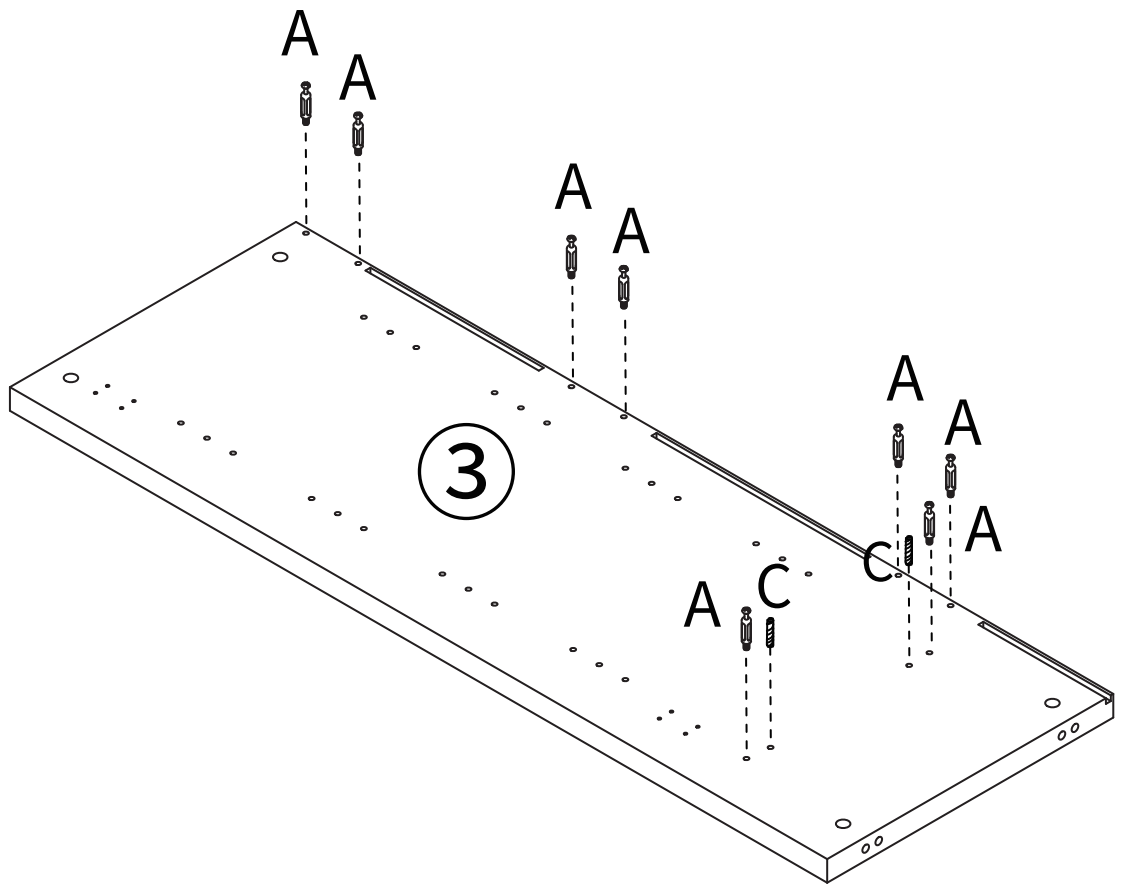
1

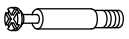

A × 16	C × 4
	
M6x27.5mm	Φ8x40mm

Screw (A) into (3) and (4).
Insert (C) into (3) and (4).

2

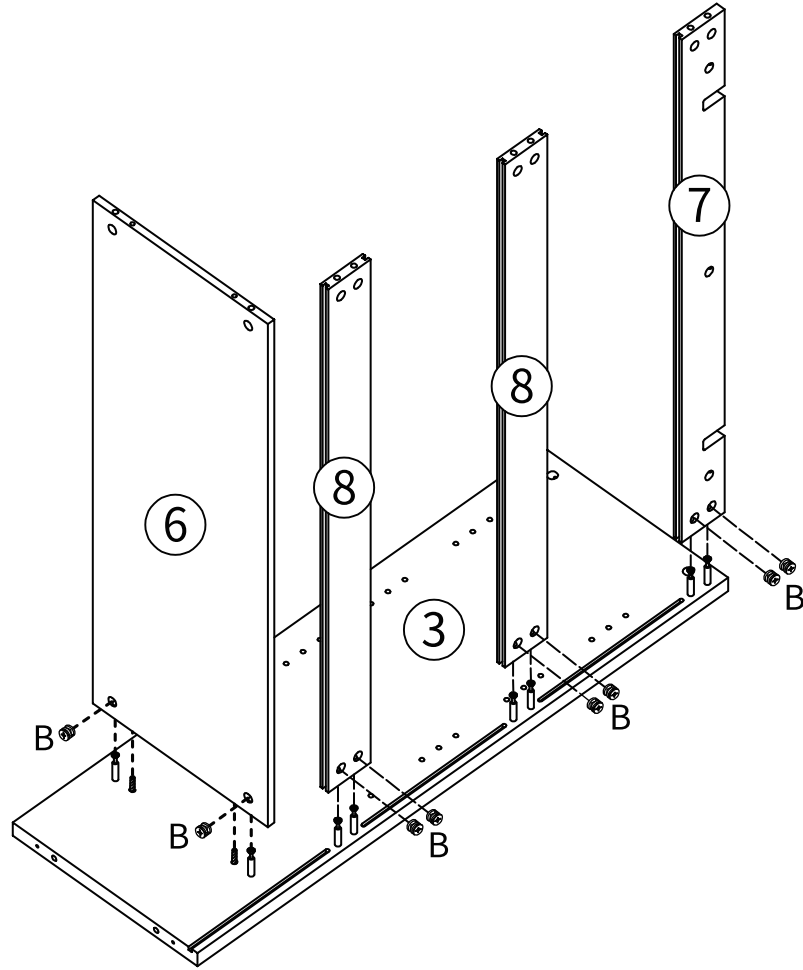

B×8



Φ12mm

Insert (6) (7) and (8) into (3), securing them with (B).

3

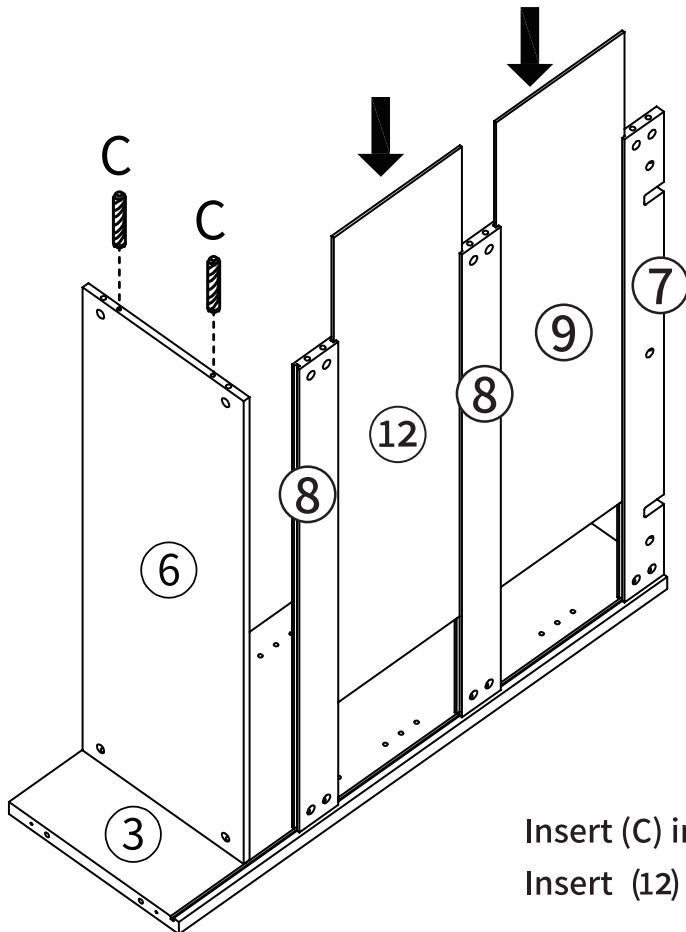

C×2



Insert (C) into (6)

Insert (12) (9) into the grooves of (8) and (7).

4

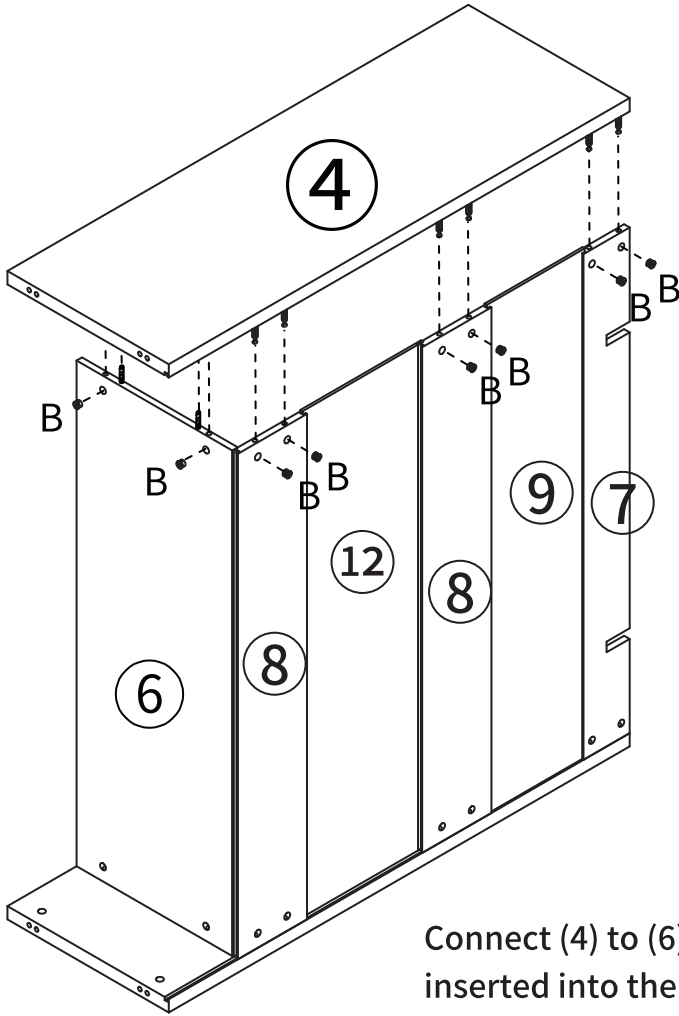

B×8



Φ12mm

Connect (4) to (6) (7) and (8) while ensuring (9)(12) is inserted into the groove of (4). Secure them with (B).

5

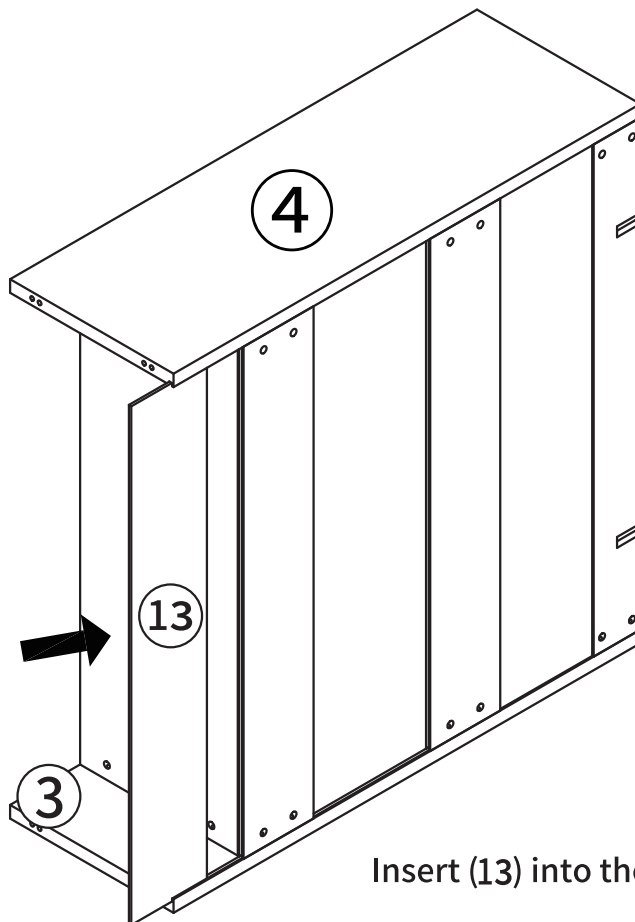

Insert (13) into the grooves of (3) and (4).

6

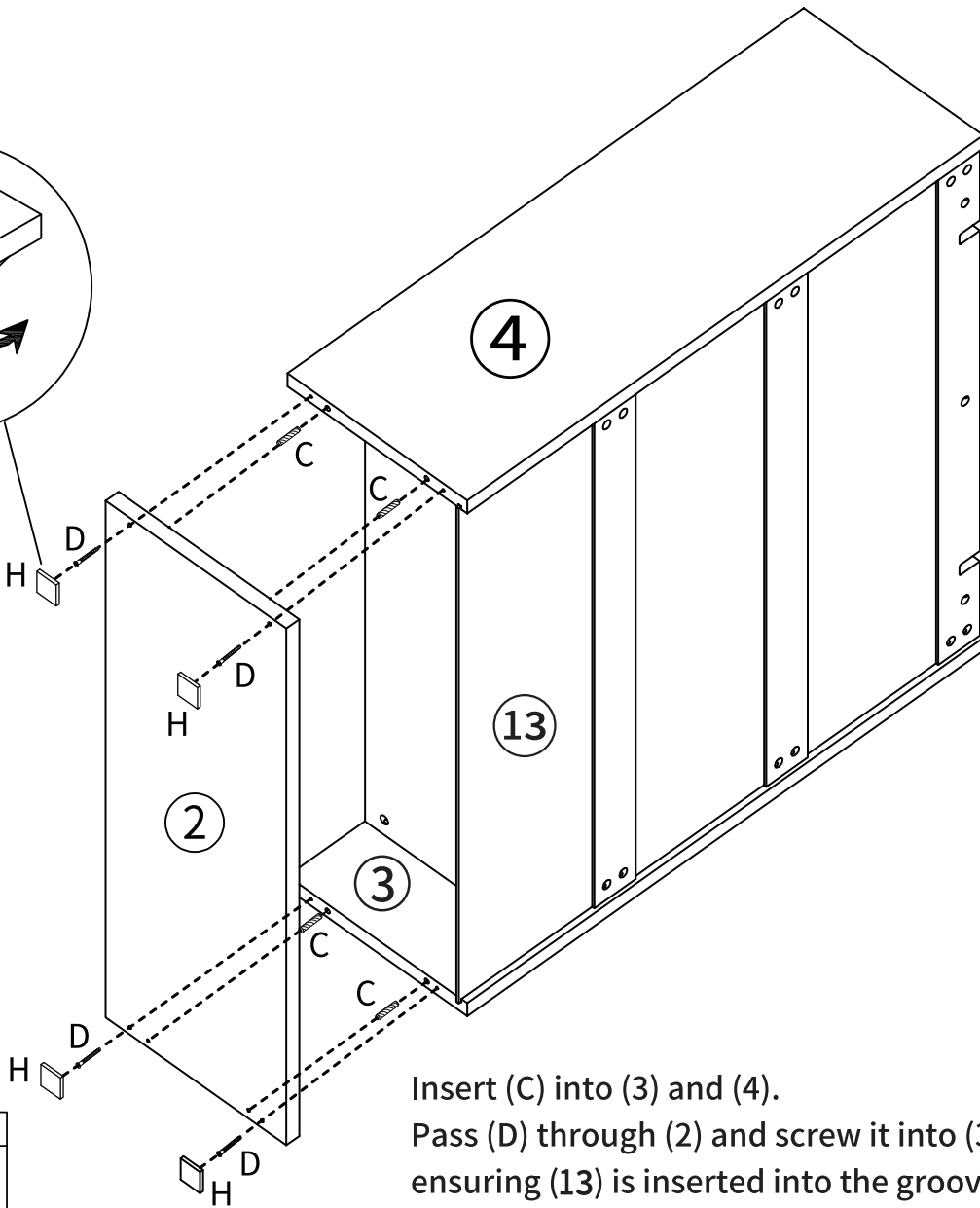
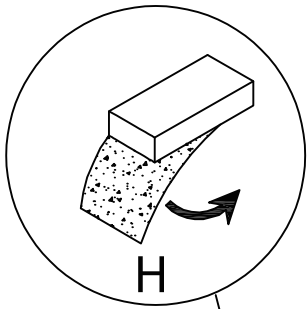

H×4



C×4

D×4



Φ8x30mm

M6.3 x50mm

Insert (C) into (3) and (4).
Pass (D) through (2) and screw it into (3) and (4), ensuring (13) is inserted into the groove of (2).
Peel off the adhesive on (H) and apply it over (D).

7

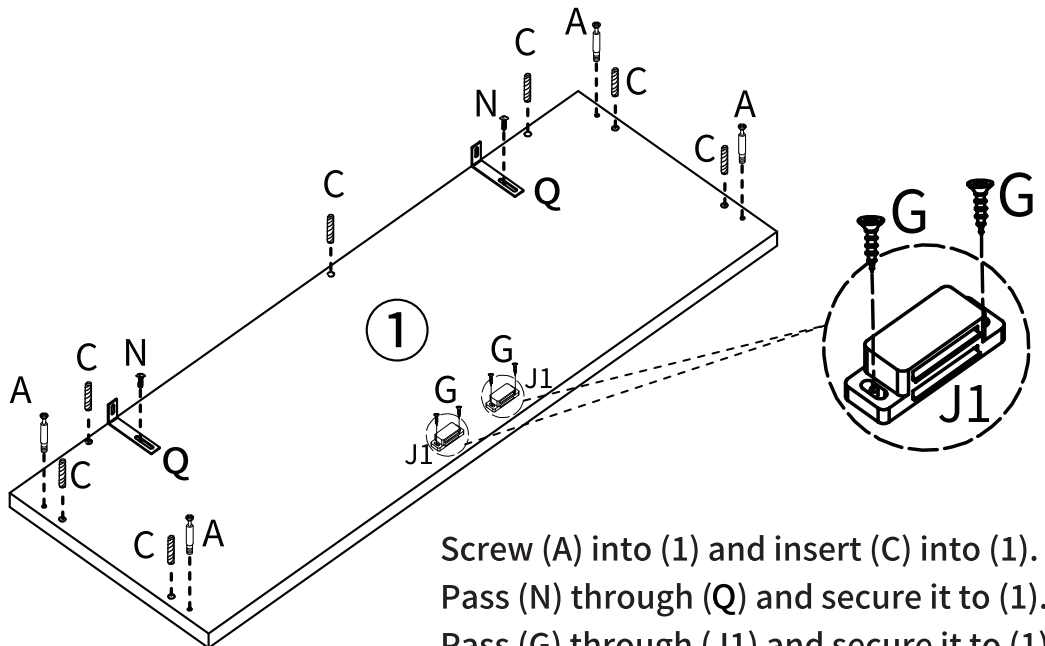

J1×2	N×2	Q×2
------	-----	-----



M4x12mm

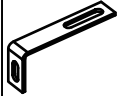

A×4	C×7	G×4
-----	-----	-----



M6x27.5mm

Φ8x40mm

M3.5x14mm

Screw (A) into (1) and insert (C) into (1).
Pass (N) through (Q) and secure it to (1).
Pass (G) through (J1) and secure it to (1).

8

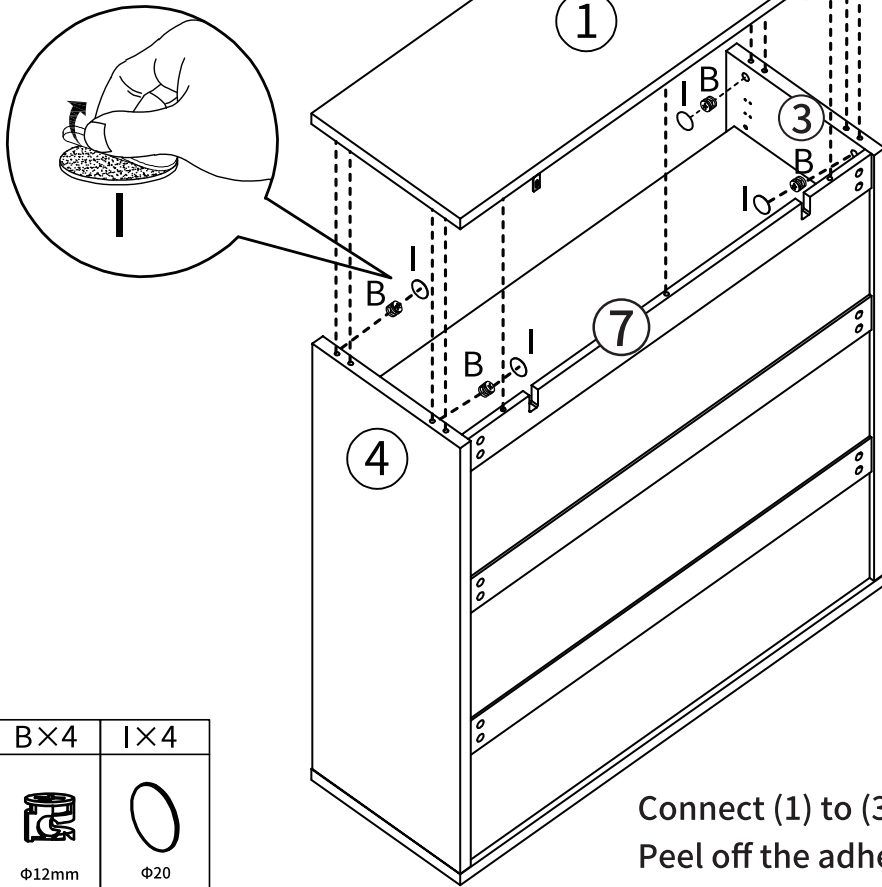

B×4

I×4



Φ12mm



Φ20

Connect (1) to (3) (4) and (7), securing them with (B).
Peel off the adhesive on (I) and apply it over (B).

9

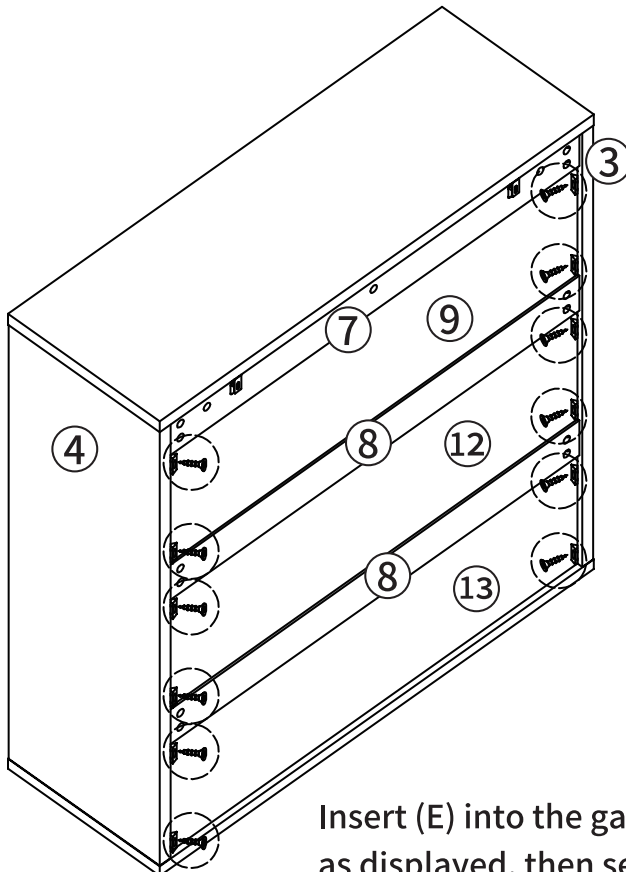

E×12

G×12



M3.5x14mm

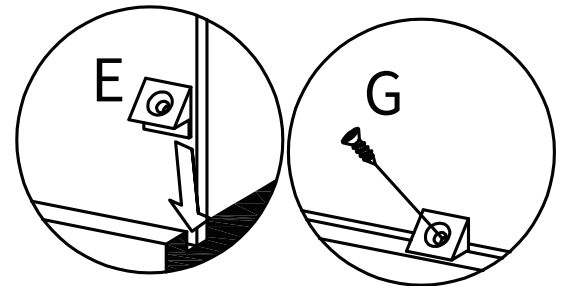

Insert (E) into the gaps formed by (3) (4) (7) (8) and (9)(12)(13),
as displayed, then secure it with (G) through (E).

10

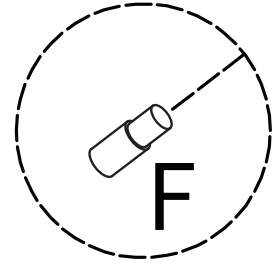
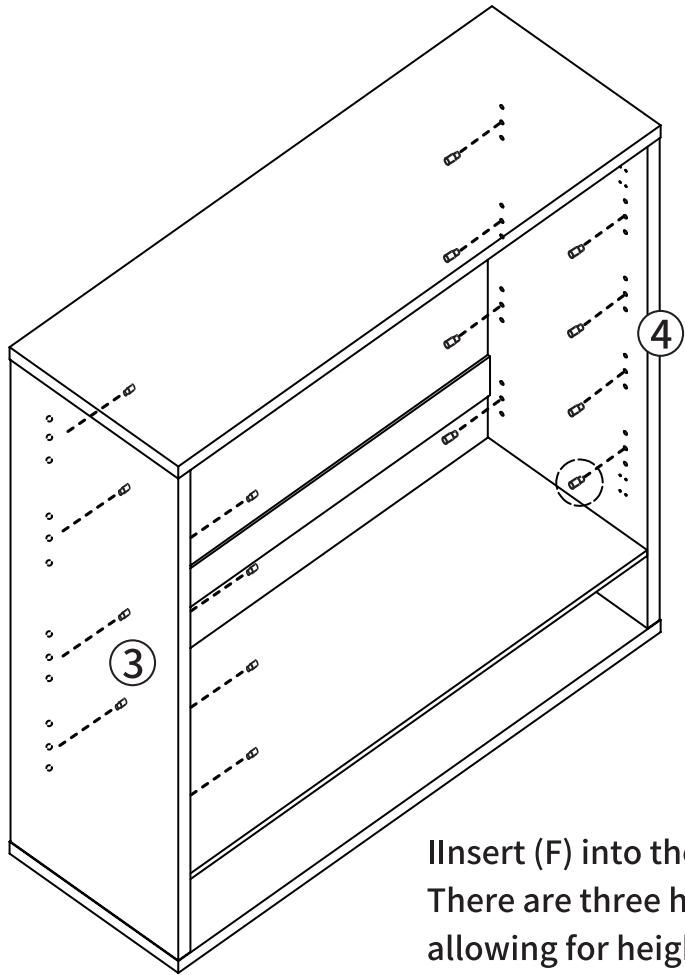

F×16



Insert (F) into the small holes on (3) and (4). There are three hole positions available, allowing for height adjustment as needed.

11

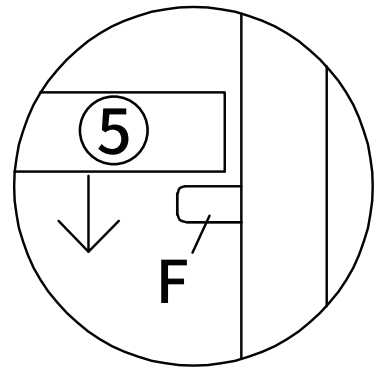
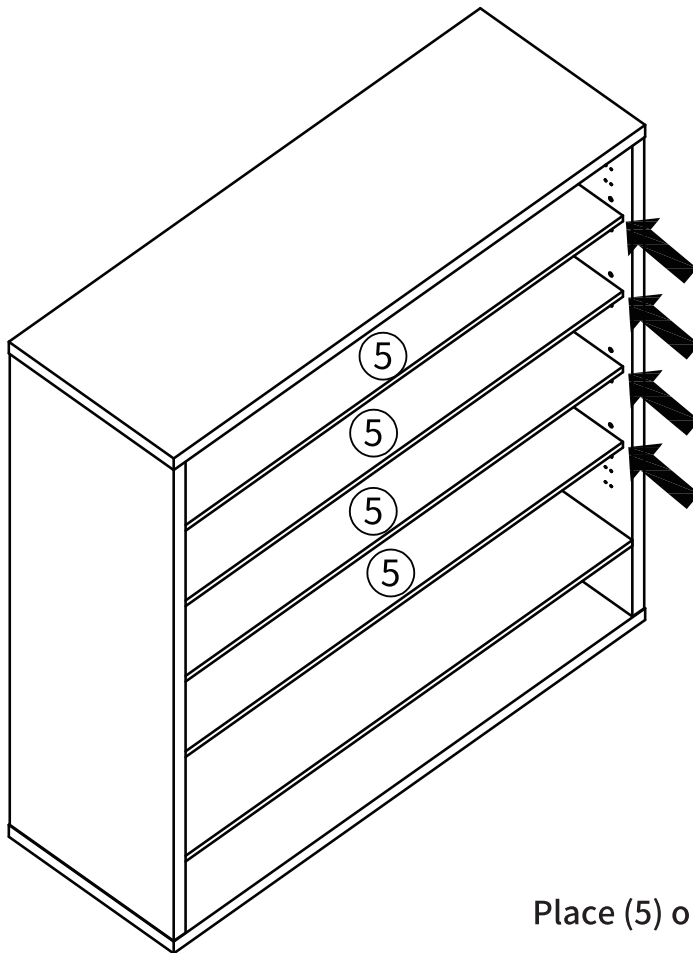

Place (5) on (F).

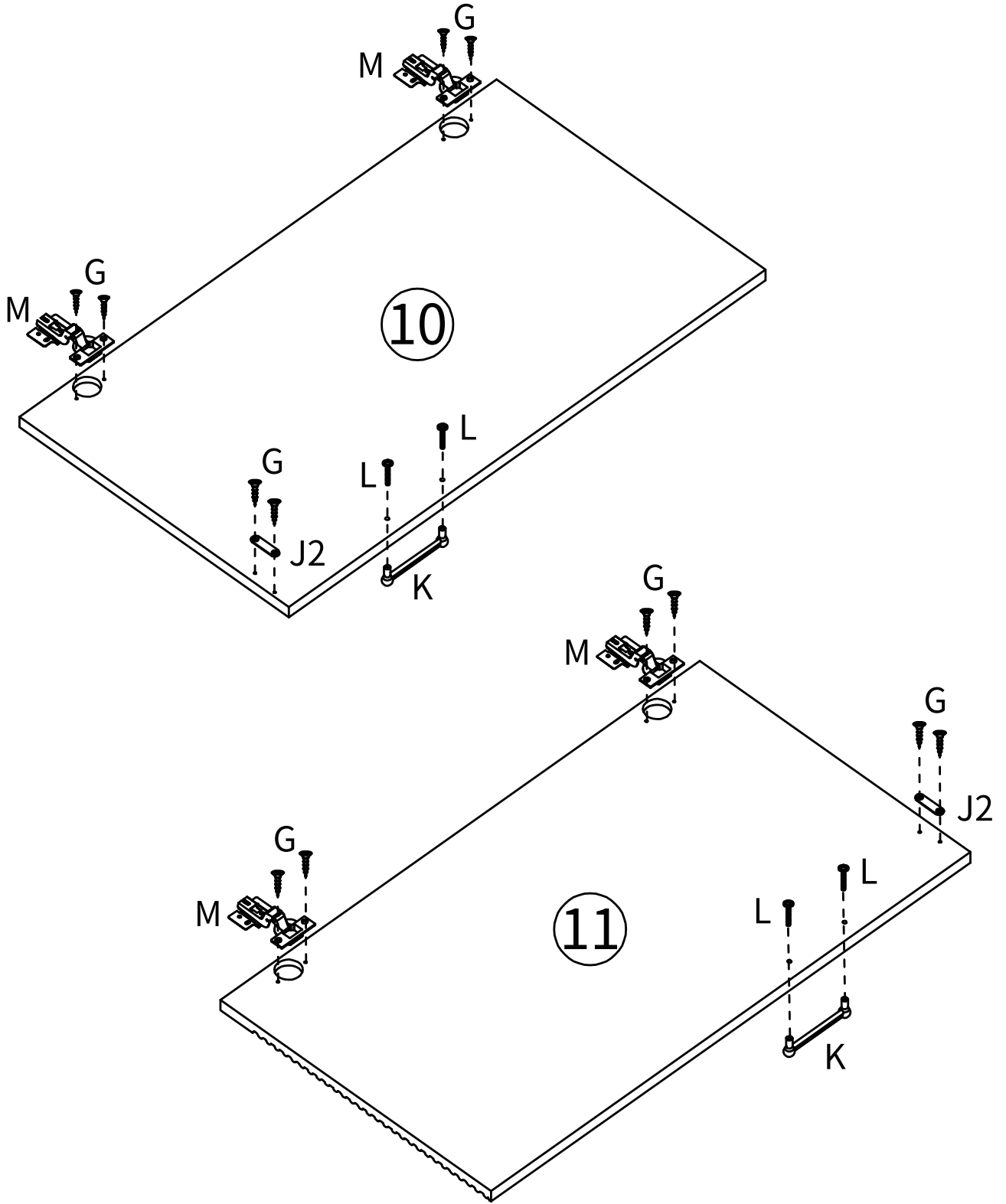

J2×2	G×12	K×2	L×4	M×4
	M3.5x14mm		M4x18mm	

Pass (G) through (J2) and secure it to (10) and (11).
 Pass (G) through (M) and secure it to (10) and (11).
 Connect (K) with (11) and (10) by securing (L).

13

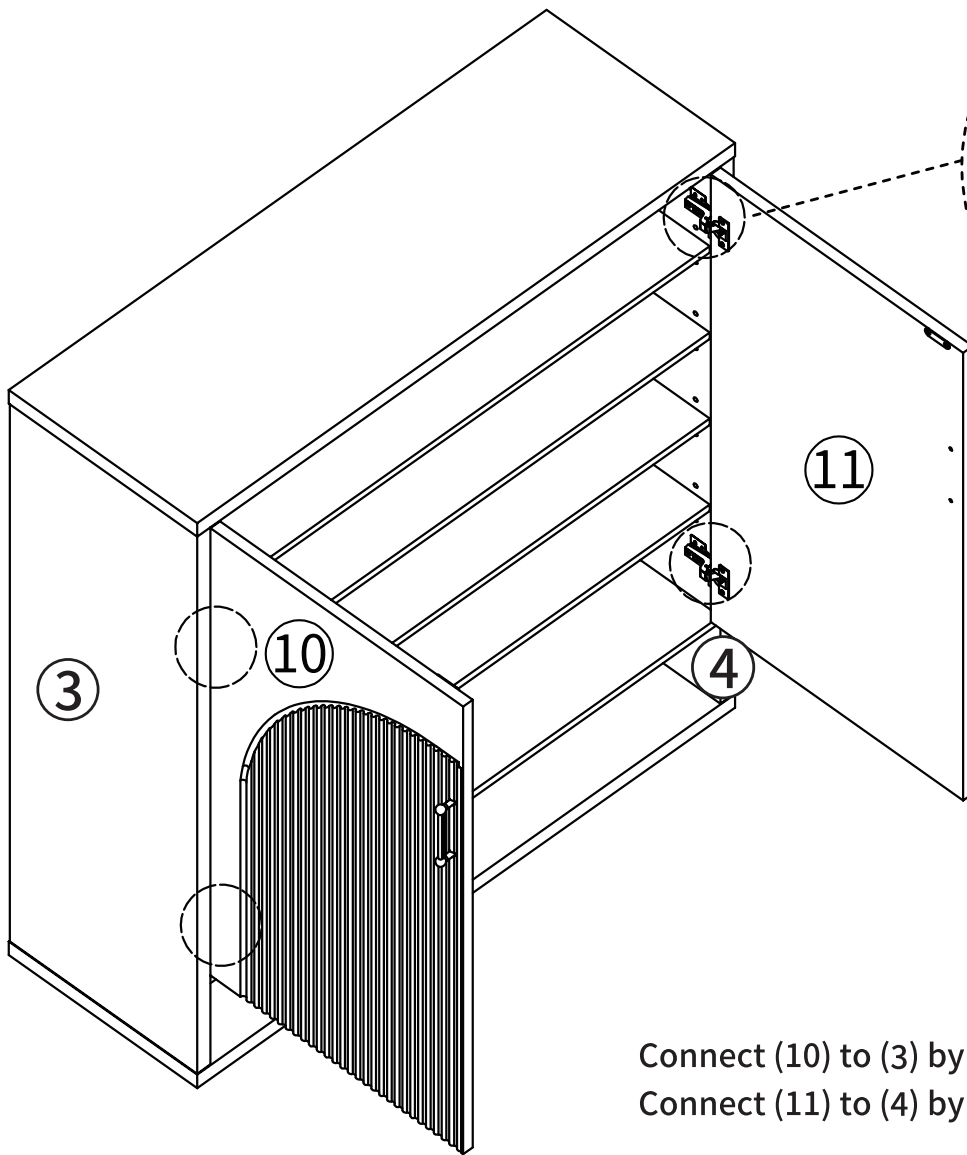

Gx4 M

Gx16



M3.5x14mm

Connect (10) to (3) by securing (G) through (M).
Connect (11) to (4) by securing (G) through (M).

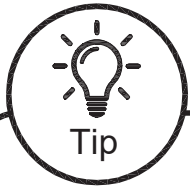

Tip

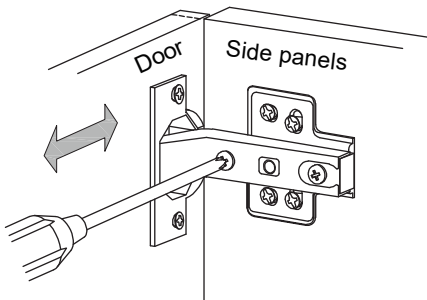

Adjust horizontal width
with this screw.

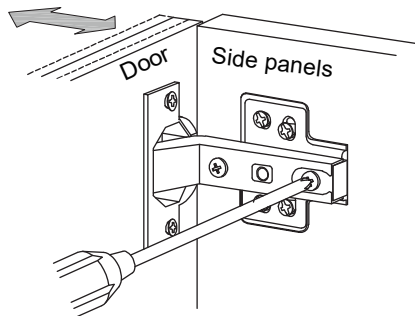

Adjust depth position
by loosening the hinge arm
mounting screw.

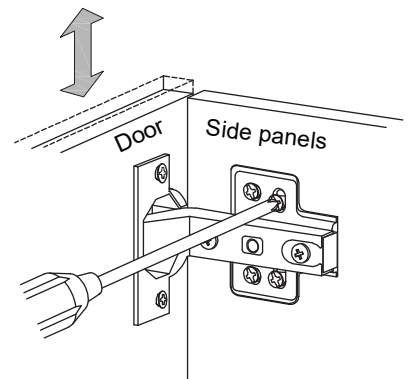

Adjust vertical height
via the screws in the
mounting plate.

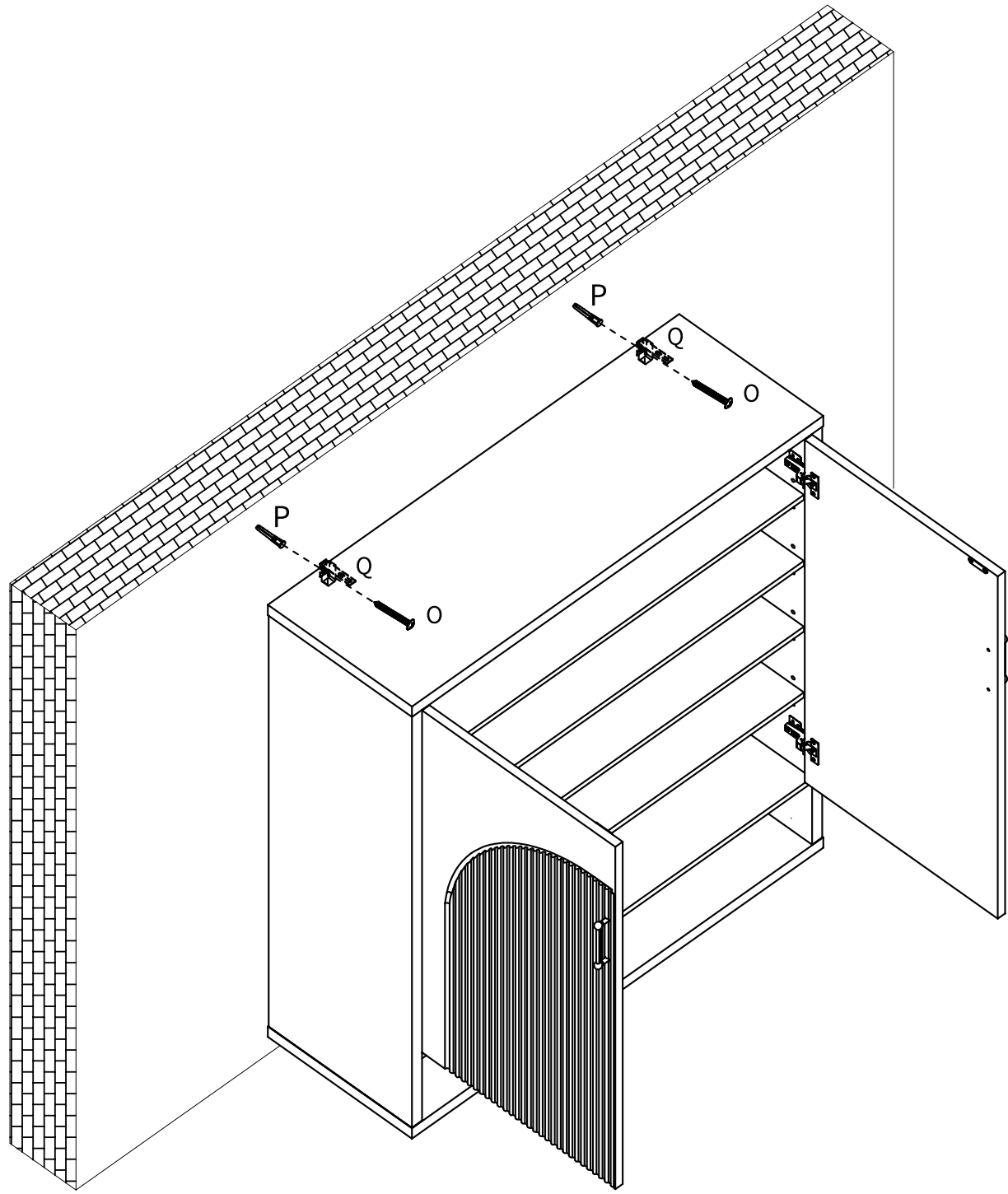
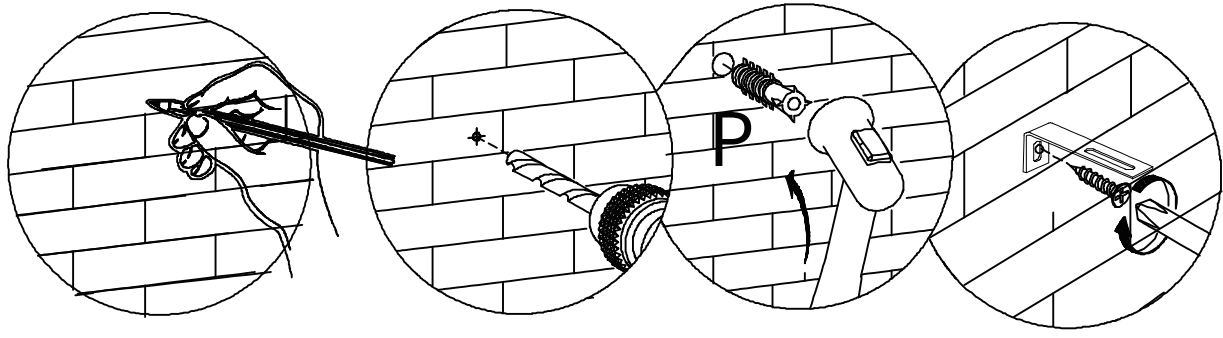

P×2	O×2
	M4x40mm

Mark the drilling position on the wall, drill a hole, and insert (P).
Pass (O) through (Q) and twist it into (P).

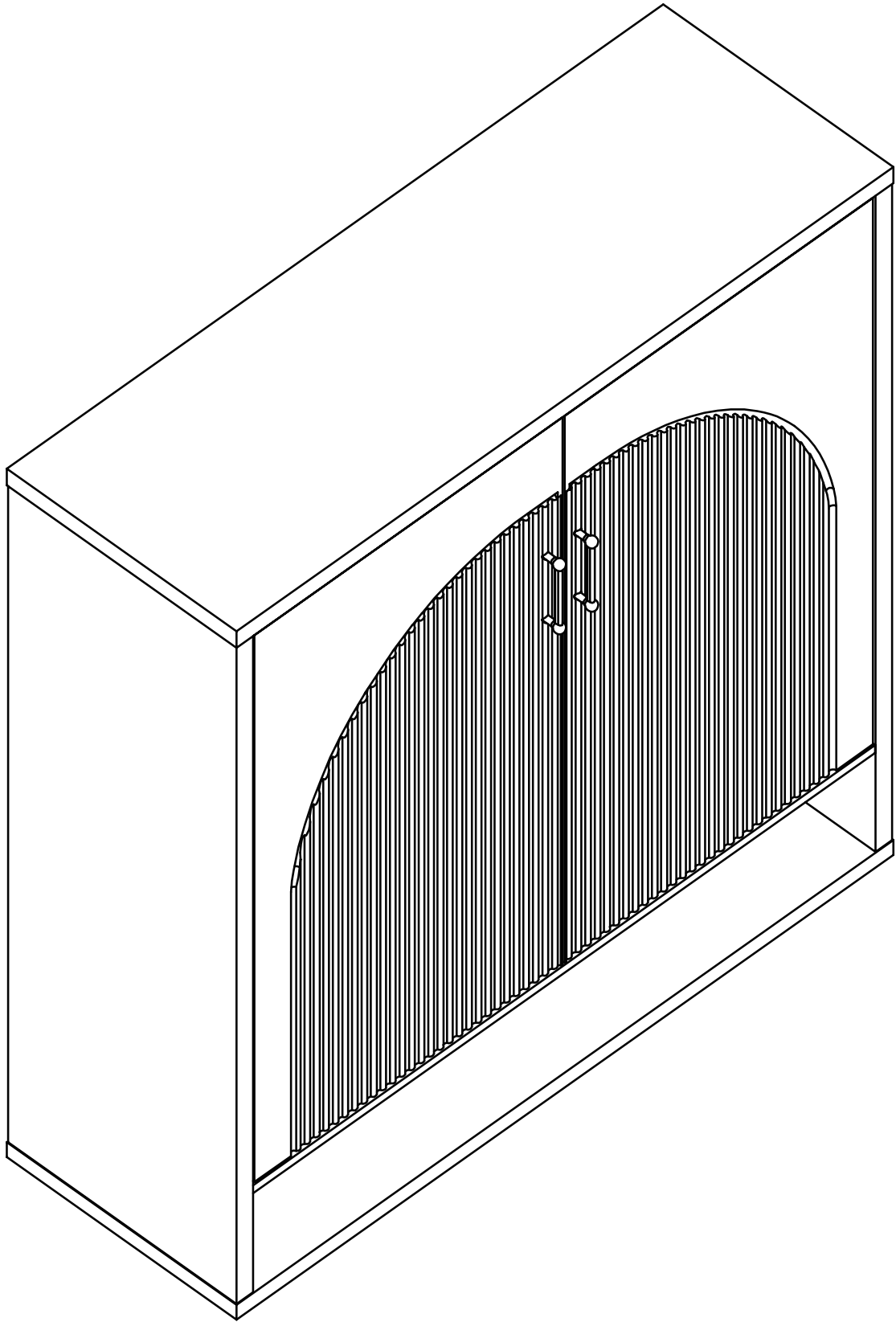

Assembly complete!