

Upholstered bed

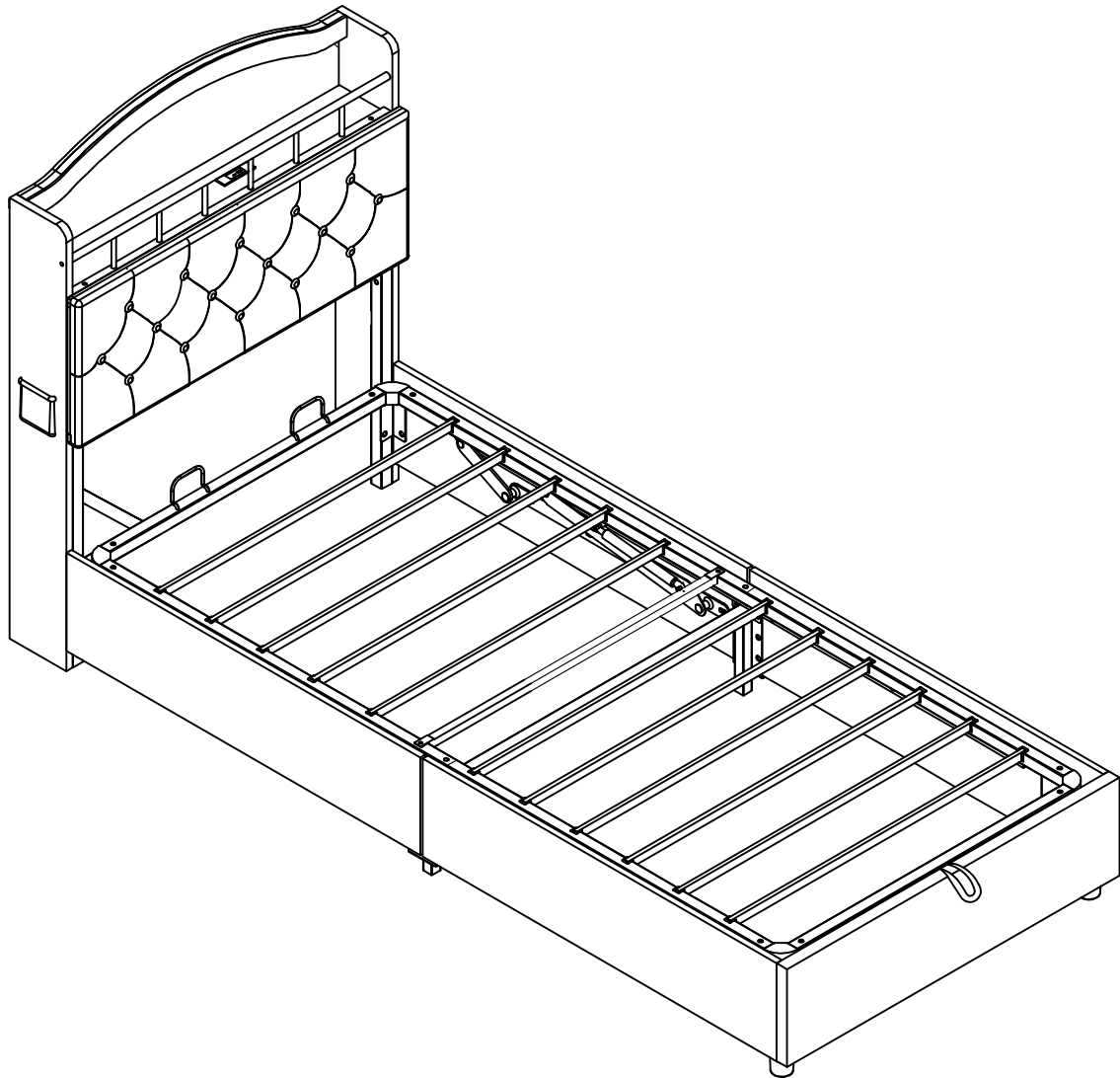

N652P361440P N652P361441P
90*190



TIPS

1.This product is divided into 2 parcels for delivery. They may not arrive at the same time. Please wait patiently.

2.Please read the instructions fully before assembly. These instructions include important information which could ensure correct assembly. We have been working on providing high quality products for you. However, in the rare instance that your product is defective,missing parts or there are some issues, please don't hesitate to contact our customer service to submit parts requirements, assembly suggestion,or warranty claims, and we will give the best solution as soon as possible. If necessary, we need you to provide some more clear pictures of the issue.

3.Insert the screws in holes and tighten the screws, but not too tight, 70%~80% is ok,

finally tighten all the screws. If some issues happened that some screws can not target to the hole or some parts are difficult to install, please adjust the tightness of the screws.

4.2 people are recommended to finish.

SKU: N652P361441P

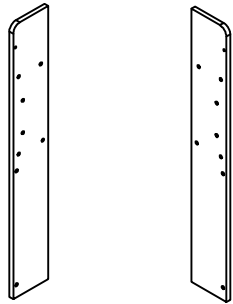

2
X1

3
X1

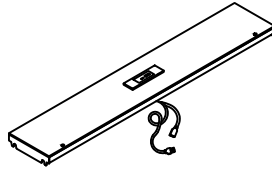

5
X1

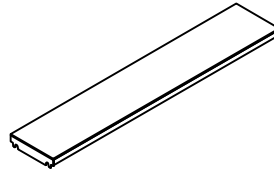

7
X1

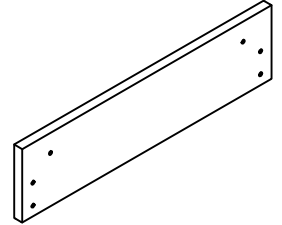

8
X1

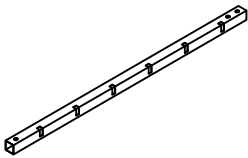

19
X1

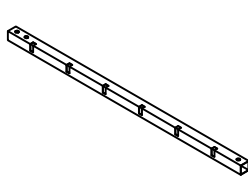

18
X1

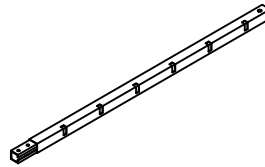

20
X1

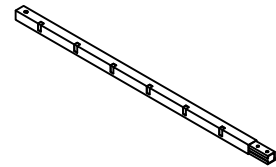

21
X1

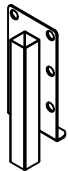

24
X2

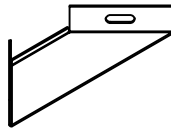

25
X2

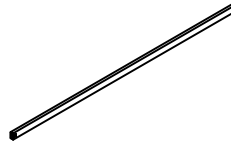

26
X12



28
X2



30
X2



32
X2

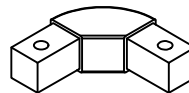

34
X4

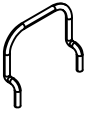

35
X2



37
X1



38
X1

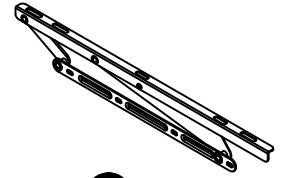

R
X1

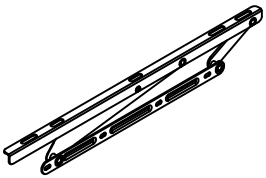

L
X1

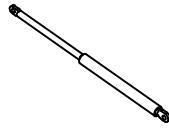

Z
X2

SKU:N652P361440P

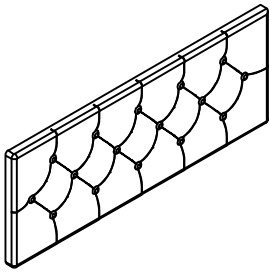

1
X1

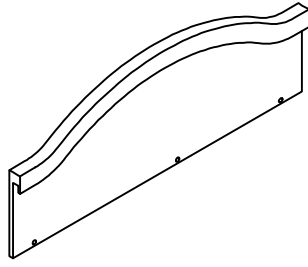

4
X1

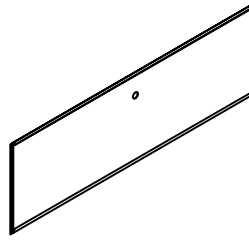

6
X1

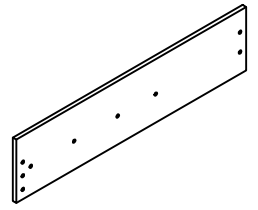

9
X1

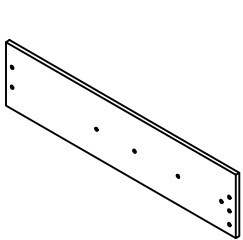

10
X1

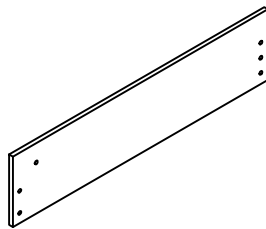

11
X1

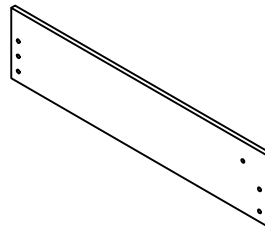

12
X1

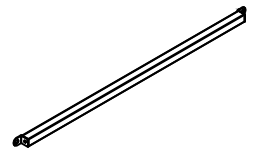

14
X1



15
X1



16
X1

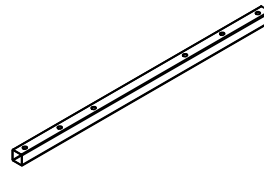

17
X2

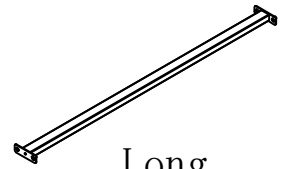

Long
22
X1

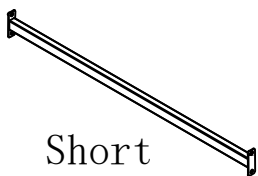

Short

23
X1

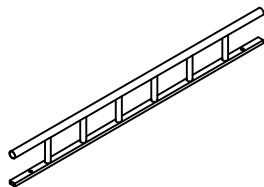

27
X1



36
X1

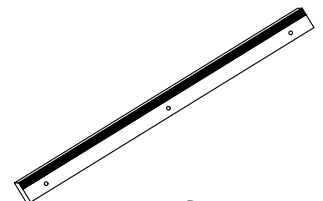

47
X1

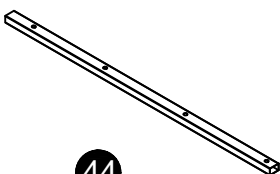

44
X2

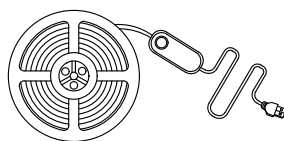

LIGHT STRIP
43
X1



REMOTE CONTROL
45
X1

SKU:N652P361440P

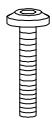

A

M6*35 (white)
X2+1

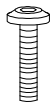

B

M6*25 (white)
X2+1

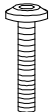

C

M6*15
X12+2

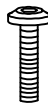

D

M6*25
X6+1

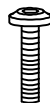

E

M8*15
X14+2

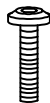

F

M8*20
X53+6

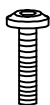

I

M8*45
X4+1

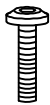

G

M8*25
X11+2



M

X1
M5

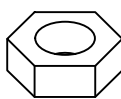

N

X4
M8

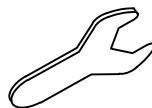

O

X1
M8



46

X2

Assembly Instruction

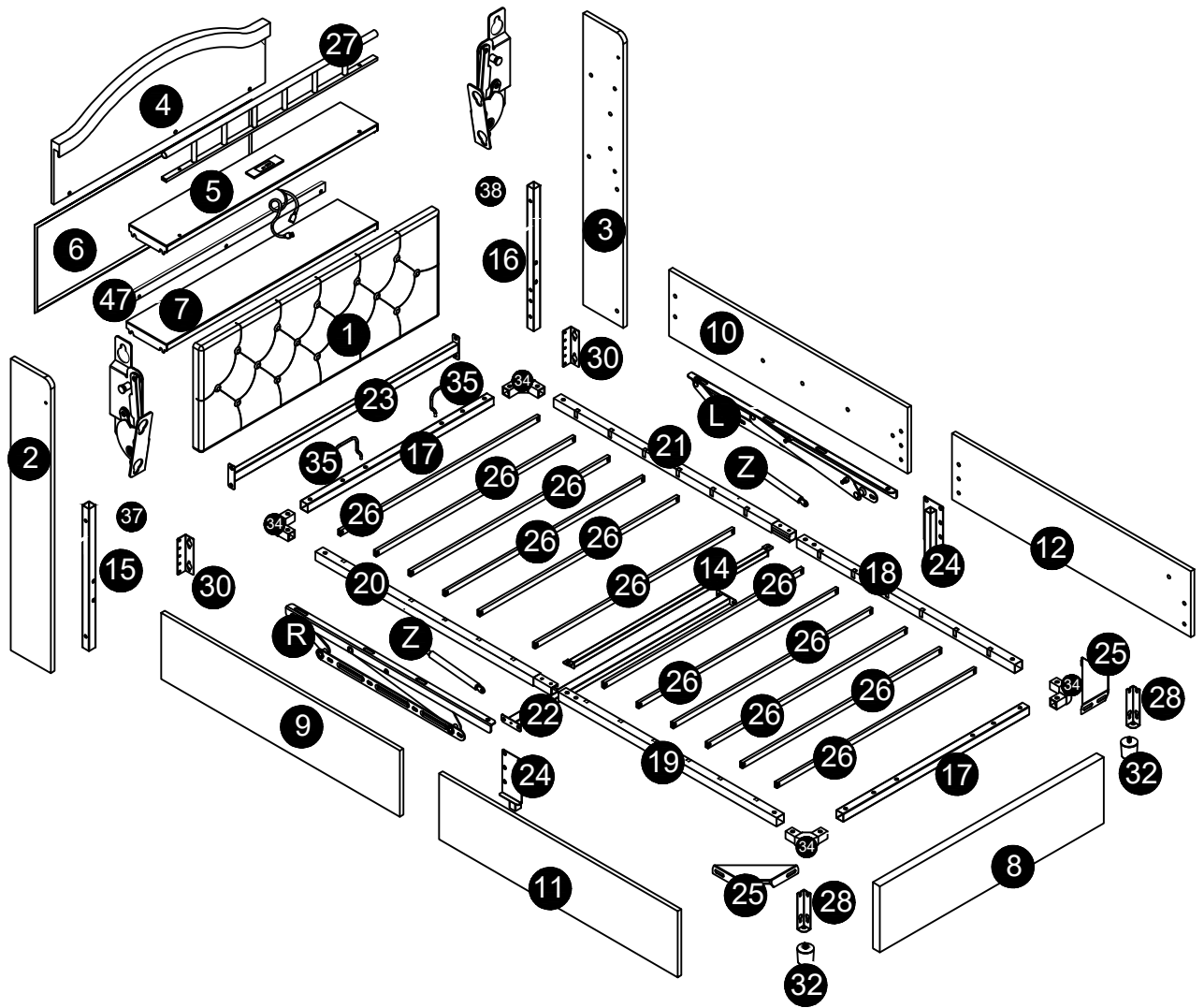

Assembly Instruction

1

I M8*45

X4

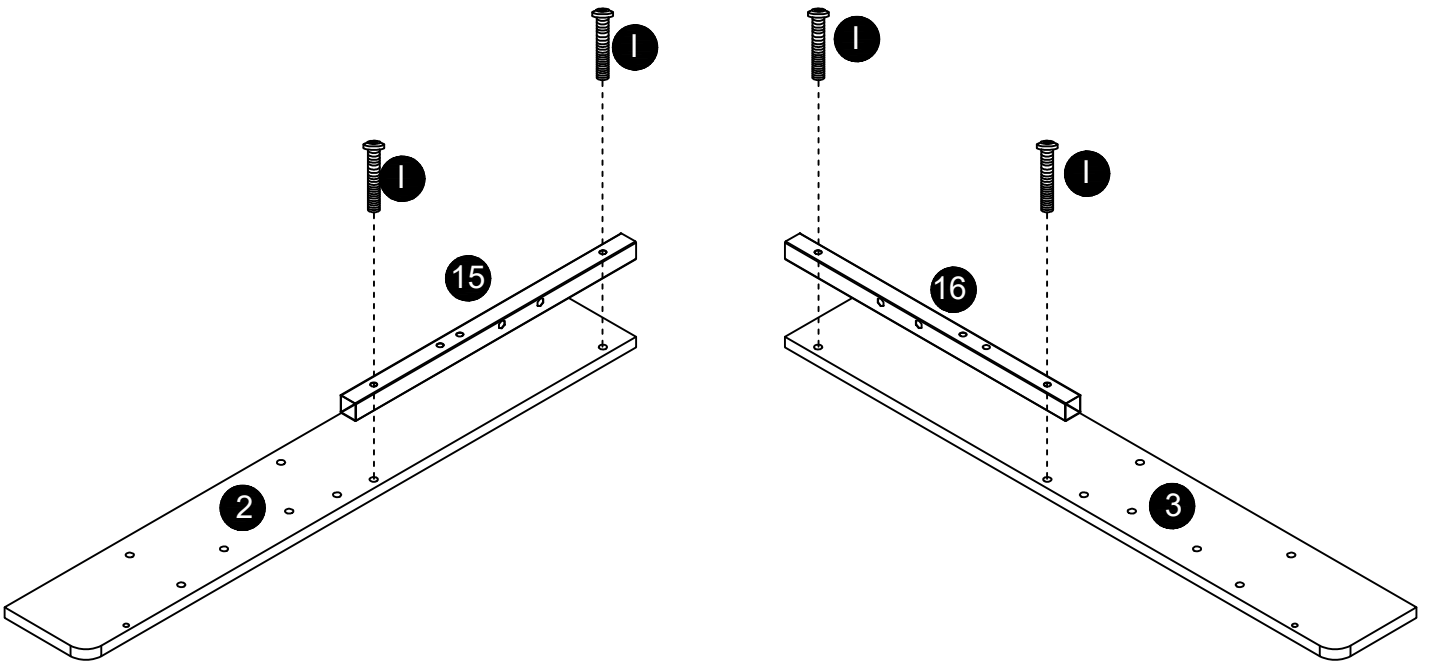

2

F M8*20

X8

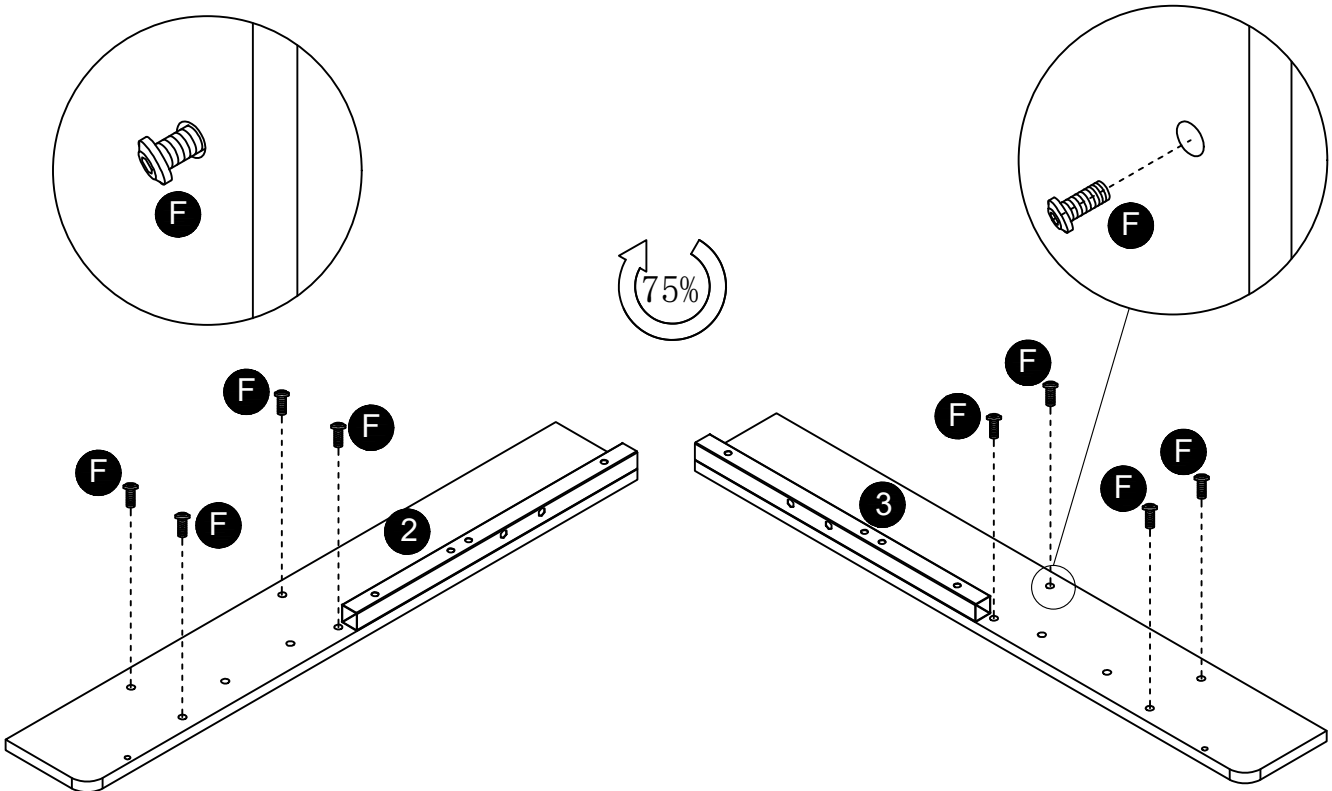

Assembly Instruction

3

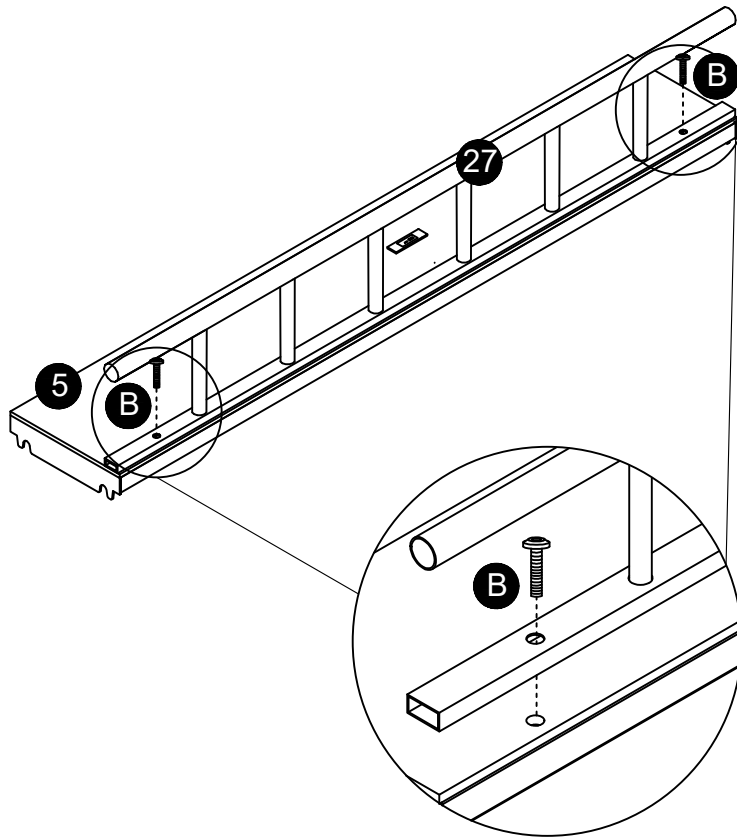

B M6*25(white)

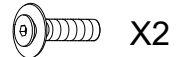

X2

4

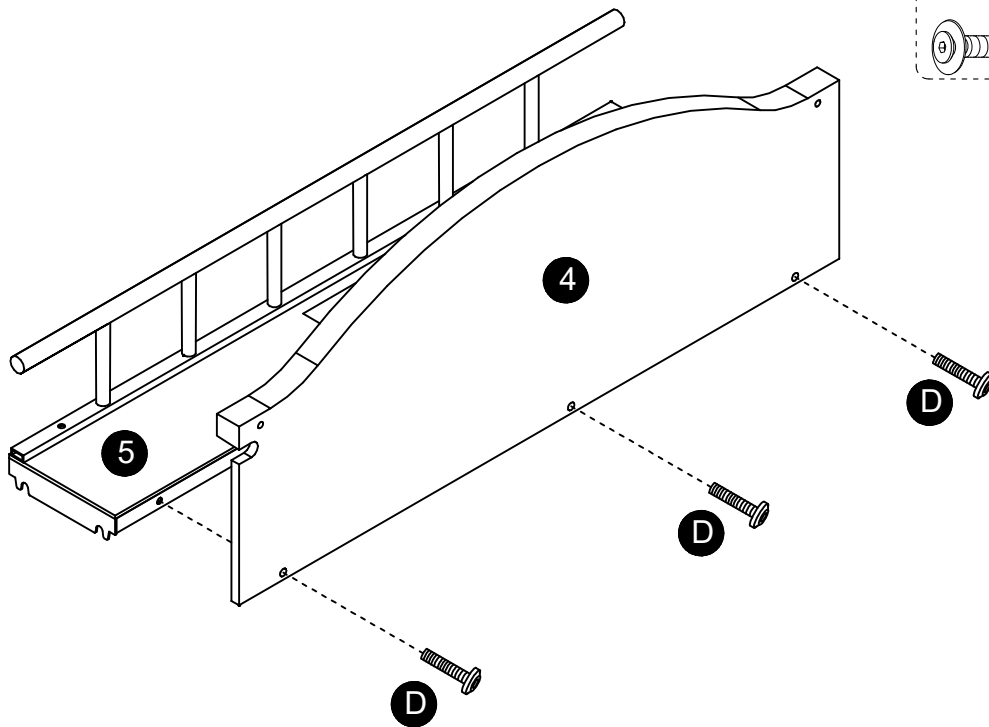

D M6*25



X3

Assembly Instruction

5

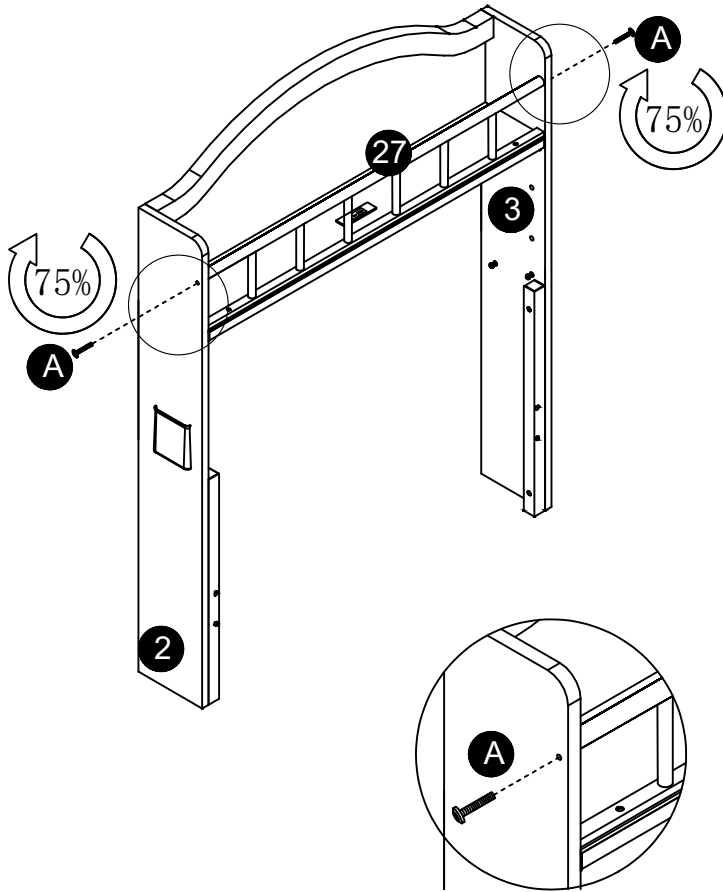

A M6*35(white)
X2

6

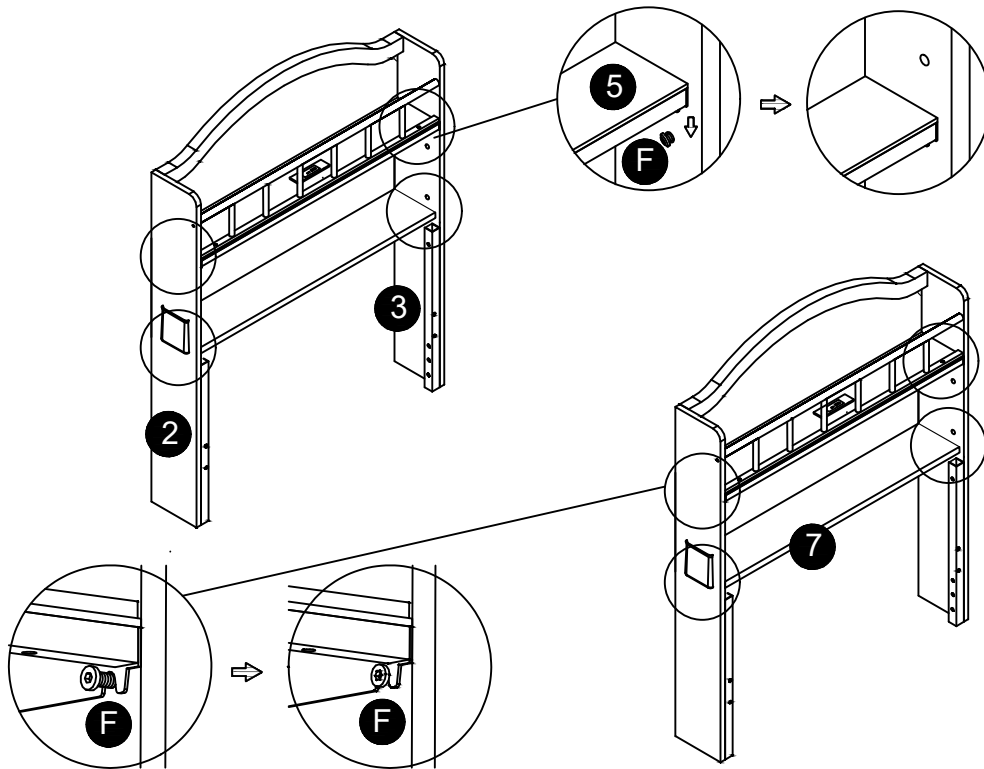

F is assembled in step 2

Assembly Instruction

7

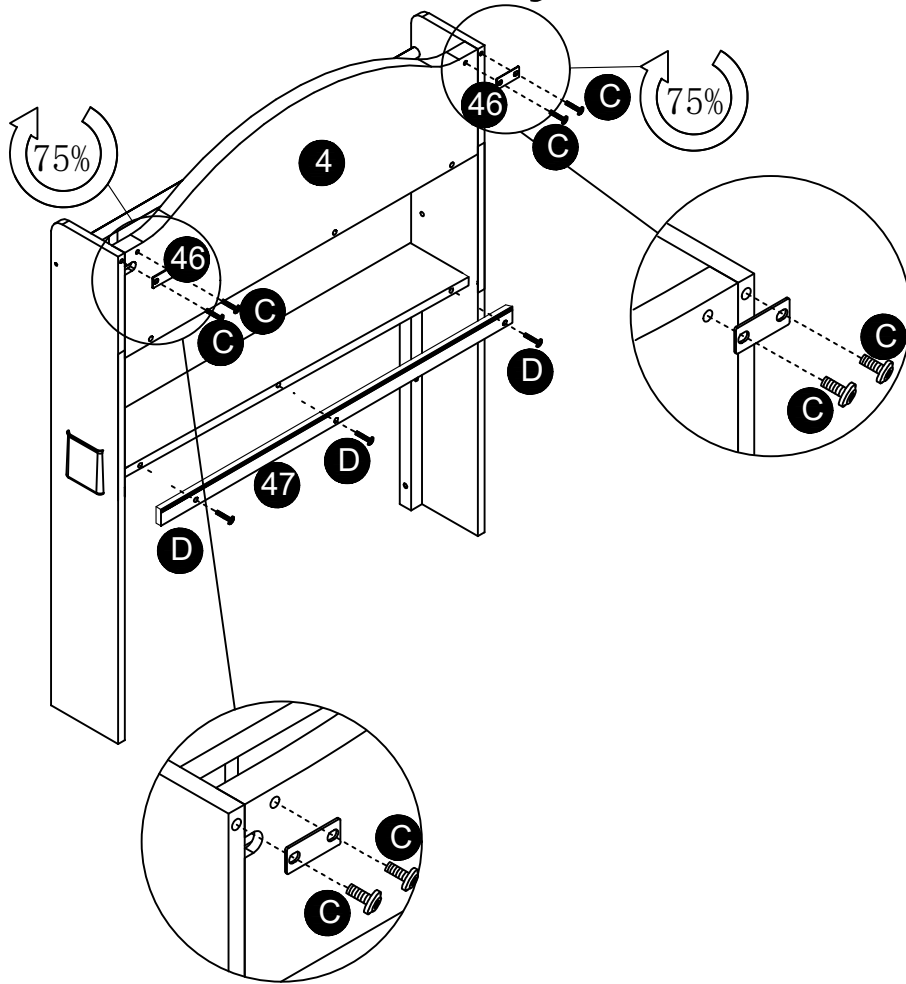

C M6*15



X4

D M6*25

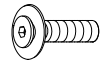

X3

8

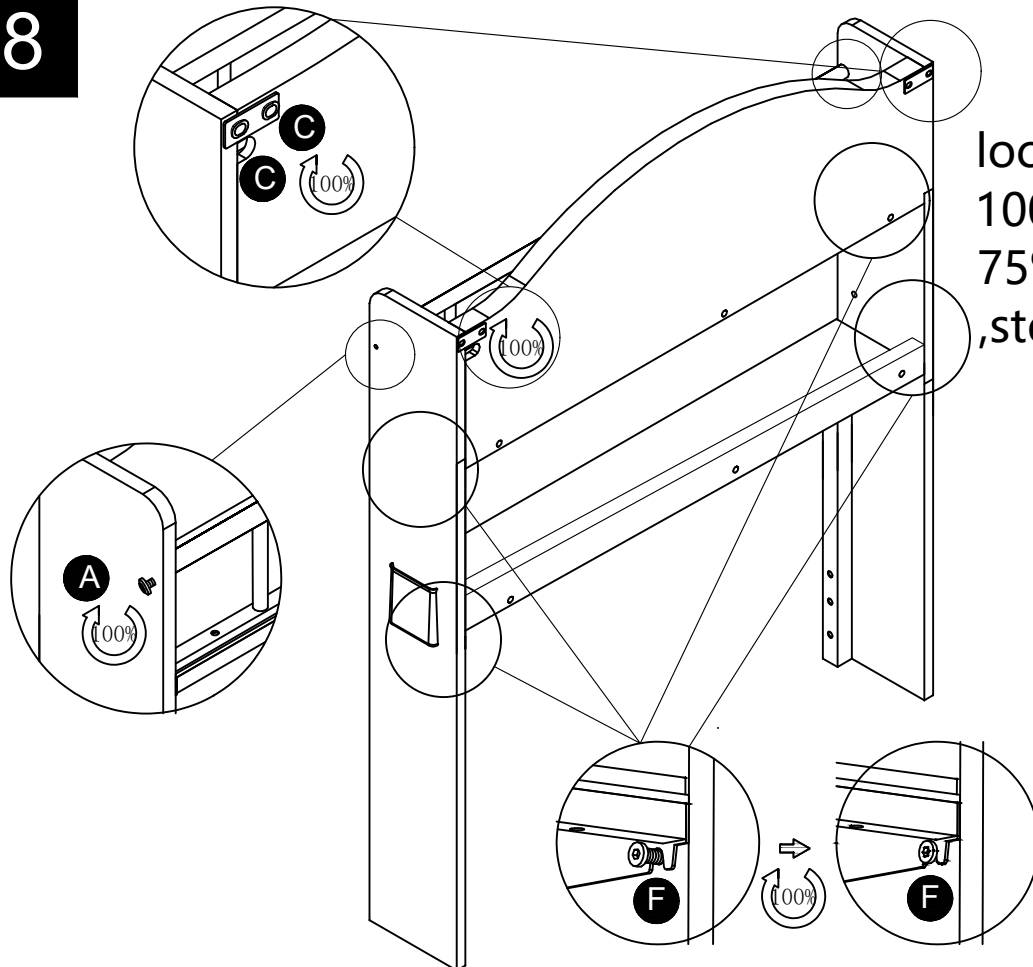

locking screws
100% that locked
75% in the step5
,step6,step 7

Assembly Instruction

9

C M6*15

 X4

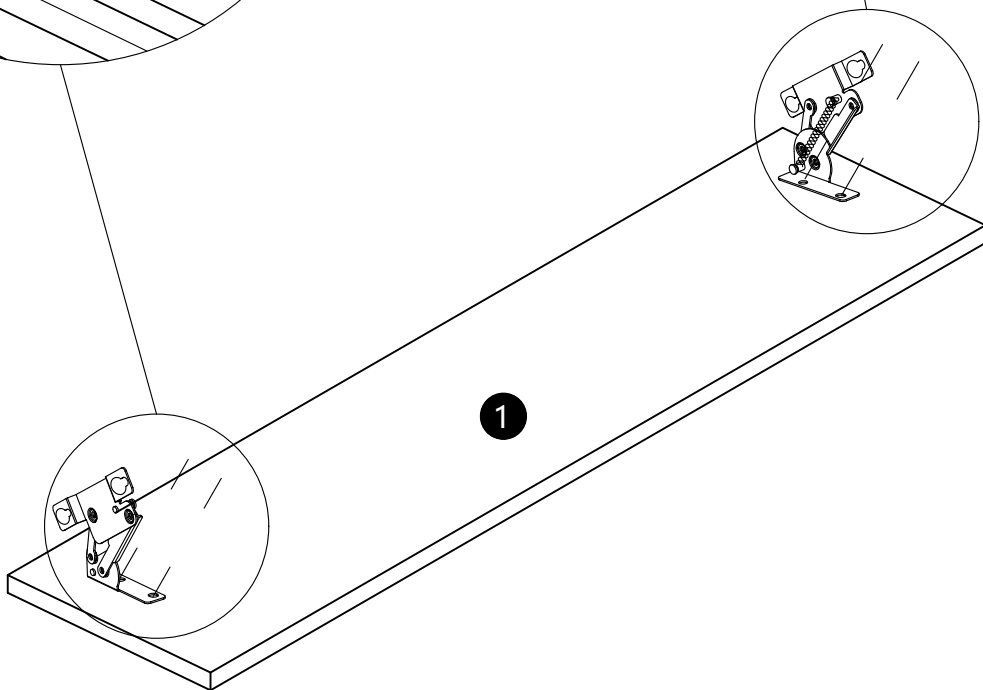
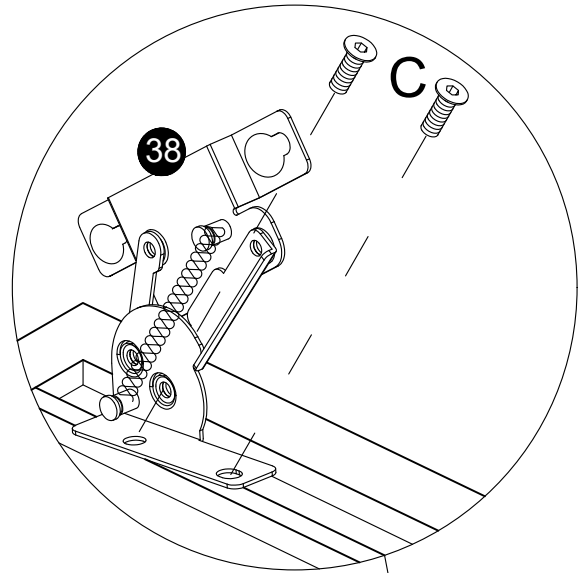
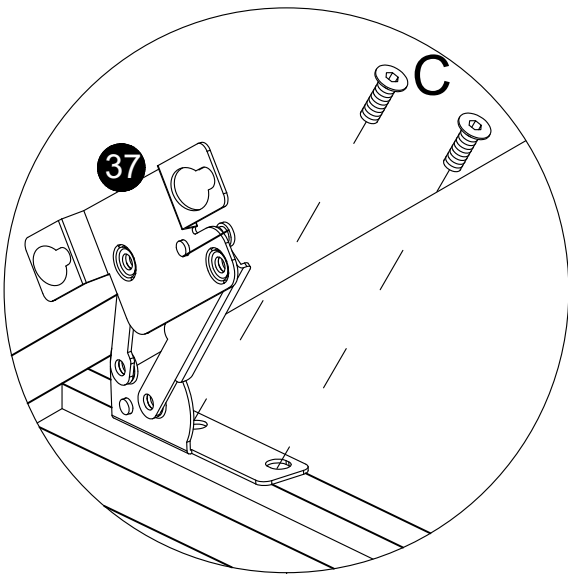

Assembly Instruction

10

E M8*15

X4

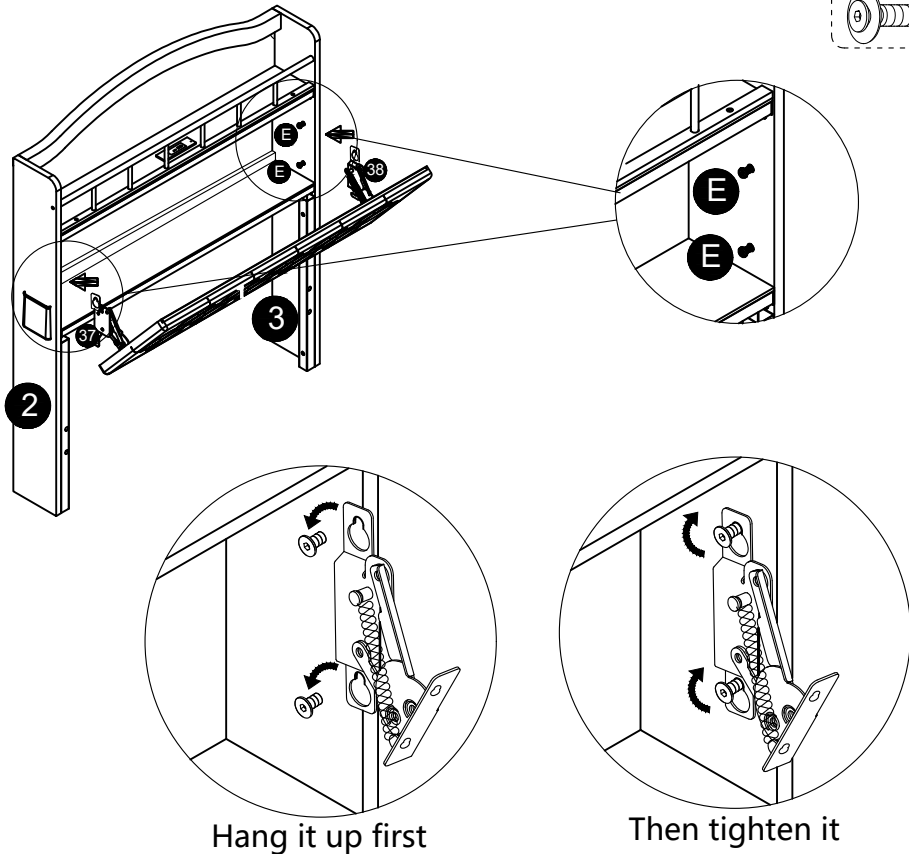

11

F M8*20

X4

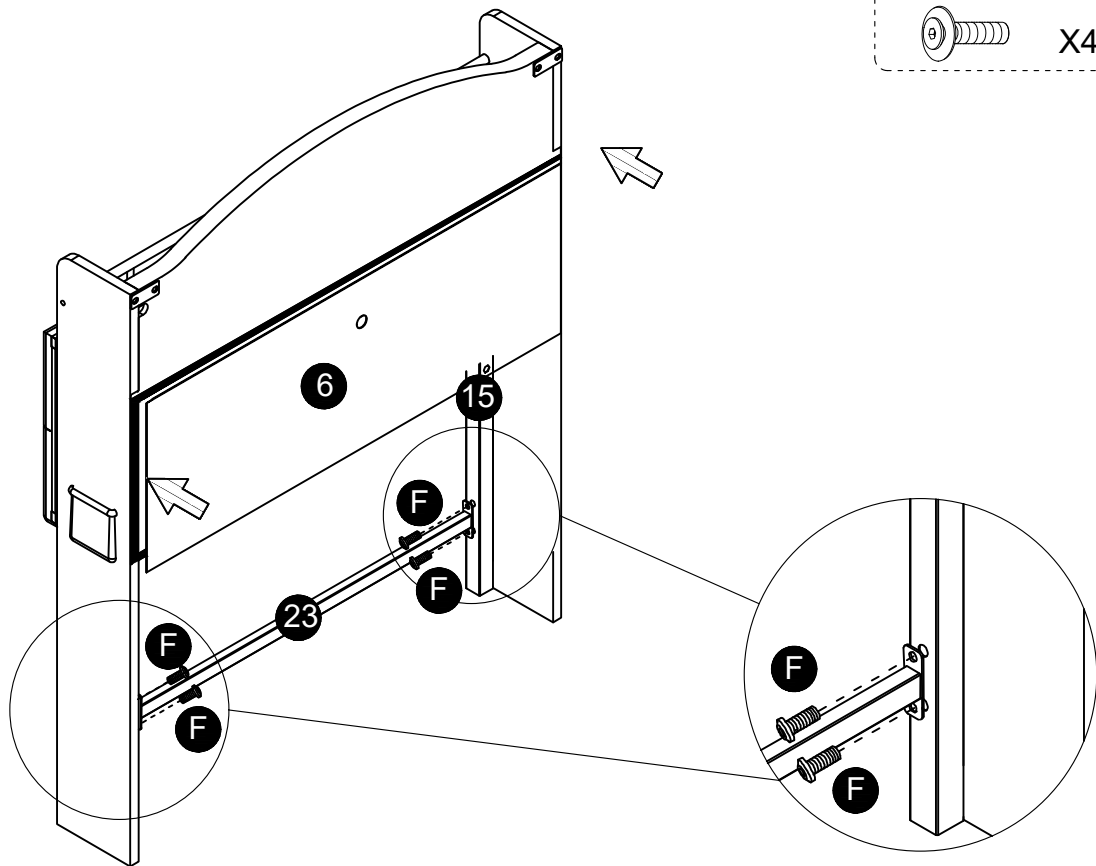

Assembly Instruction

12

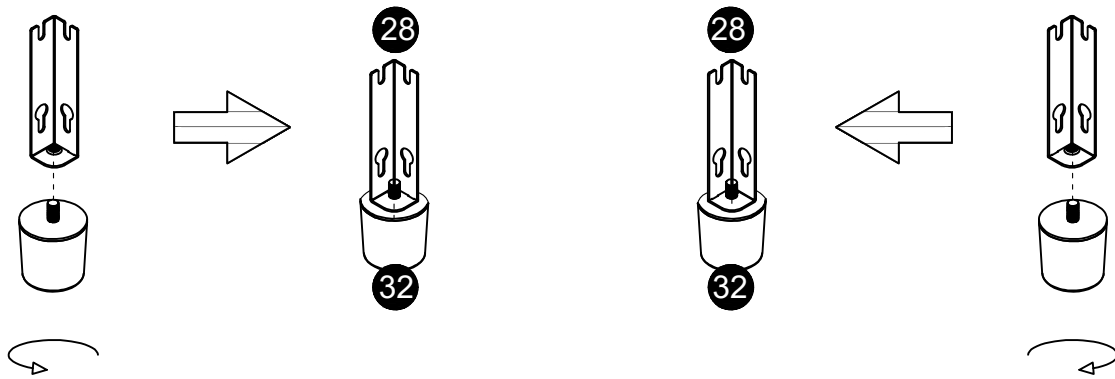

13

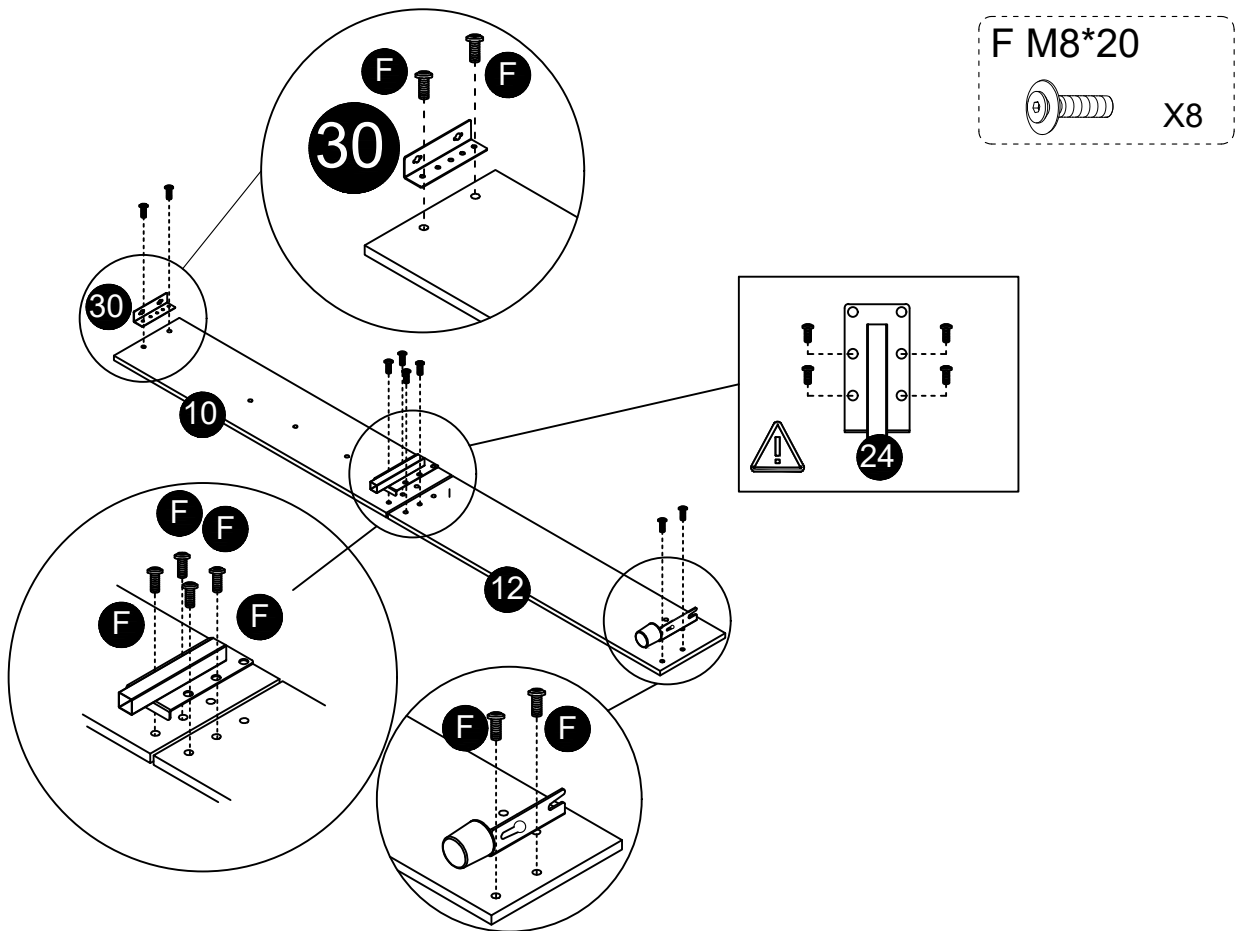

Assembly Instruction

14

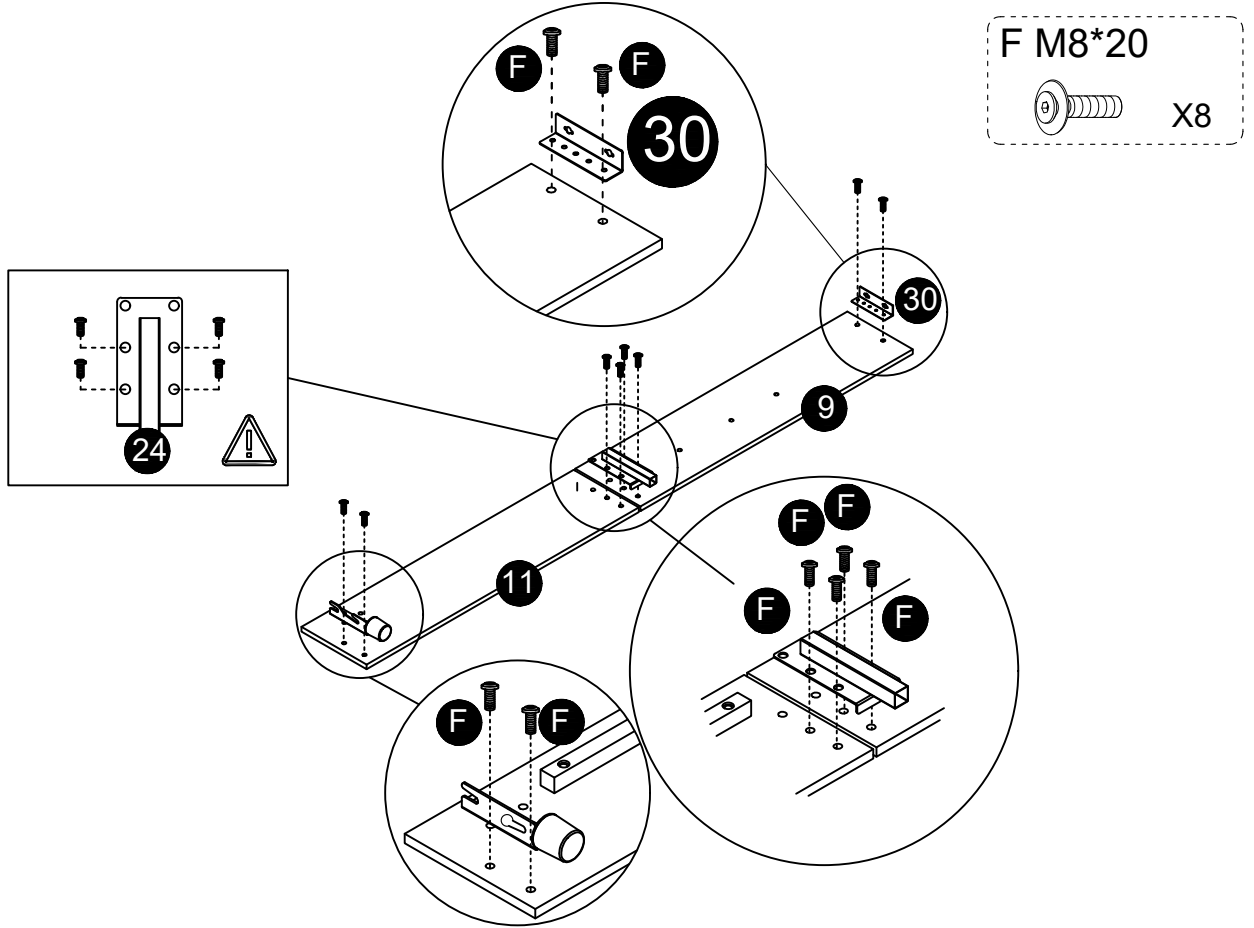

15

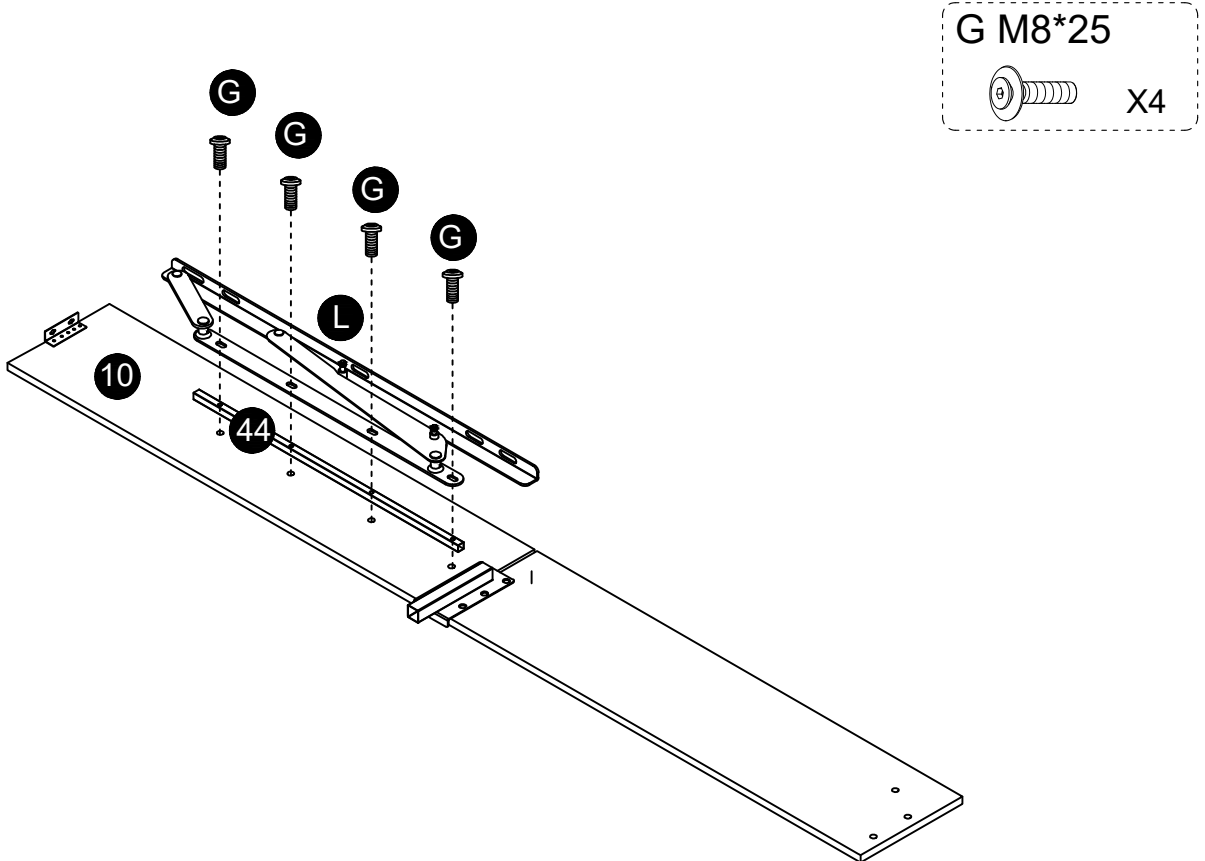

Assembly Instruction

16

G M8*25
 X4

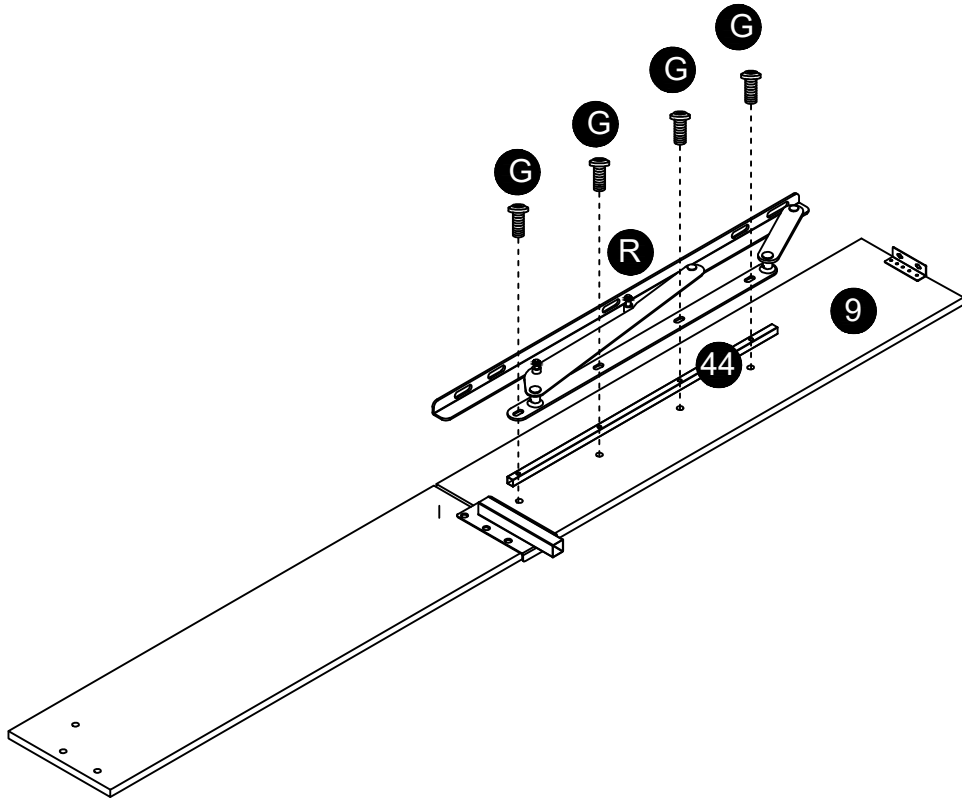

17

F M8*20
 X4

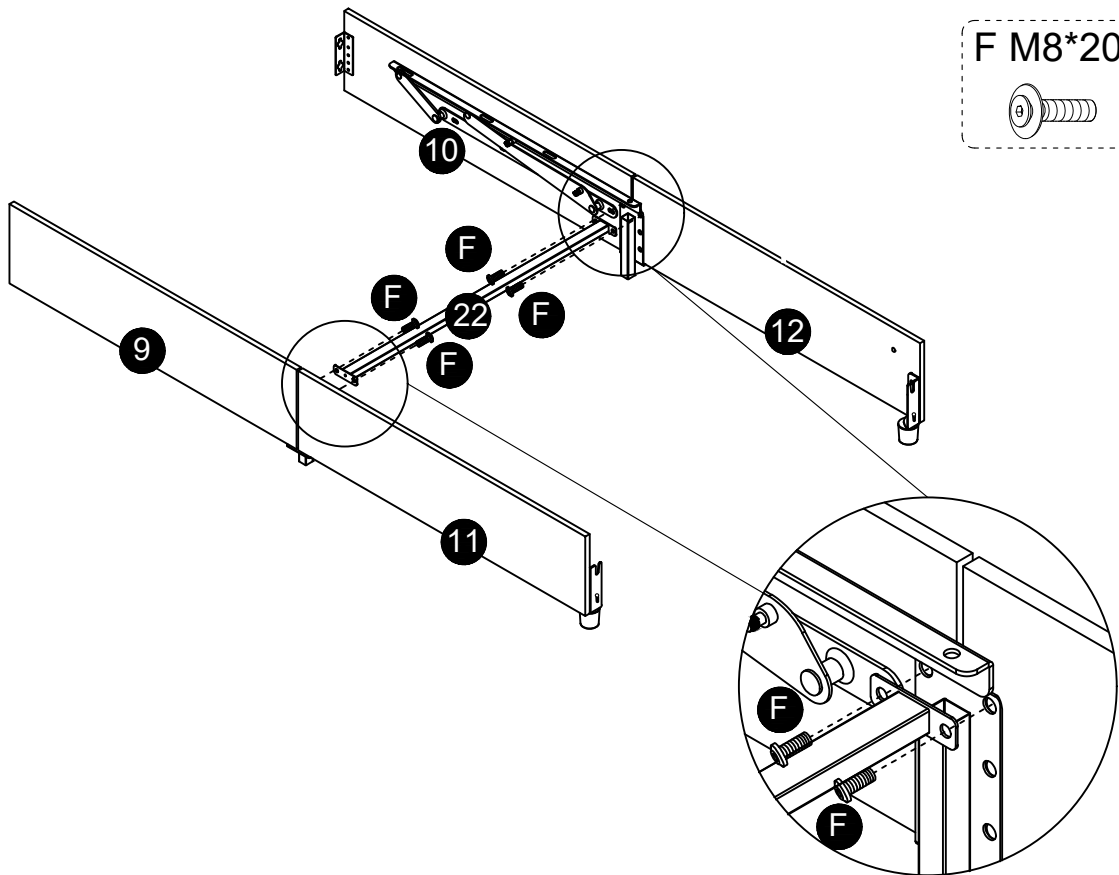

Assembly Instruction

18

G M8*25

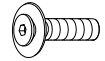

X4

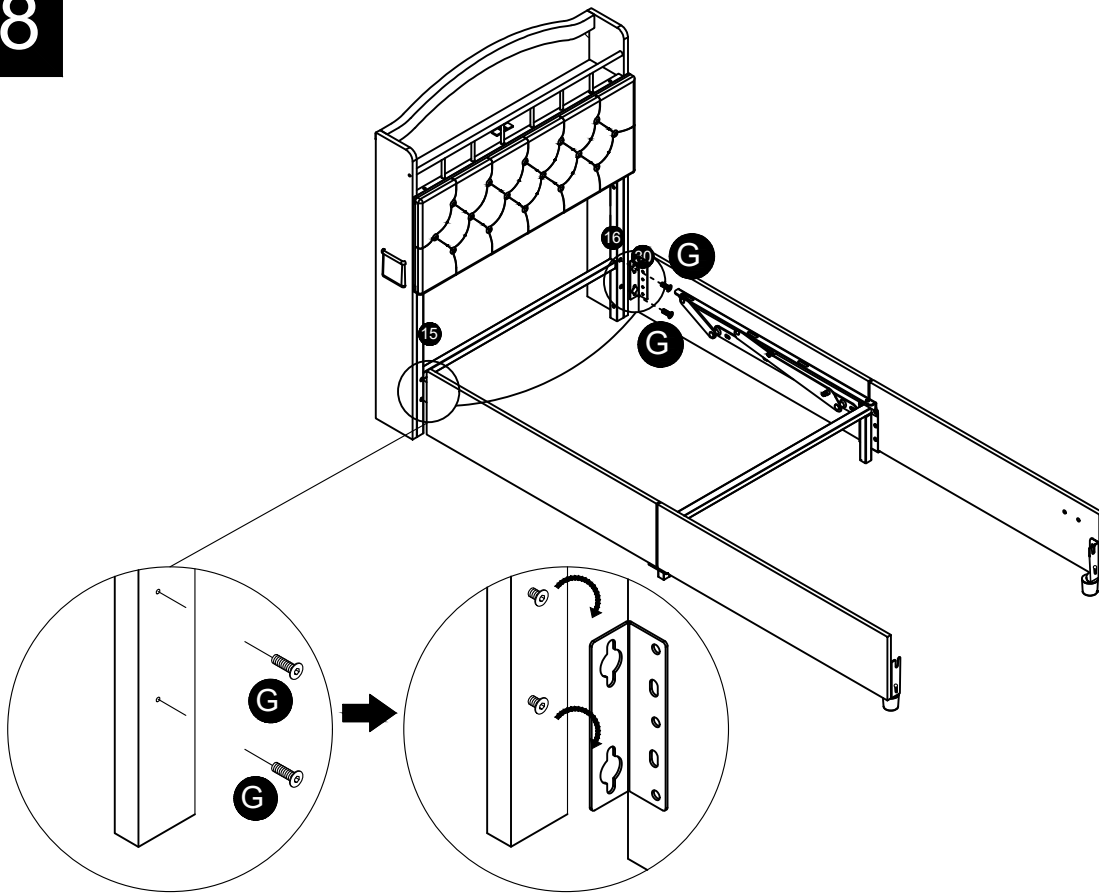

19

F M8*20

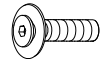

X4

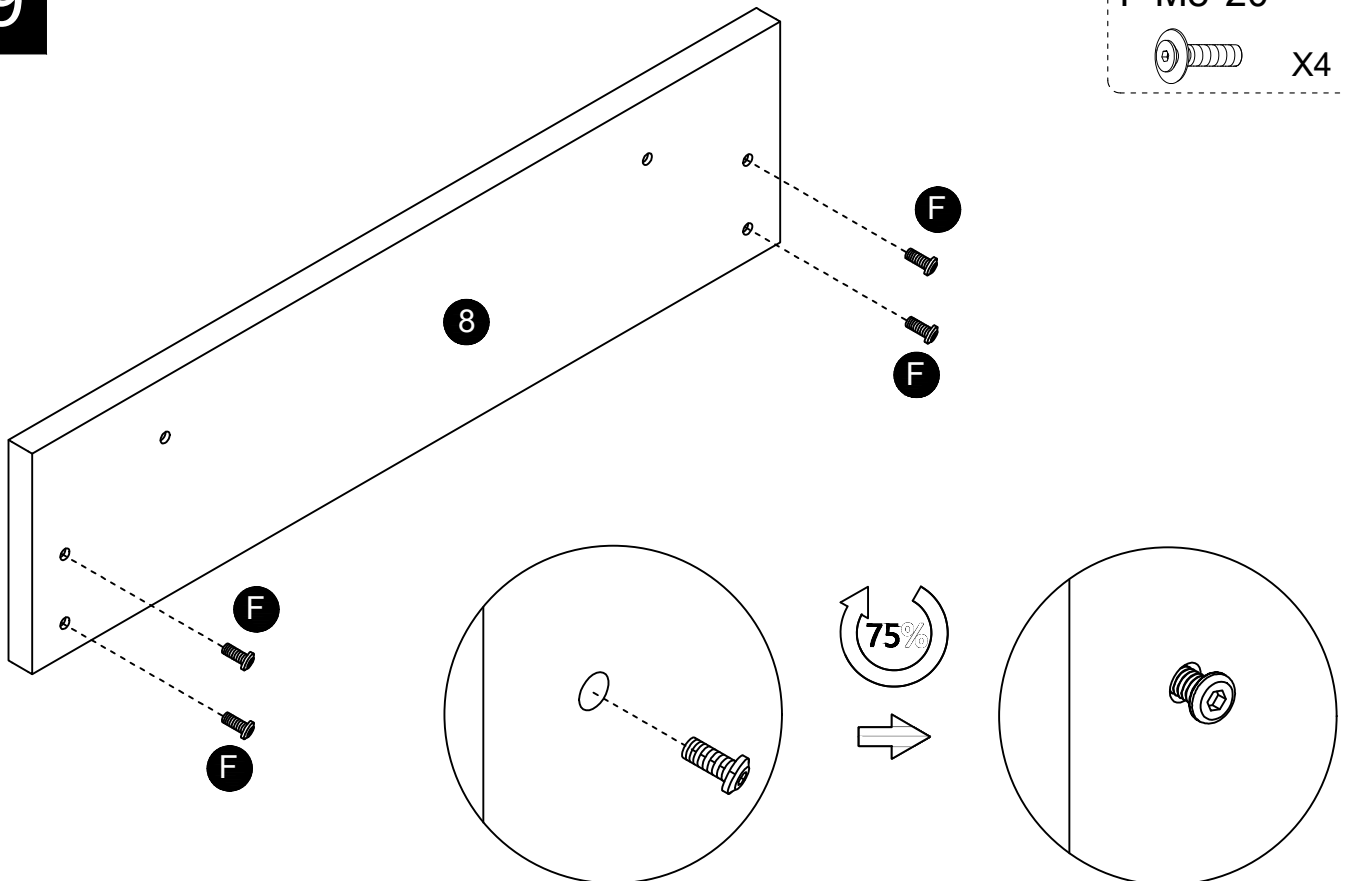

Assembly Instruction

20

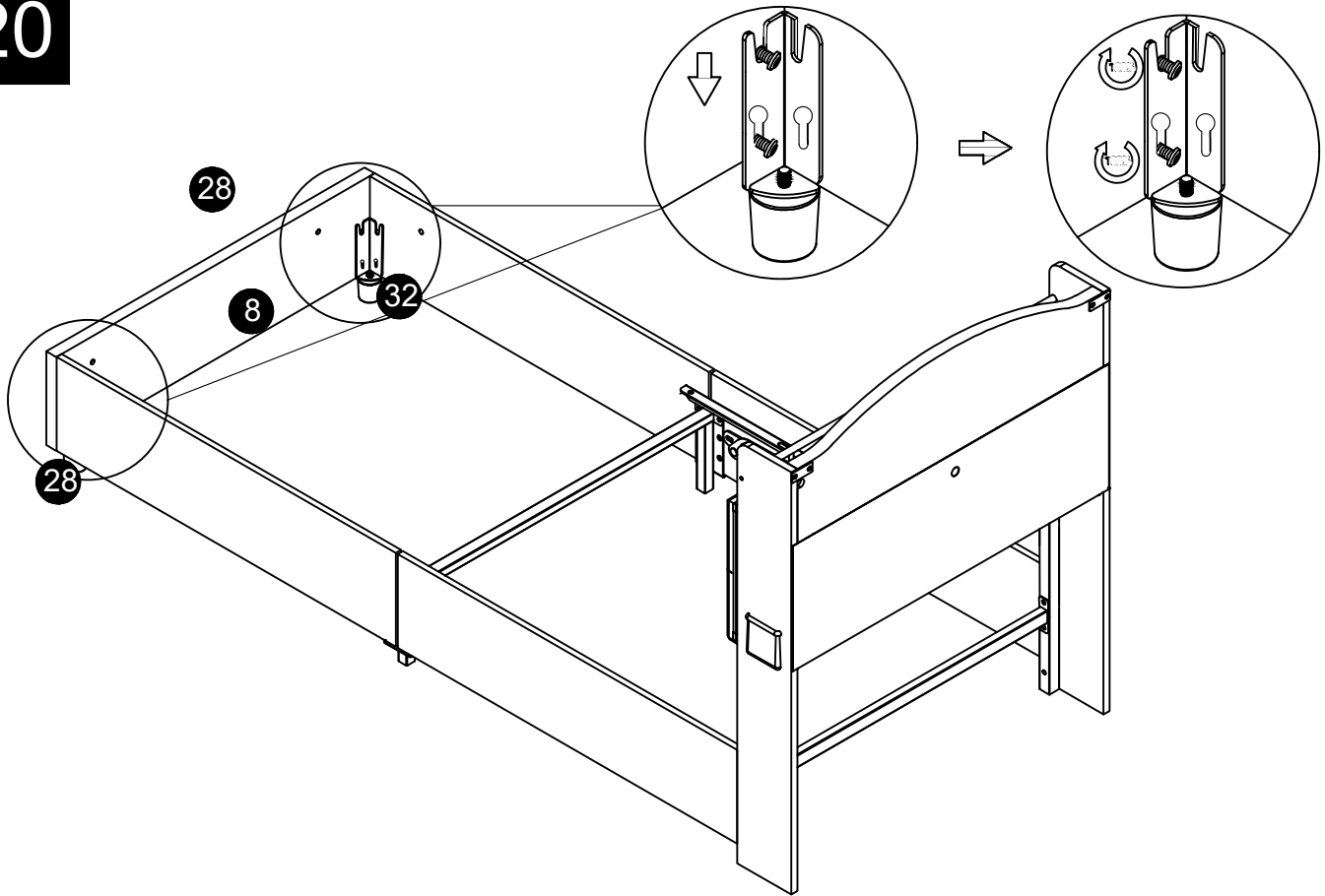

21

C M6*15
X4

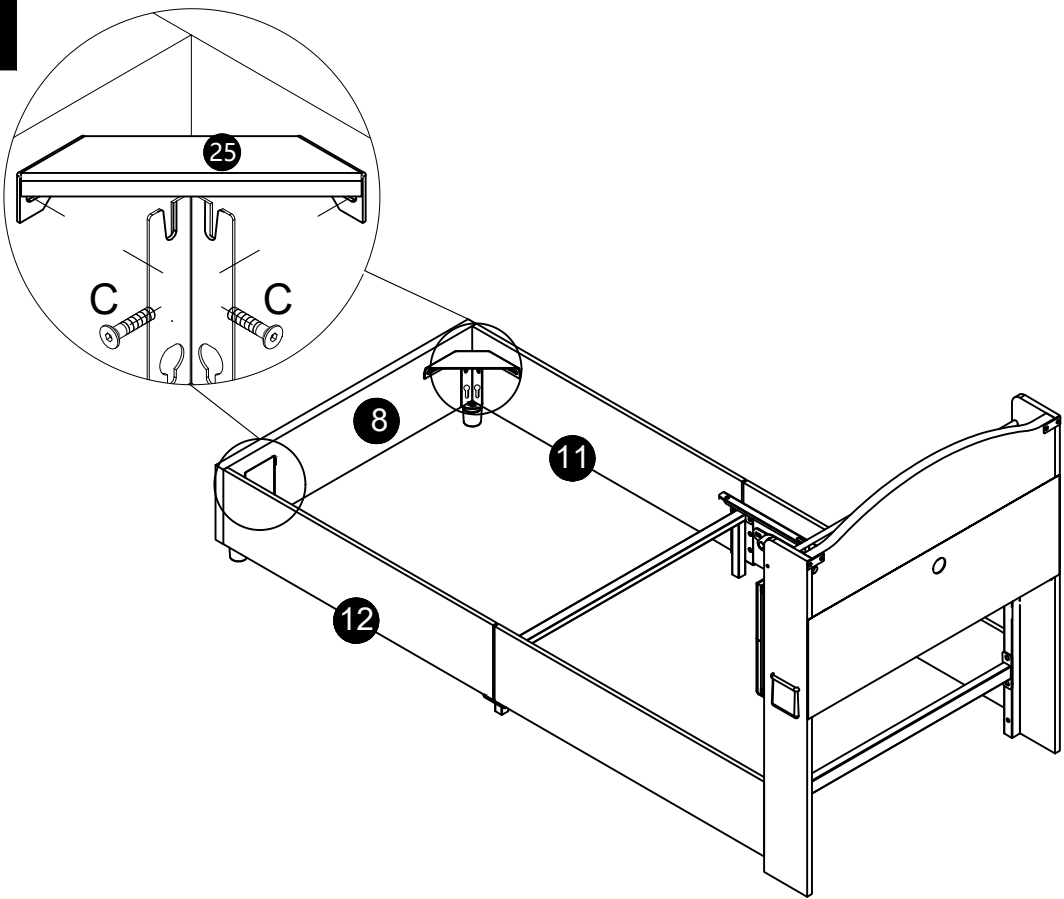

Assembly Instruction

22

connect two parts first, then lock the screws

E M8*15



X2

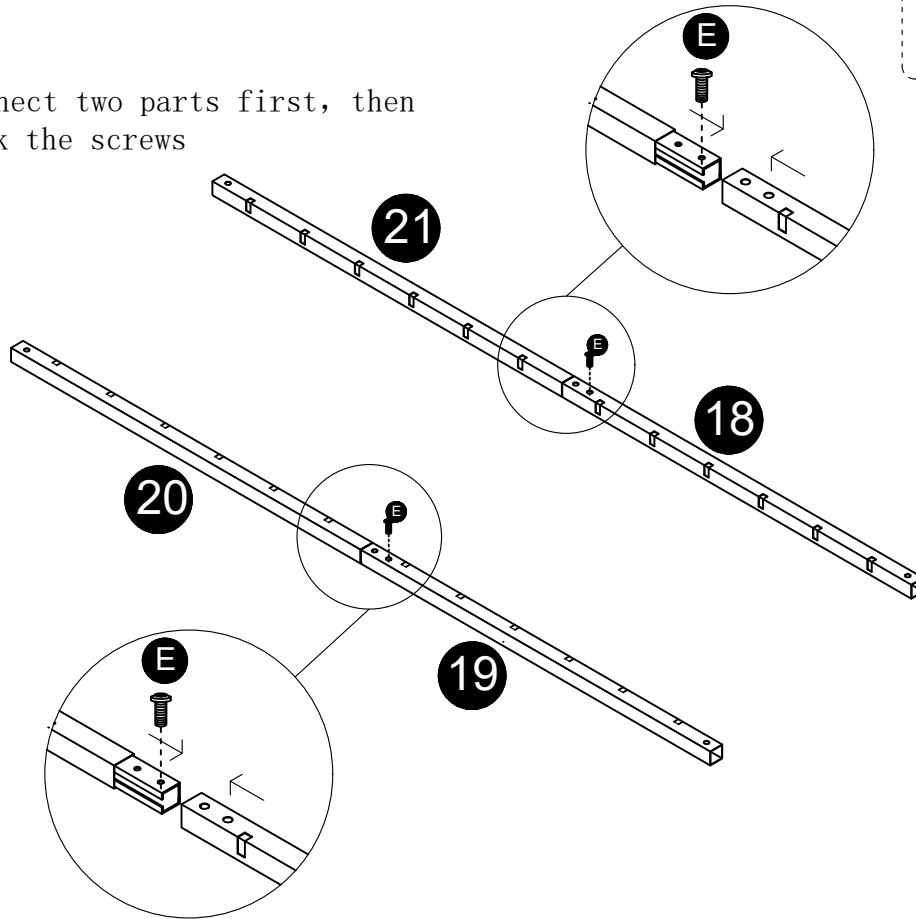

23

E M8*15

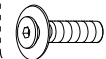

X8

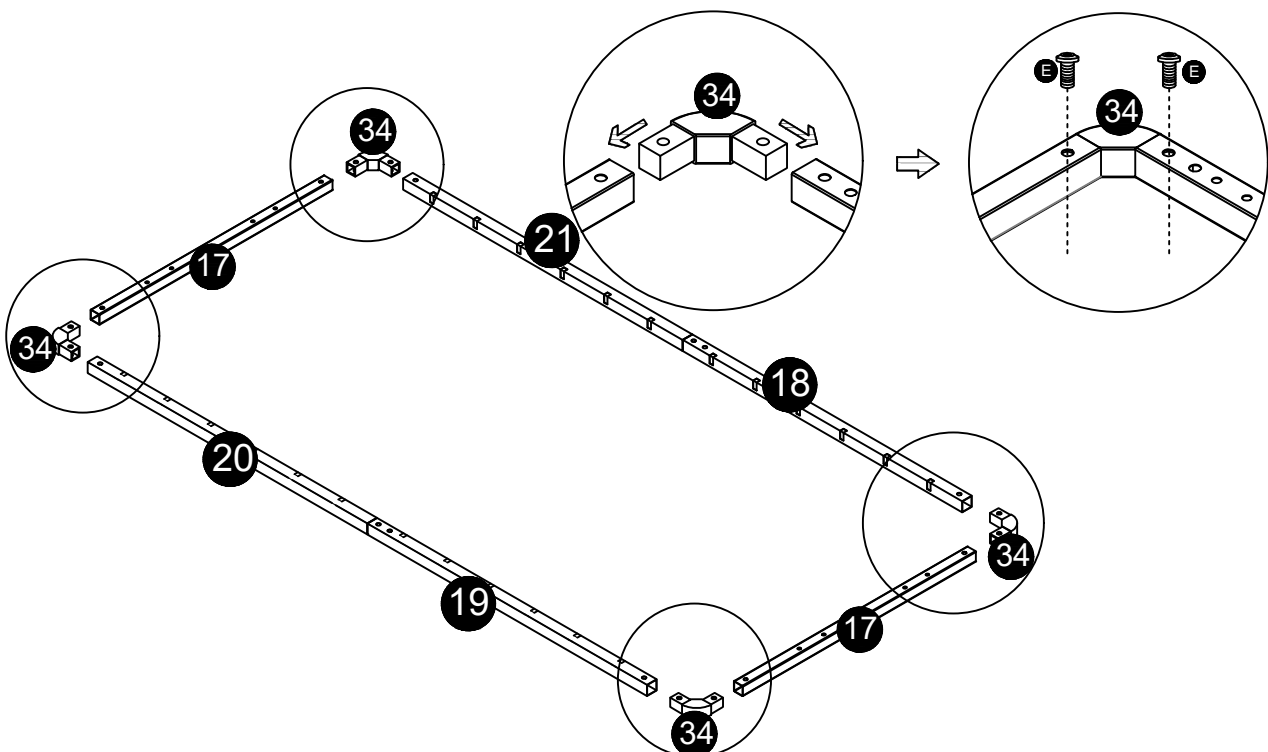

Assembly Instruction

24

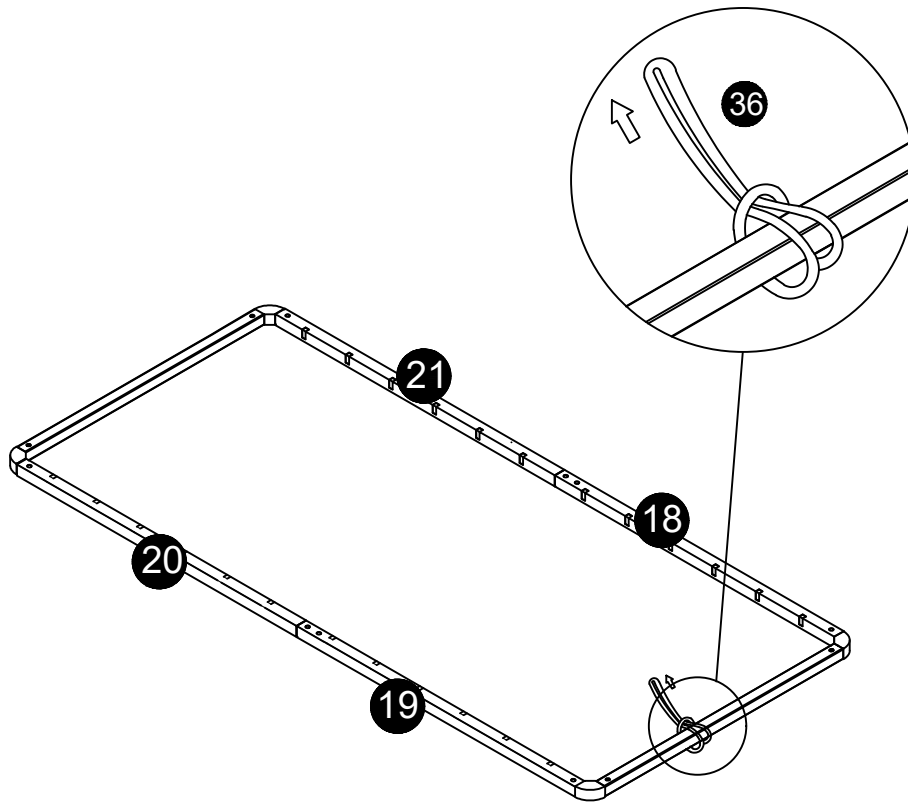

25

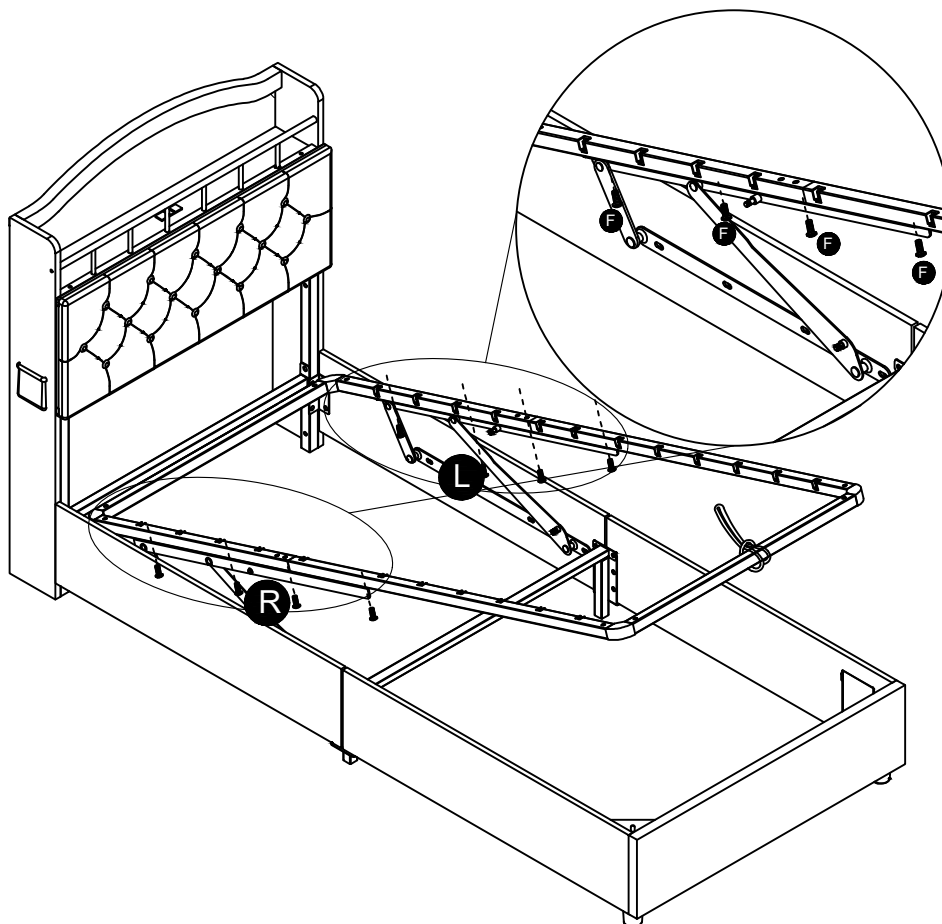

F M8*20

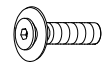

X8

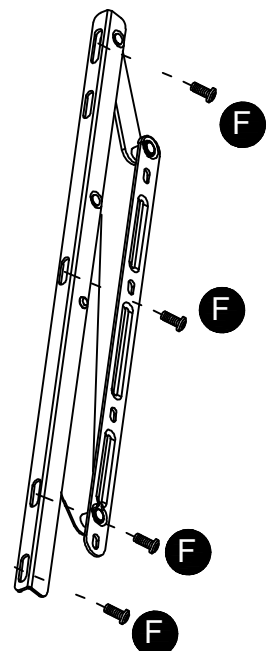

Assembly Instruction

26

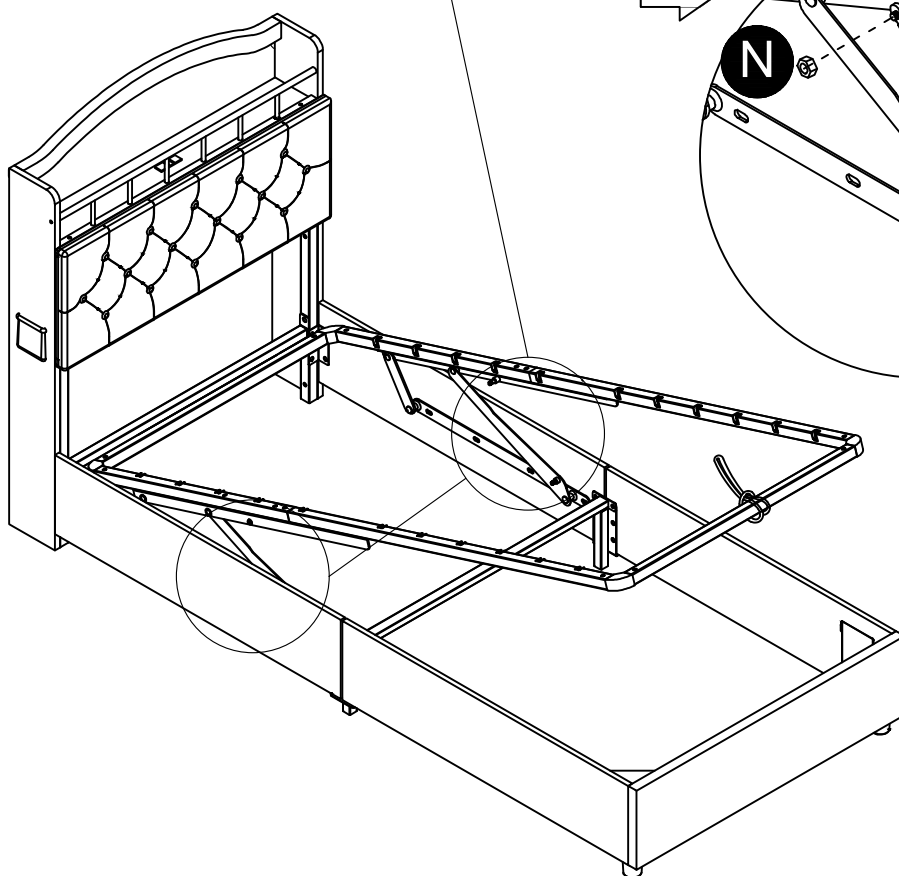
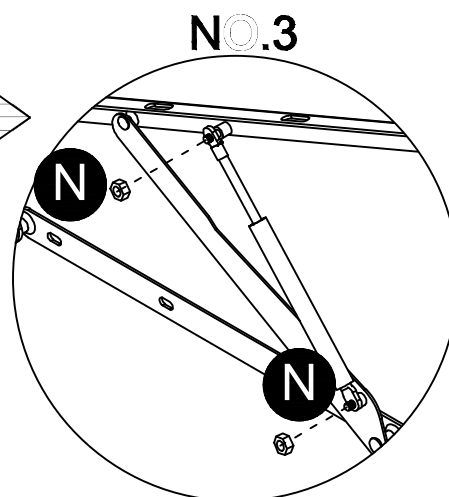
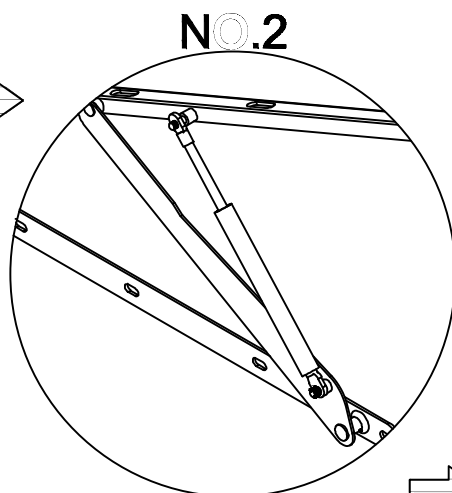
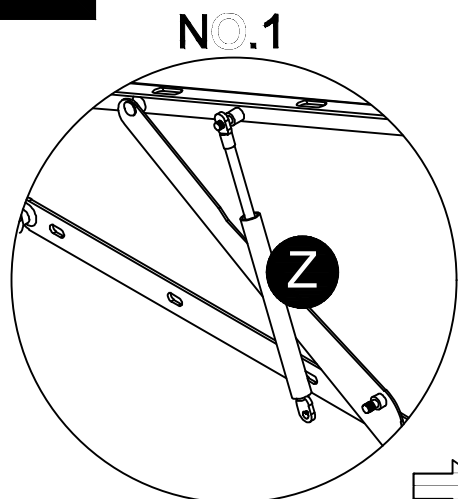
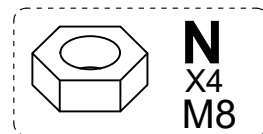

Assembly Instruction

27

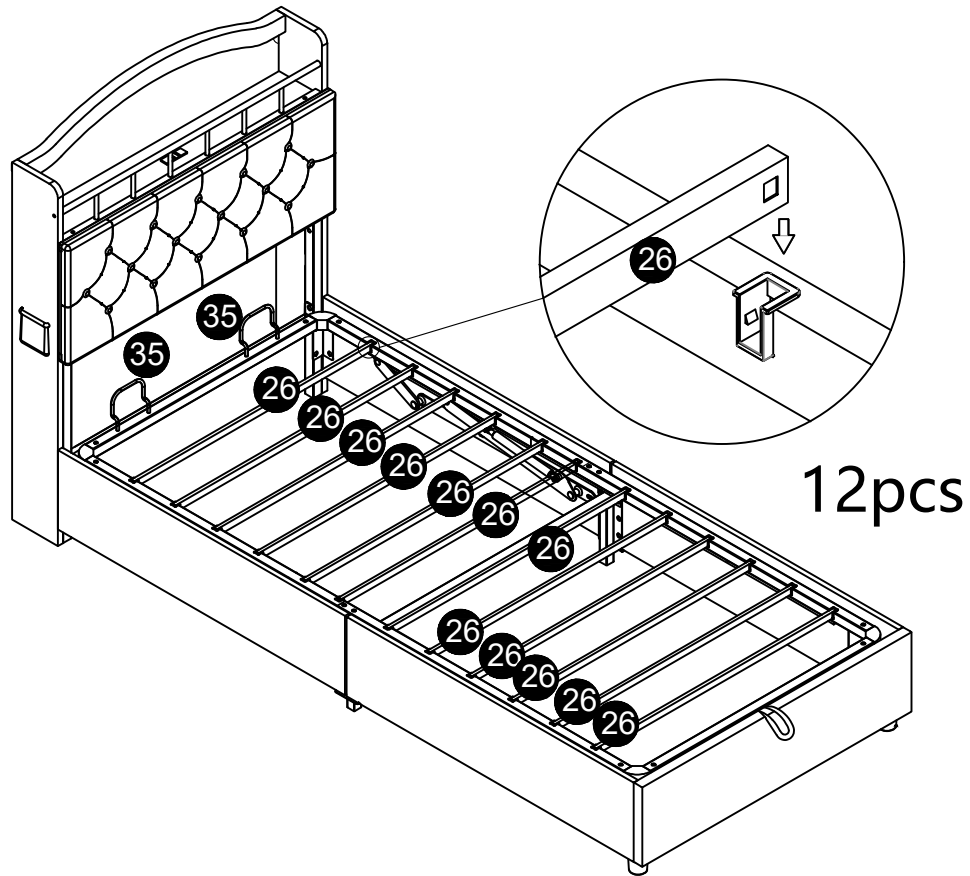

28

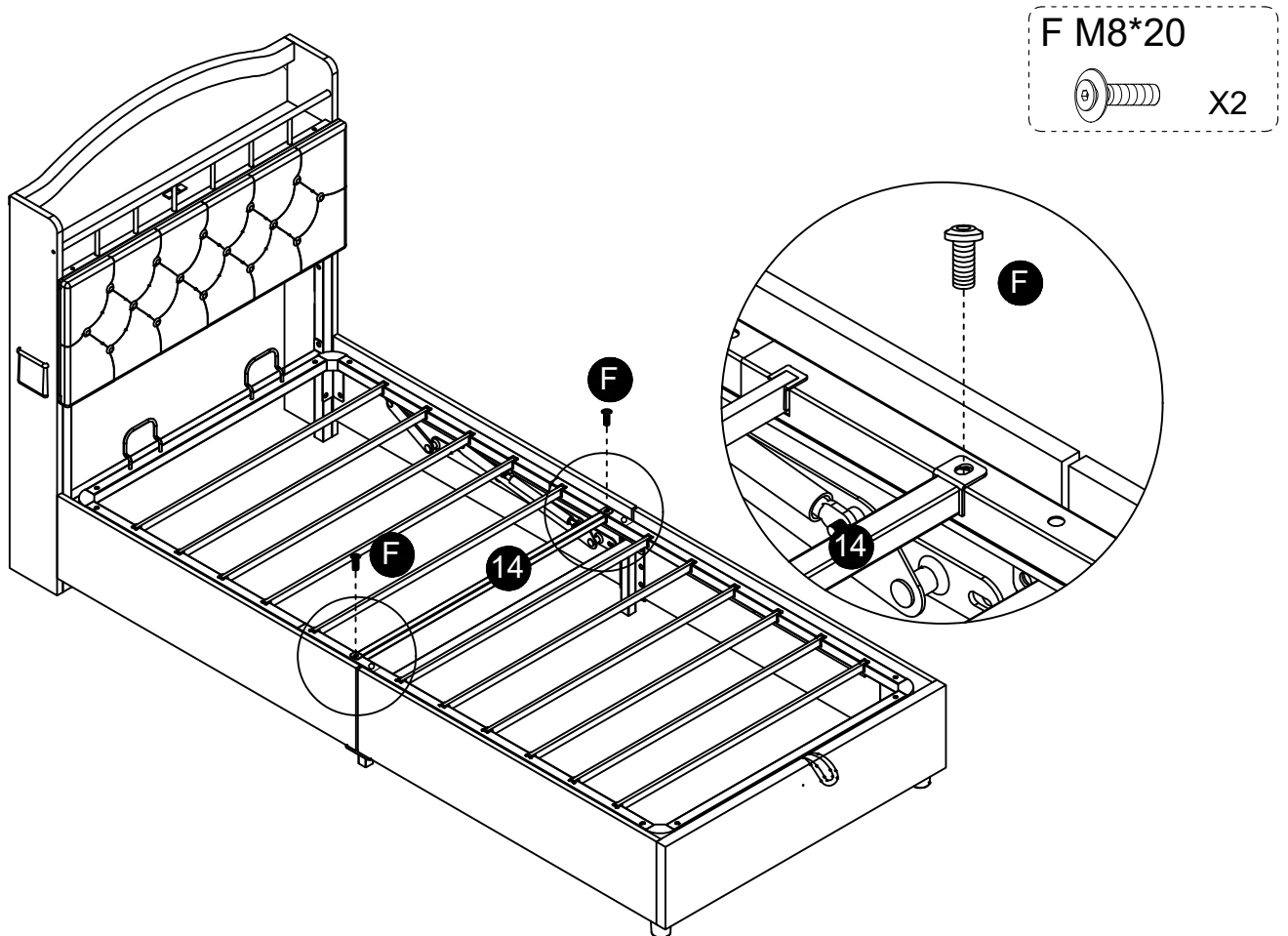

Assembly Instruction

29

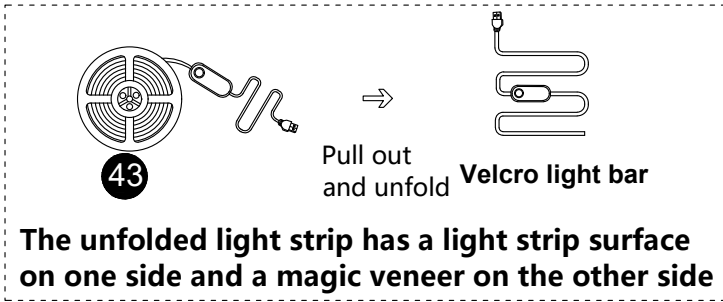

threading the light strip From the back to the front

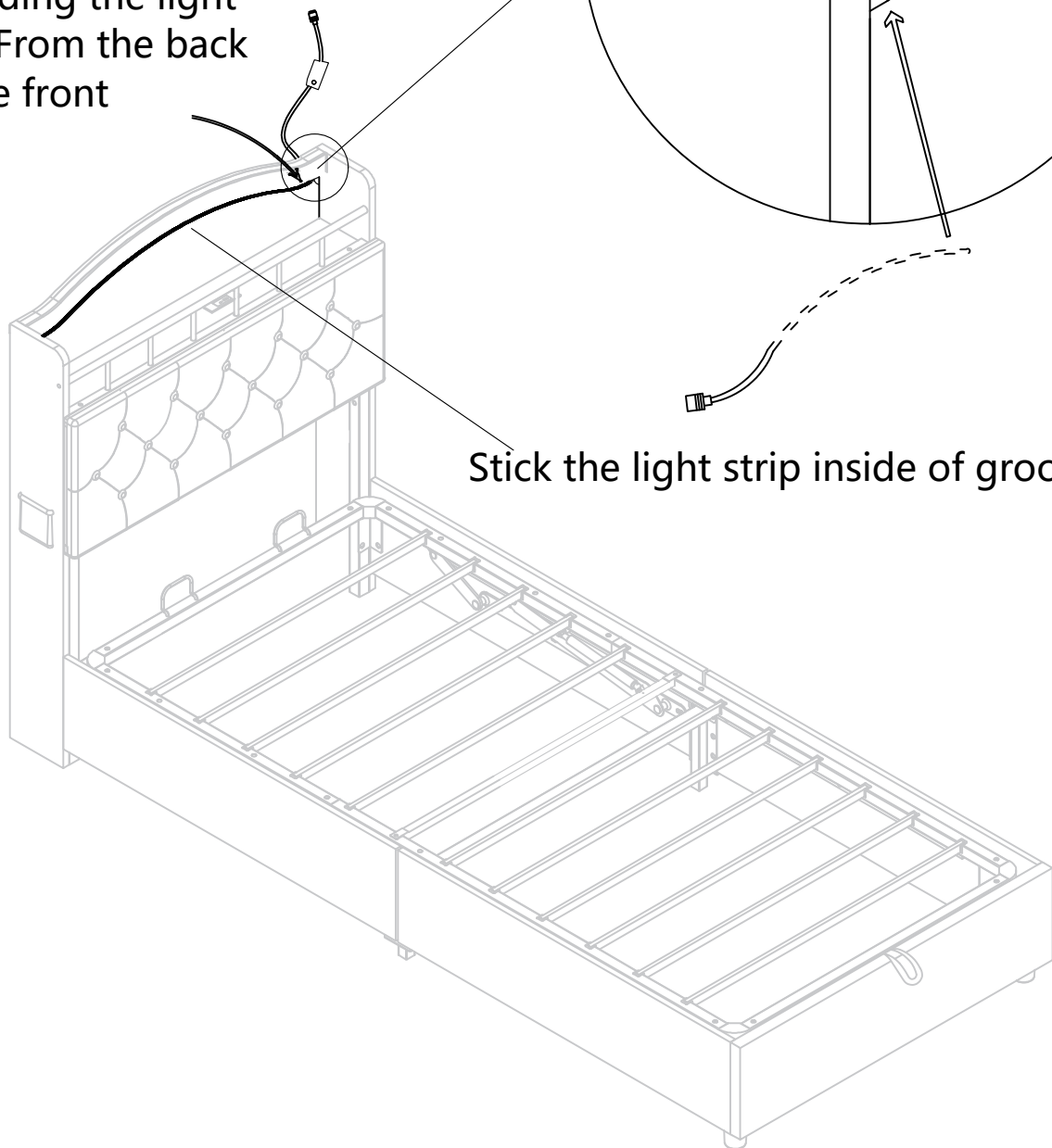

Assembly Instruction

30

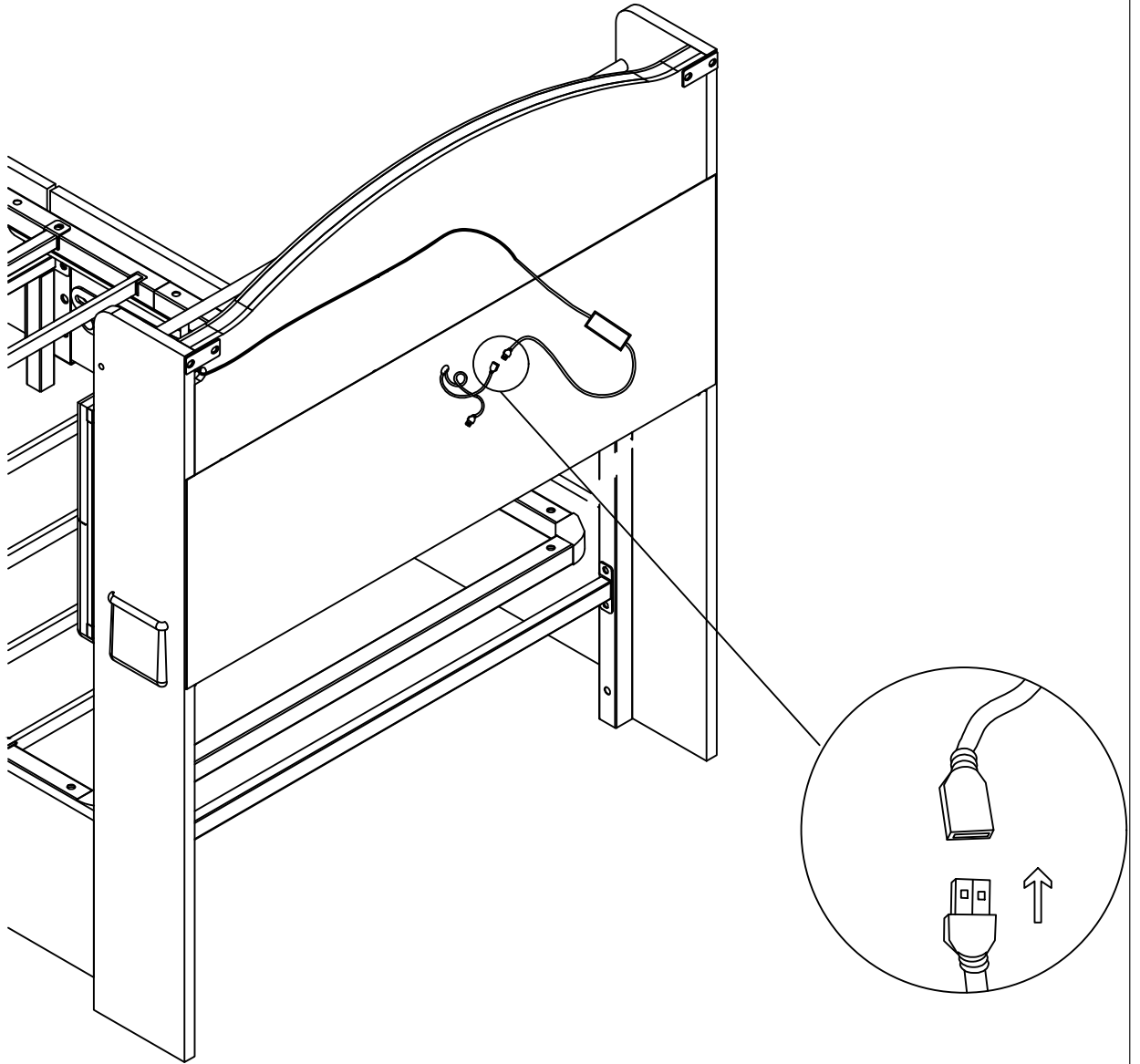

Attestation of Compliance



Attestation No. : LCSA08094161E

Approval Holder : Shenzhen Pinchengxin Technology Co., Ltd

Address : 3rd floor, 8 building Yuanling industrial zon, No. 39 Yuanlingcun road, Shiyan street, Bao'an district, Shenzhen

Manufacturer : Shenzhen Pinchengxin Technology Co., Ltd

Address : 3rd floor, 8 building Yuanling industrial zon, No. 39 Yuanlingcun road, Shiyan street, Bao'an district, Shenzhen

Brand Name : N/A

Product : 5050 RGB LED Strip Lights with Bluetooth App Controller

Type/Model Name : 5050 RGB

H/S Version : HW: 1.0
SW: 1.0

Attestation of the technical design of the radio equipment according to the following essential requirements set out in article 3 of the RED 2014/53/EU:

Article 3.1a): Health and Safety	Conform
Article 3.1b): Electromagnetic Compatibility	Conform
Article 3.2: Effective Use of the Radio Spectrum	Conform
CE-marking	

Marking Example (Class 1)



This attestation is issued in accordance with the Directive 2014/53/EU of the European Parliament and of the Council of 16 April 2014 on the harmonisation of the laws of the Member States relating to the making available on the market of radio equipment.

September 18, 2024

Date of issue



Manager

Shenzhen LCS Compliance Testing Laboratory Ltd.
Room 101, 201, Building A and Room 301, Building C, Juji Industrial Park, Yabianxueziwei, Shajing Street,
Bao'an District, Shenzhen, Guangdong, China
Tel: (86)0755-82591330 Fax: (86)0755-82591332
Http://www.lcs-cert.com Email: webmaster@lcs-cert.com



Shenzhen ZKT Technology Co., Ltd.
1/F, No. 101, Building B, No. 6, Tangwei Community Industrial Avenue,
Fuhai Street, Bao'an District, Shenzhen, China



Certificate of Compliance

Certificate Number: ZKT-2405094943C

Certificate's Holder : Shenzhen Pinchengxin Technology Co., Ltd
3rd Floor, 8th Building Yuanling Industrial Zone, No. 39
Yuanlingcun Road, Shiyan Street, Bao'an District,
Shenzhen

Manufacturer : Shenzhen Pinchengxin Technology Co., Ltd
3rd Floor, 8th Building Yuanling Industrial Zone, No. 39
Yuanlingcun Road, Shiyan Street, Bao'an District,
Shenzhen

Trade Mark : N/A

Product : 5050 RGB LED Strip Lights with Bluetooth App Controller
and 2.4G Remote

Model(s) : 5050 RGB LED Strip Lights

Test Standard : Art.3.1(a) Safety BS EN IEC 62368-1:2020+A11:2020

Art.3.1(a) Health BS EN IEC 62311:2020
BS EN 50665:2017

Art.3.1(b) EMC ETSI EN 301 489-1 V2.2.3 (2019-11)
ETSI EN 301 489-17 V3.2.4 (2020-09)

Art.3.2 Radio ETSI EN 300 328 V2.2.2 (2019-07)

This Attestation of Compliance is issued on a voluntary basis for electrical equipment below the voltage limits of Radio Equipment Directive (RED) SI 2017 No.1206. The essential requirements are fulfilled accordingly based on the technical specifications applicable at the time of issuance.



This Certificate of Conformity is based on single evaluation of the submitted sample(s) of the above mentioned product. It does not imply an assessment of the whole product and relevant Directives to be observed.

Shenzhen Pinchengxin Technology Co., Ltd

Federal Communications Commission
Authorization and Evaluation Division
Equipment Authorization Branch
7435 Oakland Mills Road
Columbia, MD 21046

9/2/2024

U.S. Agent Designation

Shenzhen Pinchengxin Technology Co., Ltd acknowledges their consent for the following contact located in the United States to act as their agent for service of process for the equipment for which authorization is sought (FCC ID: ~~2BKKLPCX~~-977):

Name and company of U.S. agent: FCC US Agent, LLC
Physical U.S. address of agent: 3722 Illinois Avenue, Saint Charles, IL, 60174, USA
FRN of U.S. agent: 0033402884
Email address of U.S. agent: Support@FCCUSAgent.com

FCC US Agent, LLC acknowledges their obligation to accept service of process on behalf of Shenzhen Pinchengxin Technology Co., Ltd.

Shenzhen Pinchengxin Technology Co., Ltd with the FRN 0035866896 accepts its obligation to maintain an agent for service of process in the United States for no less than one year after either the grantee has permanently terminated all marketing and importation of the applicable equipment within the U.S., or the conclusion of any Commission-related administrative or judicial proceeding involving the equipment, whichever is later.

By signing this form, we confirm the above and that we are aware of the application requirements listed under § 2.911(d)(7).

The information provided in this letter is based on the referenced rule parts of Title 47 of the CFR as well as KDB 986446 D01.

An expiration date for this letter does not exist. In case the U.S. agent changes, the grantee is obligated to notify the FCC within 30 days via the granting TCB.

Sincerely,

CHENG ZHANG

Signature
CHENG ZHANG
Manager
Shenzhen Pinchengxin Technology Co., Ltd

Tim
Payne

Digitally signed by Tim Payne
DN: cn=Tim Payne, o=FCC US Agent, LLC, email=Support@FCCUSAgent.com, c=US

Signature
Tim Payne
Manager
FCC US Agent, LLC