

Package Contents

<p>A Tray</p>  <p>3PCS</p>	<p>B Short Lower Stopper</p>  <p>4PCS</p>	<p>C Long Upper Stopper</p>  <p>4PCS</p>	<p>D Long Supporting Rod</p>  <p>4PCS</p> <p>E Short Supporting Rod</p>  <p>4PCS</p>
--	---	---	--

1

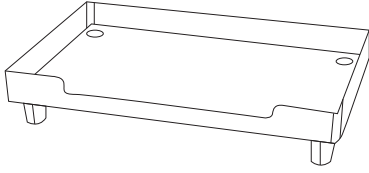
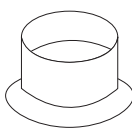
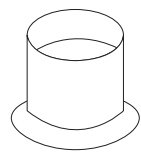
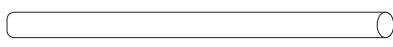
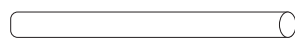
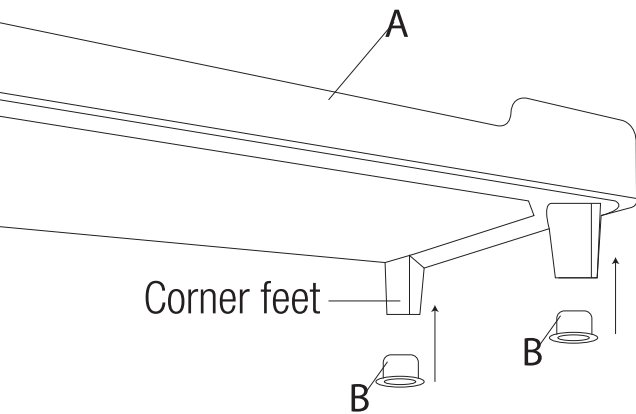

Corner feet

Step 1: Insert the short lower stoppers (B), into the bottoms of the four corner feet of one of the trays (A) as shown above.

2

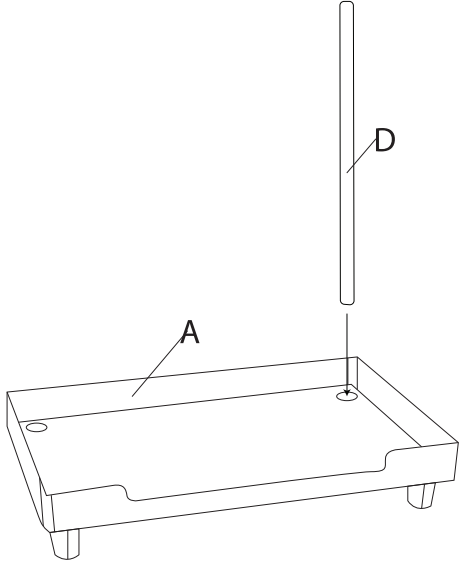

Step 2: Insert one long supporting rod (D) into the corner of the tray (A) as shown above. Repeat with the rest of the long supporting rods (D).

3

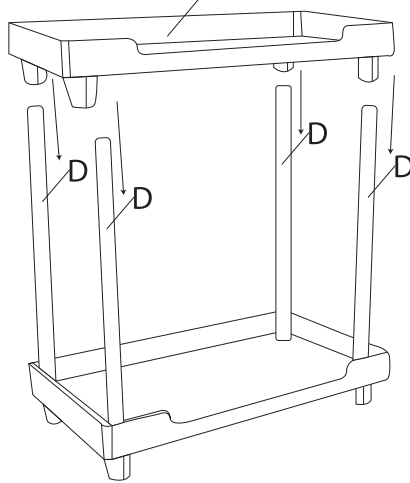

Step 3: Align the second tray (A) with all four long supporting rods (D). Secure into place as shown above.

4

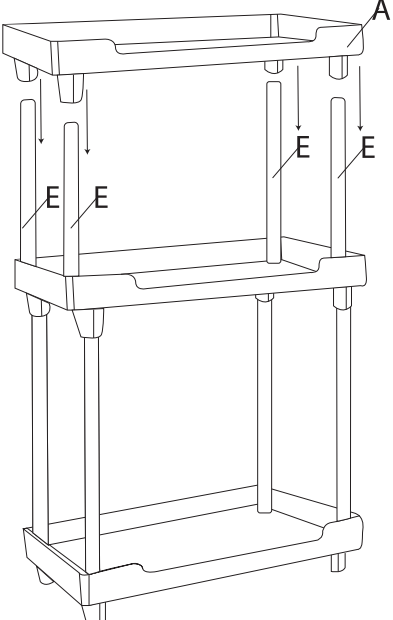

Step 4: Insert the short supporting rods (E) into the corners of the tray (A) as shown above. Add last tray (A) on top of short supporting rods (E).

5

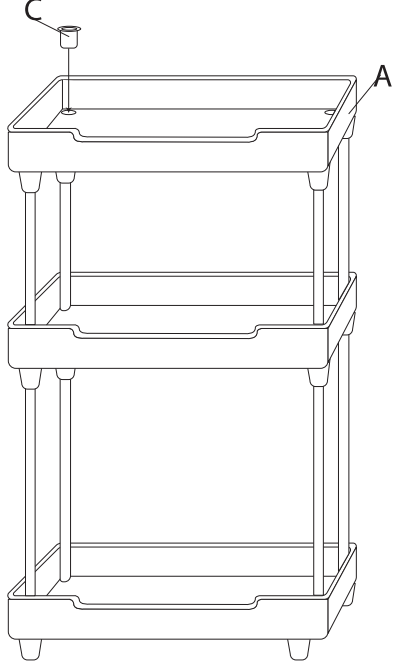

Step 5: Plug the four corners of top of the tray (A) with the four long upper stoppers (C). After making sure everything is secure, feel free to start using the shelf.