

# ASSEMBLY INSTRUCTIONS



*Fine Furniture for every stage of life*

***Queen Bed***

REVISION 0: 01/17/2017  
REVISION 1: 08/14/2018  
REVISION 2: 08/20/2018  
REVISION 3: 08/27/2019  
REVISION 4: 12/21/2020

**PAGE 1 OF 10**

# ASSEMBLY INSTRUCTIONS

## ASSEMBLY TIPS:

1. Remove hardware from box and sort by size.
2. Please check to see that all hardware and parts are present prior to start of assembly.
3. Please follow attached instructions in the same sequence as numbered to assure fast & easy assembly.



### WARNING!

1. Don't attempt to repair or modify parts that are broken or defective. Please contact the store immediately.
2. This product is for home use only and not intended for commercial establishments.



ASSEMBLY TIME

40 MINUTES

## PARTS IDENTIFICATION

### B1 ( BOX 1)

A HEADBOARD PANEL

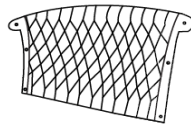

1PC

B HEADBOARD LEG

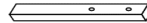

2PCS

C HEADBOARD SUPPORT  
PANEL



1PC

### B2 ( BOX 2)

D1 LEFT WING

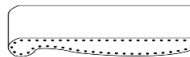

1PCS

D2 RIGHT WING



1PCS

E WING SUPPORT



2PCS

### B3 ( BOX 3)

F FOOTBOARD PANEL

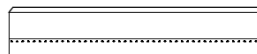

1PC

G1 LEFT BED RAIL



1PC

G2 RIGHT BED RAIL

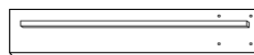

1PC

### NOTE:

Phillips head screw driver is required in the assembly process; however, manufacturer does not provide this item.

# ASSEMBLY INSTRUCTIONS

## ASSEMBLY TIPS:









1. Remove hardware from box and sort by size.
2. Please check to see that all hardware and parts are present prior to start of assembly.
3. Please follow attached instructions in the same sequence as numbered to assure fast & easy asse



### WARNING!

1. Don't attempt to repair or modify parts that are broken or defective. Please contact the store immediately.
2. This product is for home use only and not intended for commercial establishments.

## PARTS IDENTIFICATION

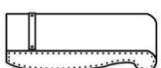
H	BED SLAT WITHOUT HOLE		10PCS
I	BED SLAT WITH HOLES		3PCS
J	BED SLAT SUPPORT		3PCS
K	FOOTBOARD LEG		2PCS
L	CENTER RAIL		1PCS
M	CENTER RAIL SUPPORT		1PCS
HB	FROM BOX 1 HEADBOARD COMPLETE		1PC
ER 1	FROM BOX 2 WING COMPLETE		1PC
ER 2	FROM BOX 2 WING COMPLETE		1PC

Phillips head screw driver is required in the assembly process; however, manufacturer does not provide this item.

# ASSEMBLY INSTRUCTIONS

## ASSEMBLY TIPS:

1. Remove hardware from box and sort by size.
2. Please check to see that all hardware and parts are present prior to start of assembly.
3. Please follow attached instructions in the same sequence as numbered to assure fast & easy assembly.













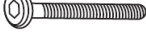

### WARNING!

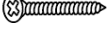
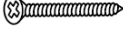
1. Don't attempt to repair or modify parts that are broken or defective. Please contact the store immediately.
2. This product is for home use only and not intended for commercial establishments.

## HARDWARE IDENTIFICATION

### BOX 3 - HARDWARE PACK

1	<b>ALLEN WRENCH</b> (Φ6 - BLK)		1PC
2	<b>BOLT 1</b> (Φ6 X 30mm - RBW)		4PCS
3	<b>BOLT 2</b> (Φ6 X 45mm - RBW)		12PCS
4	<b>BOLT 3</b> (Φ6 X 60mm - RBW)		5PCS
5	<b>BOLT 4</b> (Φ6 X 90mm - RBW)		8PCS
6	<b>SHORT FLAT HEAD SCREW</b> (Φ4 X 16mm - RBW)		8PCS
7	<b>MEDIUM FLAT HEAD SCREW</b> (Φ4 X 32mm - RBW)		27PCS
8	<b>LONG FLAT HEAD SCREW</b> (Φ4 X 45mm - RBW)		4PCS
9	<b>BIG FLAT WASHER</b> (Φ3/8 X 25 X 1 - RBW)		24PCS
10	<b>MEDIUM FLAT WASHER</b> (Φ7 X 19 X 2 - RBW)		24PCS
11	<b>SMALL FLAT WASHER</b> (Φ6 X 13 X 1 - RBW)		4PCS
12	<b>LOCK WASHER</b> (Φ6 - RBW)		24PCS
13	<b>LEVELER</b> (Φ6 X 23mm - RBW)		3PCS

### NOTE:

Phillips head screw driver is required in the assembly process; however, manufacturer does not provide this item.

# ASSEMBLY INSTRUCTIONS

## STEP 1

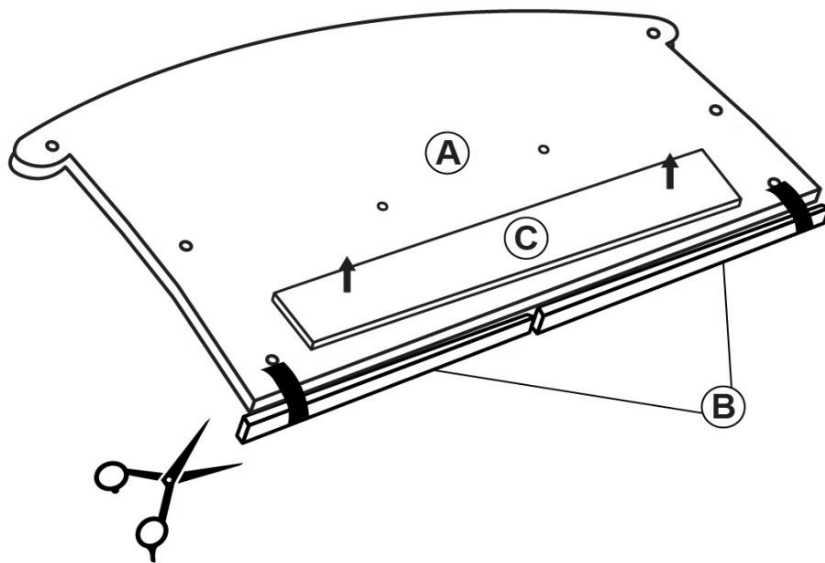

## STEP 2

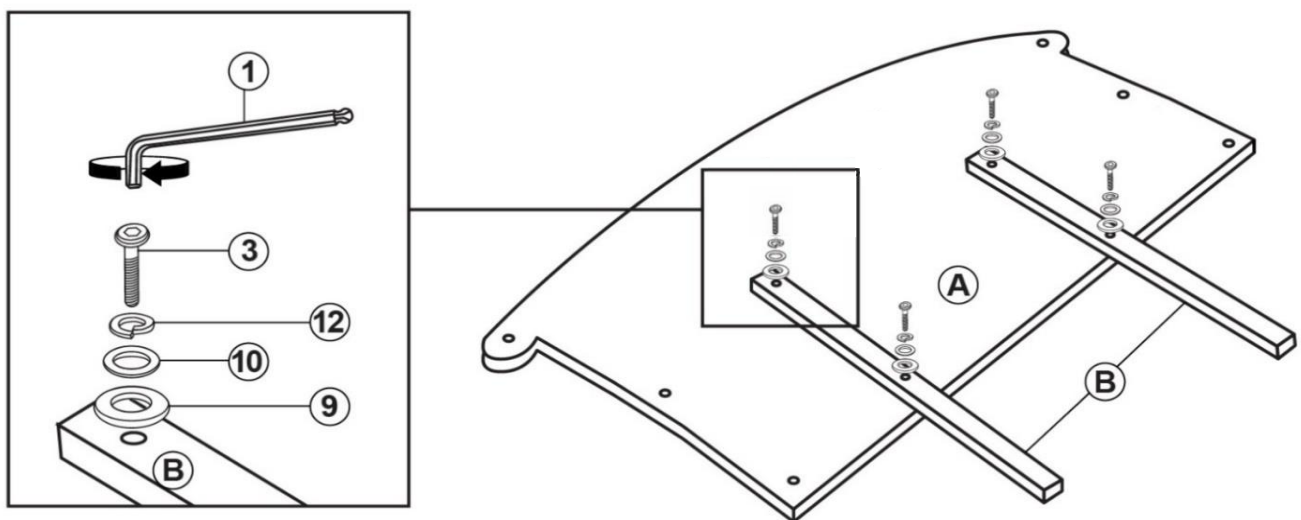

# ASSEMBLY INSTRUCTIONS

## STEP 3

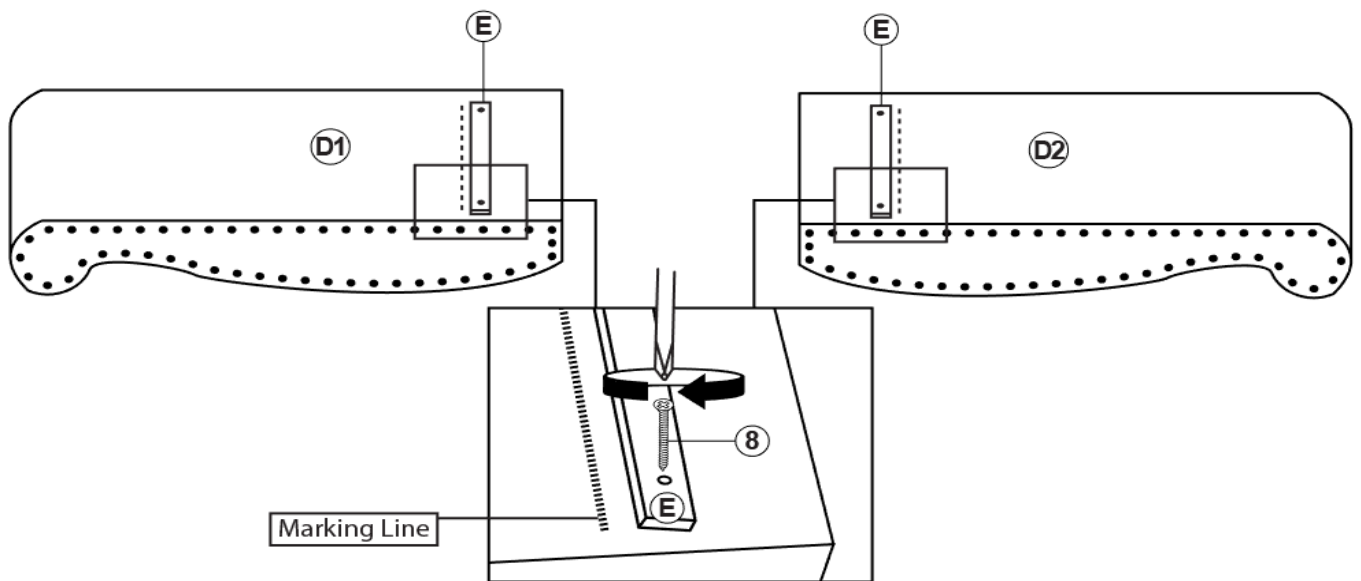

\*Assemble wing support at the bottom of the marking line.

## STEP 4

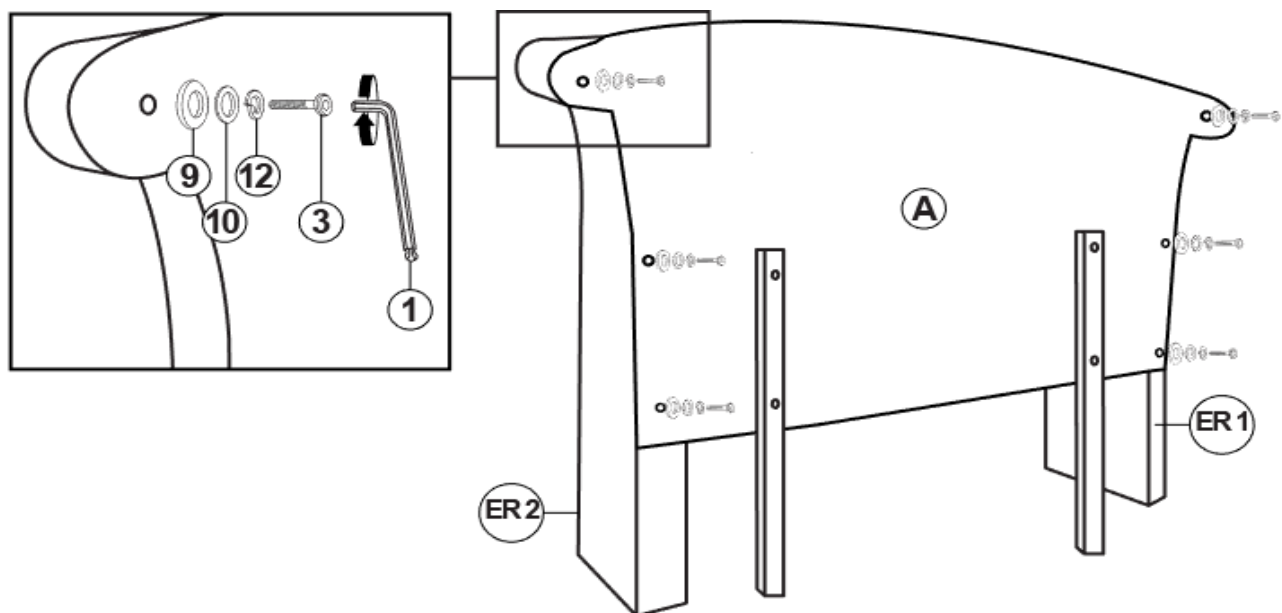

# ASSEMBLY INSTRUCTIONS

## STEP 5

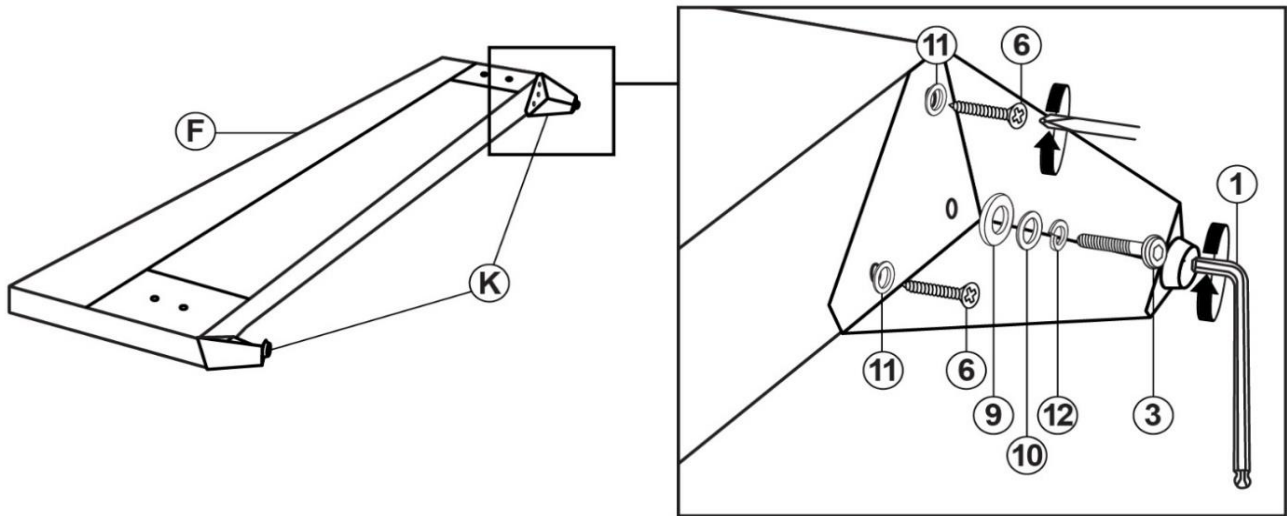

## STEP 6

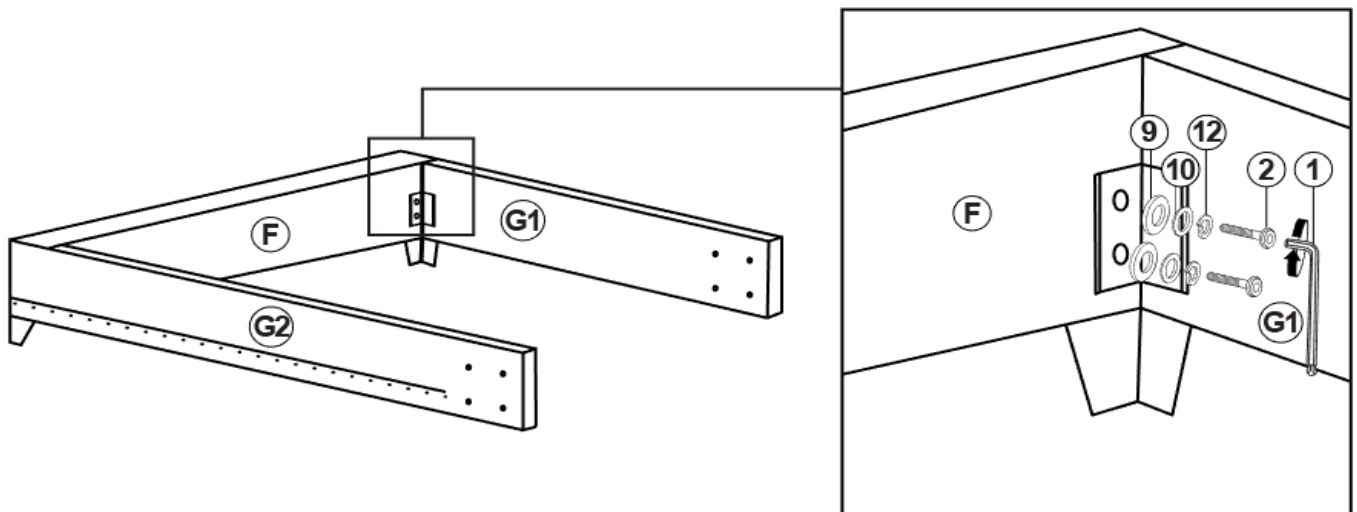

# ASSEMBLY INSTRUCTIONS

## STEP 7

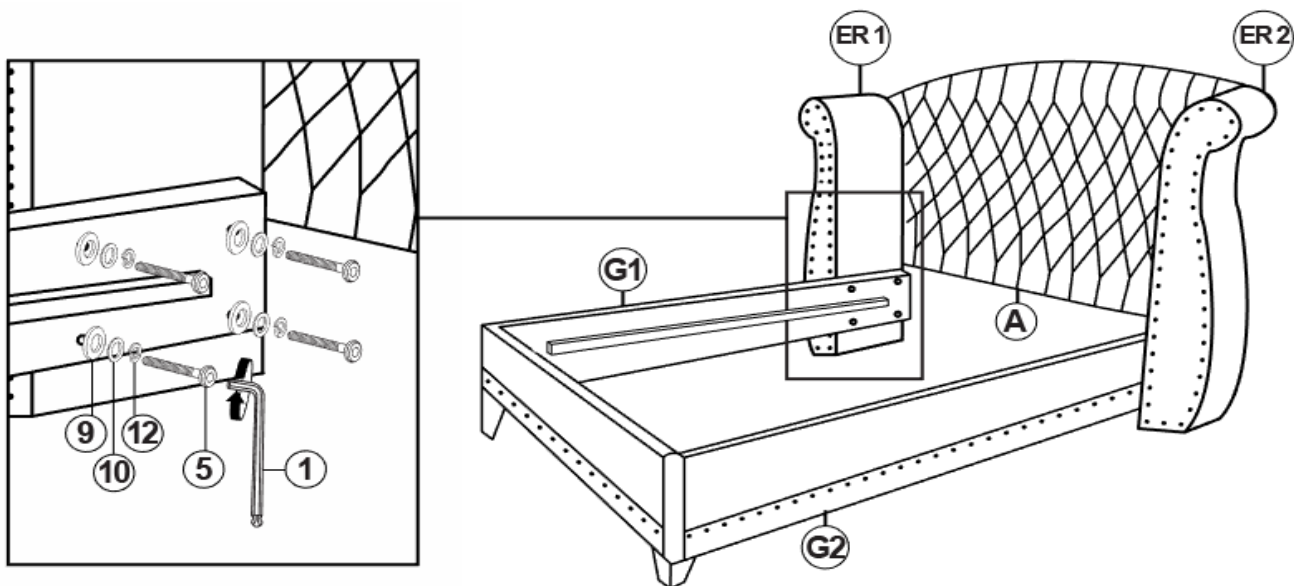

## STEP 8

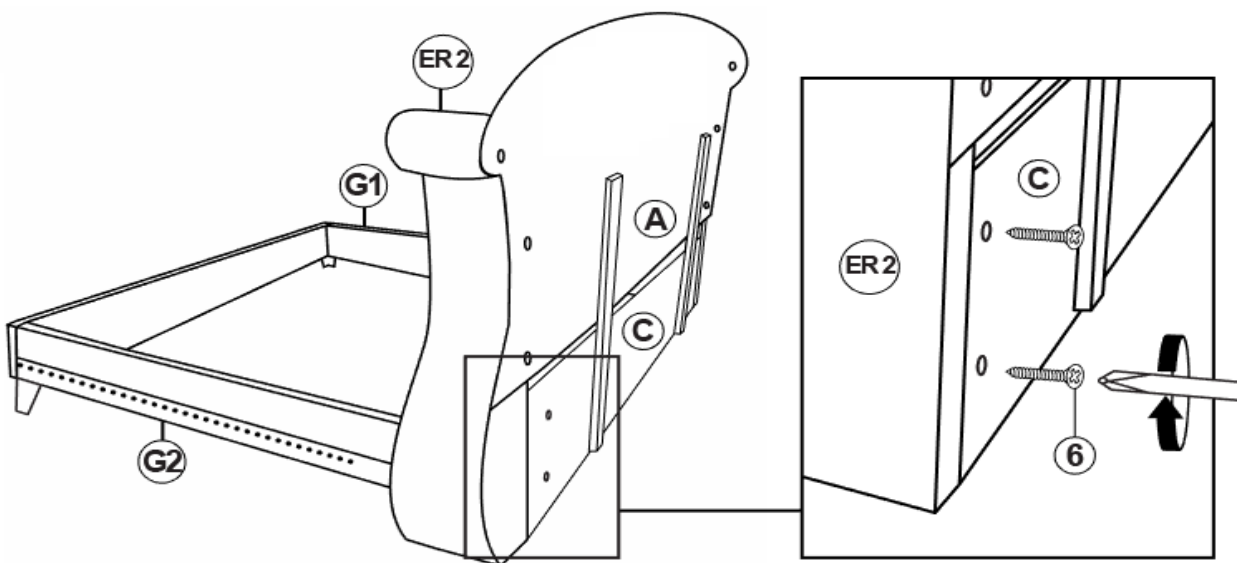

# ASSEMBLY INSTRUCTIONS

## STEP 9

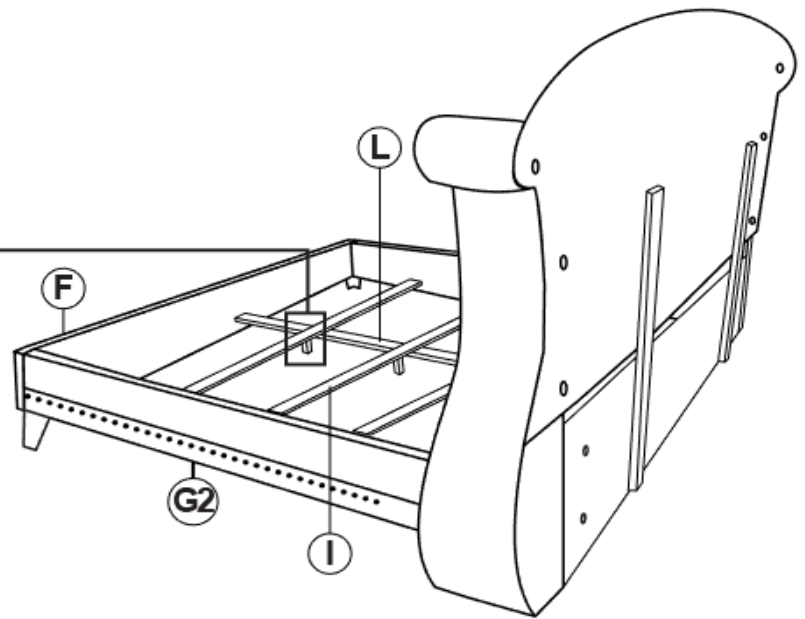
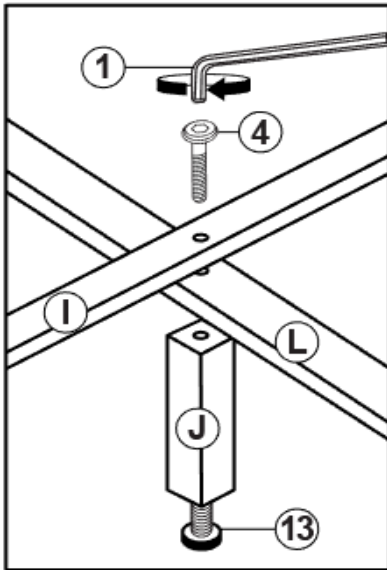

## STEP 10

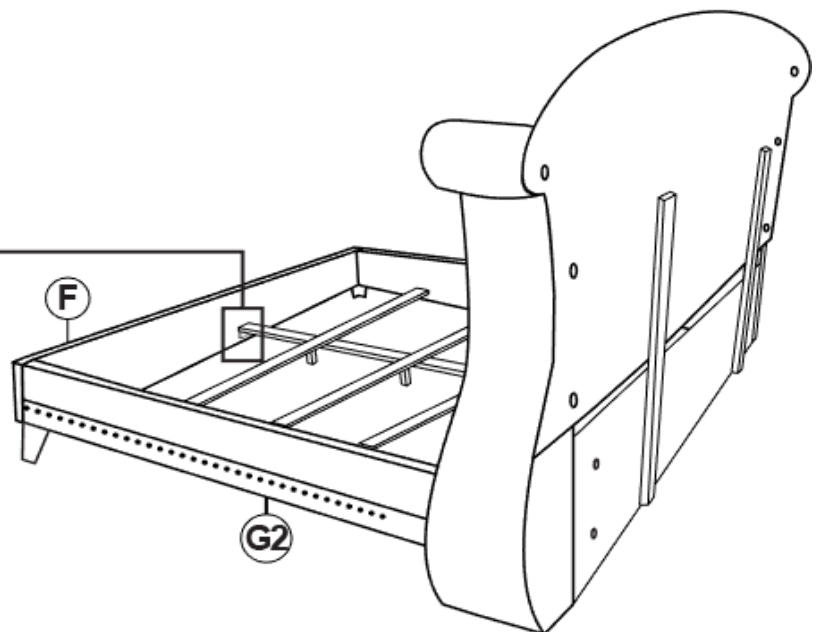
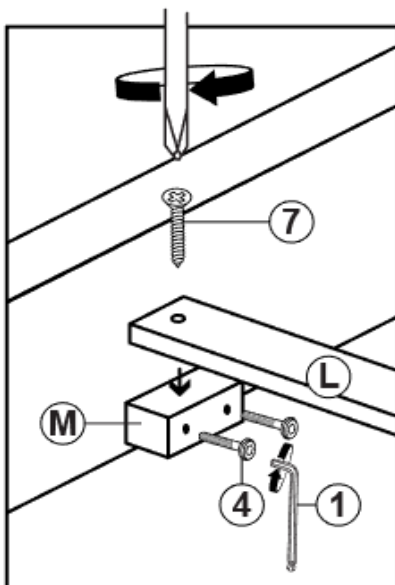

# ASSEMBLY INSTRUCTIONS

## STEP 11

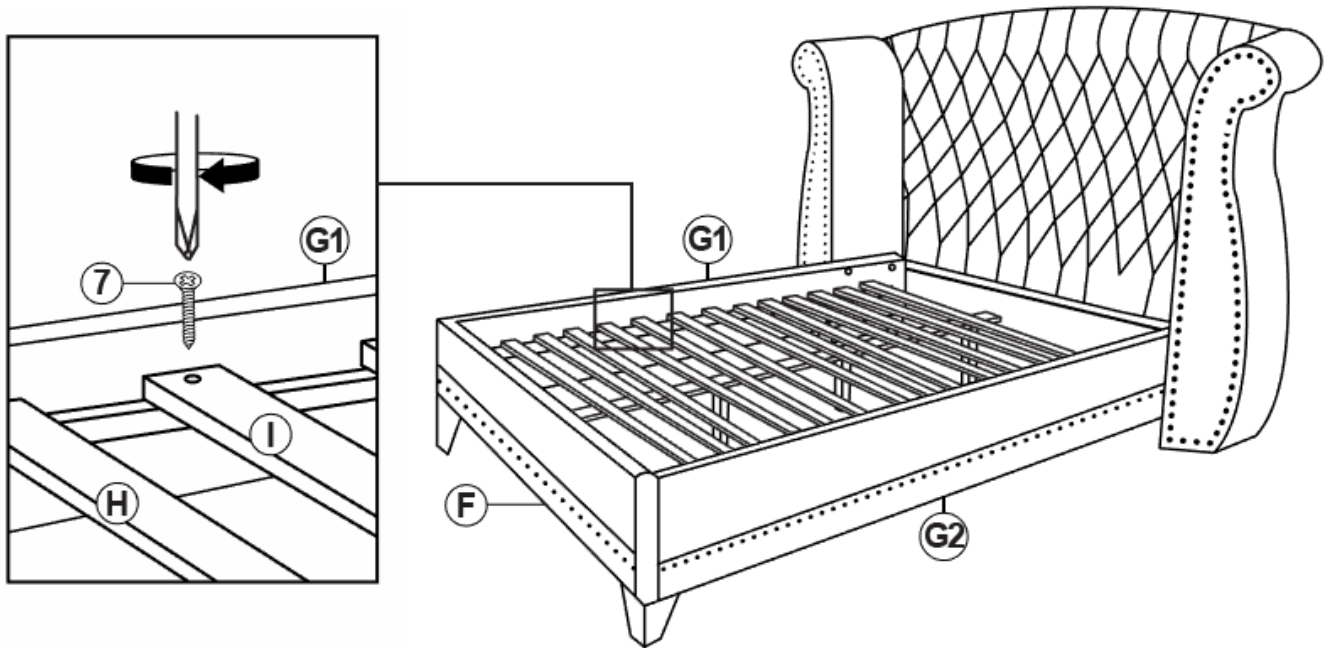

## STEP 12

### COMPLETE

