

ASSEMBLY INSTRUCTIONS



Fine Furniture for every stage of life

Full Bed

ASSEMBLY INSTRUCTIONS

ASSEMBLY TIPS:

1. Remove hardware from box and sort by size.
2. Please check to see that all hardware and parts are present prior to start of assembly.
3. Please follow attached instructions in the same sequence as numbered to assure fast & easy assembly.



WARNING!

1. Don't attempt to repair or modify parts that are broken or defective. Please contact the store immediately.
2. This product is for home use only and not intended for commercial establishments

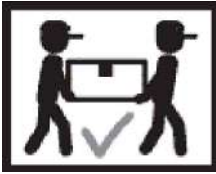

ASSEMBLY TIME

20 MINUTES

PARTS IDENTIFICATION

B1 (BOX 1)

A HEADBOARD PANEL

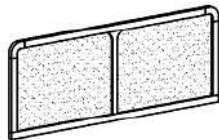

1PC

B FOOTBOARD



1PC

C HEADBOARD LEG



2PCS

D BED SLAT



4PCS

E BED SLAT SUPPORT WITH LEVELER



4PCS

B2 (BOX 2)

F BED RAIL



2PCS

NOTE:

Phillips head screw driver is required in the assembly process; however, manufacturer does not provided this item.

ASSEMBLY INSTRUCTIONS

ASSEMBLY TIPS:

1. Remove hardware from box and sort by size.
2. Please check to see that all hardware and parts are present prior to start of assembly.
3. Please follow attached instructions in the same sequence as numbered to assure fast & easy assembly.













WARNING!

1. Don't attempt to repair or modify parts that are broken or defective. Please contact the store immediately.
2. This product is for home use only and not intended for commercial establishments

HARDWARE IDENTIFICATION

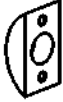
(BOX 1) - HARDWARE PACK IS LOCATED IN (B1)

1	BOLT (M6 x 50mm - BLK)		4PCS	7	FLAT HEAD SCREW (M4 x 25mm - BLK)		8PCS
2	WOOD DOWEL (M10Ø x 40mm)		10PCS	8	ALLEN WRENCH (M4 x 100mm - BLK)		1PC
3	THREADED BOLT (M6 x 60mm - RBW)		8PCS	9	FLAT WASHER (1/4" x 19 Ø - BLK)		4PCS
4	HEX NUT (M6 - RBW)		8PCS	10	LOCK WASHER (1/4" x 12 Ø - BLK)		4PCS
5	HALF ROUND NUT (Ø7.5mm - RBW)		8PCS	11	WRENCH (M6 x 10mm - RBW)		1PC
6	U-SQUARE WASHER (M8 x 16 x 25mm - RBW)		8PCS				

NOTE:

Phillips head screw driver is required in the assembly process; however, manufacturer does not provided this item.

ASSEMBLY INSTRUCTIONS

STEP 1

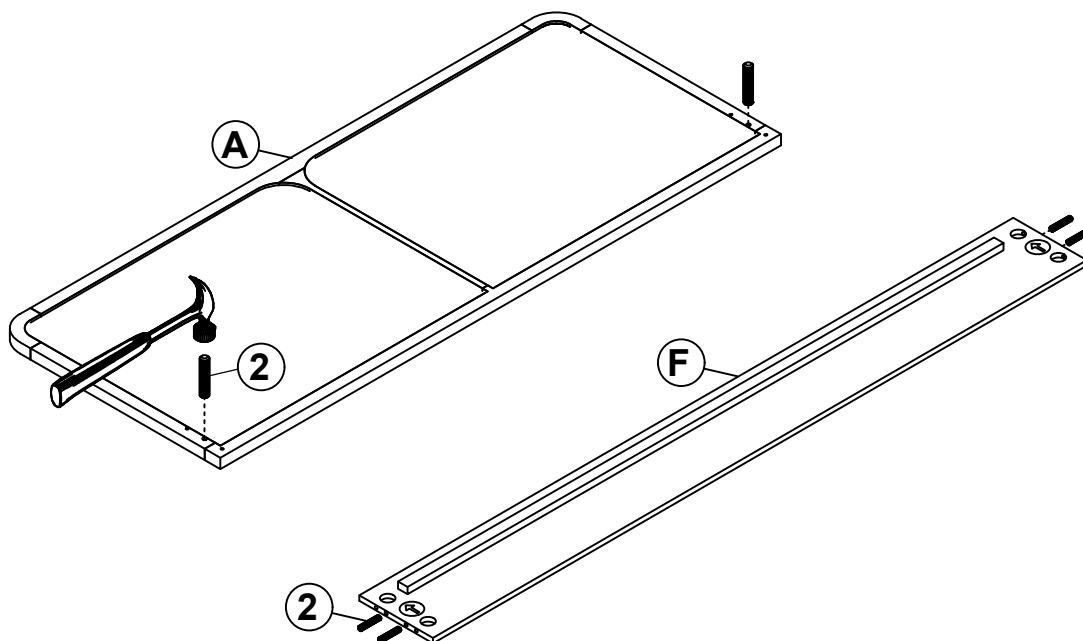

STEP 2

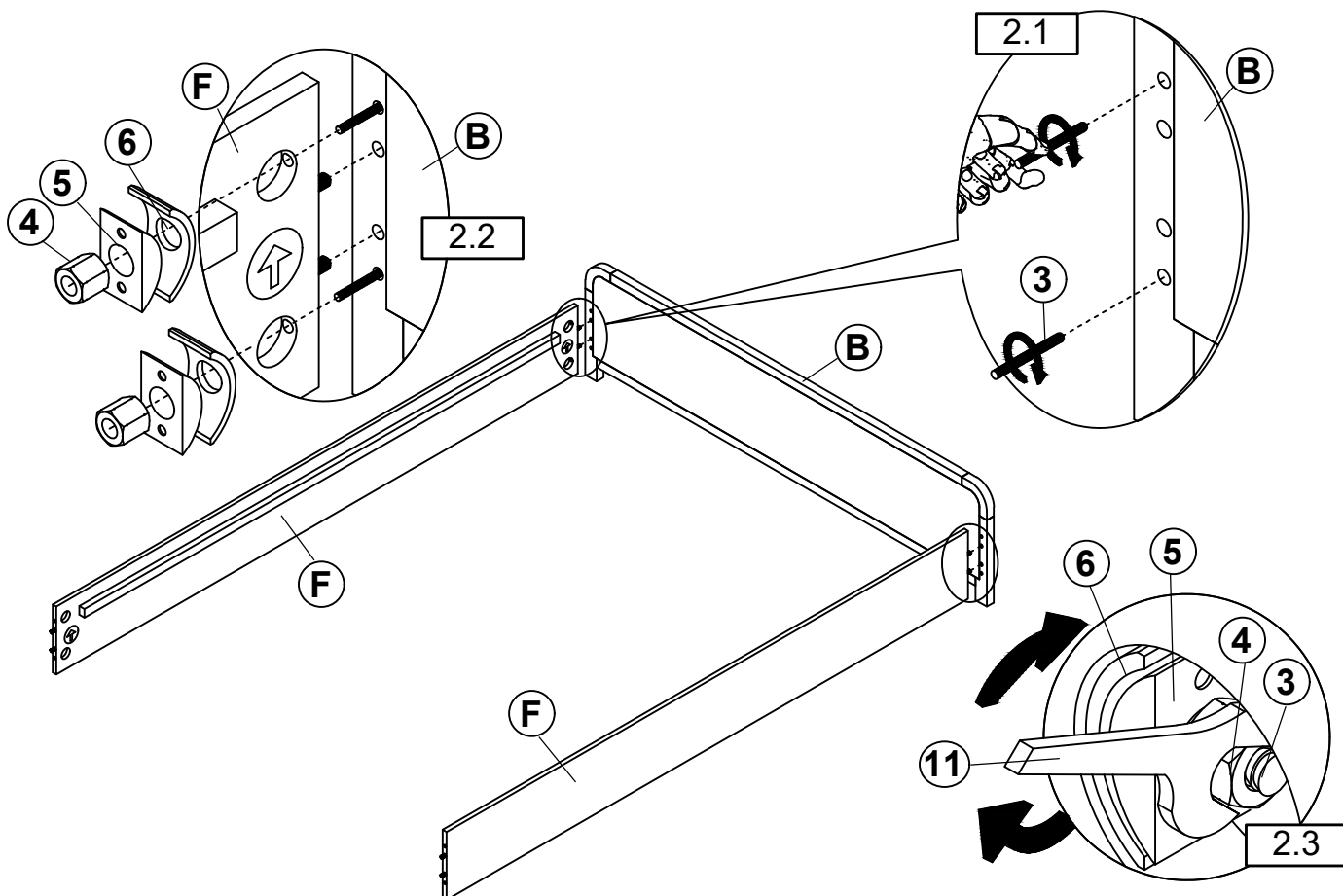

ASSEMBLY INSTRUCTIONS

STEP 3

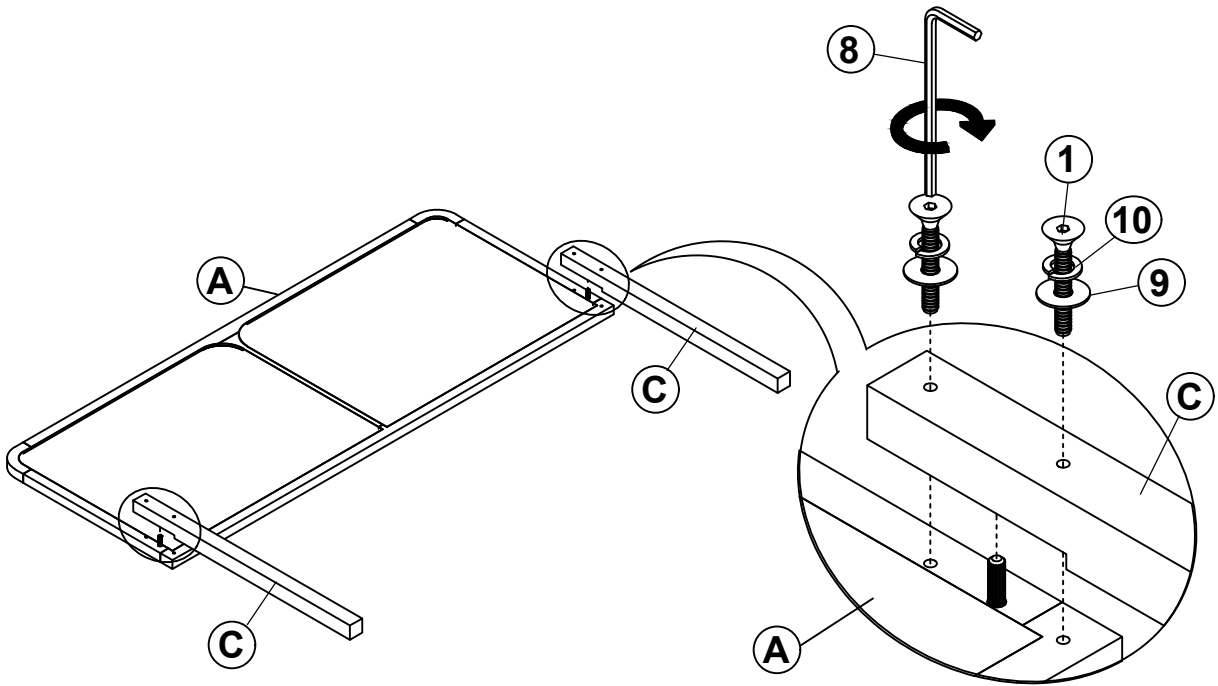

STEP 4

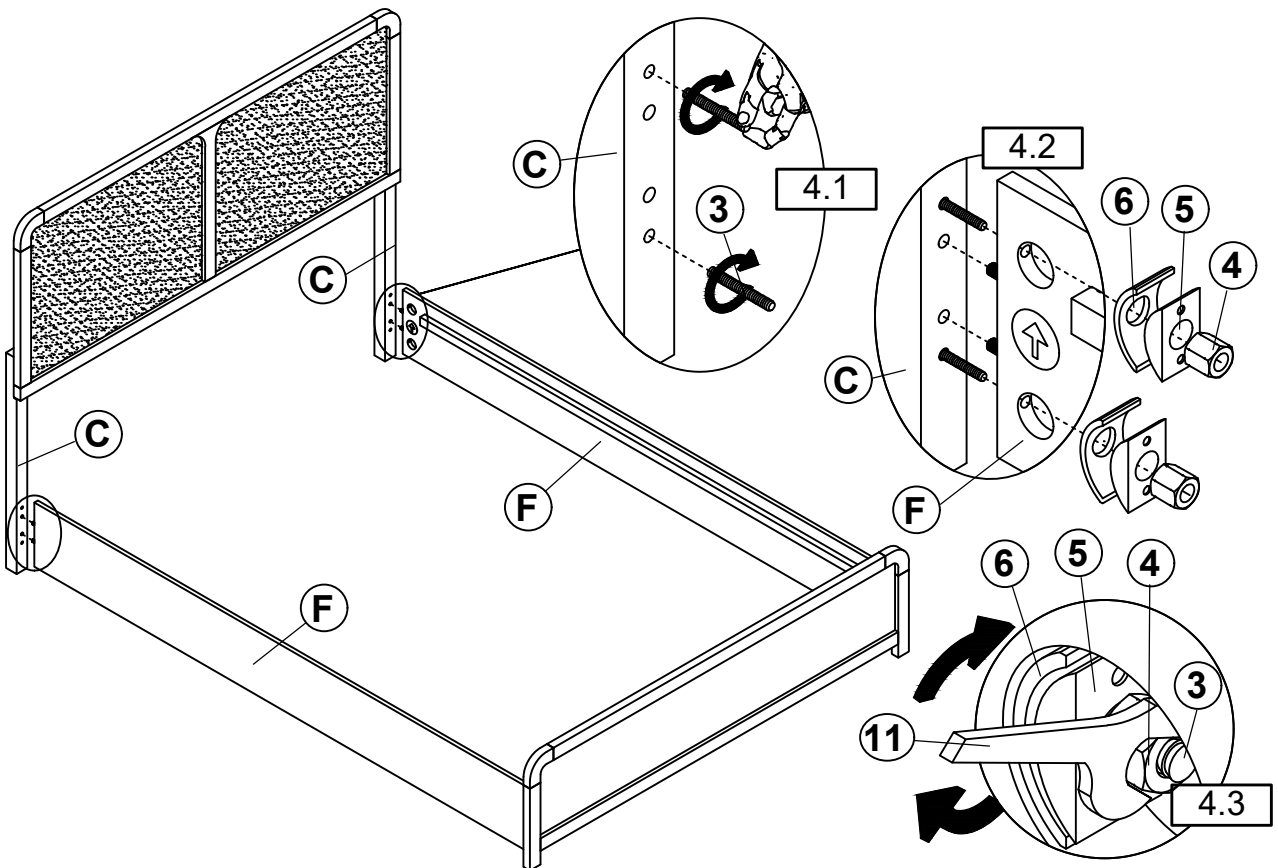

ASSEMBLY INSTRUCTIONS

STEP 5

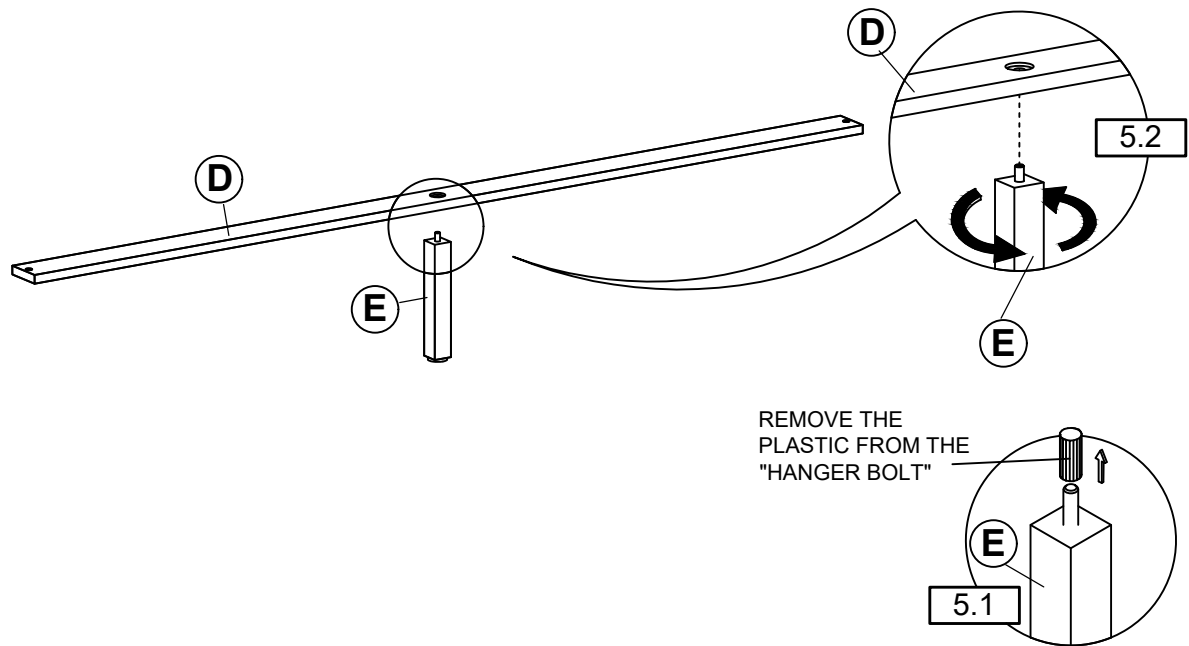

STEP 6

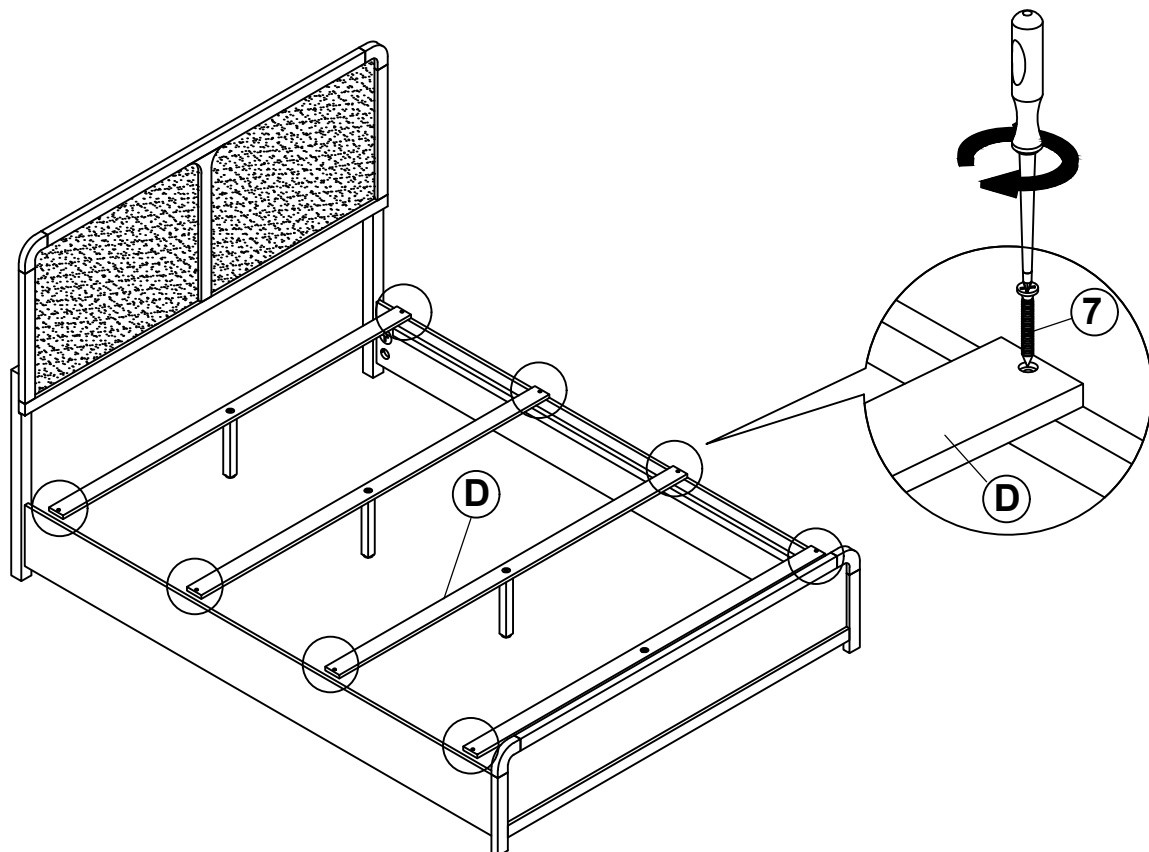

ASSEMBLY INSTRUCTIONS

STEP 7

COMPLETE

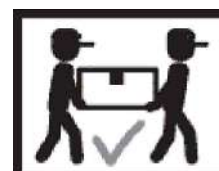
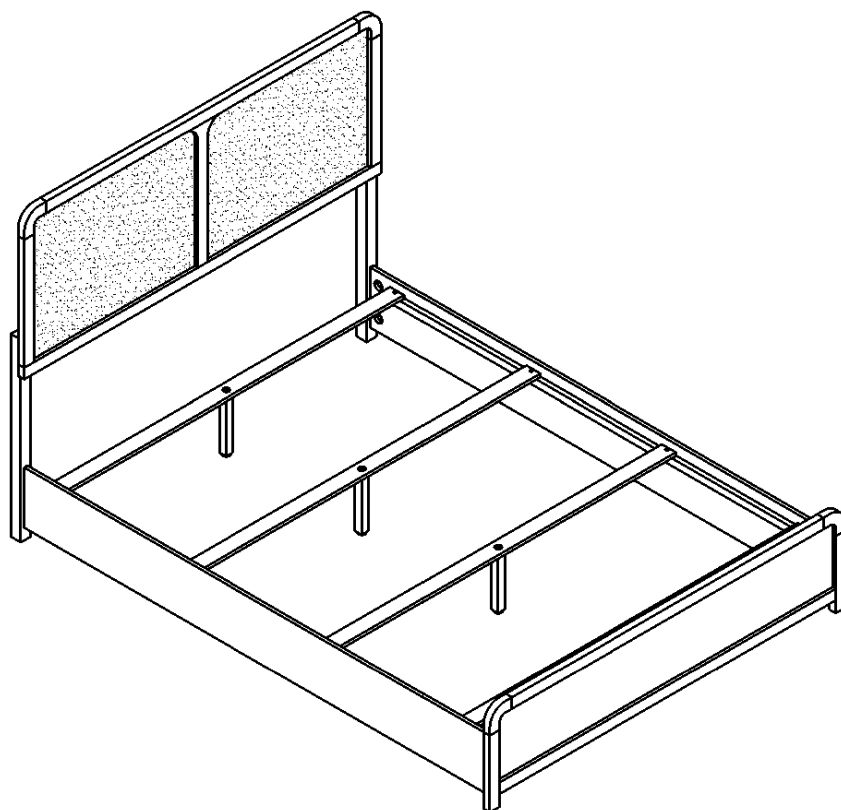

Inner size: 54.50"W X 77.00"D

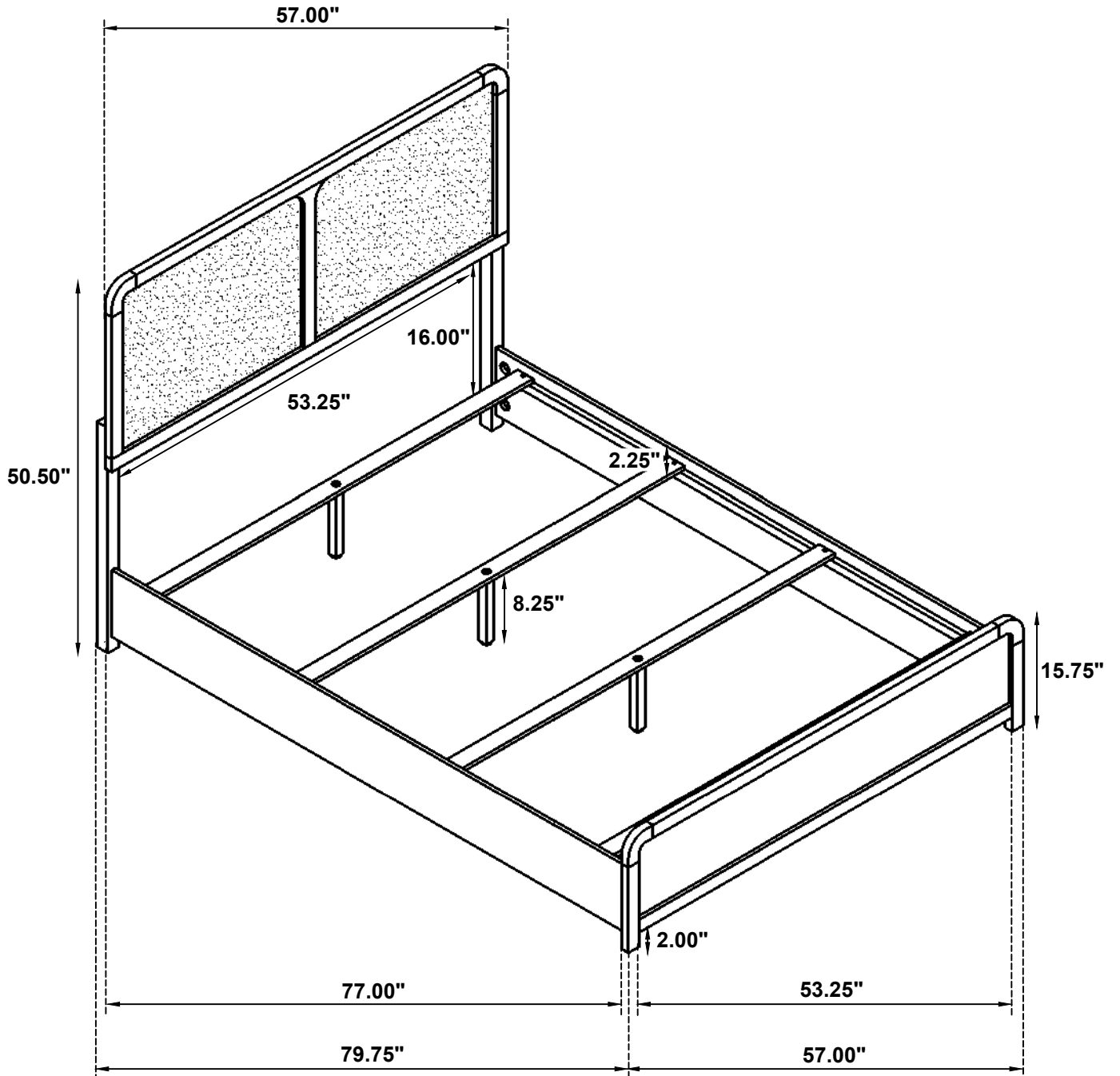

Note : Dimension tolerance $\pm 5\%$