

- Ⓛ D **Montageanleitung**
- Ⓛ NL **Handleiding voor de montage**
- Ⓛ TR **Montaj talimatı**
- Ⓛ F **Notice de montage**
- Ⓛ CZ **Montážní návod**
- Ⓛ HU **Szerelési útmutató**
- Ⓛ GB **Assembly instructions**
- Ⓛ PL **Instrukcja montażu**
- Ⓛ RU **Инструкция по монтажу**
- Ⓛ IT **Istruzioni di montaggio**
- Ⓛ SK **Návod na montáž**
- Ⓛ RO **Instrucțiuni de montaj**

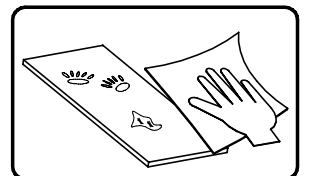
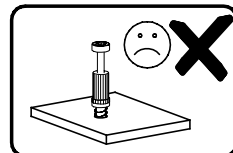
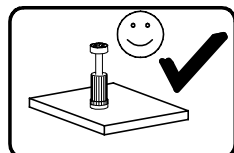
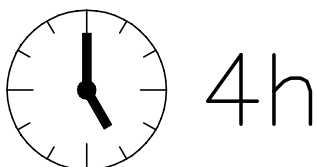
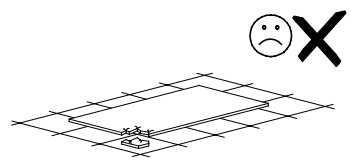
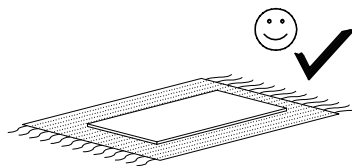
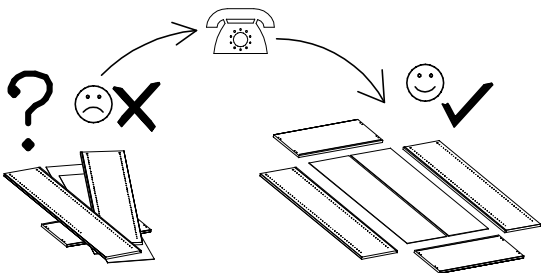
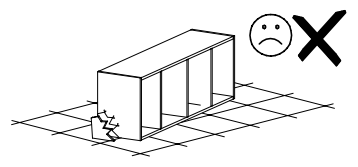
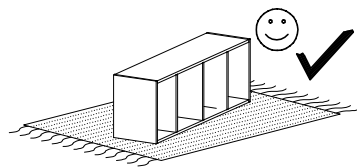
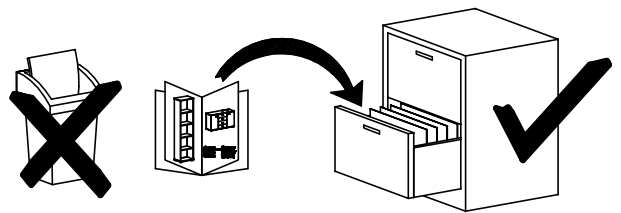
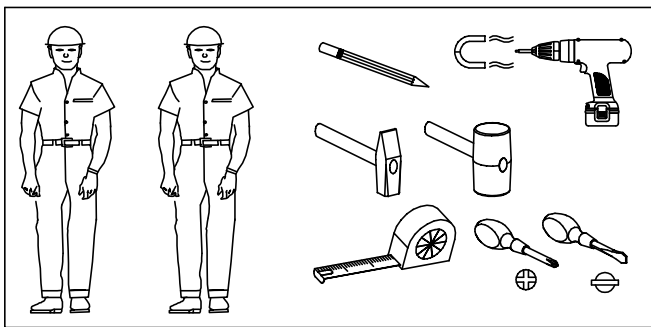

Name • Nom • Nome • Naam • Nazwa • Jméno  
• Názov • Név • Denumire • Isim • Имя

Nr • No • N° • Номер • Č • Sz

Typ • Type • Tip • Típus • Tipo • Tun

---

VITRINE

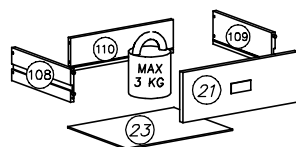
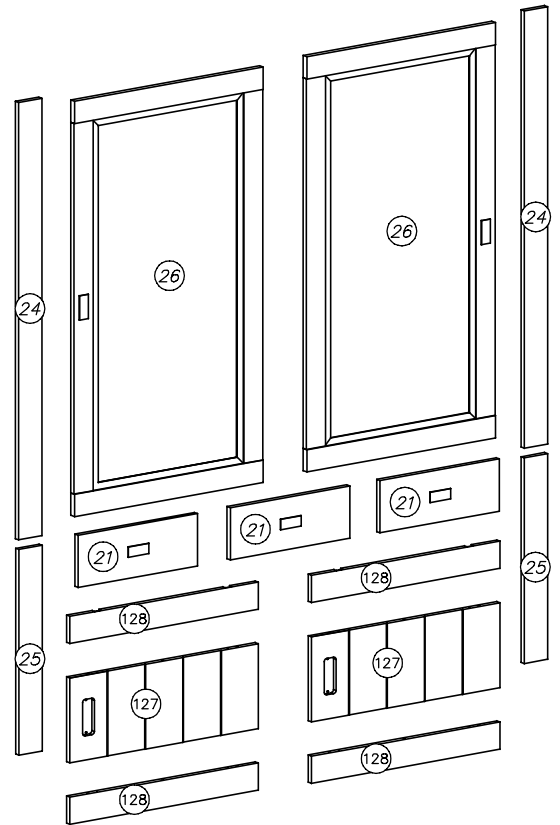
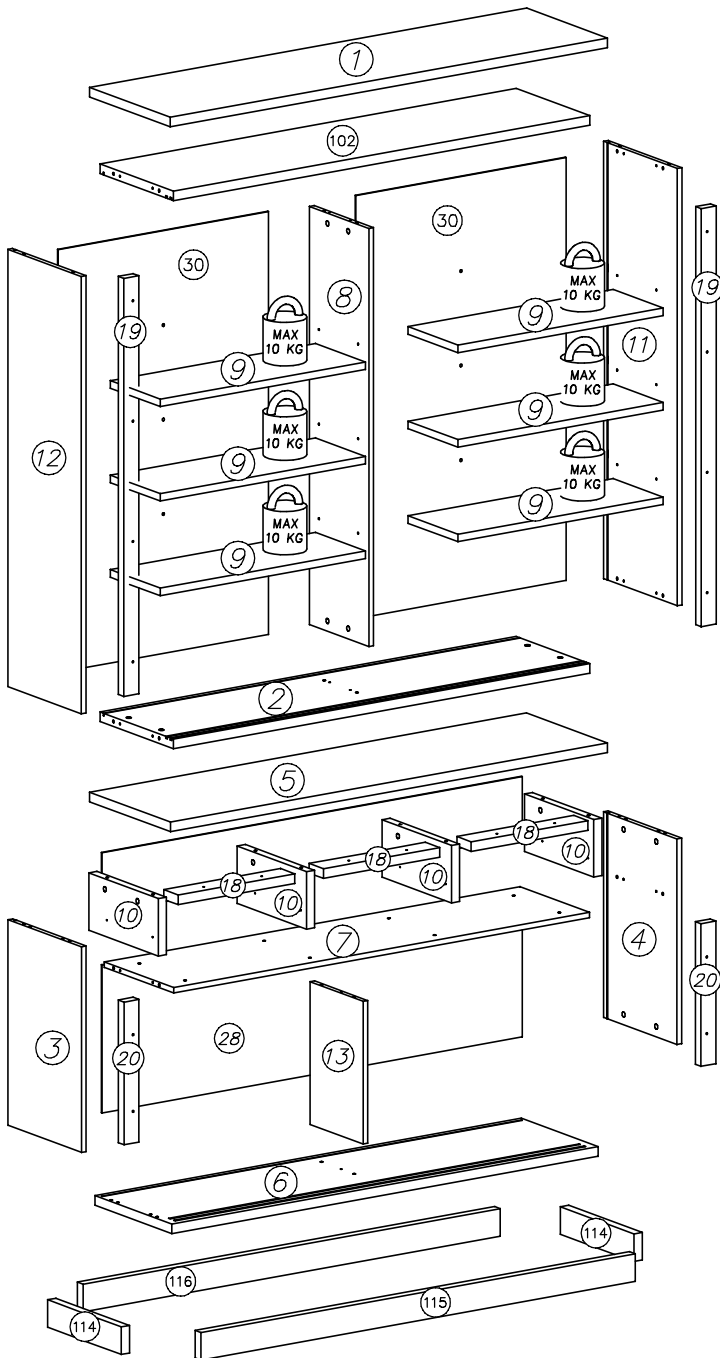
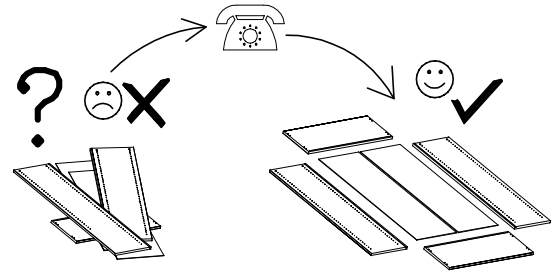
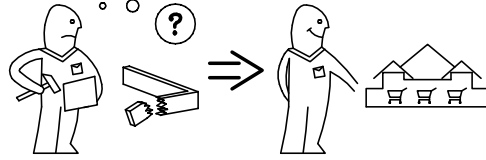
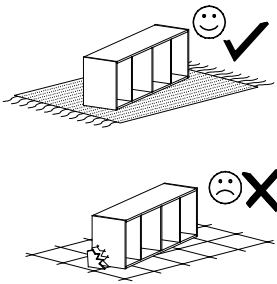

Name • Nom • Nome • Naam • Nazwa • Jméno  
• Názov • Név • Denumire • Isim • Название

Nr • No • N° • Номер • Č • Sz

Typ • Type • Tip • Típus • Tipo • Tun

---

VITRINE

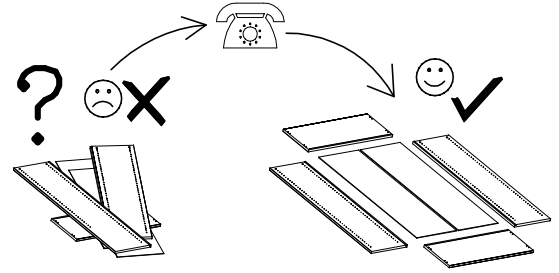
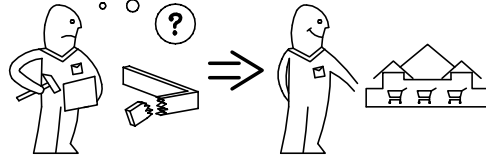
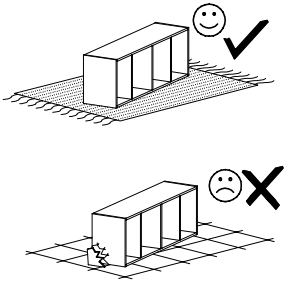

| nr | L[mm] | B[mm] | T[mm] | Menge | Collt |
|----|-------|-------|-------|-------|-------|
| 1  | 1499  | 396   | 28    | 1     | 3/5   |
| 2  | 1429  | 360   | 28    | 1     | 3/5   |
| 3  | 598   | 360   | 16    | 1     | 2/5   |
| 4  | 598   | 360   | 16    | 1     | 2/5   |
| 5  | 1499  | 396   | 28    | 1     | 1/5   |
| 6  | 1463  | 377   | 28    | 1     | 1/5   |
| 7  | 1429  | 340   | 16    | 1     | 1/5   |
| 8  | 1216  | 291   | 16    | 1     | 4/5   |
| 9  | 706   | 260   | 22    | 6     | 4/5   |
| 10 | 167   | 340   | 28    | 4     | 2/5   |
| 11 | 1272  | 360   | 16    | 1     | 4/5   |
| 12 | 1272  | 360   | 16    | 1     | 4/5   |
| 13 | 415   | 260   | 16    | 1     | 2/5   |
| 18 | 400   | 70    | 28    | 3     | 1/5   |
| 19 | 1216  | 51    | 28    | 2     | 3/5   |
| 20 | 415   | 51    | 28    | 2     | 1/5   |
| 21 | 410   | 152   | 16    | 3     | 2/5   |

| nr  | L[mm] | B[mm] | T[mm] | Menge | Collt |
|-----|-------|-------|-------|-------|-------|
| 23  | 377   | 301   | 3     | 3     | 1/5   |
| 24  | 1272  | 80    | 16    | 2     | 4/5   |
| 25  | 598   | 80    | 16    | 2     | 2/5   |
| 26  | 647   | 1208  | 18    | 2     | 5/5   |
| 28  | 429   | 1441  | 3     | 1     | 1/5   |
| 29  | 181   | 1441  | 3     | 1     | 1/5   |
| 30  | 1228  | 720   | 3     | 2     | 5/5   |
| 102 | 1429  | 360   | 28    | 1     | 3/5   |
| 108 | 300   | 100   | 12    | 3     | 1/5   |
| 109 | 300   | 100   | 12    | 3     | 1/5   |
| 110 | 367   | 100   | 12    | 3     | 1/5   |
| 114 | 361   | 80    | 28    | 2     | 1/5   |
| 115 | 1490  | 80    | 28    | 1     | 1/5   |
| 116 | 1431  | 80    | 28    | 1     | 1/5   |
| 127 | 647   | 247   | 16    | 2     | 5/5   |
| 128 | 647   | 79    | 16    | 4     | 5/5   |



|                                   |                                 |                                  |                                 |                                  |                                    |
|-----------------------------------|---------------------------------|----------------------------------|---------------------------------|----------------------------------|------------------------------------|
|                                   | <b>B3</b><br><br>∅8x50 x...(12) | <b>F15</b><br><br>x...(14)       | <b>A6</b><br><br>∅7x40 x...(12) | <b>K14</b><br><br>∅15x19 x...(8) | <b>N1</b><br><br>M4x9 x...(6)      |
| <b>M19</b><br><br>x...(2)         | <b>A1</b><br><br>∅7x50 x...(8)  | <b>W2</b><br><br>x...(1)         | <b>G1</b><br><br>4x13 x...(12)  | <b>H3</b><br><br>280mm x...(6)   |                                    |
| <b>G22</b><br><br>3,5x16 x...(30) | <b>E72</b><br><br>96mm x...(7)  | <b>T39</b><br><br>x...(8)        | <b>T40</b><br><br>x...(8)       | <b>G23</b><br><br>4x40 x...(18)  | <b>F4</b><br><br>x...(4)           |
| <b>K5</b><br><br>x...(34)         | <b>P4</b><br><br>x...(12)       | <b>K1</b><br><br>∅15x12 x...(26) | <b>B1</b><br><br>∅8x35 x...(40) | <b>G2</b><br><br>3x20 x...(38)   | <b>G34</b><br><br>3,5x16 x...(120) |
| <b>F2</b><br><br>x...(24)         | <b>F12</b><br><br>x...(14)      | <b>I7</b><br><br>x...(34)        | <b>I1</b><br><br>x...(24)       | <b>S2</b><br><br>x...(25)        | <b>W1</b><br><br>x...(4)           |

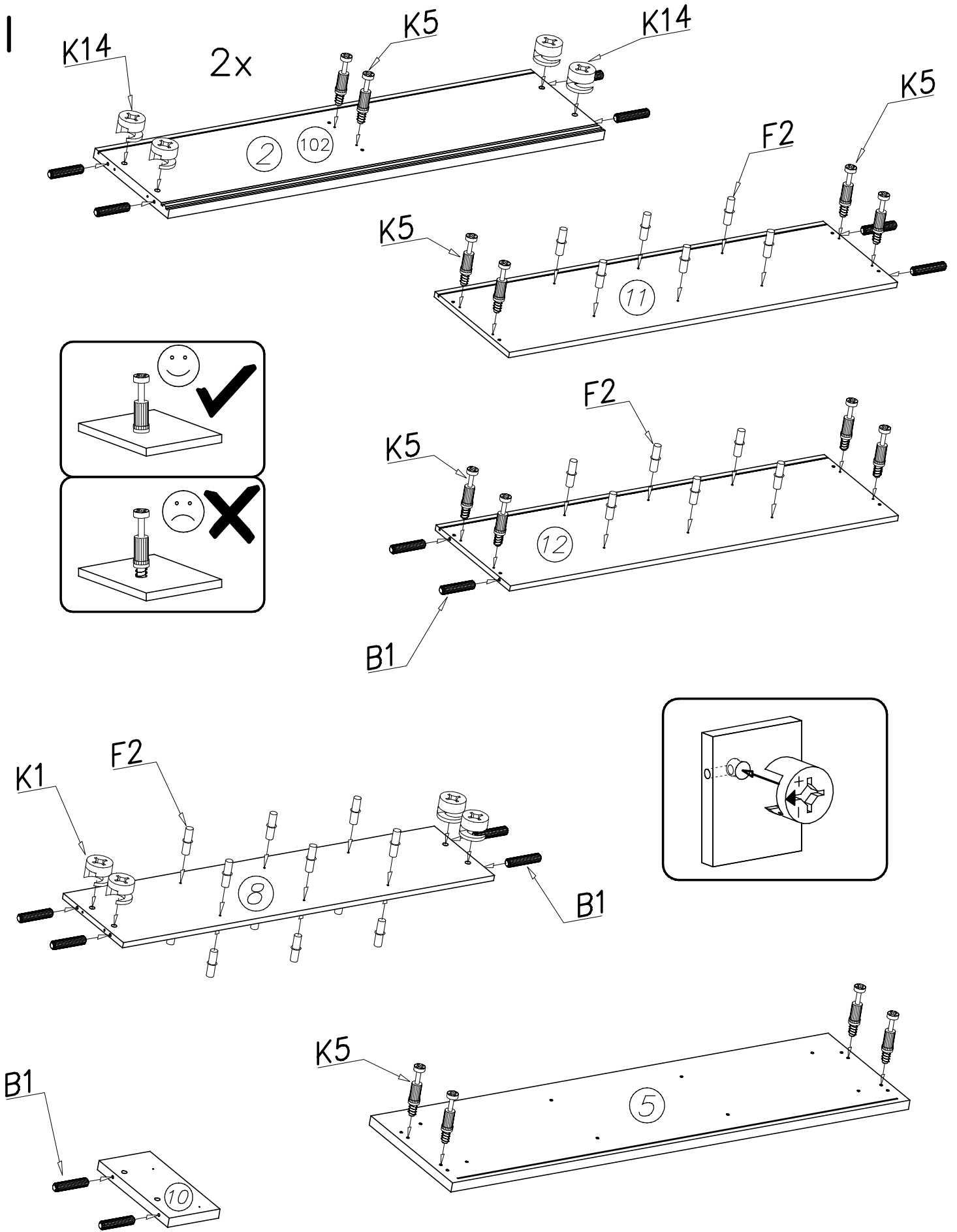

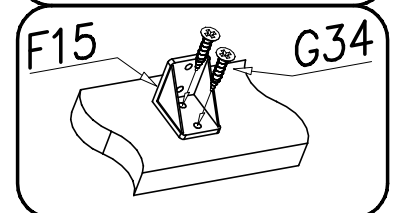
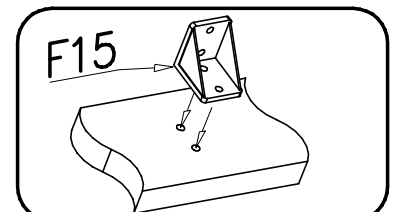
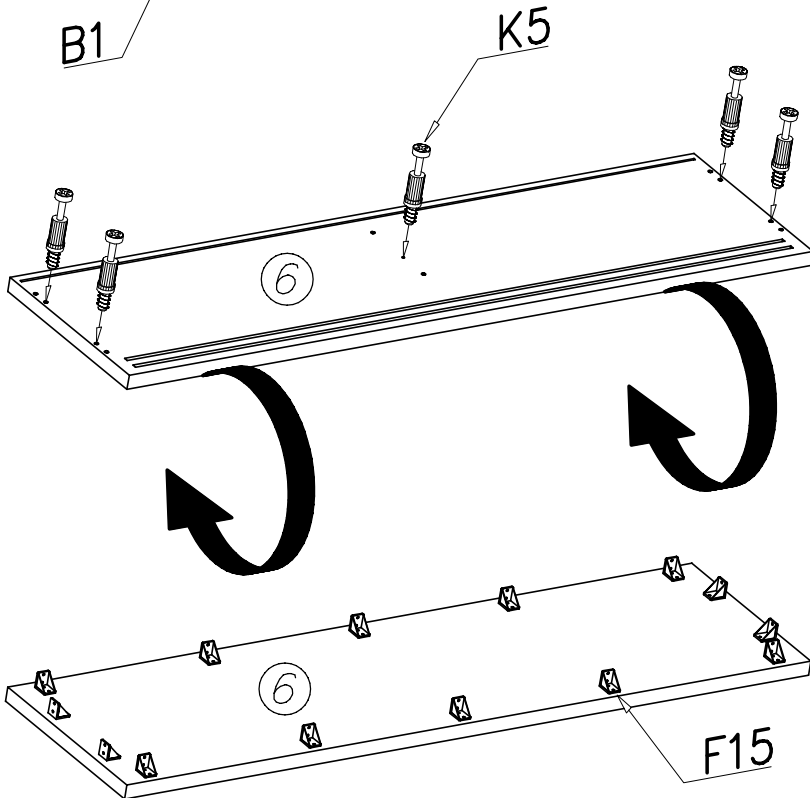
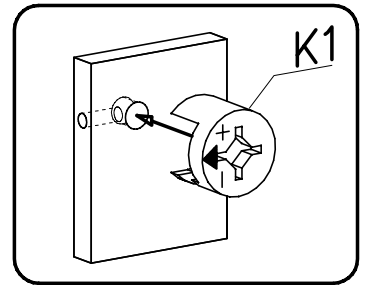
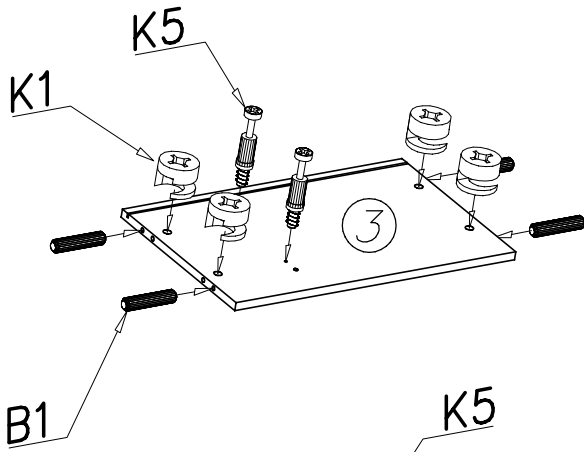
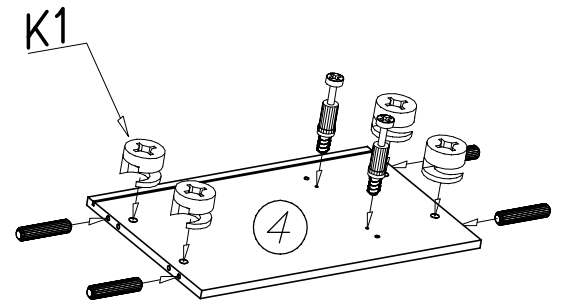
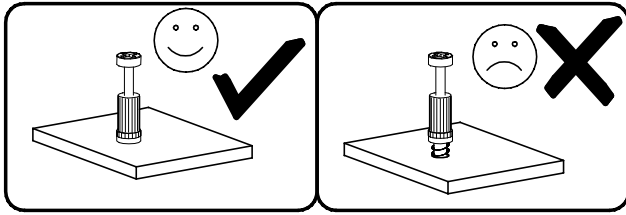
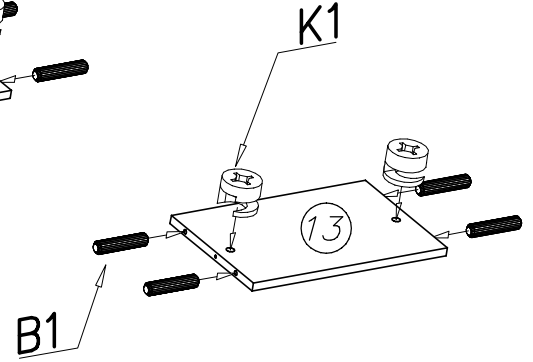
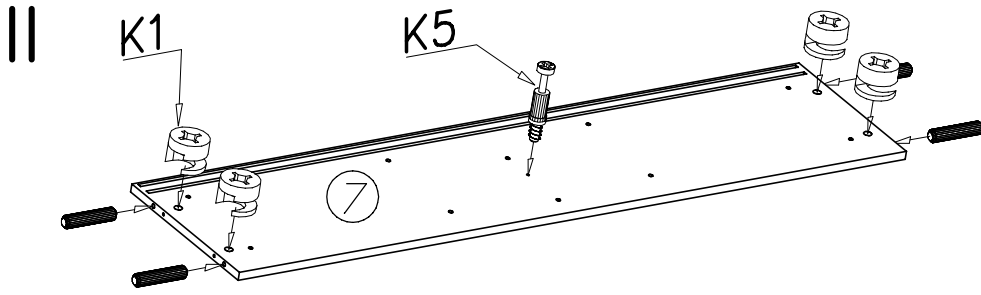

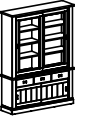

III

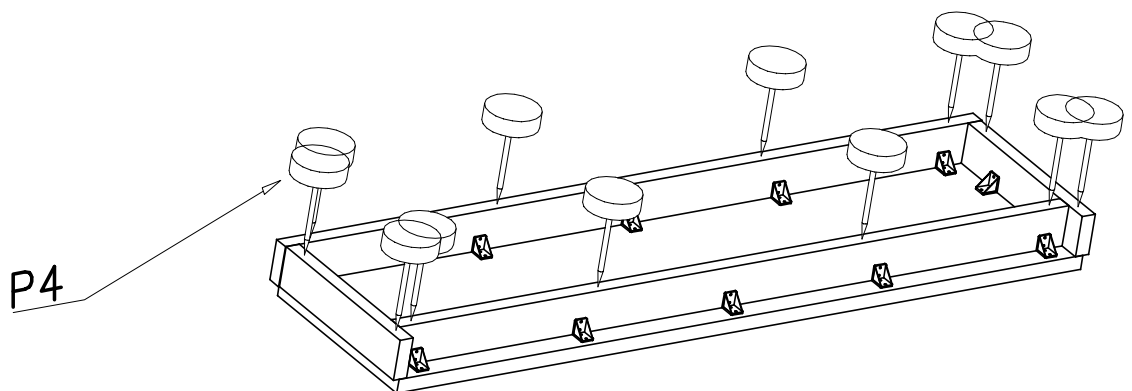
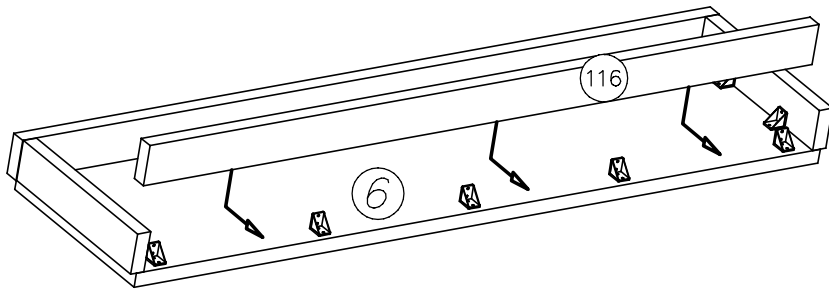
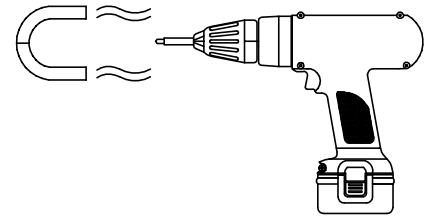
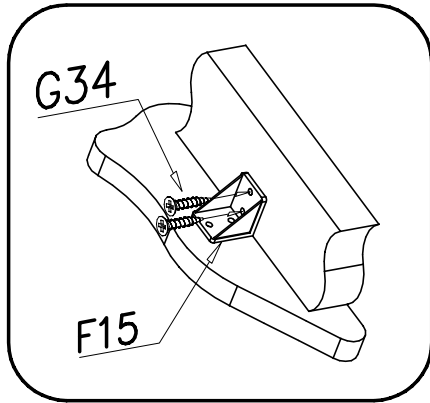
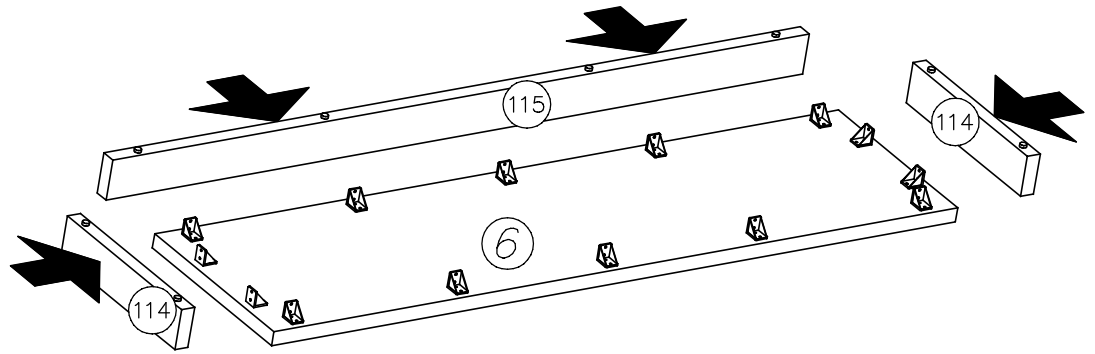



IV

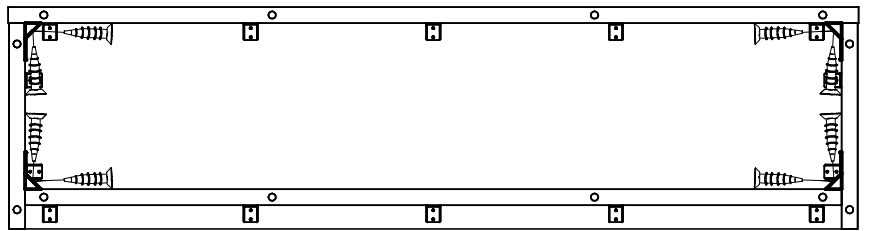
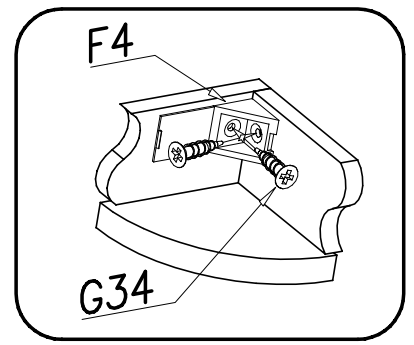
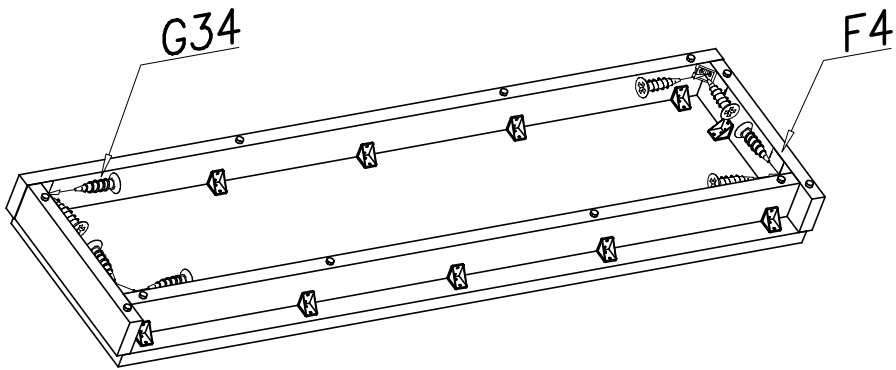

V

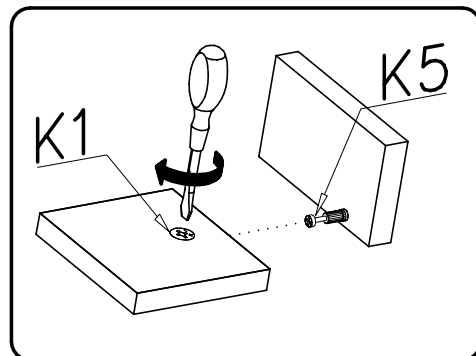
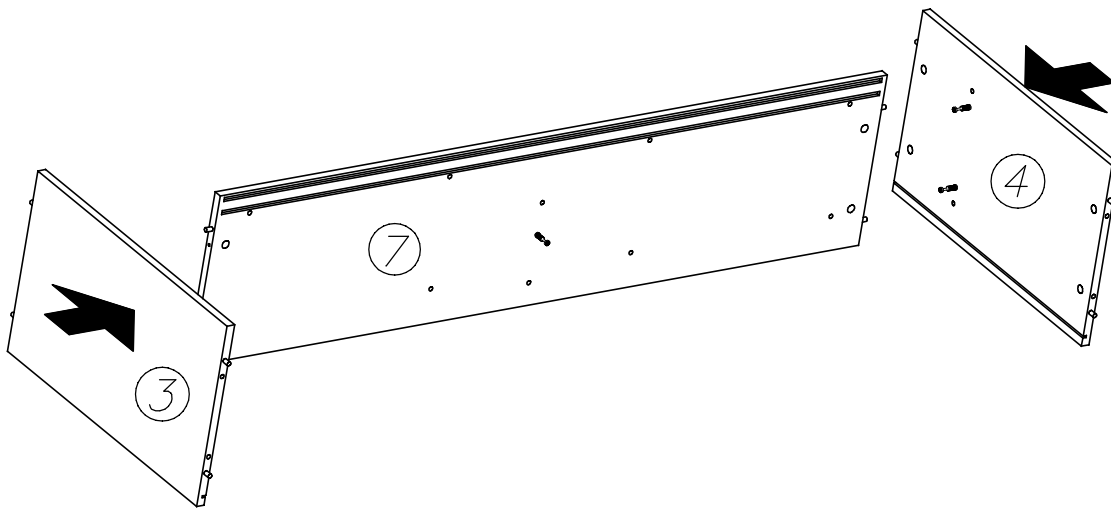



VI

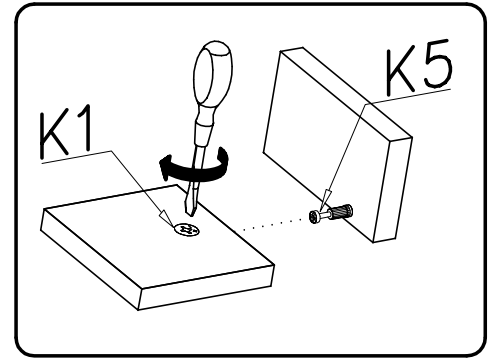
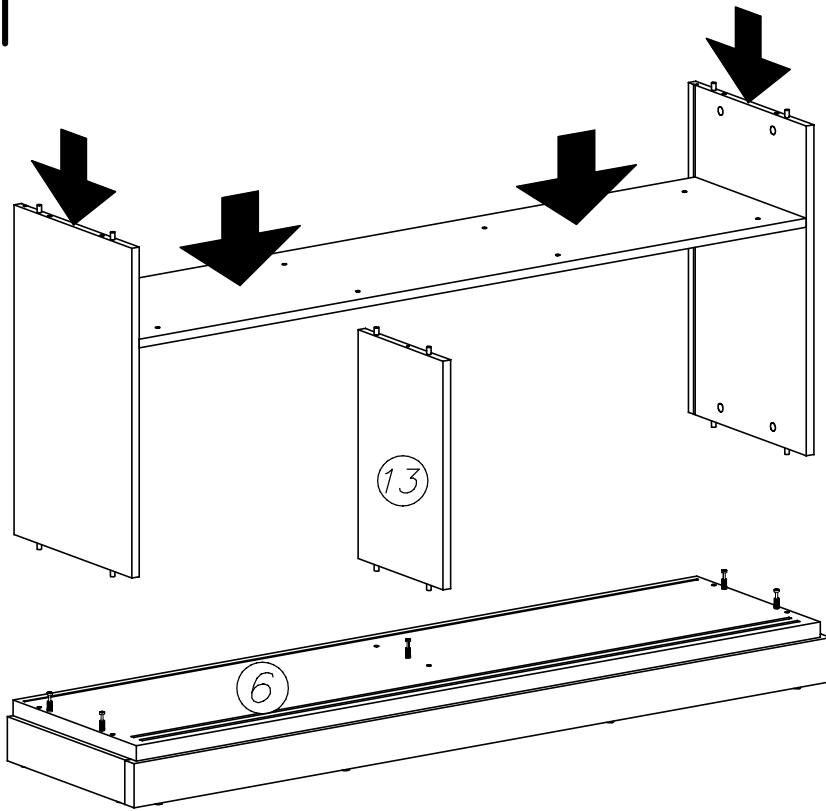

VII

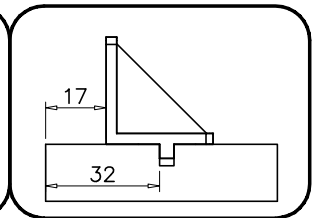
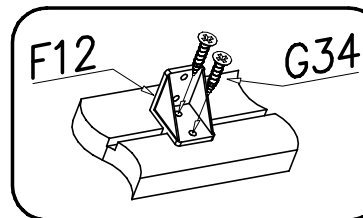
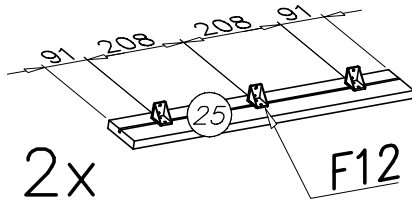

VIII

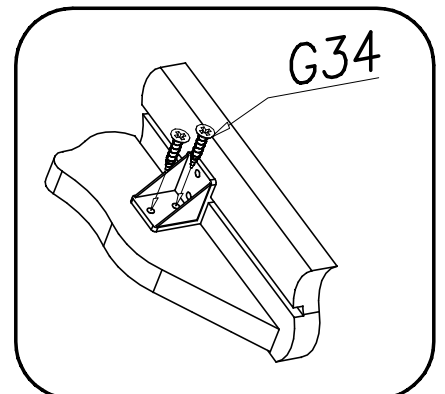
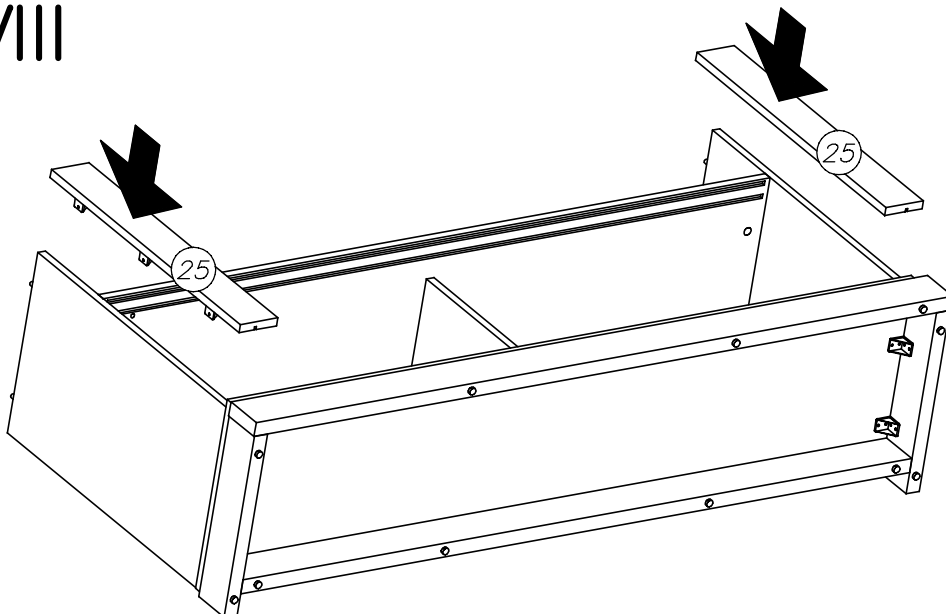



IX

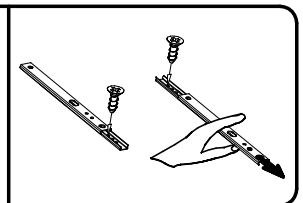
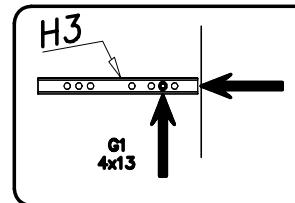
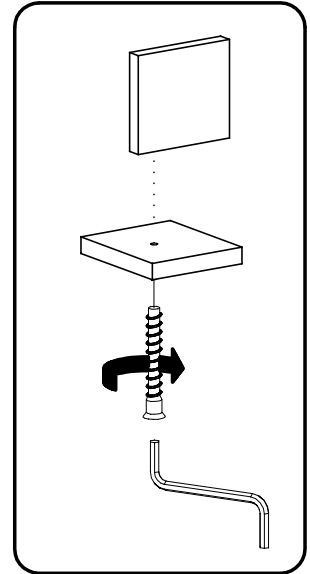
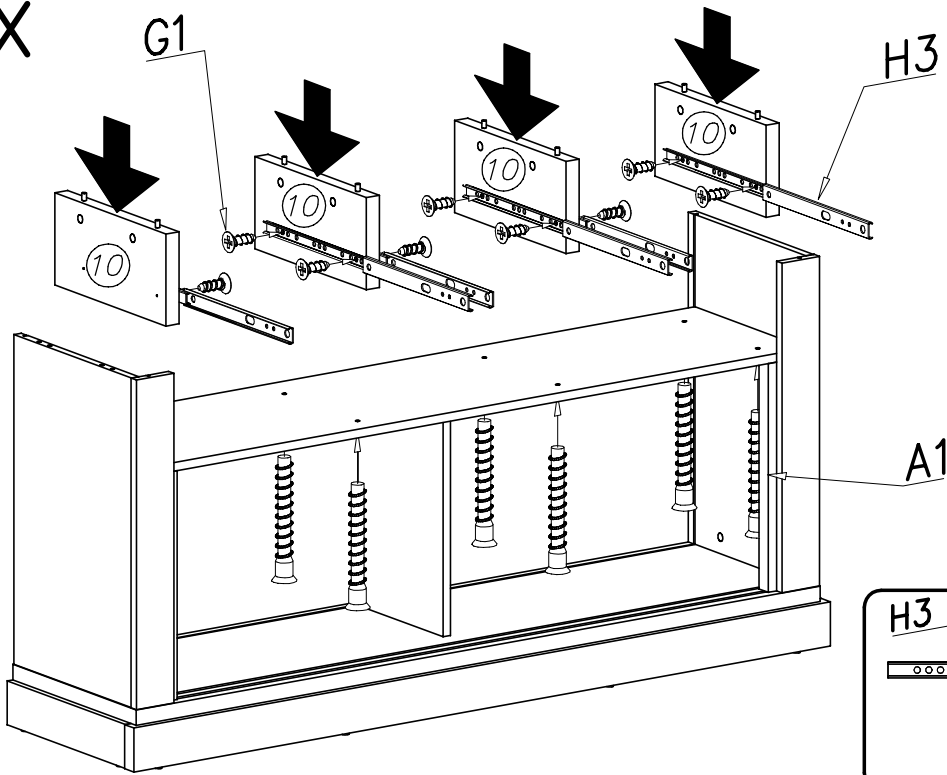

X

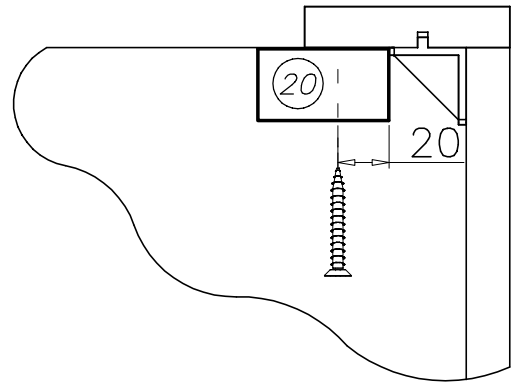
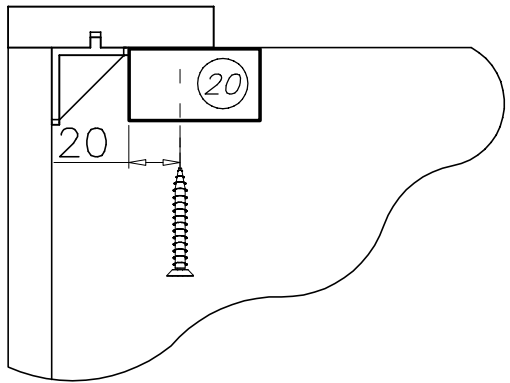
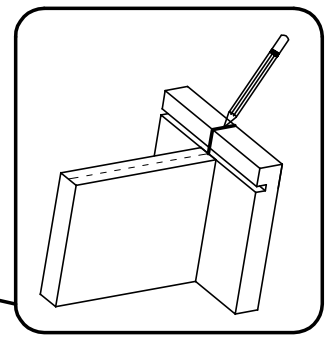
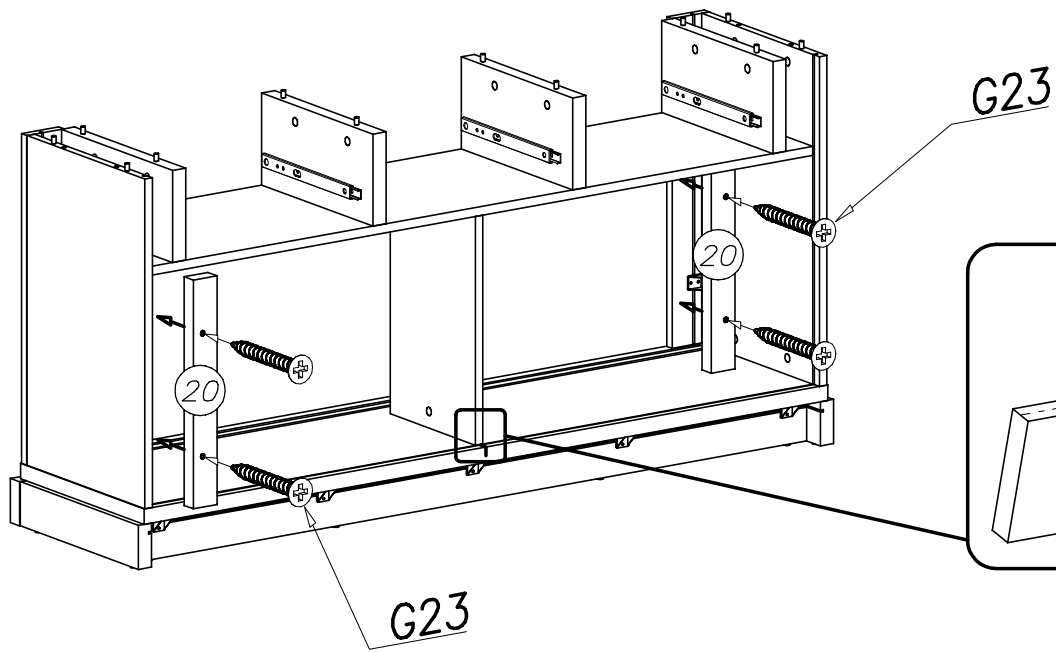



XI

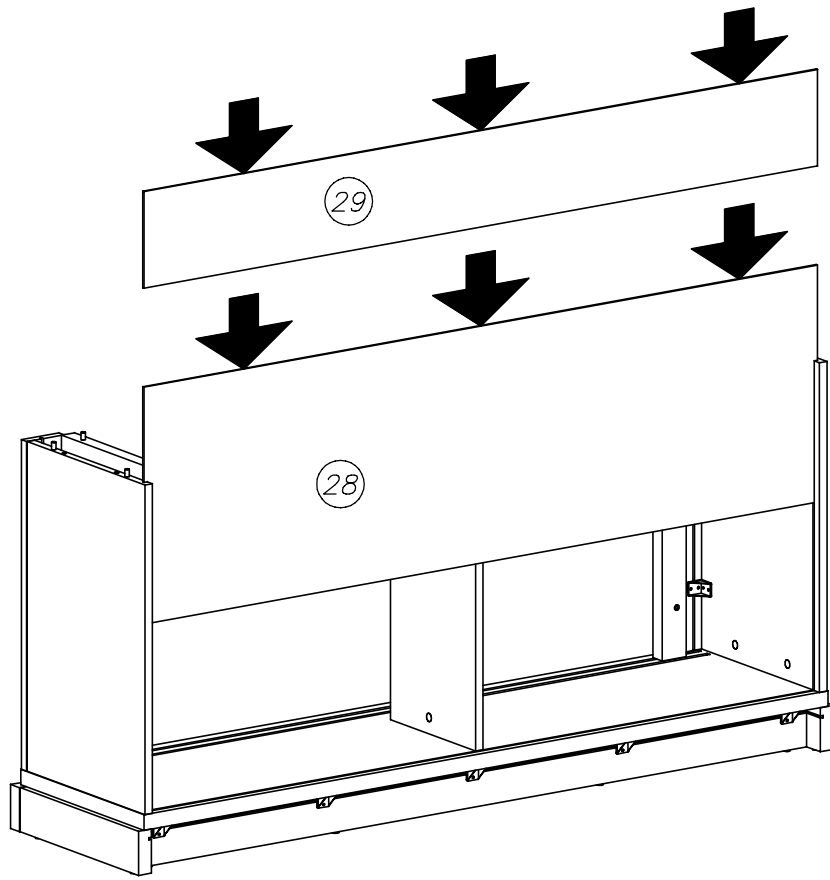

XII

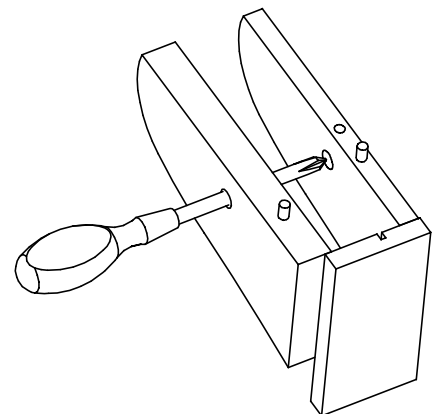
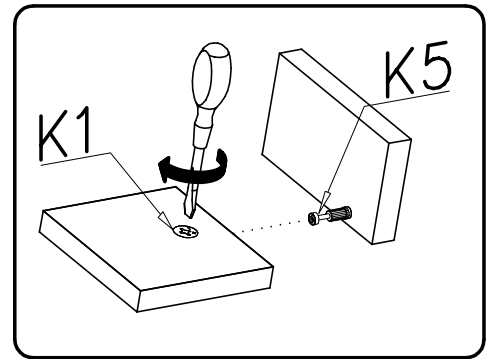
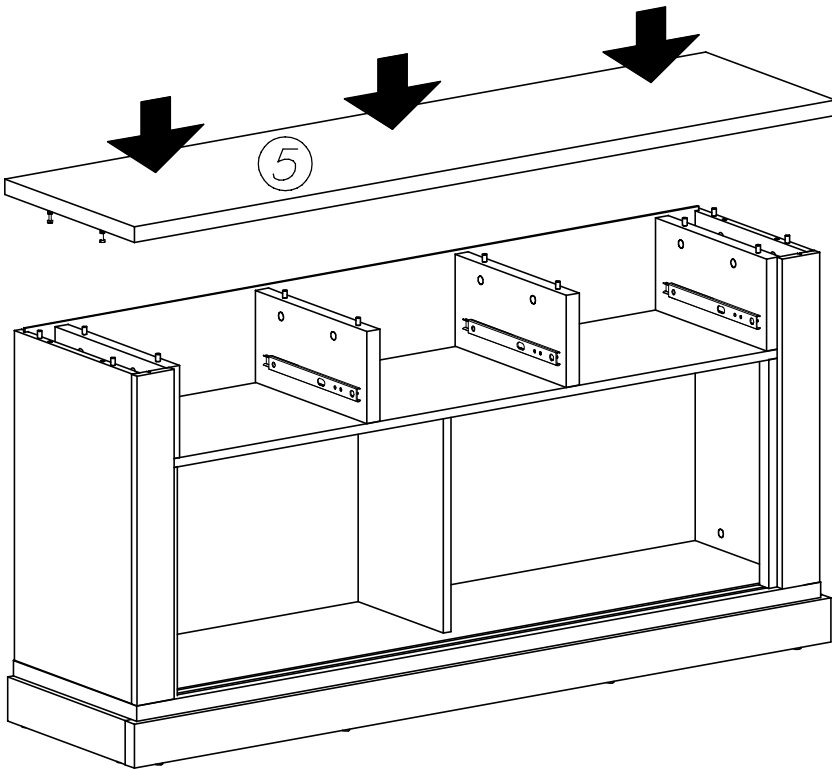



XIII

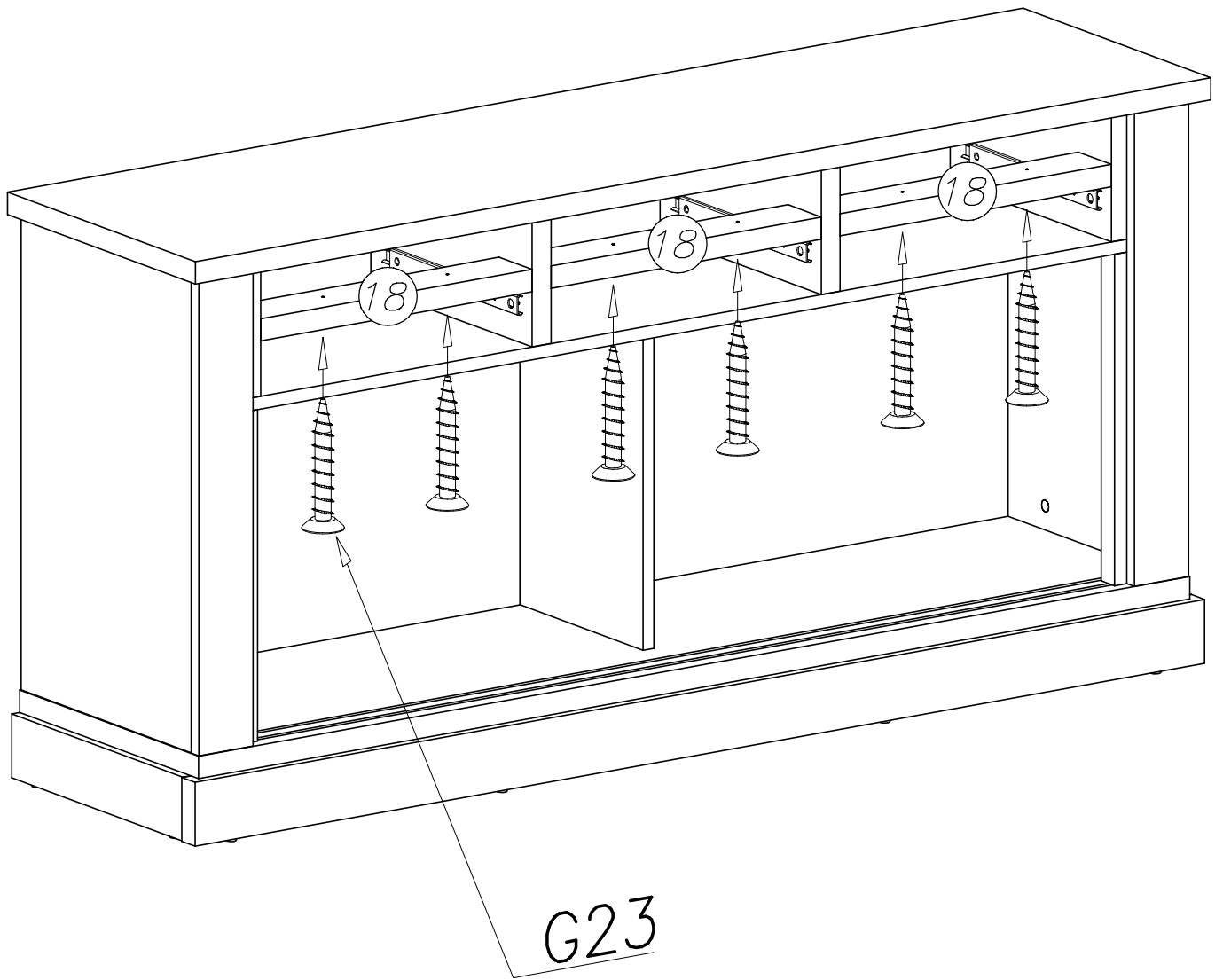



# XIV

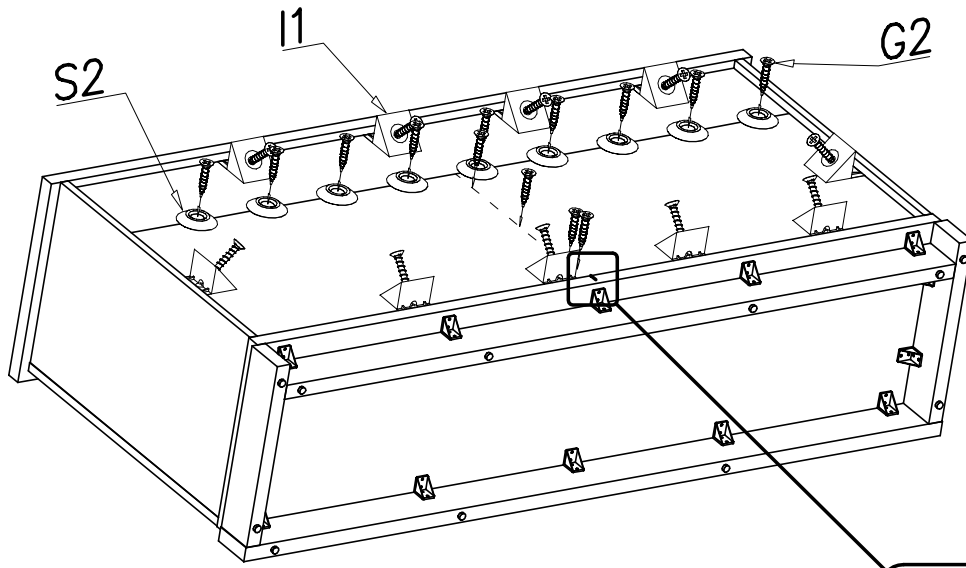

$a = b$

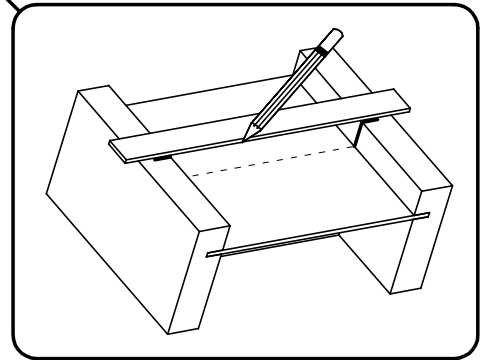
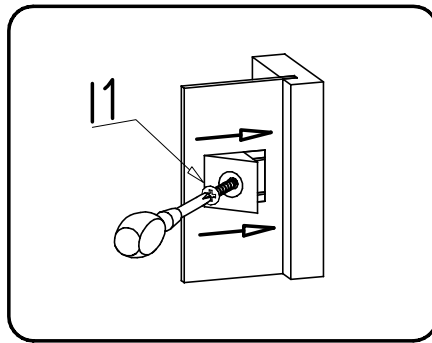
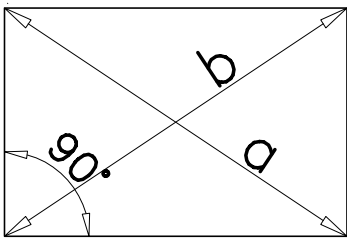

# XV

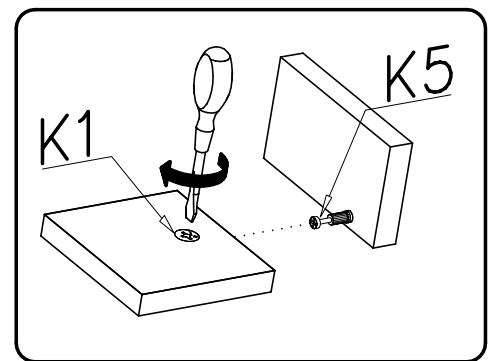
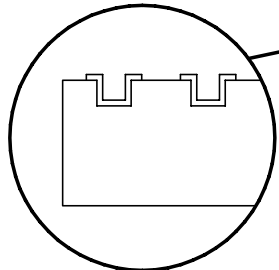
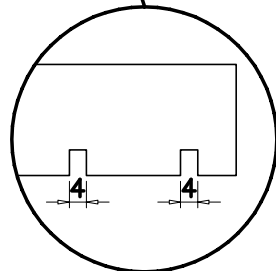
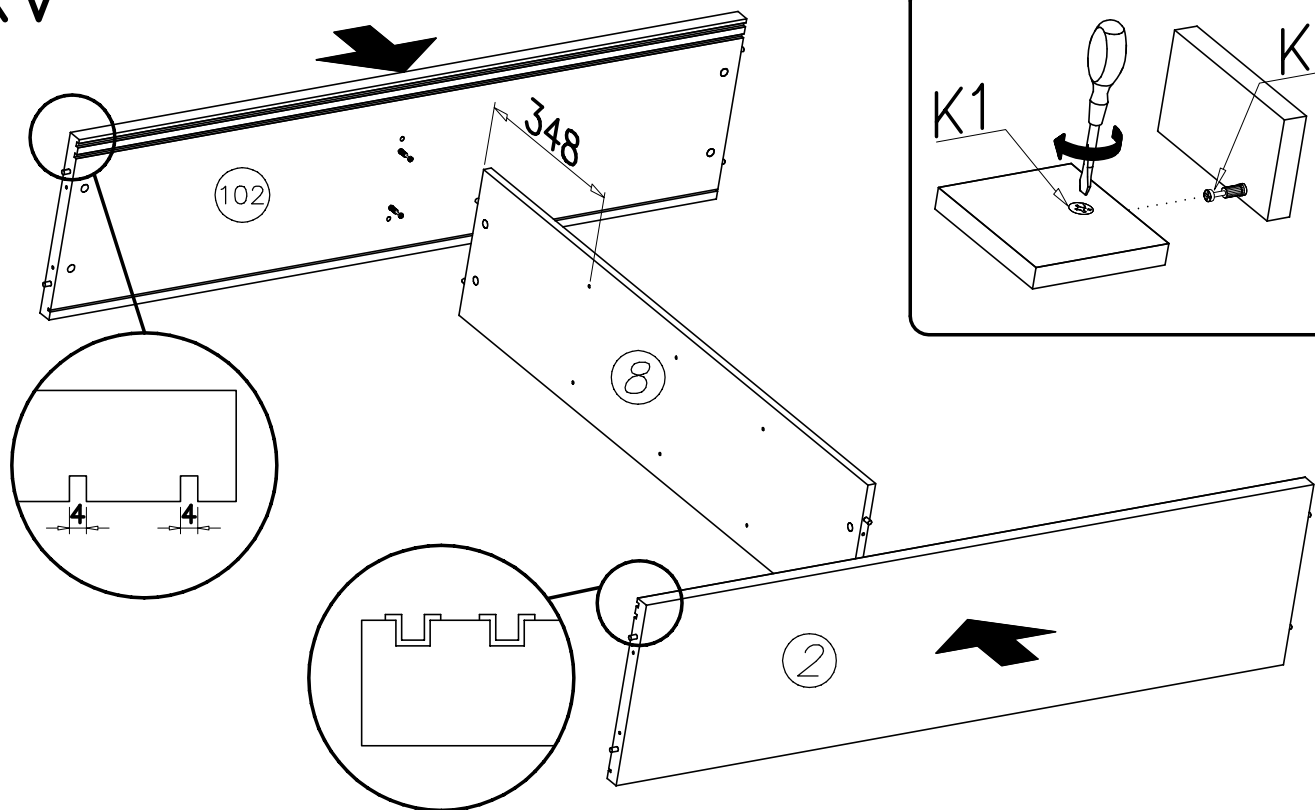



# XVI

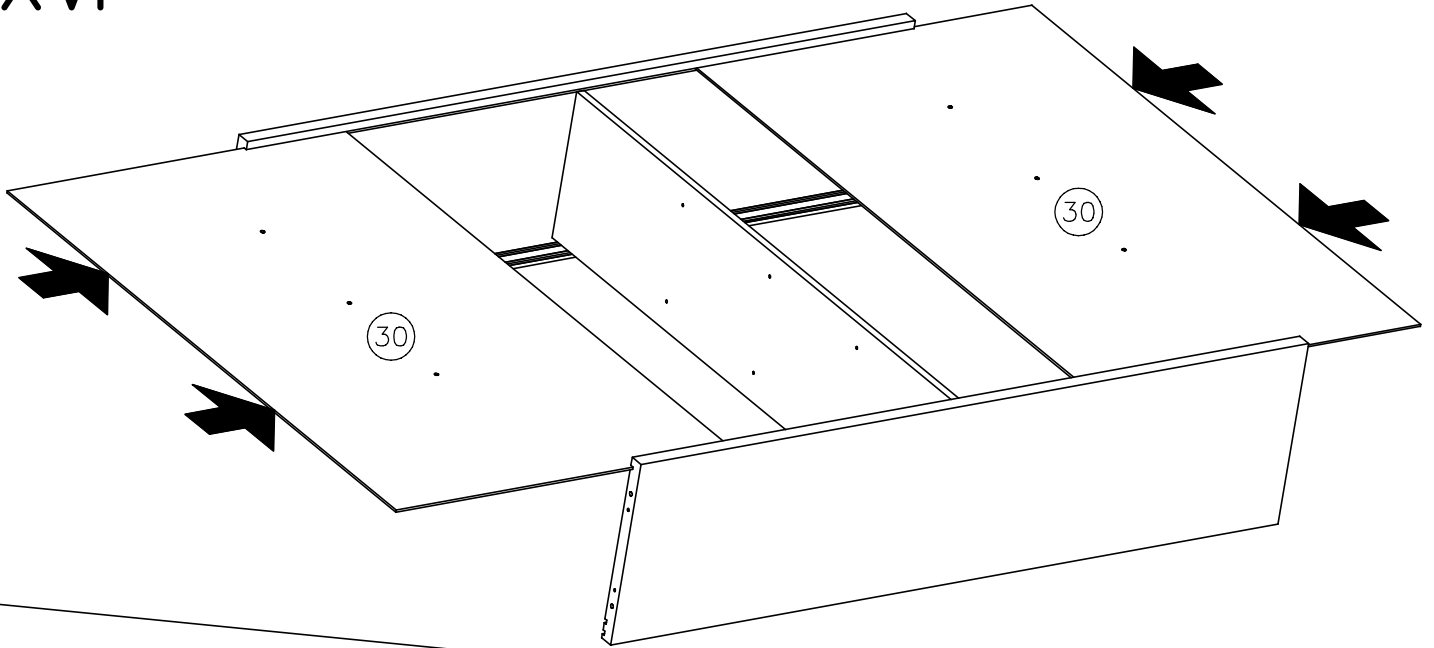

# XVII

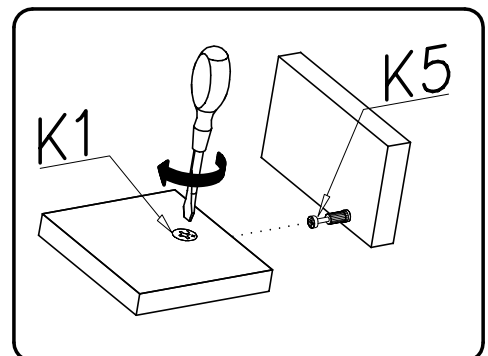
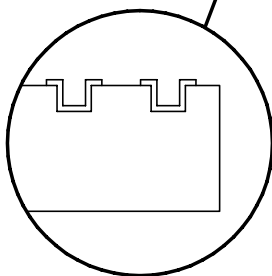
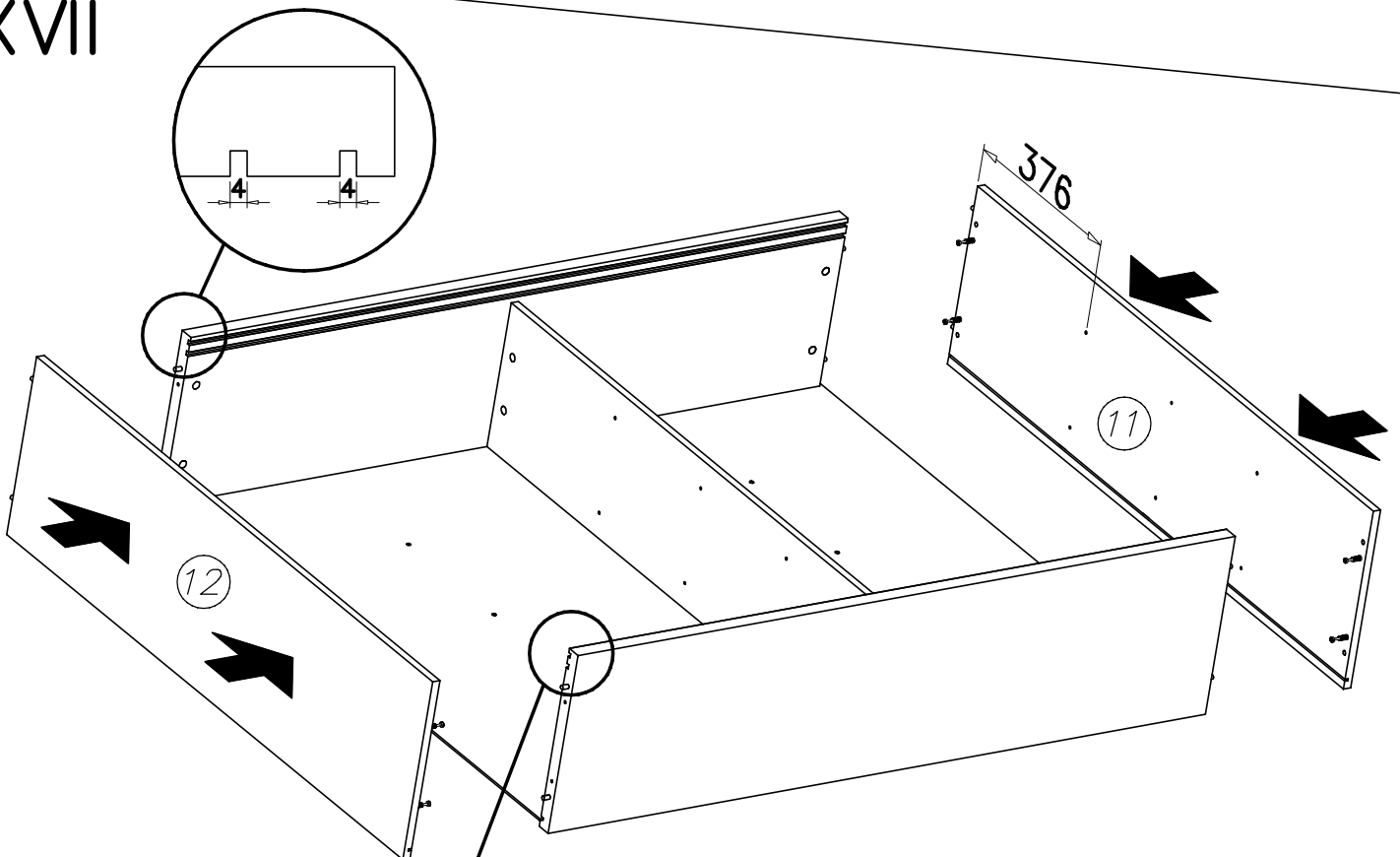



XVIII

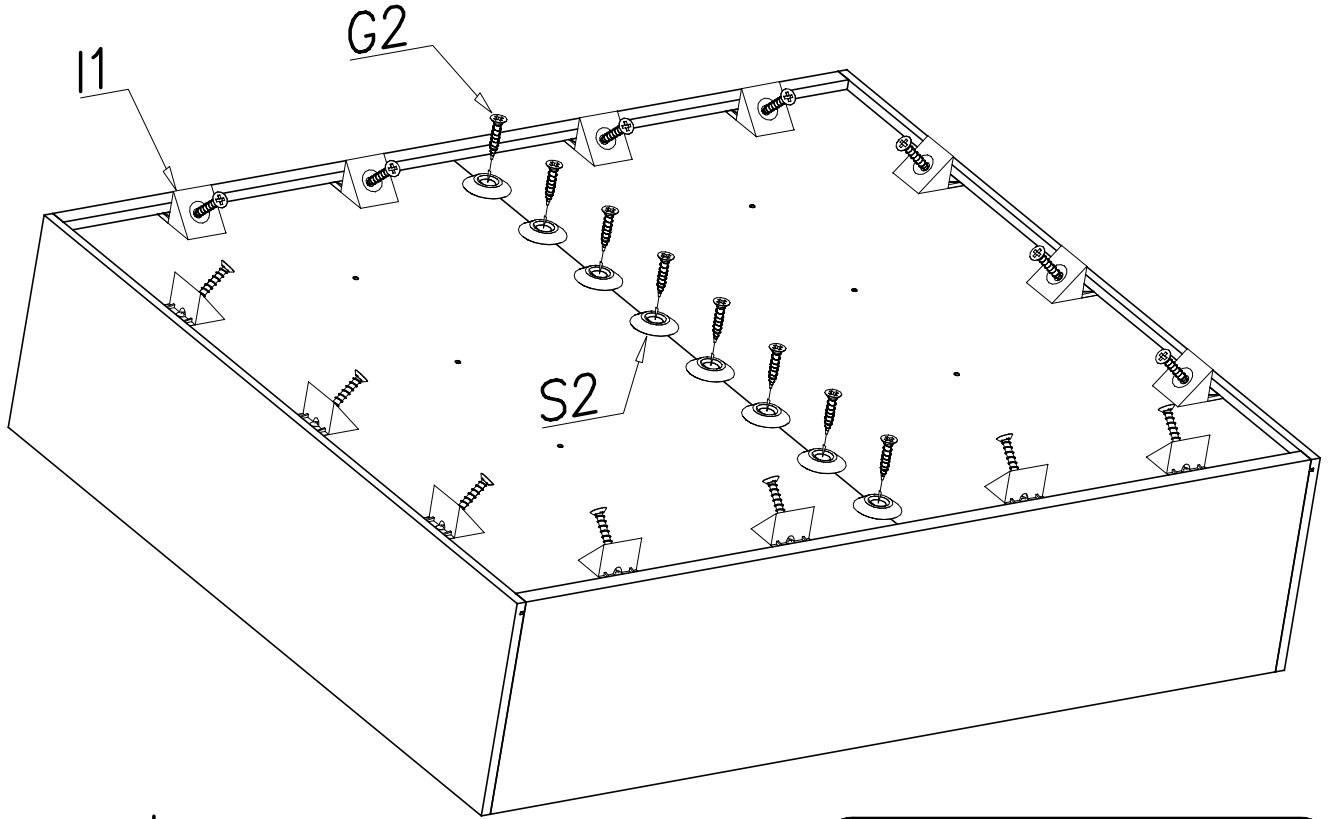

$a = b$

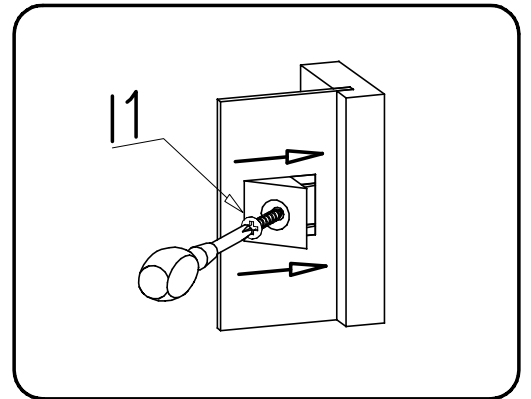
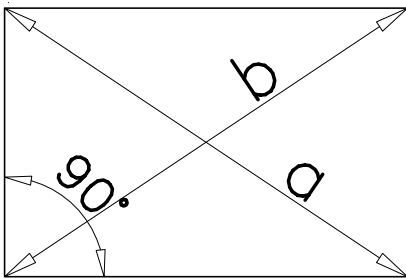

XIX

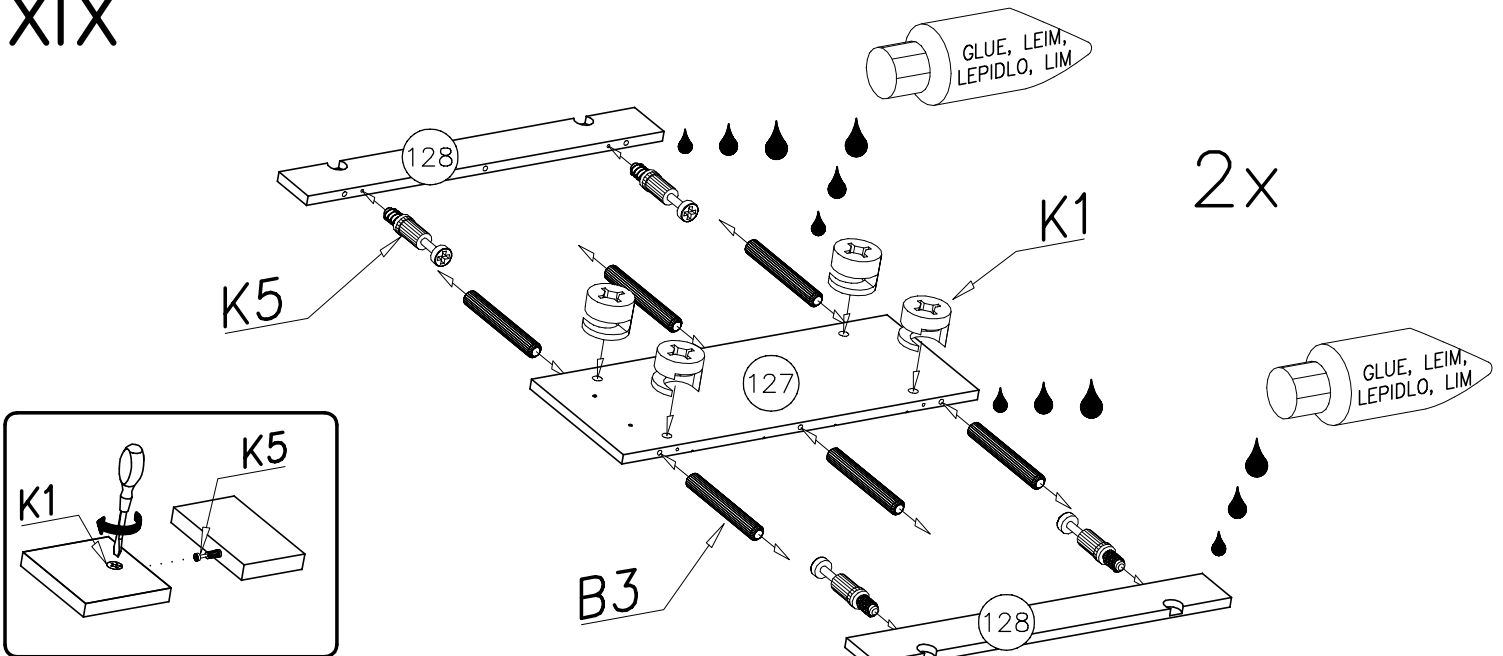

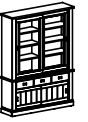

XX

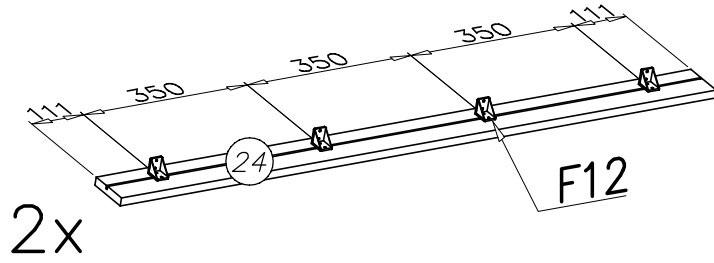

2x

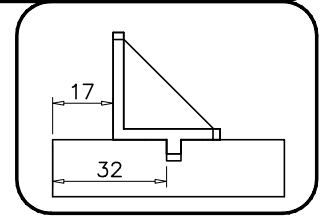
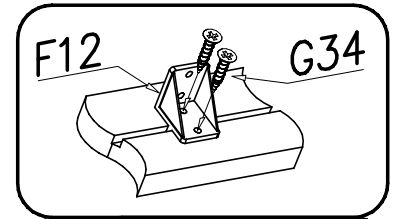

XXI

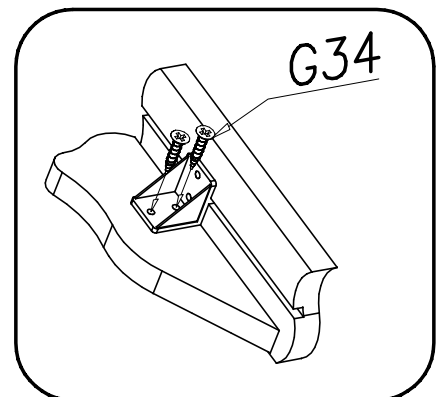
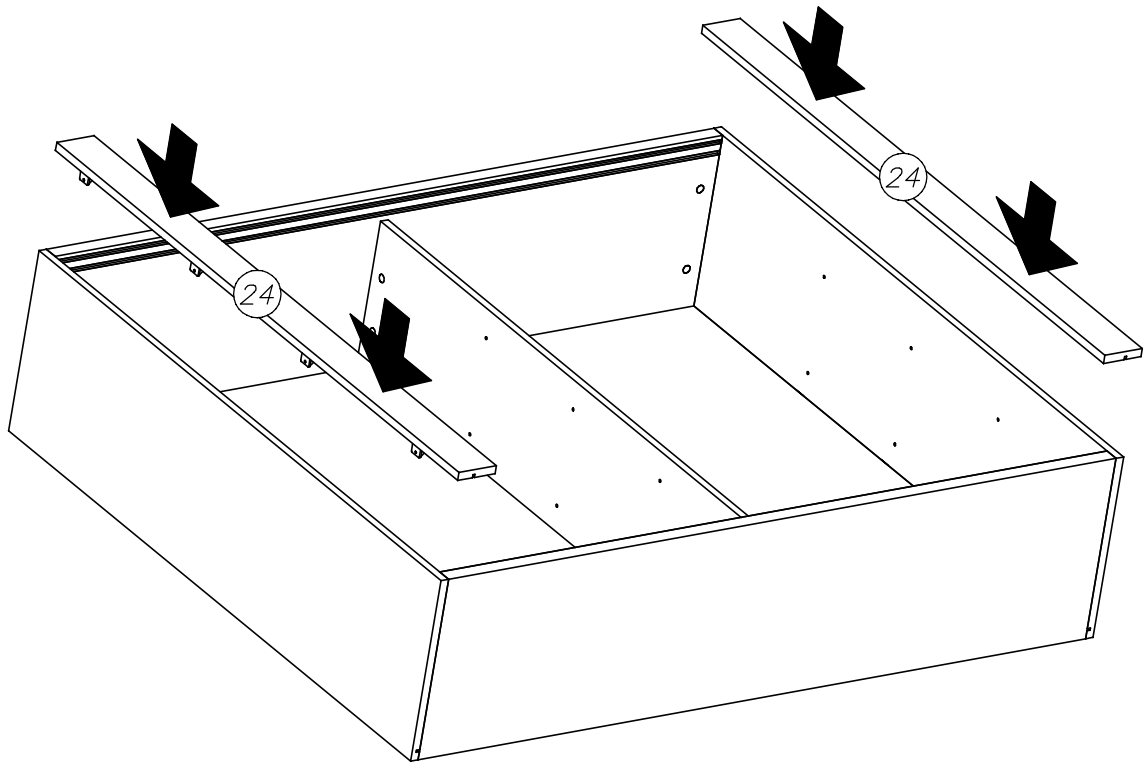



# XXII

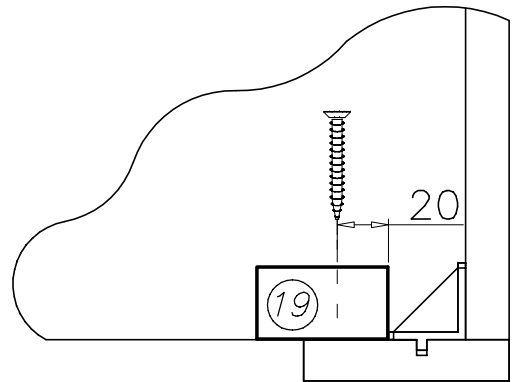
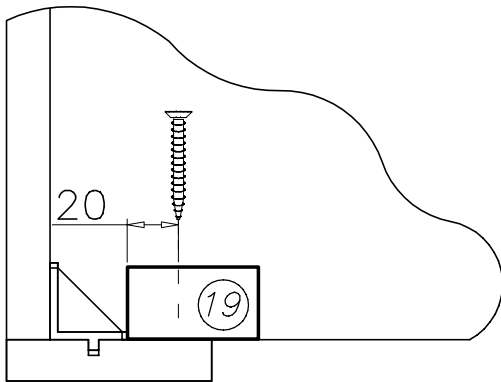
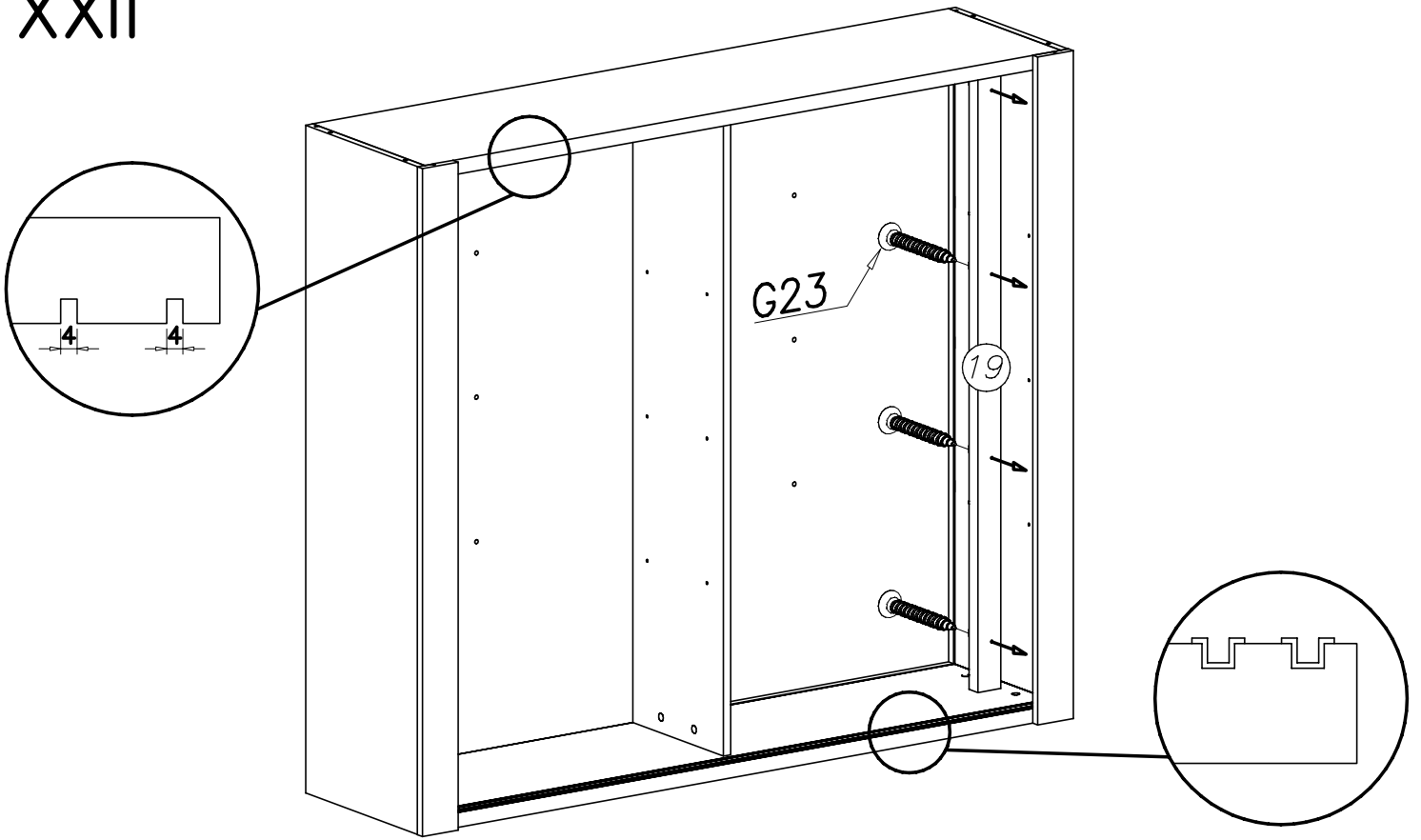

# XXIII

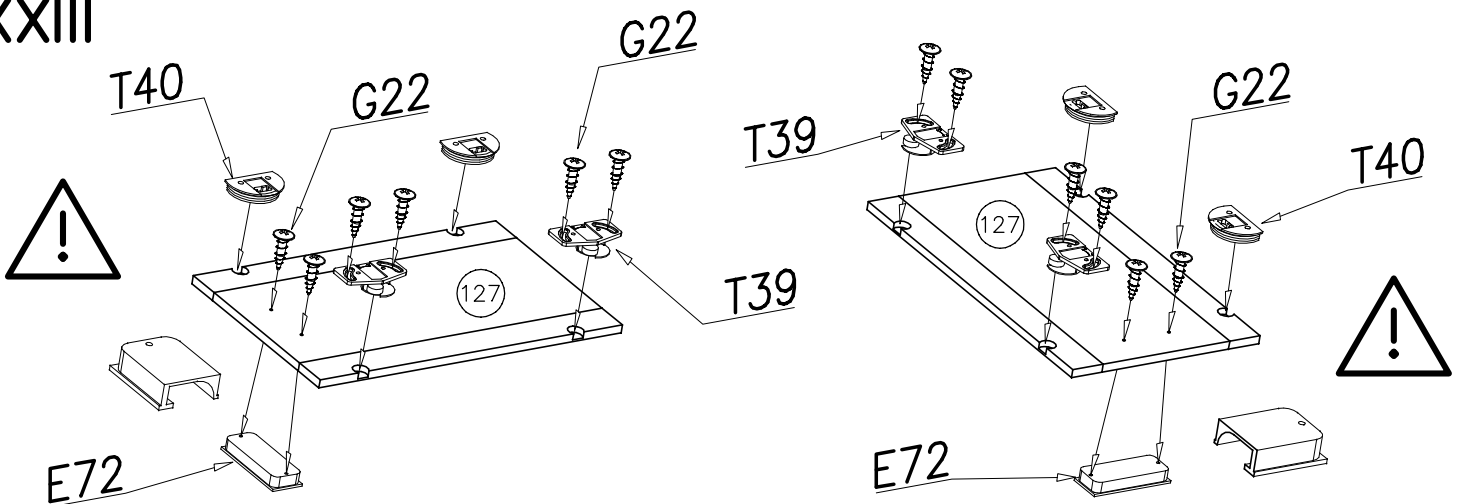



# XXIV

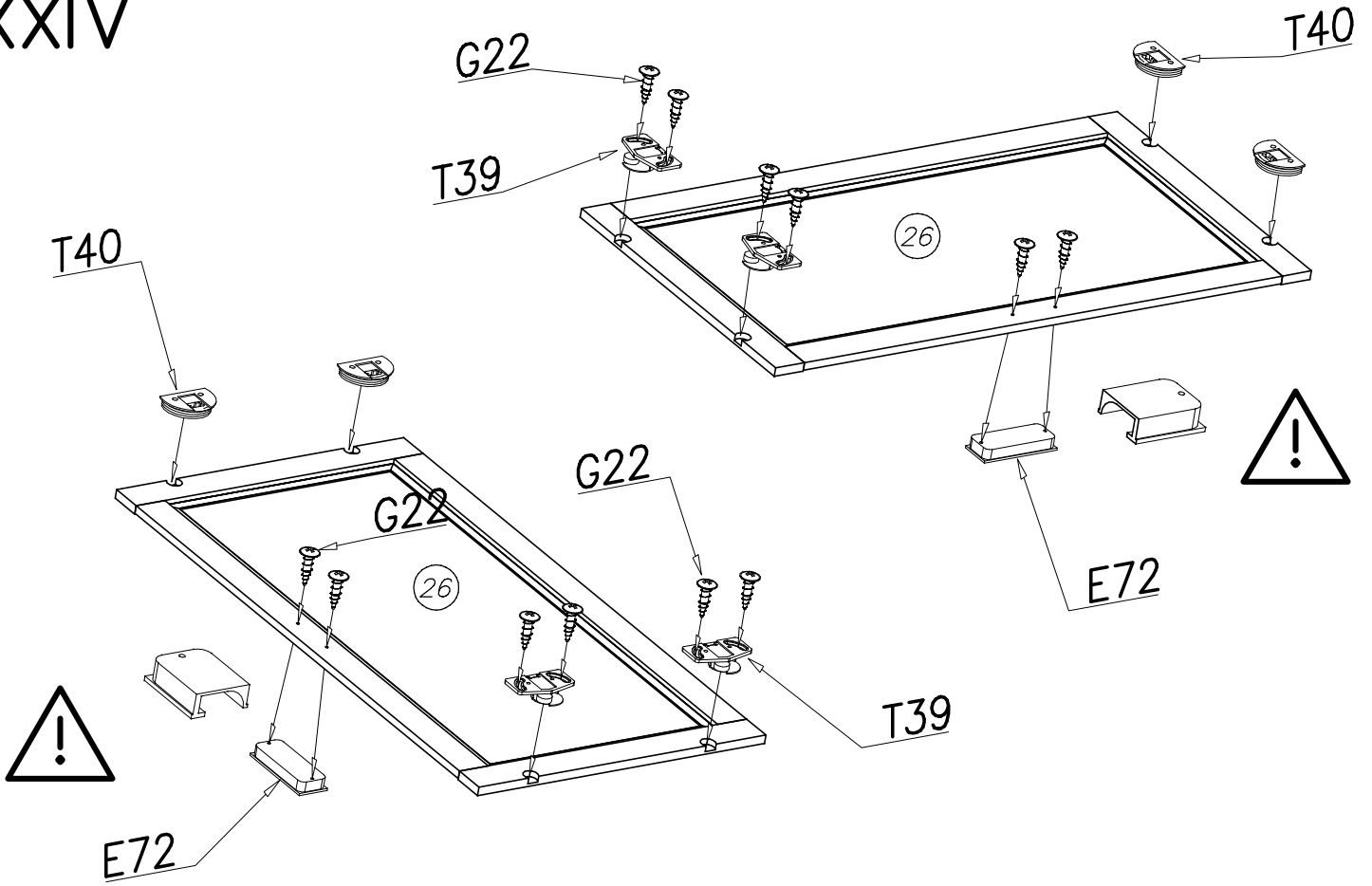

# XXV

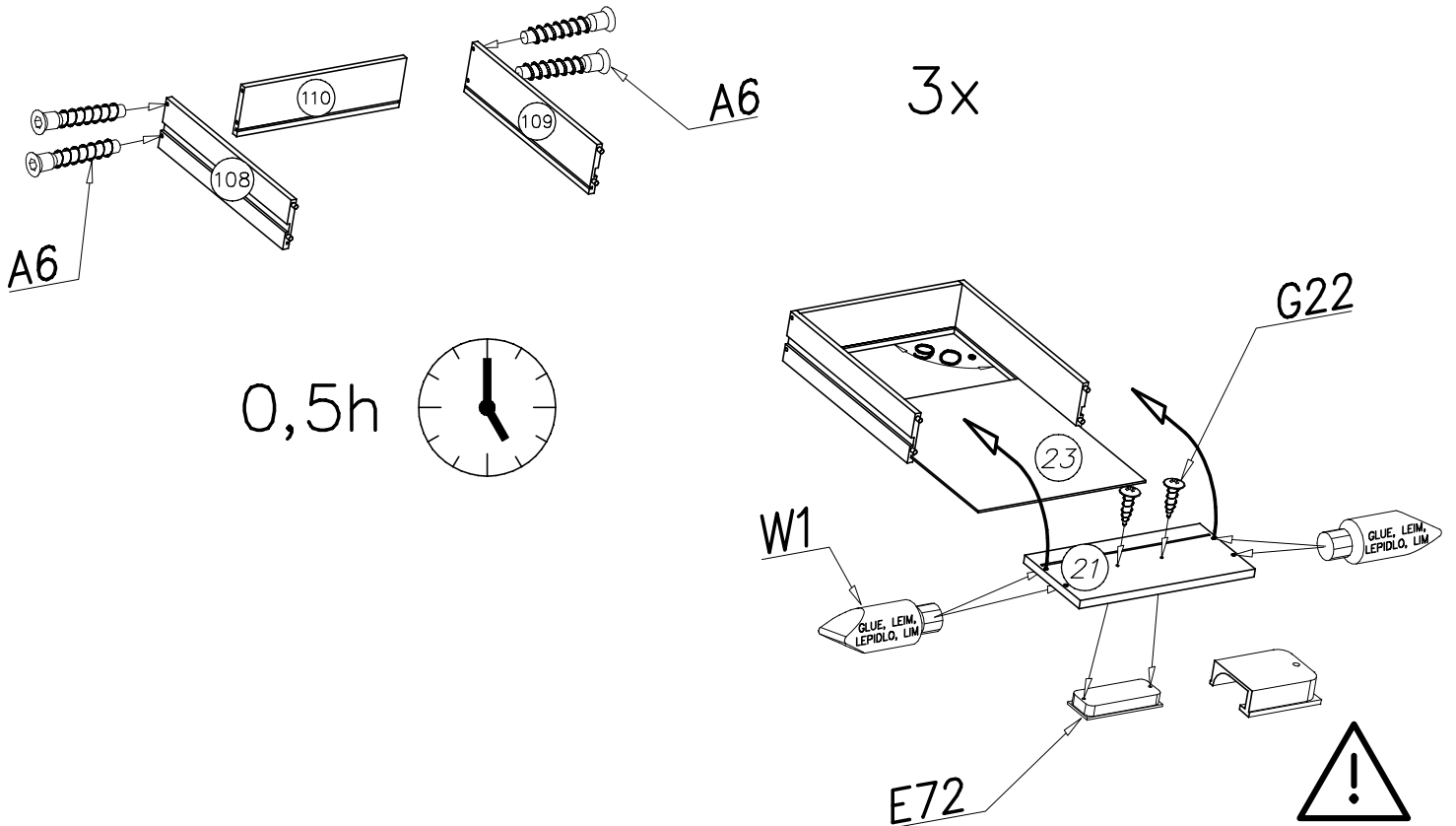



# XXVI

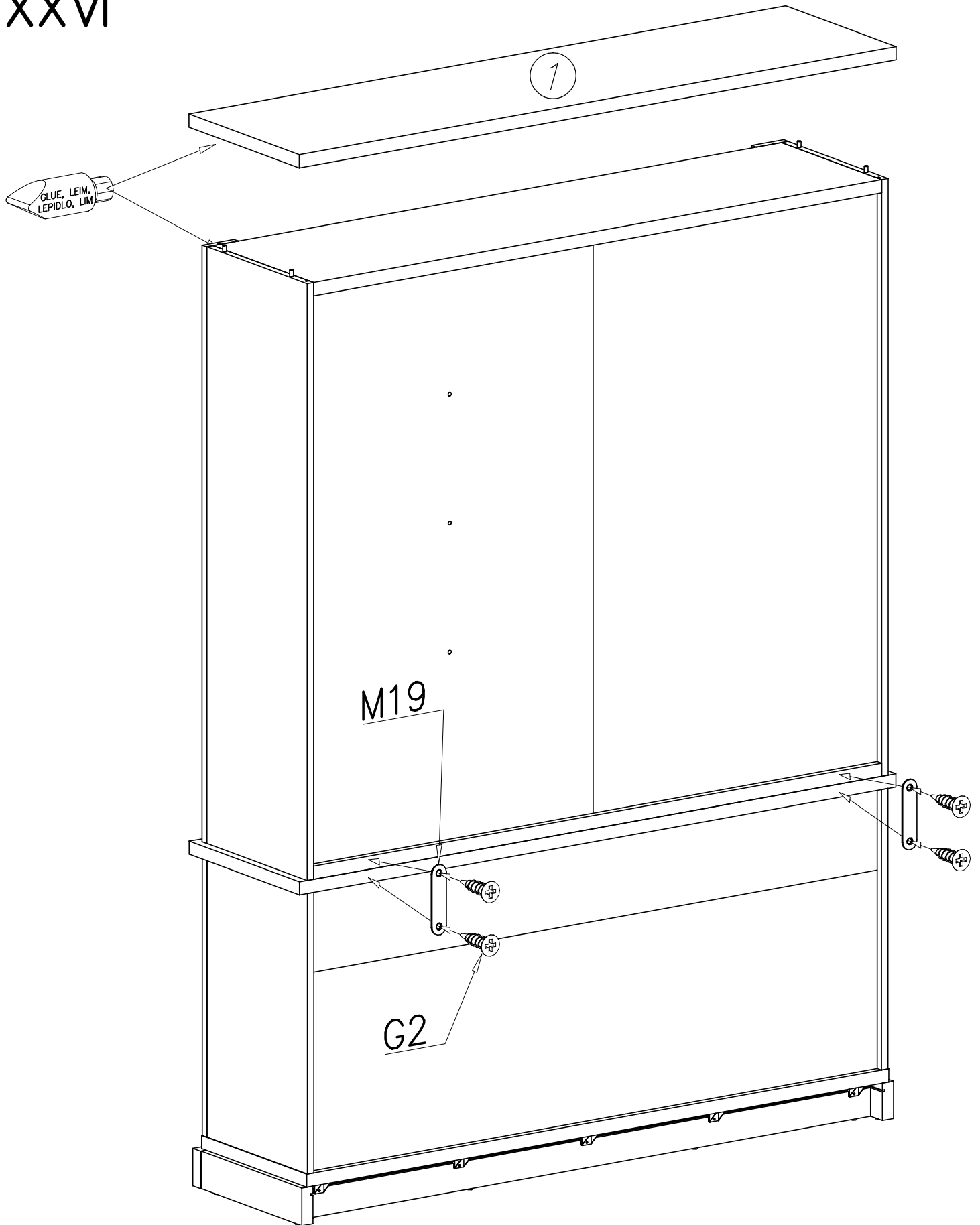



XXVII

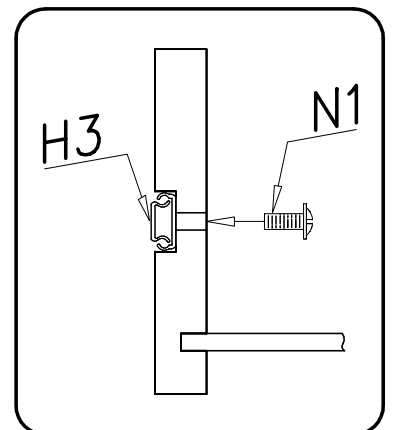
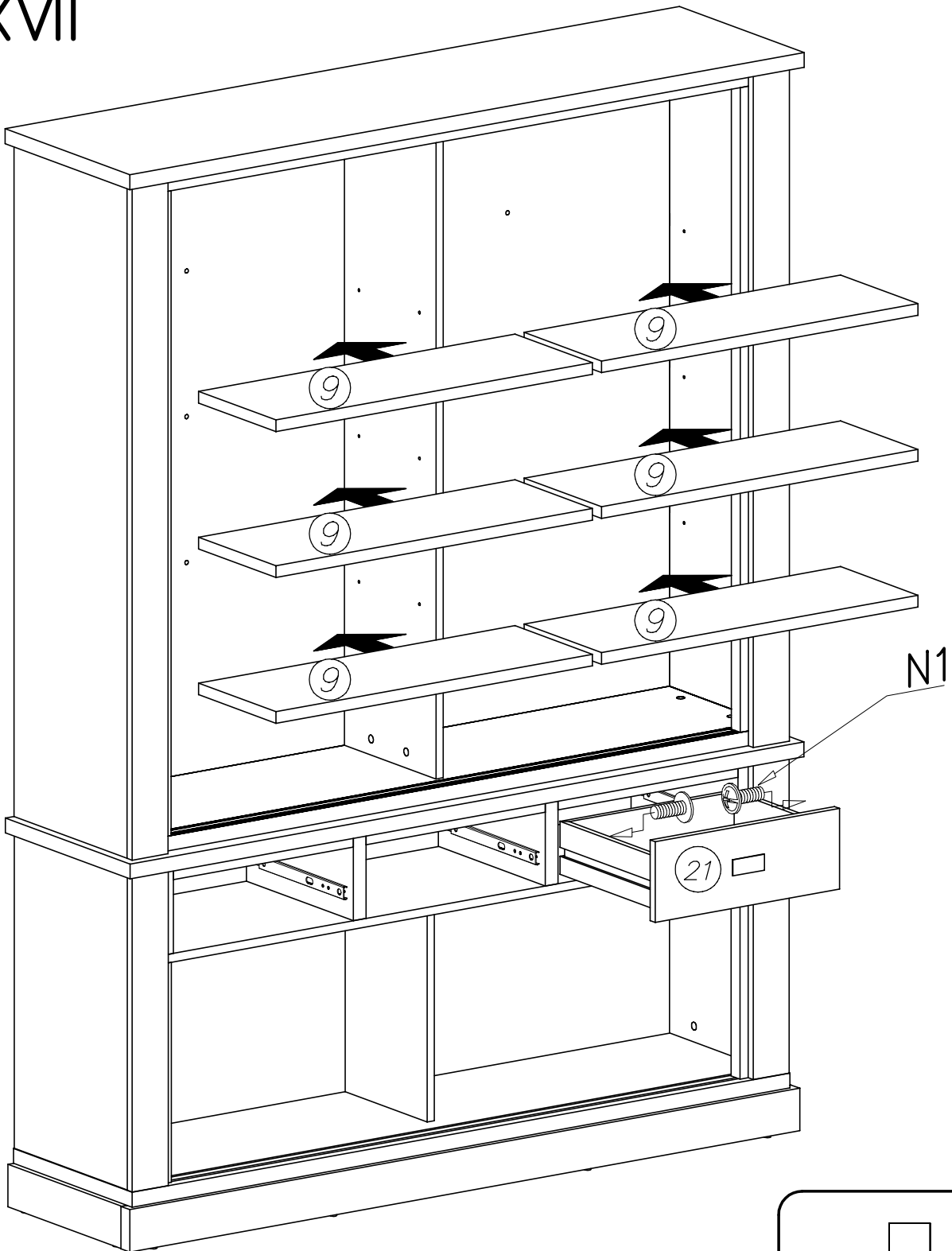



# XXVIII

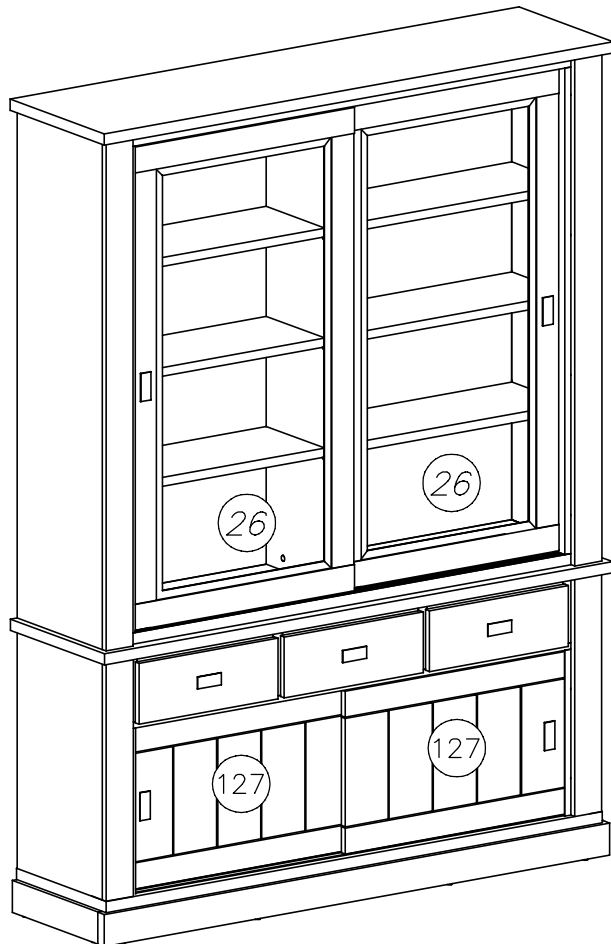
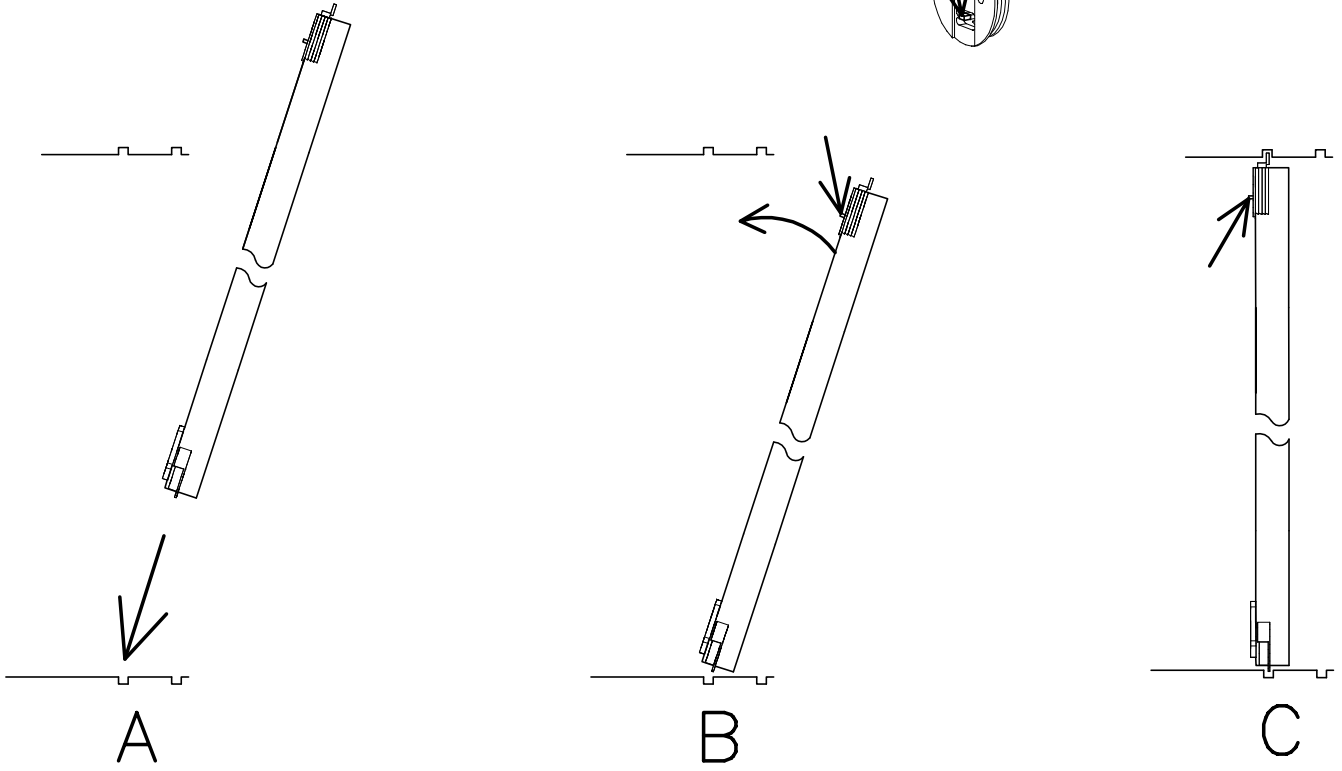
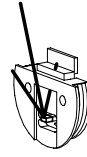



Achtung • Opgelet • Uwaga • Dikkat • Внимание •  
 Attention • Upozorneni • Figyelem • Allenzione • Atentie



|           |  |
|-----------|--|
| <b>D</b>  | Überschreiten Sie die angegebenen Maximalbelastungen nicht. Andernfalls kann das Möbelstück beschädigt oder zerstört werden.               |
| <b>GB</b> | Do not exceed the maximum loads specified. Otherwise, the furniture may sustain damage or be irreparably damaged.                          |
| <b>NL</b> | Overschrijd de aangegeven maximale belastingen niet. Anders kan het meubelstuk worden beschadigd of vernield.                              |
| <b>PL</b> | Nie wolno przekraczać podanych maksymalnych wartości obciążenia. W innym przypadku można mebel uszkodzić lub zniszczyć.                    |
| <b>TR</b> | Belirtilen azami yuk degerini asmayiniz, aksi taktirde mobilya parcasi zarar gorebilir veya kullanilamaz hale gelebilir.                   |
| <b>RU</b> | Не допускается превышение указанных максимальных нагрузок. В противном случае возможно повреждение или разрушение мебели.                  |
| <b>FR</b> | Ne dépassez pas les charges maximum indiquées. Sinon, le meuble peut être endommagé ou détruit.  |
| <b>CZ</b> | Nepřekračujte uvedená maximální zatížení. V opačném případě může dojít k poškození nebo zničení nábytku.                                   |
| <b>HU</b> | Tartsa be az engedélyezett maximális terhelhetőséget/teljesítményt. Különben a bútor és annak alkatrészei megsérülhetnek, tönkre mehetnek. |
| <b>IT</b> | Non superare il carico massimo indicato. Altrimenti il mobile rischia di rovinarsi o frantumarsi.  |
| <b>RO</b> | Nu depasiti sollicitarile maxime specificate. Altfel puteti sa deteriorati sau sa distrugeti piesa de mobilier.                            |
| <b>SK</b> | Neprekročte uvedené maximálne zaťaženia. V opačnom prípade sa môže nábytok poškodiť alebo zničiť.  |