

Assembly Instruction

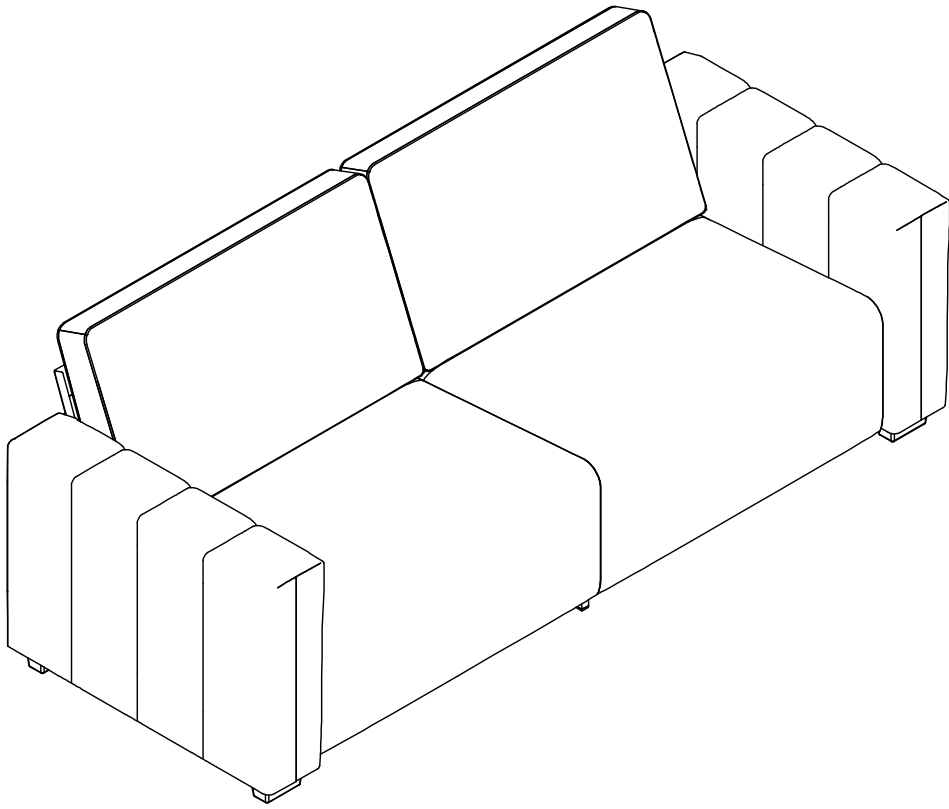

PARTS

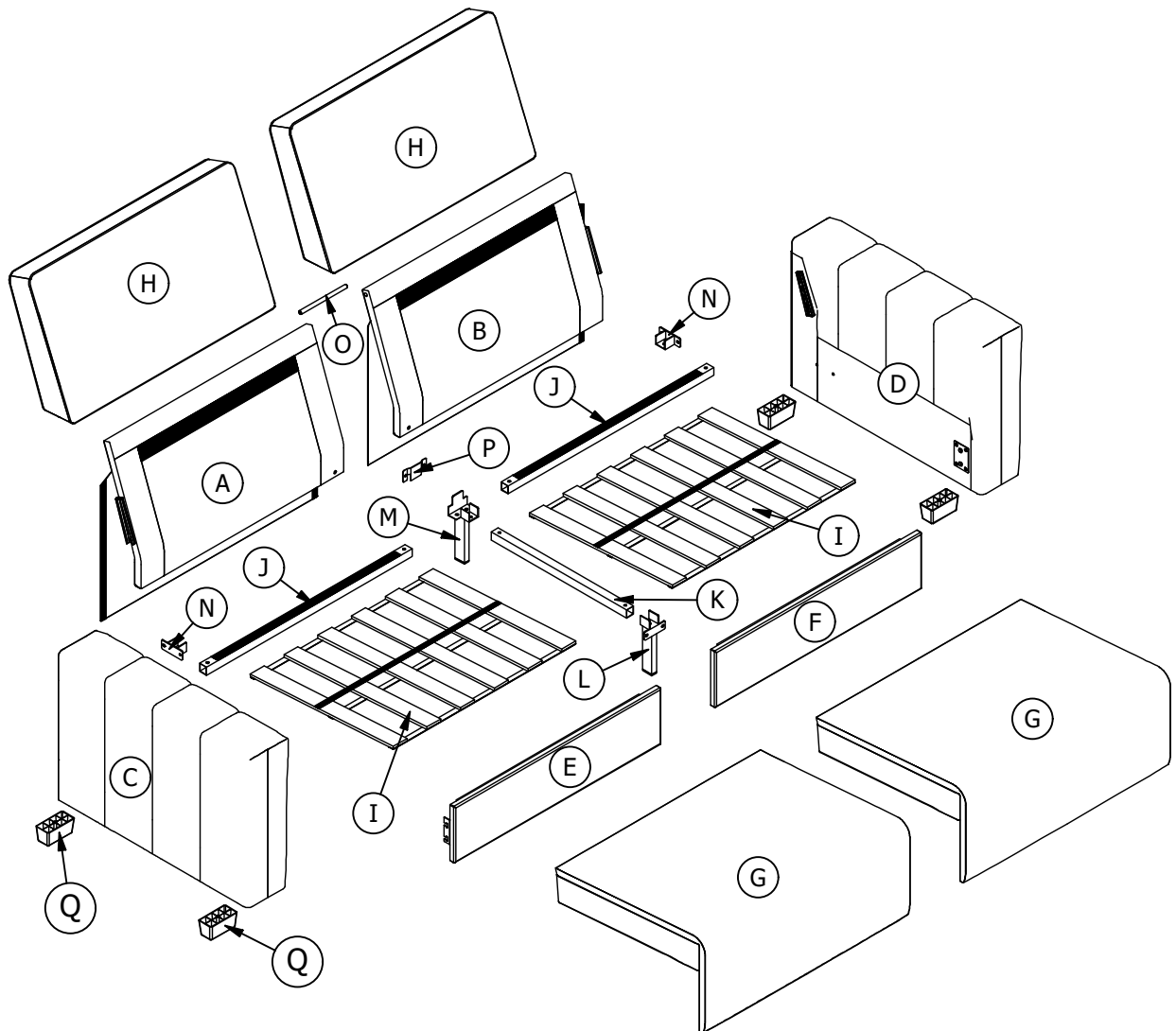

PARTS LIST

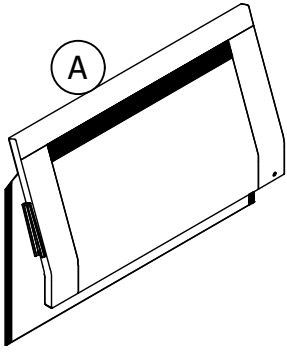

A
Left Back Frame
X 1 PC

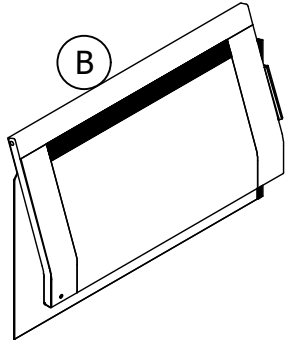

B
Right Back Frame
X 1 PC

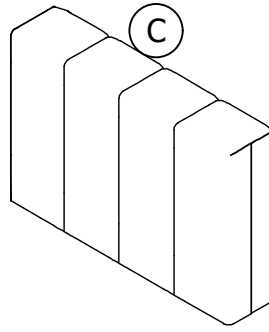

C
Left Armrest
X 1 PC

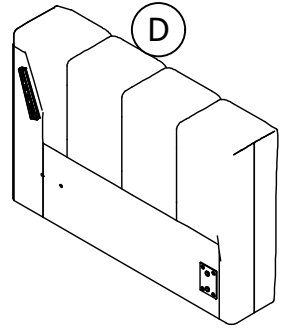

D
Right Armrest
X 1 PC

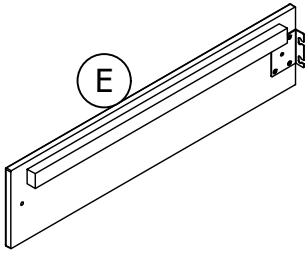

E
Left Front Rail
X 1 PC

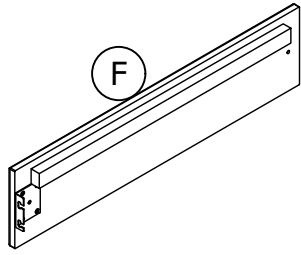

F
Right Front Rail
X 1 PC

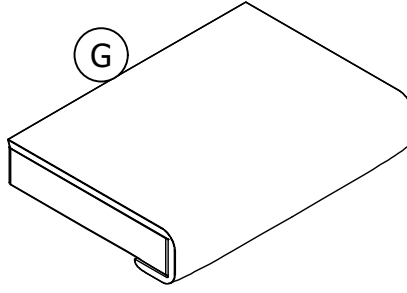

G
Seat Cushion
X 2 PCS

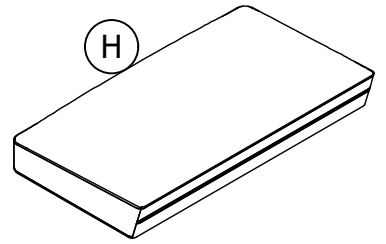

H
Back Cushion
X 2 PCS

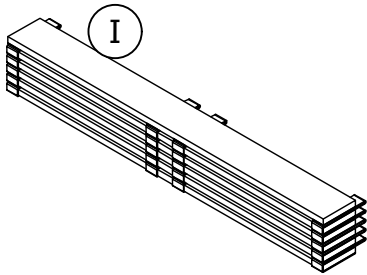

I
Seat Panel
X 2 PCS

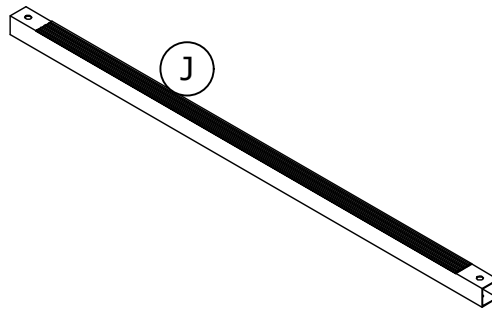

J
Rear Rail
X 2 PCS

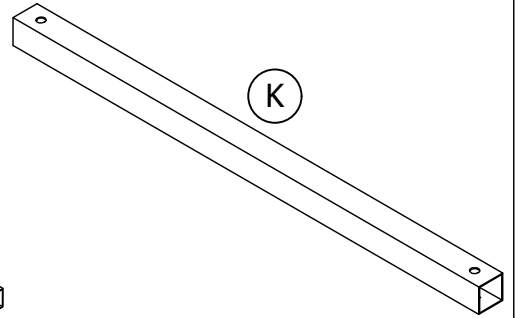

K
Middle Connector
X 1 PC

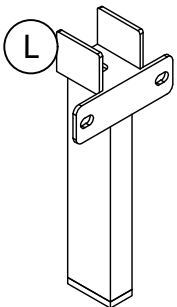

L
Front Middle Leg
X 1 PC

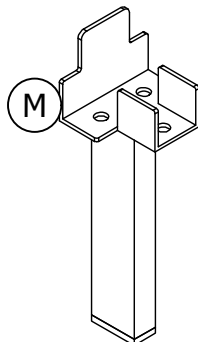

M
Rear Middle Leg
X 1 PC

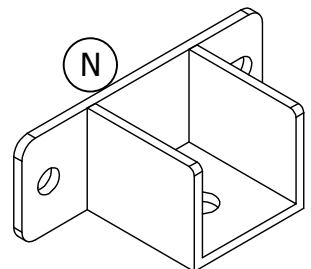

N
Bracket
X 2 PCS

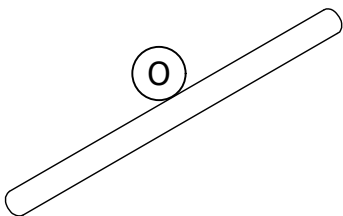

O
Connector
X 1 PC

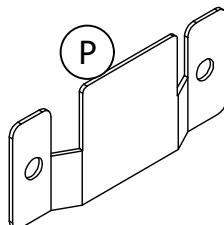

P
Plug-in
X 1 PC

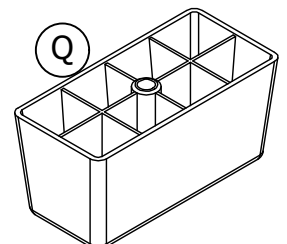

Q
Leg
X 4 PCS

HARDWARE

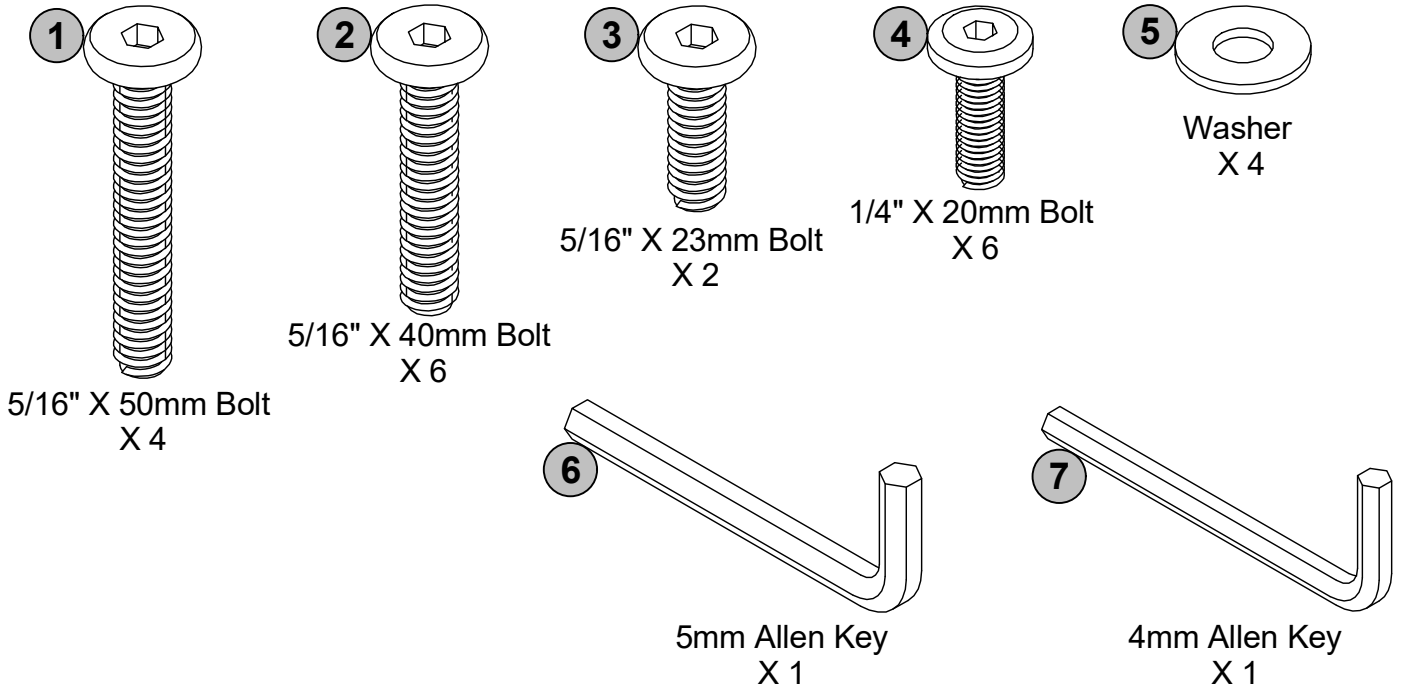

STEP 1:

Some parts will be found in the compartment under the Armrests, as shown.

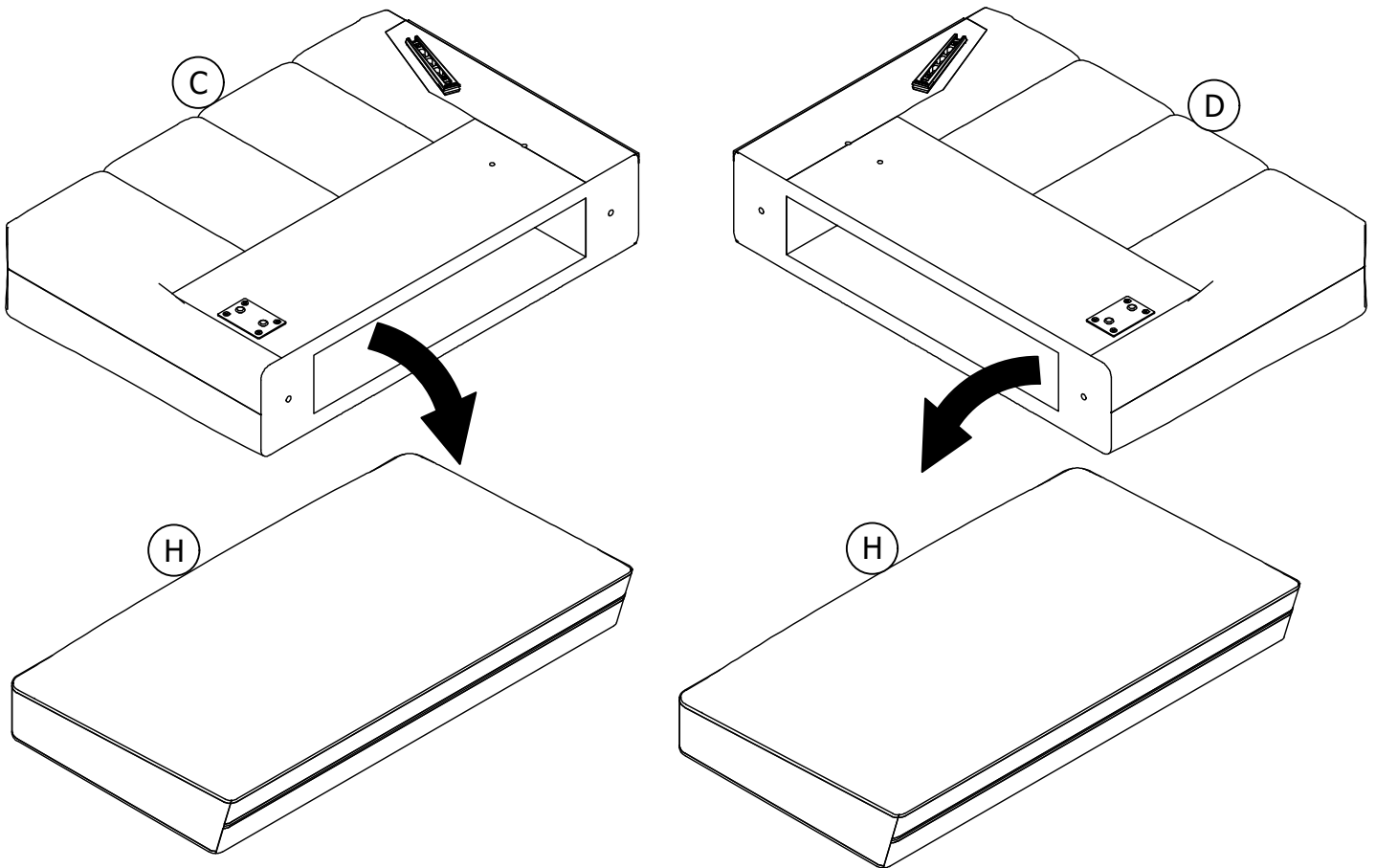

STEP 2:

Attach Bracket **N** x 2 to Armrest **C** & **D** with bolts **4**, as shown.

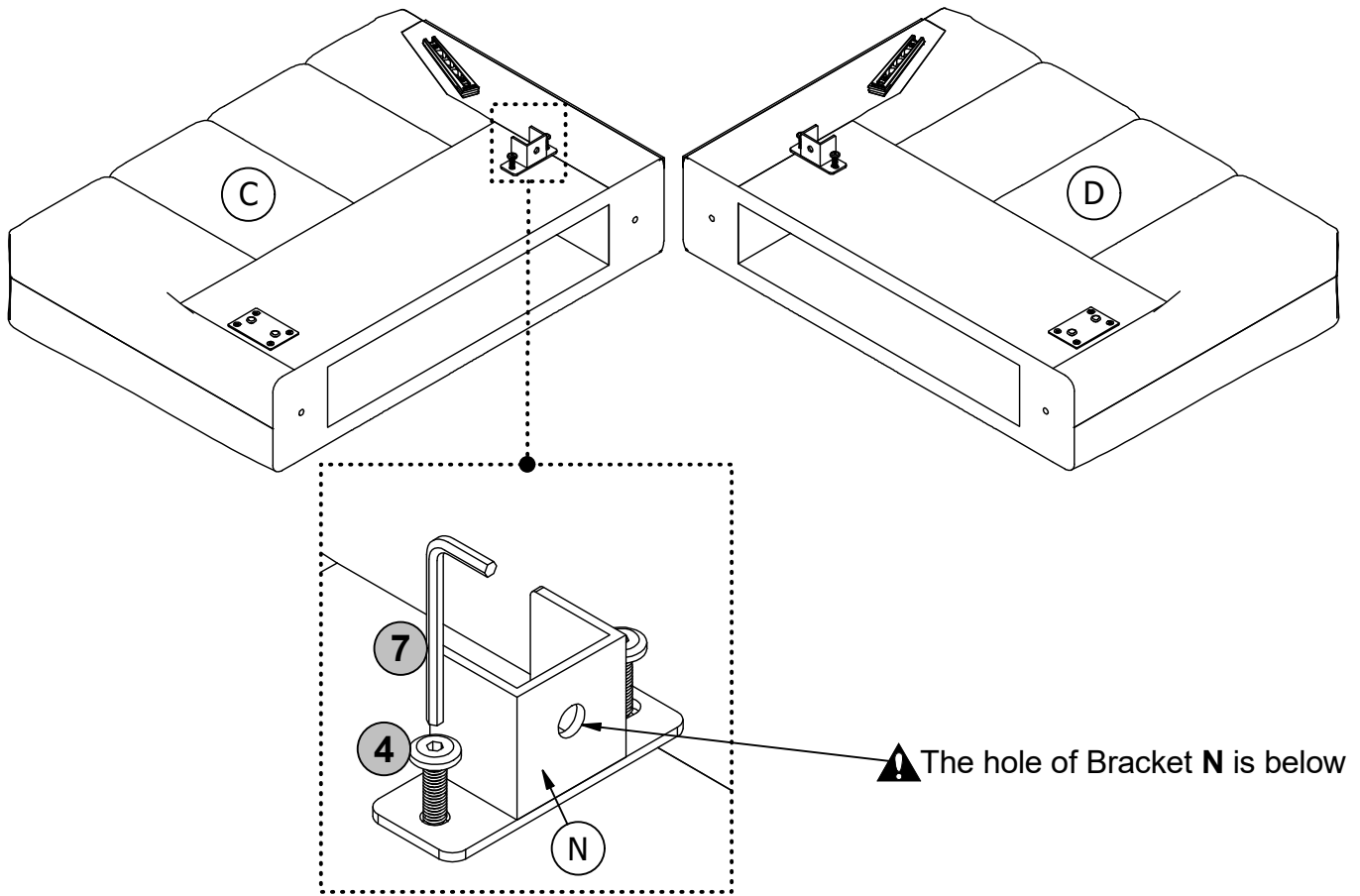

STEP 3:

Attach Leg **Q** x 4 to Armrest **C** & **D** with bolts **1**, washer **5**, as shown.

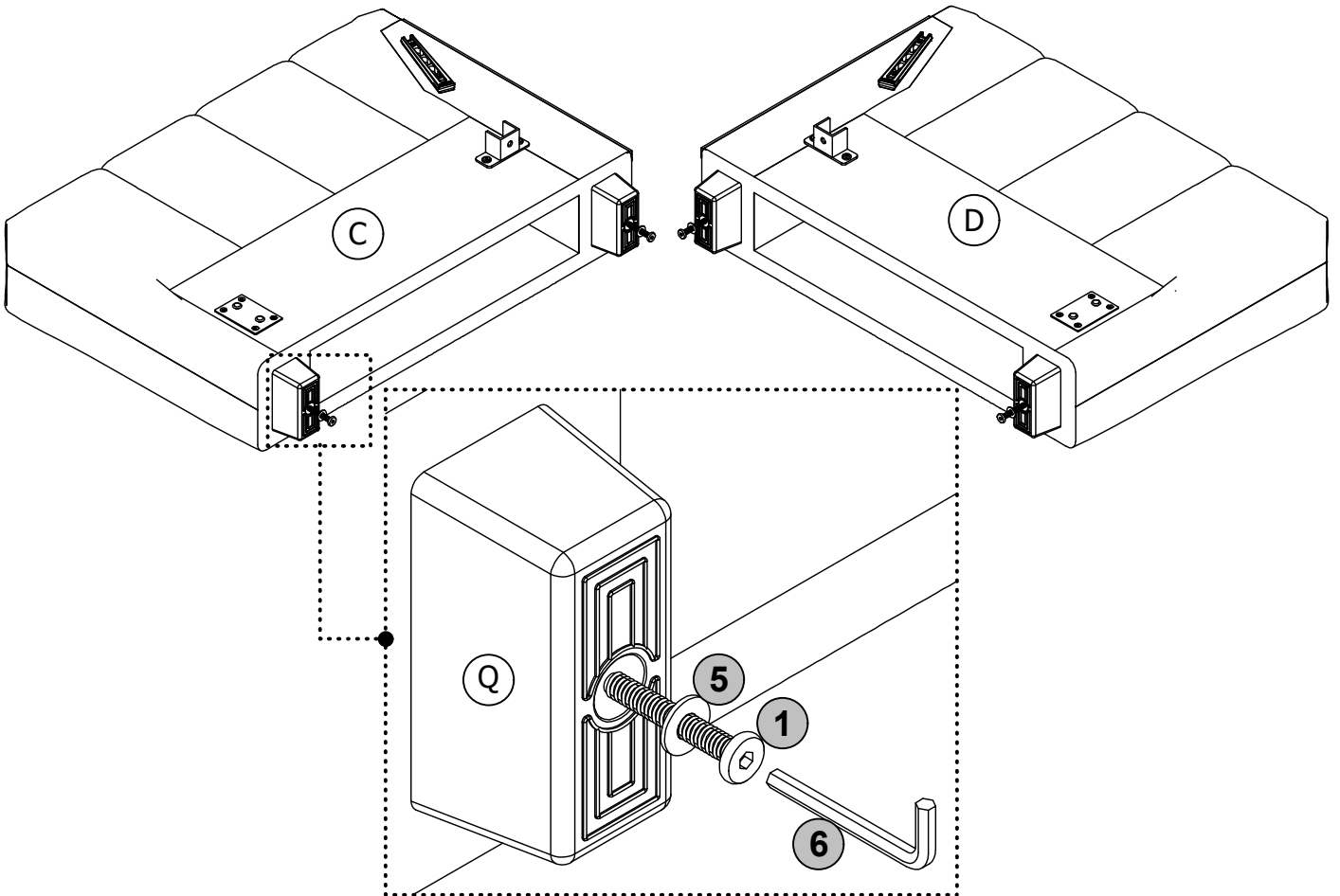

STEP 4:

Attach Front Middle Leg **L** to Front Rail **E** & **F** with bolts **4**, as shown.

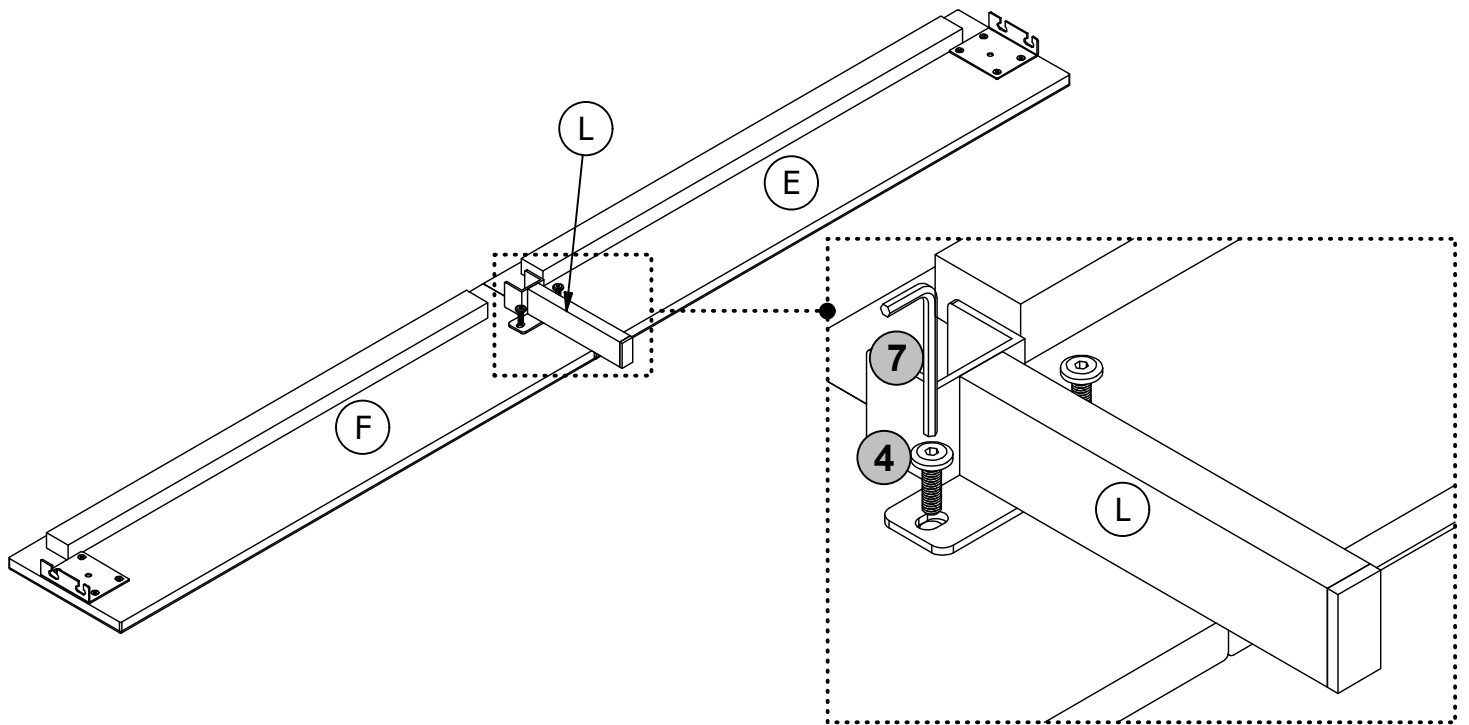

STEP 5:

Attach Front Rail **E** & **F** to Armrests **C** & **D** by inserting the brackets on Front Rail **E** & **F** into the metal plate on Armrests **C** & **D**, as shown.

Push Front Rail **E** & **F** with a downward force to secure it into place.

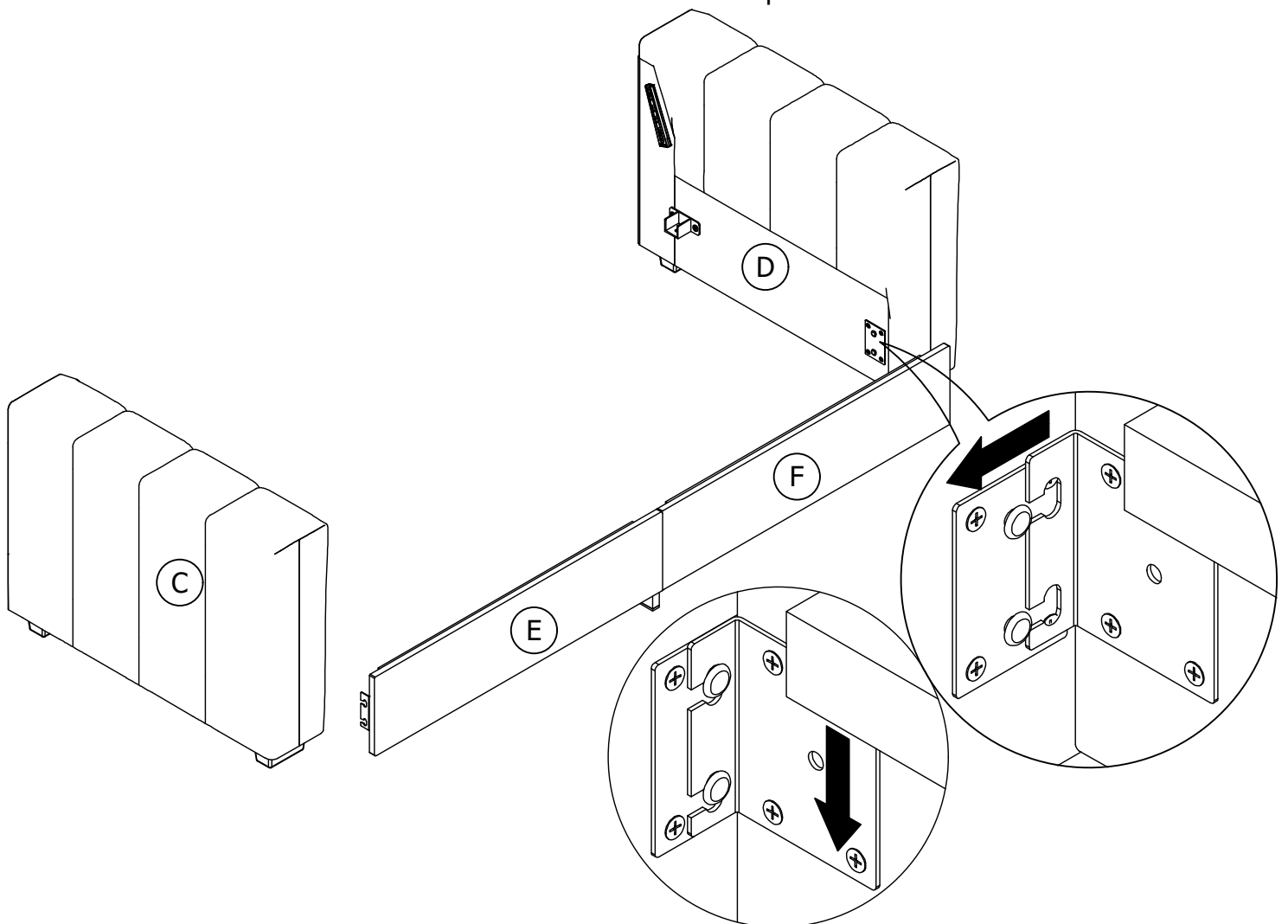

STEP 6:

Attach Rear Rail **J** x 2 to Bracket **N** x 2 & Rear Middle Leg **M**.

6.1 Attach Rear Rail **J** x 2 to Rear Middle Leg **M** with bolts **2**.

6.2 Attach Rear Rail **J** x 2 to Bracket **N** x 2 with bolts **2**, as shown.

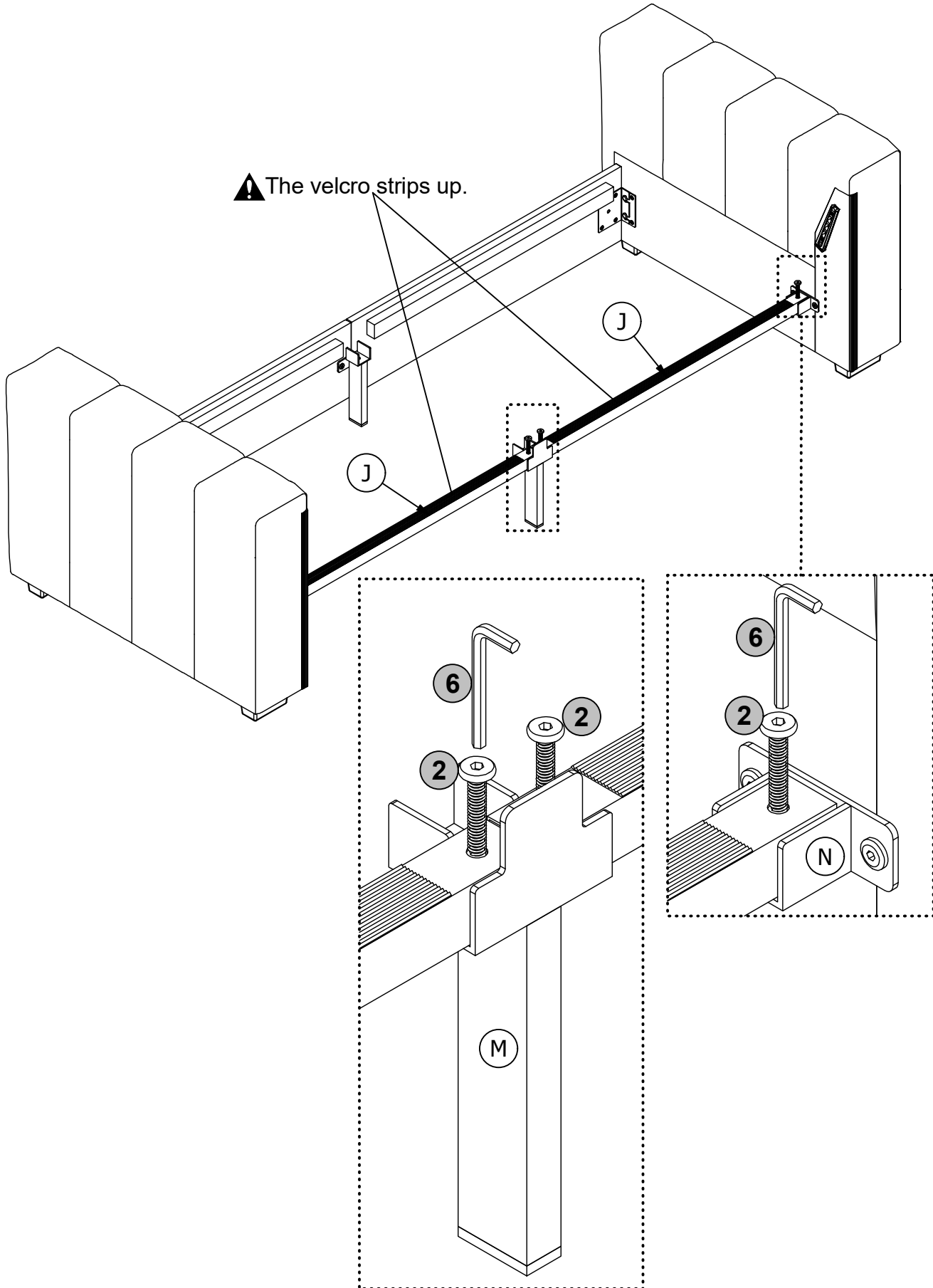

STEP 7:

Attach Middle Connector **K** to Front Middle Leg **L** & Rear Middle Leg **M** with bolts **2**, as shown.

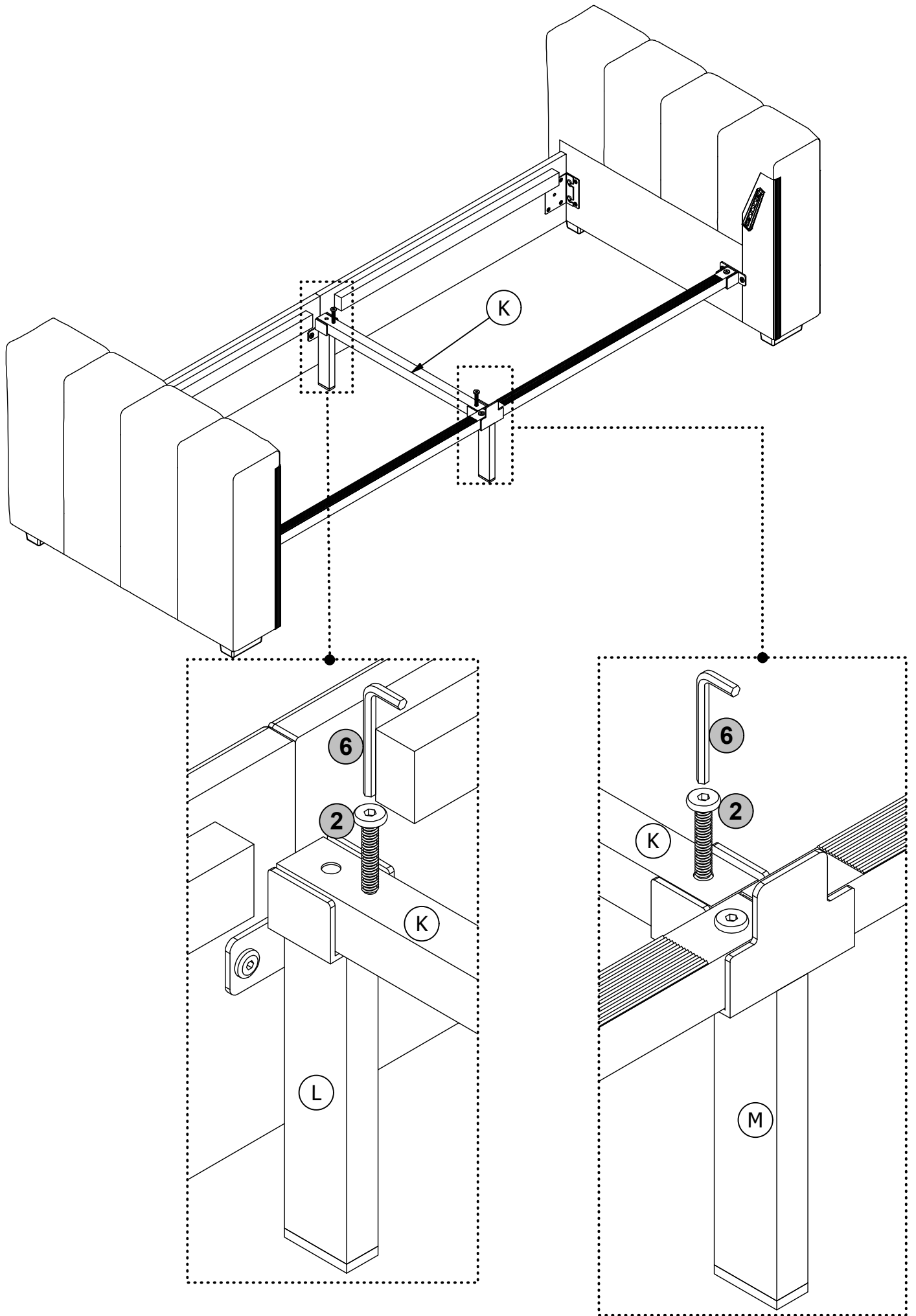

STEP 8:

Connect Back Frame **A** & **B** using Connector **O**, as shown.

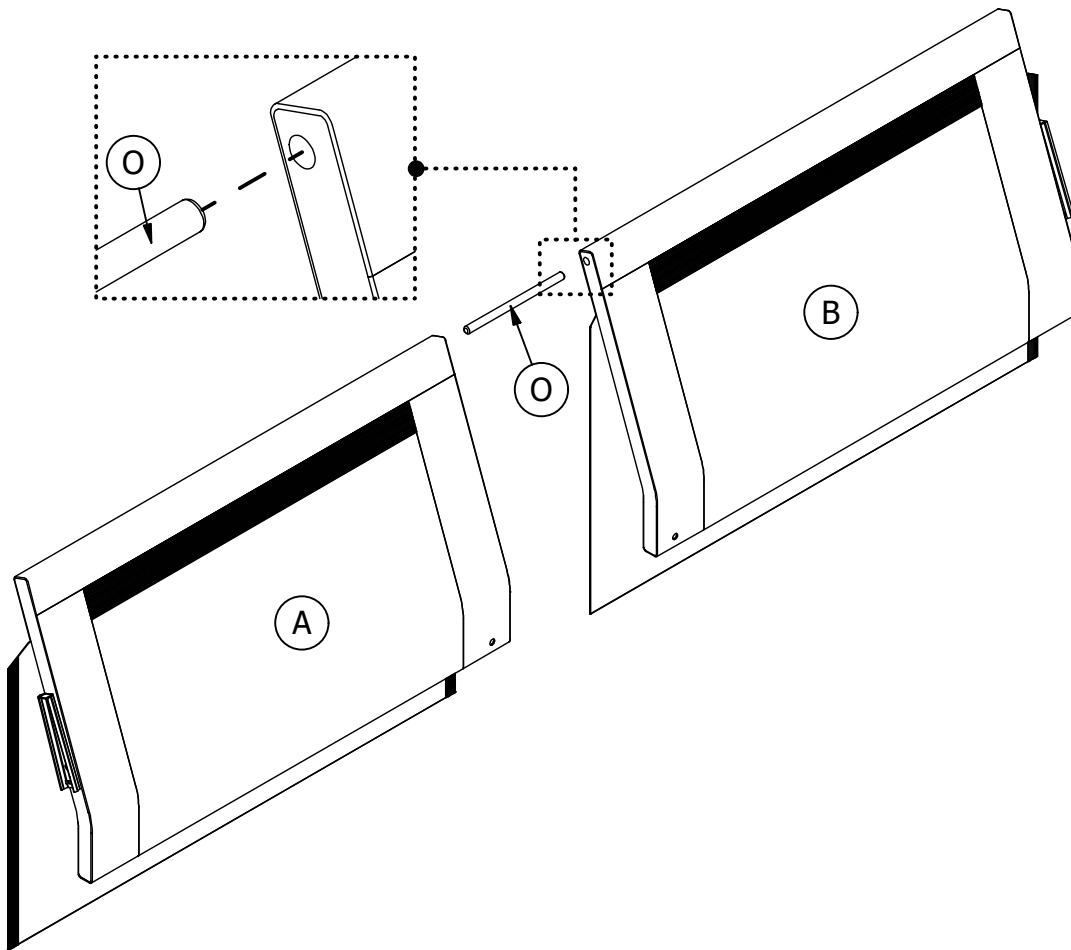

STEP 9:

Attach Plug-in **P** to Back Frame **A** & **B** with bolt **3**, as shown.

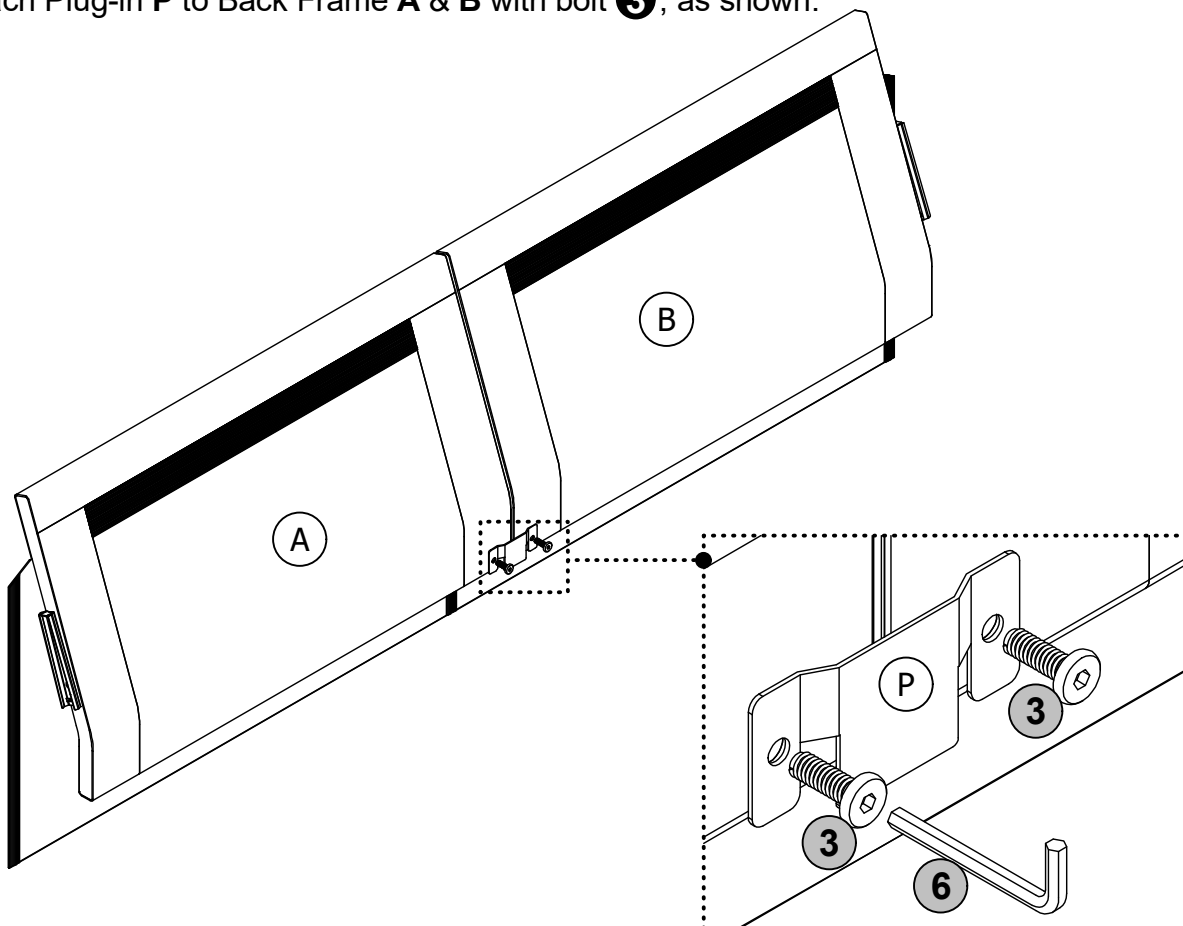

STEP 10:

Attach Back Frame **A** & **B** to Armrest **C** & **D** by inserting the brackets on Back Frame **A** & **B** to the metal glides on Armrest **C** & **D**.

Attach Back Frame **A** & **B** to Rear Middle Leg **M** by inserting the Plug-in **P** on Back Frame **A** & **B** to Rear Middle Leg **M**.

Push Back Frame **A** & **B** downwards to secure it into place.

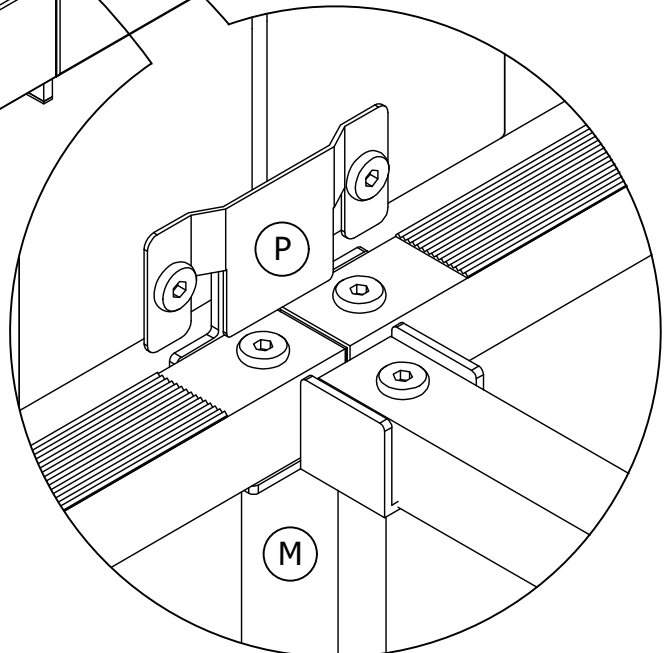
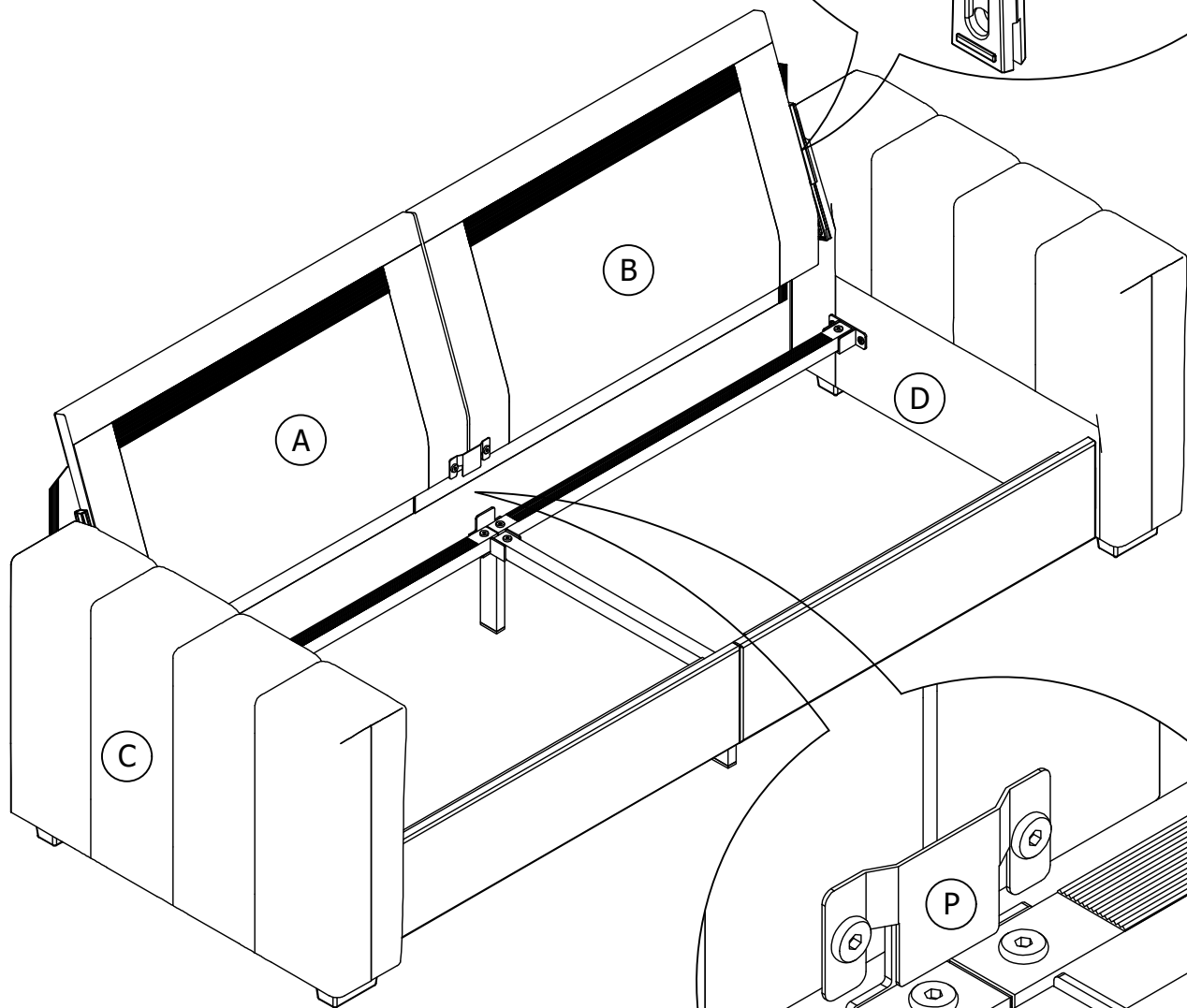
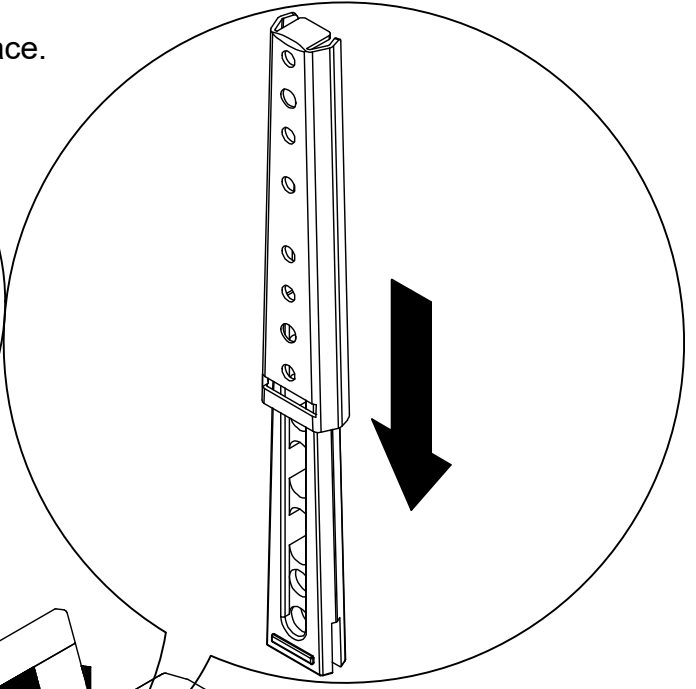
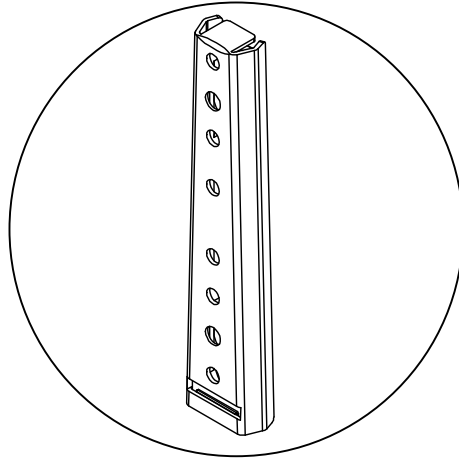

STEP 11:

Stick fabric cover on Back Frame **A** & **B** to Armrests **C** & **D** with the velcro strips.

Stick fabric cover on Left Back Frame **A** to Right Back Frame **B** with the velcro strips, as shown.

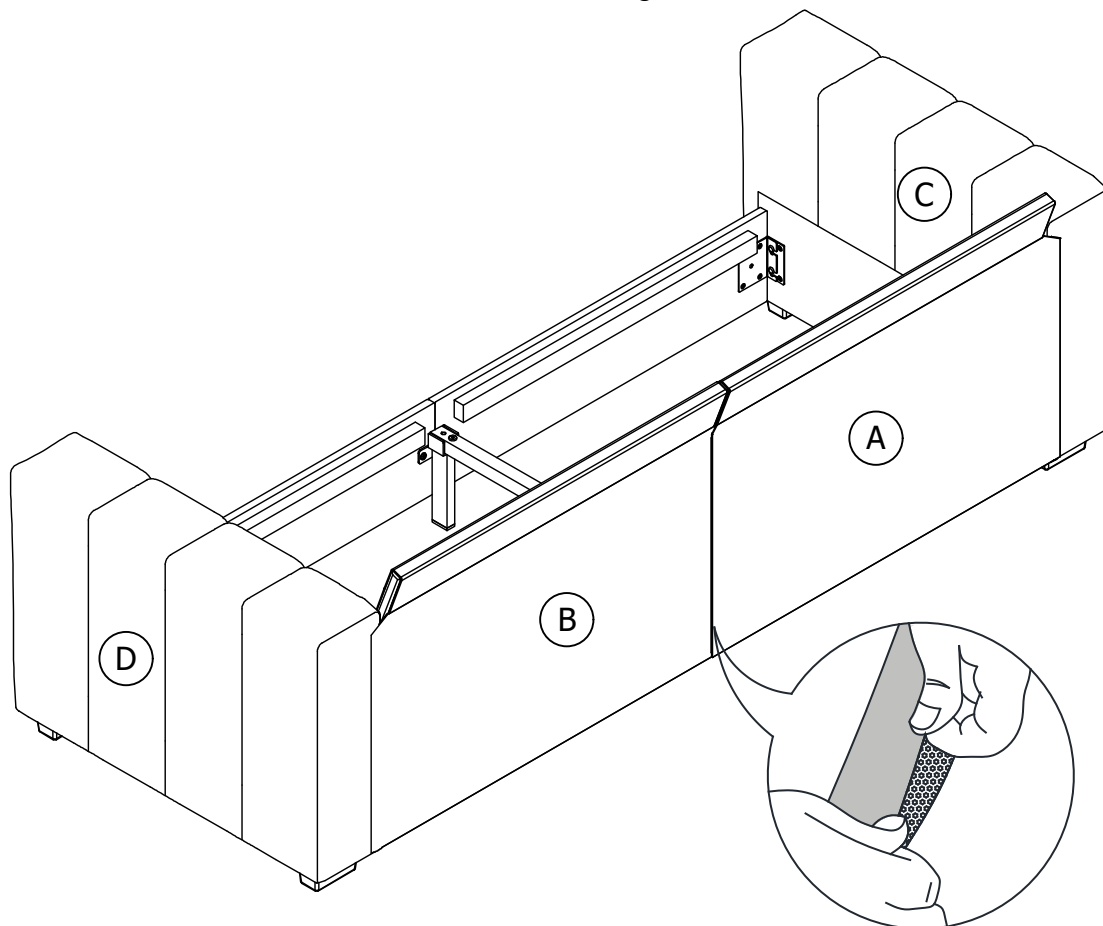

STEP 12:

Unfold Seat Panel **I** x 2.

Place Seat Panel **I** x 2 onto the seat using the Velcro strips.

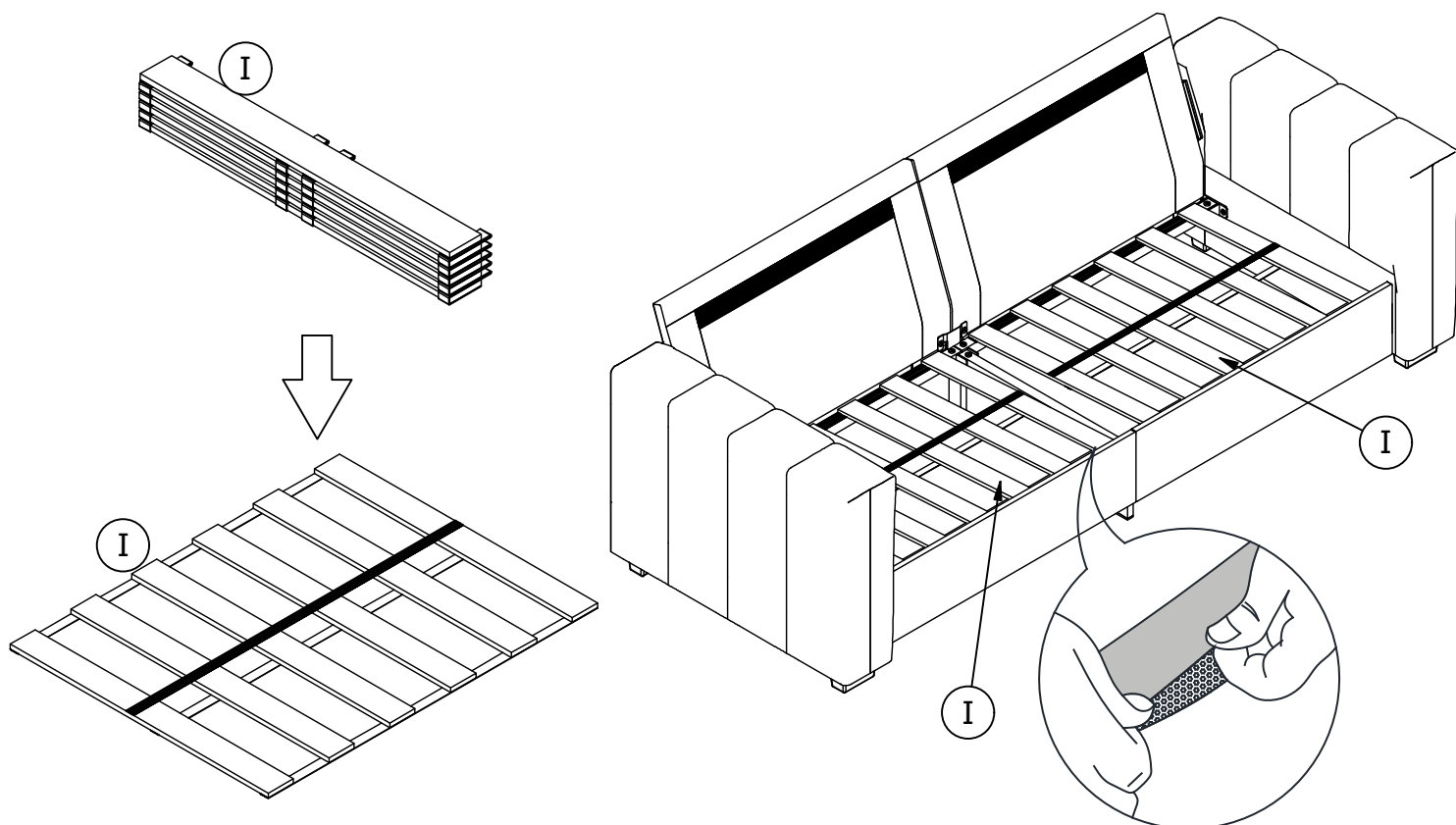

STEP 13:

13.1 Remove the Cushion **G** x 2 & **H** x 2 from their vacuum sealed package.

13.2 Open Seat Cushions **G** x 2.

13.3 Place Seat Cushions **G** x 2 onto the sofa using the velcro strips.

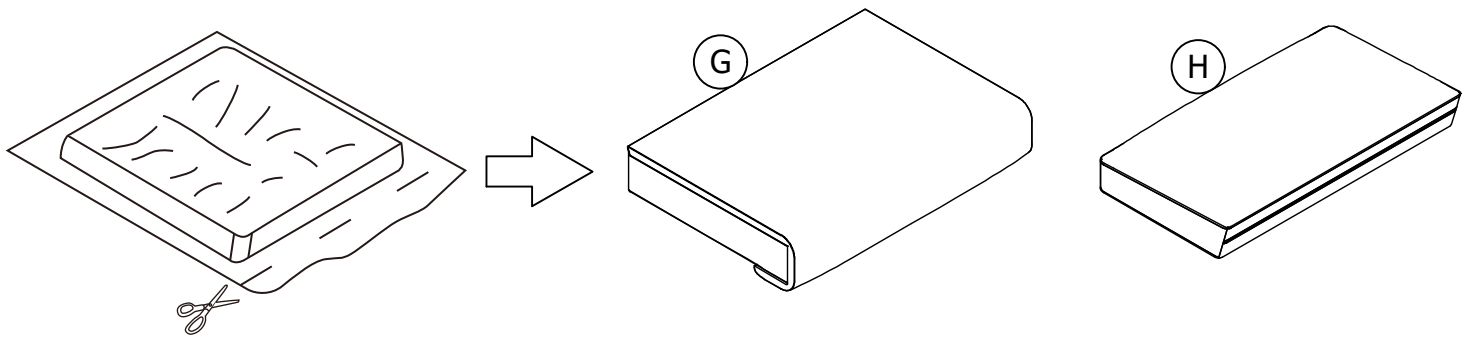

13.1

Note: The cushions have been vacuum packed for transportation purposes. After unpacking, please allow up to 72 hours so that it can return to its original shape.

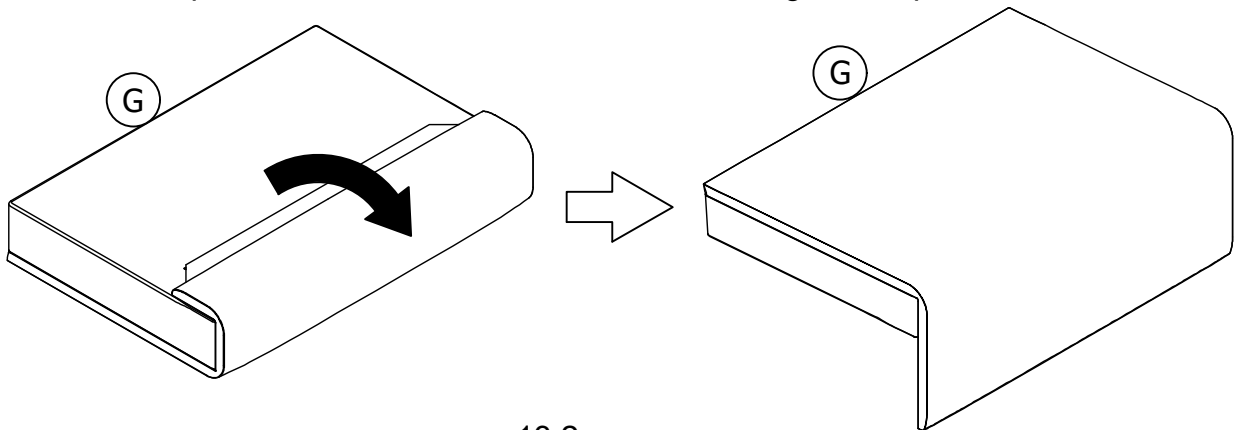

13.2

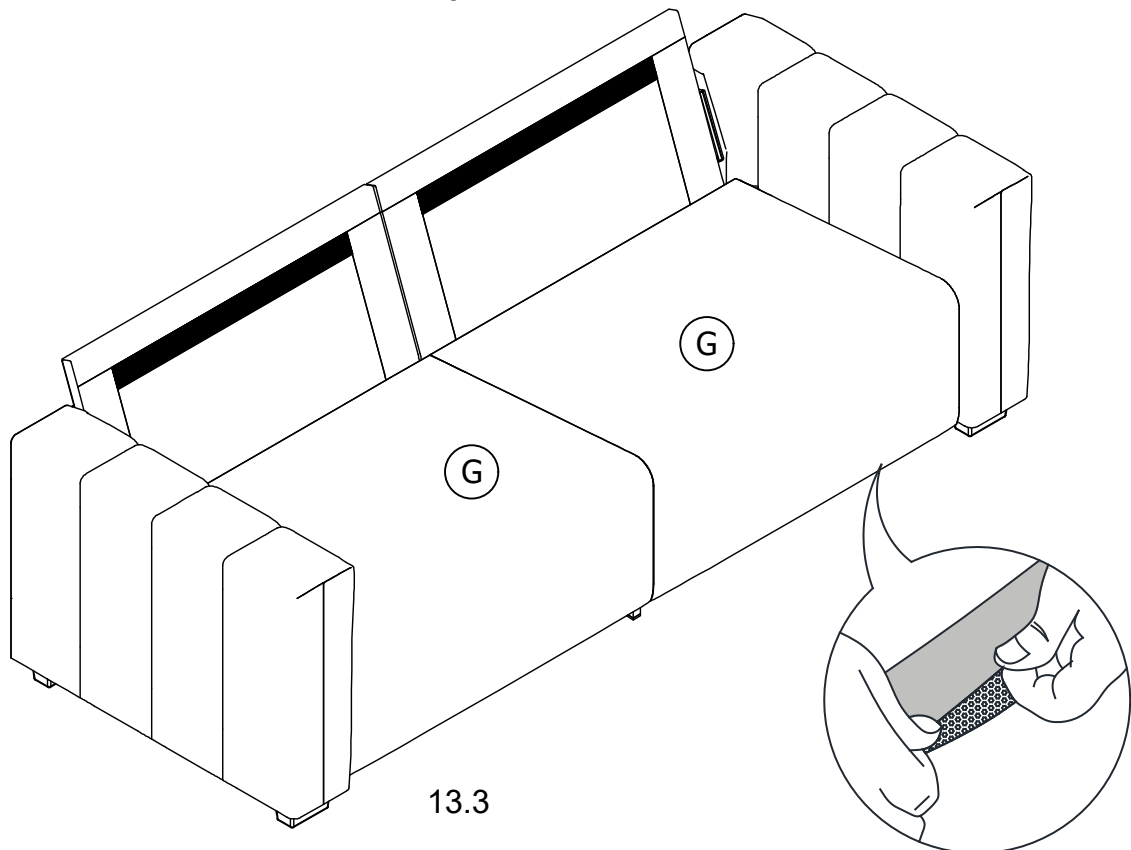

13.3

STEP 14:

Place Back Cushions H x 2 onto the sofa.

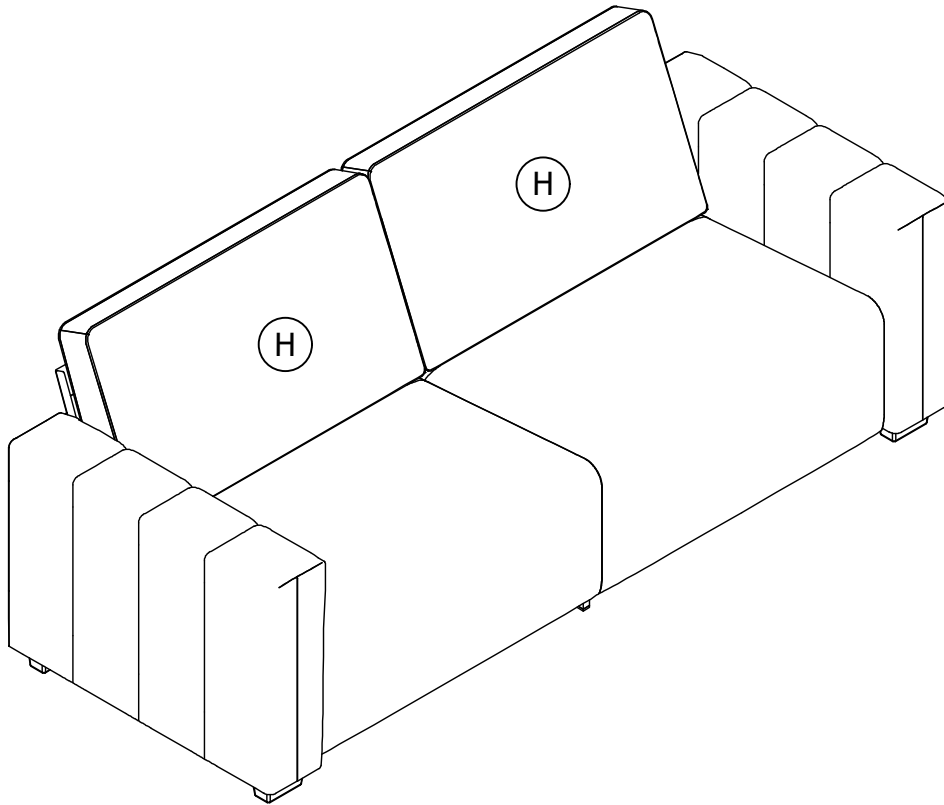

Helpful Hints

- Your futon can transform between a Sofa and a Bed.
- Move your new furniture carefully, with two people lifting and carrying the unit to its new location.
- Your furniture can be disassembled and reassembled to move.
- Clean the product with a soft damp cloth. DO NOT use harsh chemicals or abrasive cleaners.
- For further information please contact at sales4@jsanyee.com

