

ASSEMBLY INSTRUCTIONS

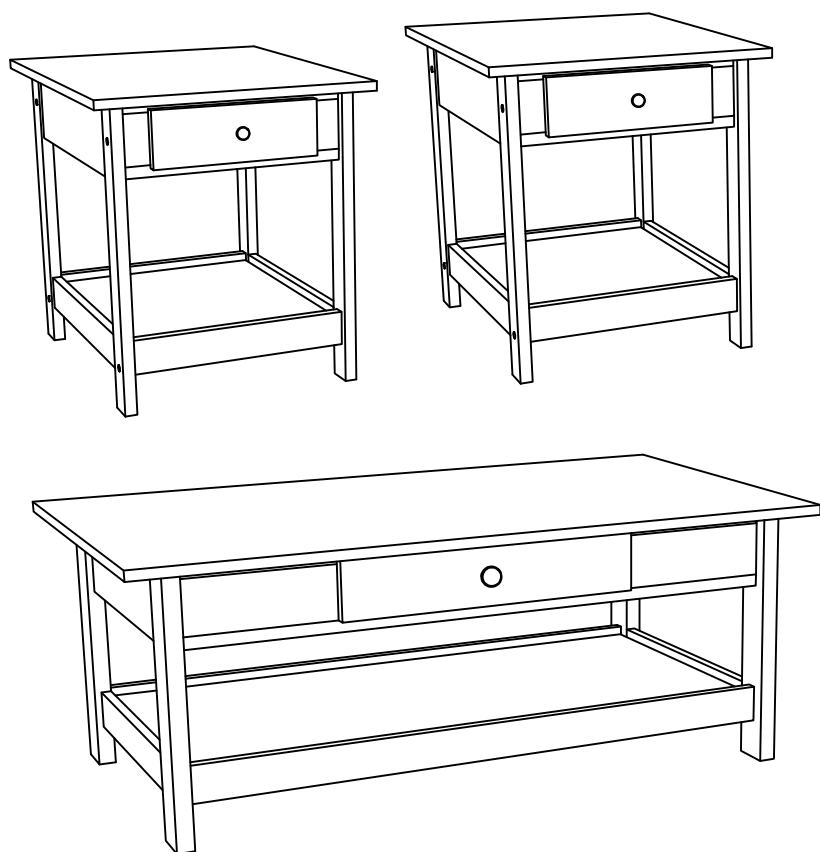

TOOLS REQUIRED



Allen Wrench

(Included)



Phillips
Screwdriver

(Not Included)



**2 - People
Recommended**

ASSEMBLY RATING



EASY —————> DIFFICULT

The Assembly Rating is a 5-point system showing the level of effort needed to assemble a specific product.



CHECK BEFORE STARTING

Are you missing anything?

Double-check all parts, hardware and accessories listed are all accounted for.

Should we send any replacements?

Are there any irregularities or flaws in the parts? We can send replacements!

Check out our Quick Tips!

We recommend reviewing the pre-assembly handouts. Even experts need a refresher now and then!

Prep Time!

Please review the assembly instructions and all diagrams prior to assembling.

PRE ASSEMBLY INTRODUCTION

We understand building ready-to-assemble furniture can be a challenging experience for some. To help avoid confusion, we have provided some helpful tips that may speed up the process.



Teamwork

ALWAYS have at least two people to help with transporting and assembling the product to avoid potential injury and/or damage.

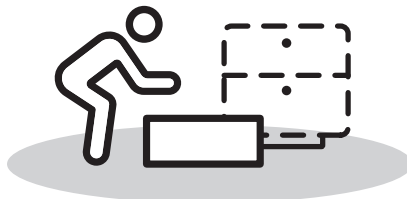
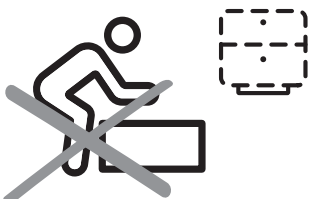

Suitable Location

Assembling near the area of the intended location is highly recommended.



Sufficient Space

Make sure you have enough space to move around during the assembly.



Avoid Scratches

Use cardboard, blankets or a carpeted area while assembling furniture to prevent to prevent scratches and damages.



Flat Surface

Make sure the furniture rests on a flat and level surface with each leg evenly touching the floor.

ASSEMBLY AND CARE ADVICE



FAILURE TO FOLLOW THE GUIDELINES BELOW MAY RESULT IN INJURY AND/OR PROPERTY DAMAGE.



Position each part correctly and insert screws or bolts into their respective holes.



Use the appropriate hand tools or power tools for assembly. Select steps, such as tightening screws and/or bolts, may require hand tools to avoid causing damage during assembly.



Turn clockwise to tighten and only tighten when step is completed or when instructed to do so.



Save the instructions and store any supplied tools for later maintenance.



After two weeks, check and tighten any loose hardware and repeat again every six months thereafter.

IT IS THE USER'S RESPONSIBILITY TO MAINTAIN THE FURNITURE. THE HARDWARE MAY LOOSEN OVER TIME AND MAY CAUSE THE FURNITURE TO BE WOBBLY AND UNABLE TO SUPPORT ITS INTENDED WEIGHT CAPACITY. THIS MAY LEAD TO COLLAPSE AND MAY CAUSE SERIOUS INJURY.

COFFEE TABLE

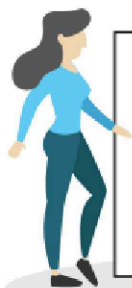

- Please keep instructions for future reference.
- Check the quantity and irregularity of parts and hardware before you start.

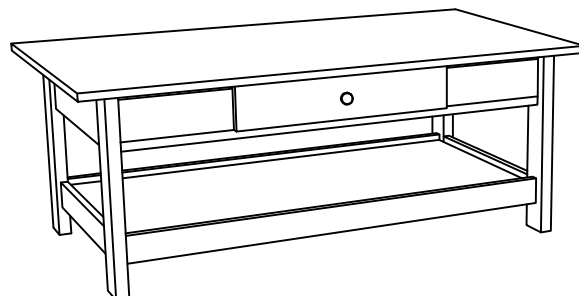

PARTS

#1 1pc



Top Panel

#5 2pcs



Base Support Rail

#2 1pc



Front Panel

#6 1pc



Shelf Panel

#3 1pc

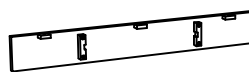

Back Panel

#7 1pc



Drawer

#4 2pcs

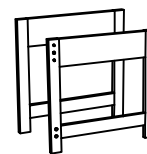

Leg Frame

#8 2pcs



Wooden Glide

HARDWARE

#A 1pc

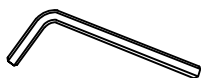

Allen Key M4

#B 8pcs

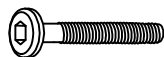

Bolt 1/4 x 2 3/8 "

#C 8pcs



Flat Washer

#D 8pcs



Lock Washer

#E 8pcs



Barrel Nut M6

#F 10pcs



Pan Head Screw
M4 x 25mm

#G 1pc



Plastic Drawer
Stopper

#H 1pc

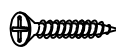

Flat Head Screw
M4 x 12mm

#I 18pcs



Wood Dowel
M8 x 30mm

ASSEMBLY INSTRUCTIONS

1

- Part #2 x1pc
- Part #3 x1pc
- Part #4 x2pcs
- Hardware #B x4pcs
- Hardware #C x4pcs
- Hardware #D x4pcs
- Hardware #E x4pcs
- Hardware #I x4pcs

Insert Barrel Nut (#E) unto Back Panel (#3)

Insert Wood Dowel (#I) unto Leg Frame (#4)

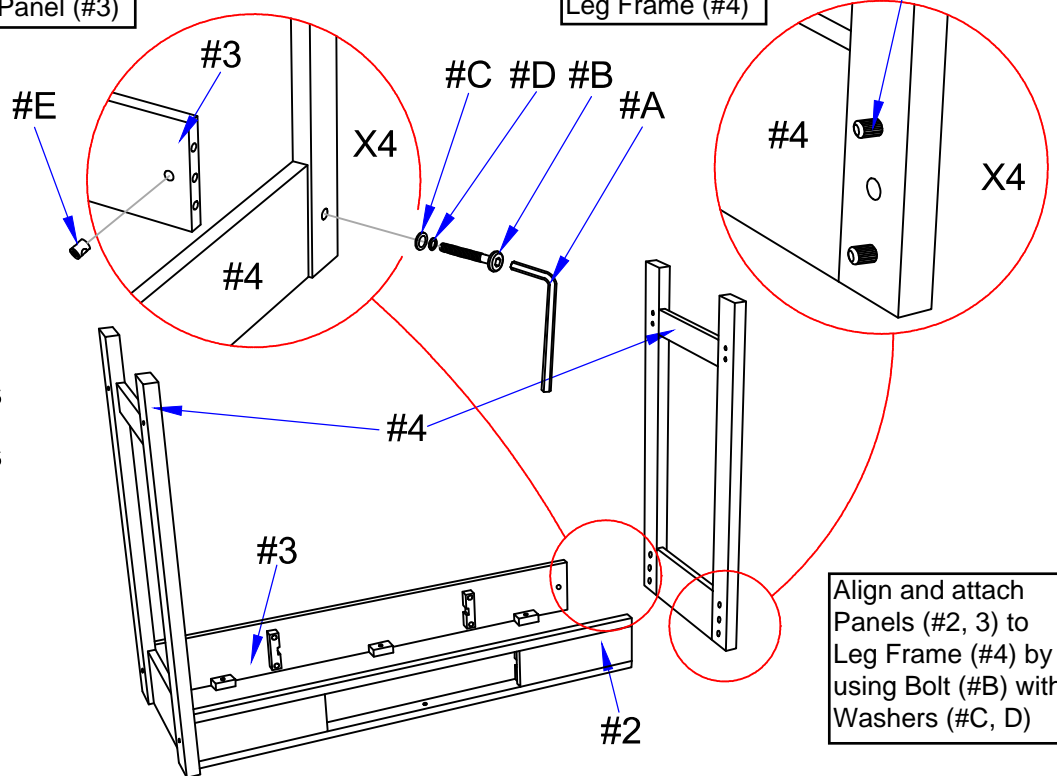

2

- Part #5 x2pcs
- Hardware #B x4pcs
- Hardware #C x4pcs
- Hardware #D x4pcs
- Hardware #E x4pcs
- Hardware #I x4pcs

Insert Wood Dowel (#I) to Rail (#5)

Align and attach Rail (#5) using Bolt (#B) with Washers (#C, D)

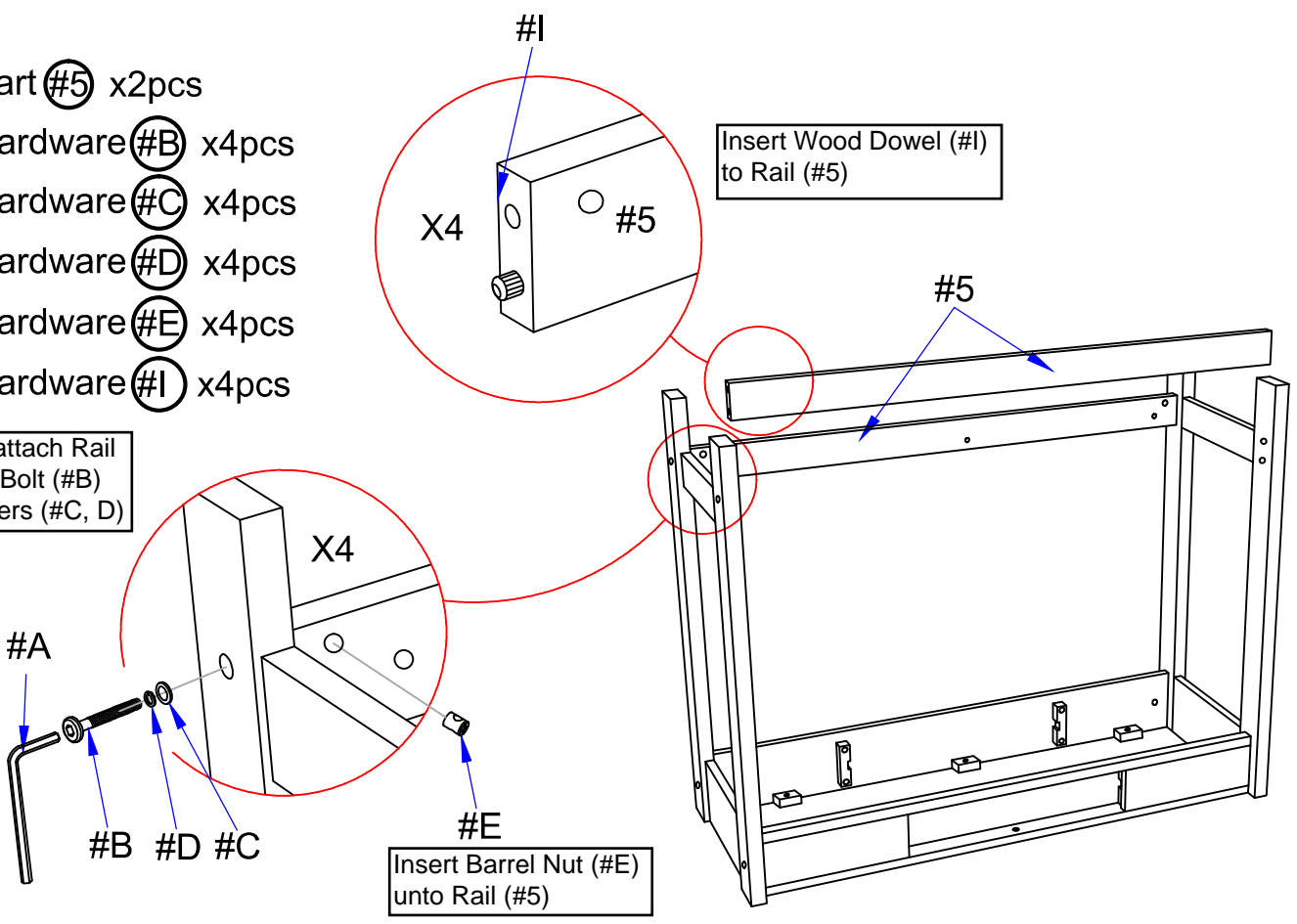

ASSEMBLY INSTRUCTIONS

3

Part (#8) x2pcs

Hardware (#F) x4pcs

Insert Wooden
Glide (#8) and
secure using Pan
Head Screw (#F)

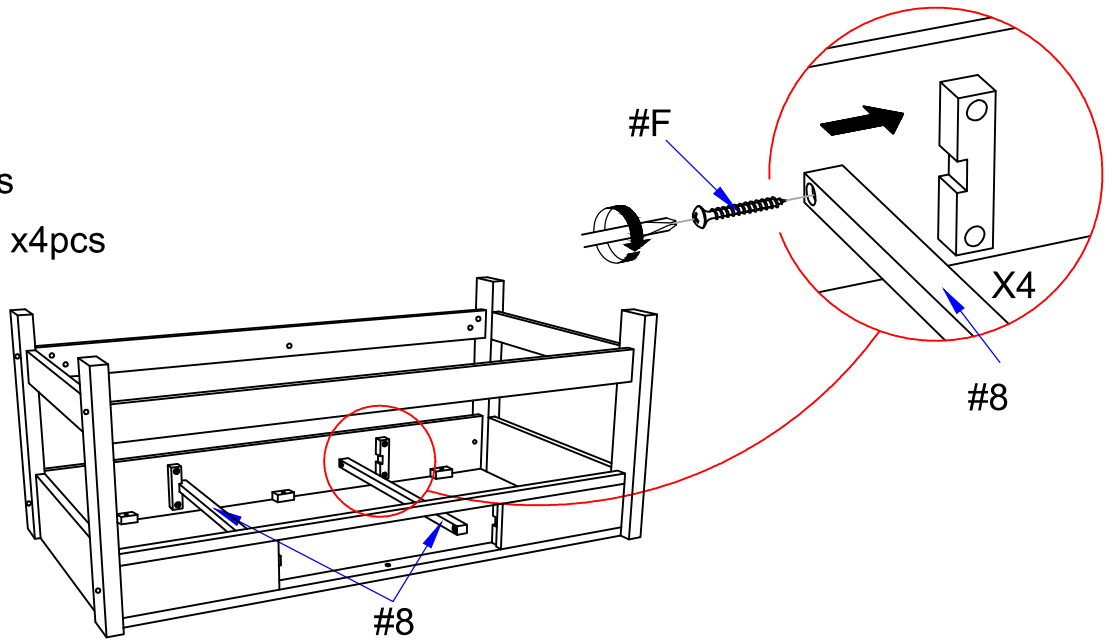

4

Part (#1) x1pc

Hardware (#F) x6pcs

Corner Marking

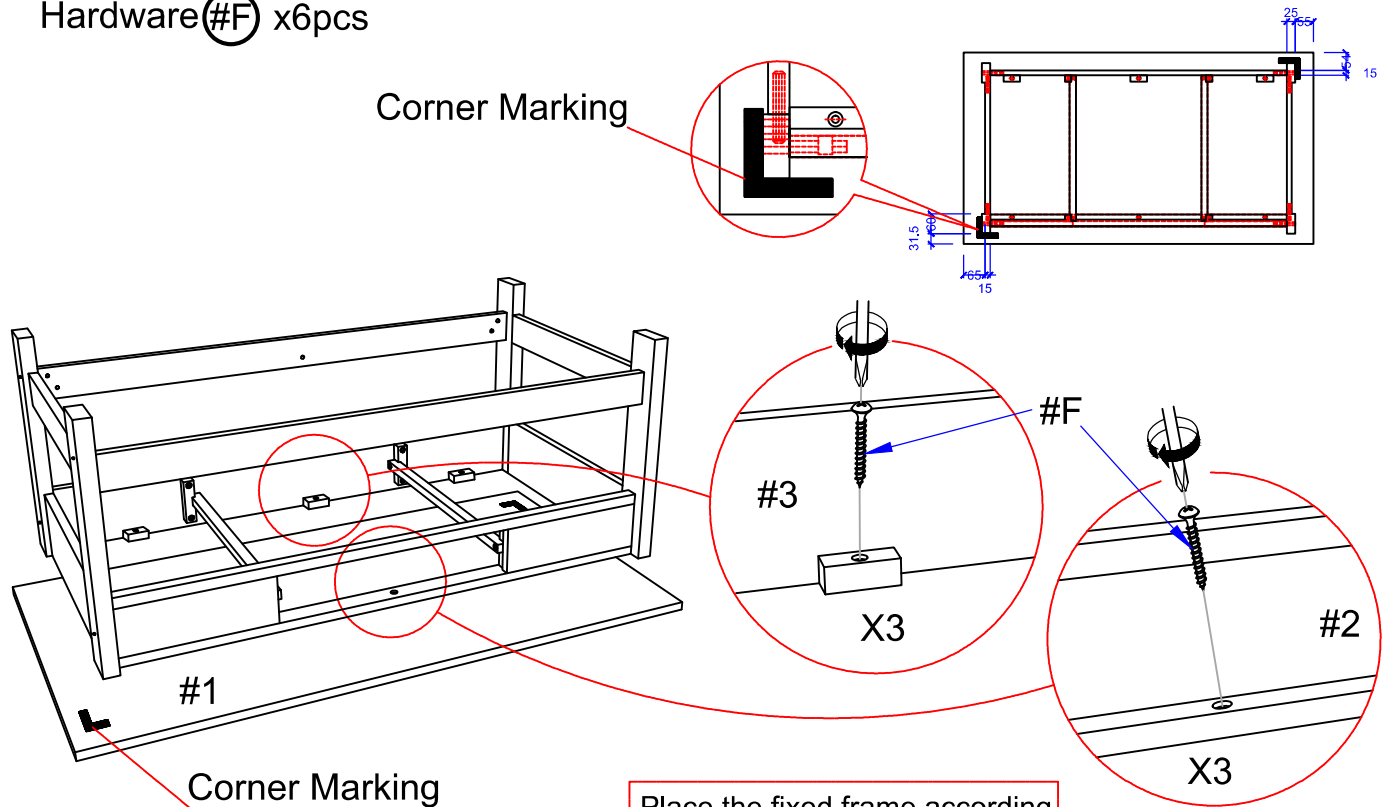

Place the fixed frame according
to the corner marking made on
Top Panel (#1).

ASSEMBLY INSTRUCTIONS

5

Part (#6) x1pc

Hardware (#I) x6pcs

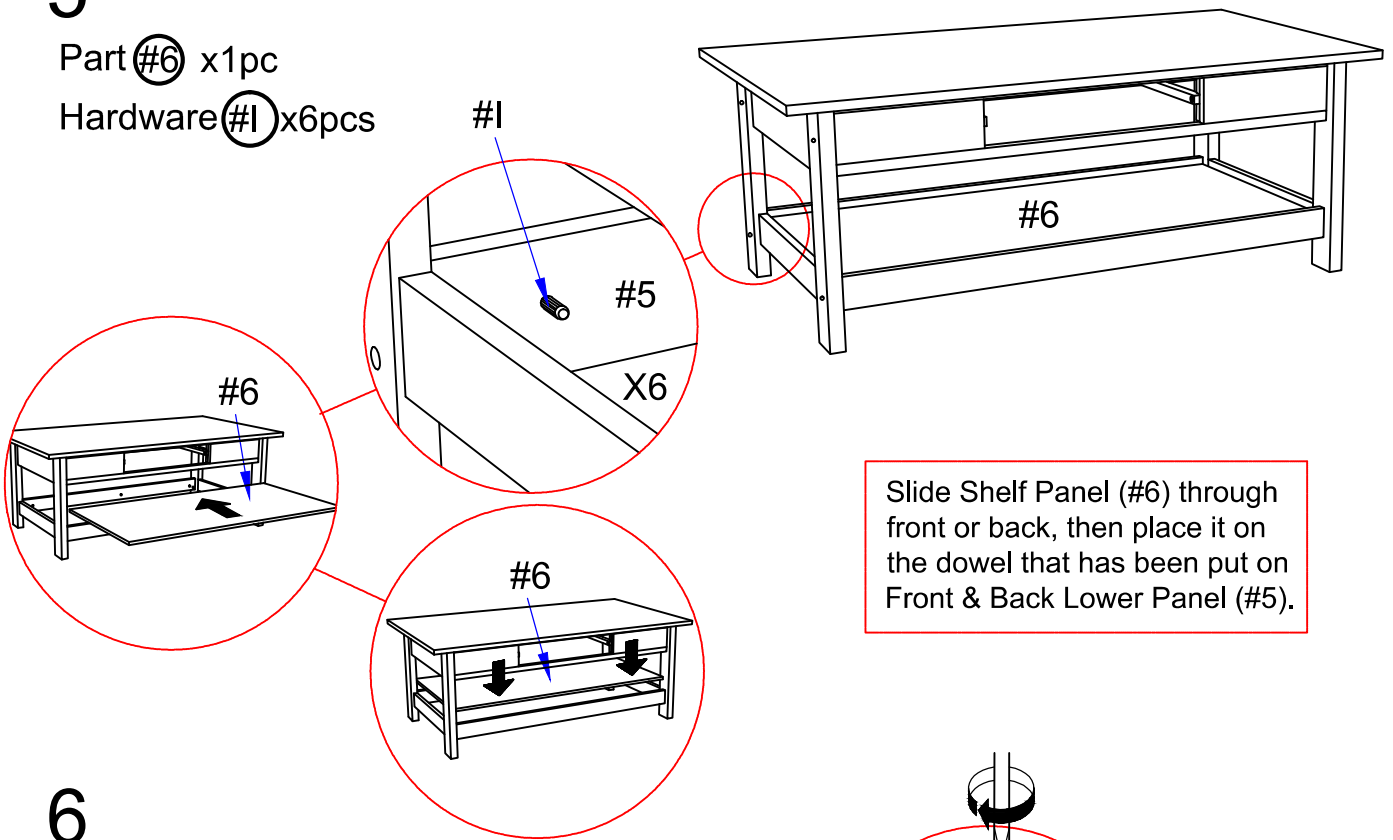

6

Part (#7) x 1pc

Hardware (#G) x1pc

Hardware (#H) x1pc

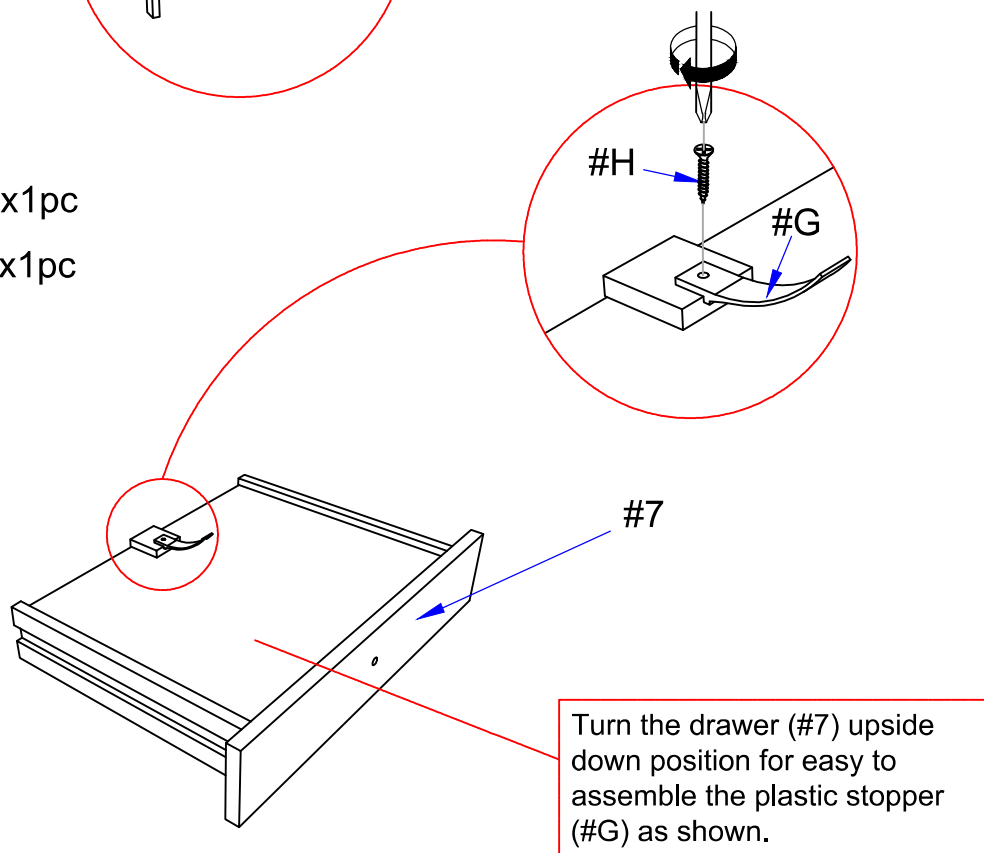

ASSEMBLY INSTRUCTIONS

7

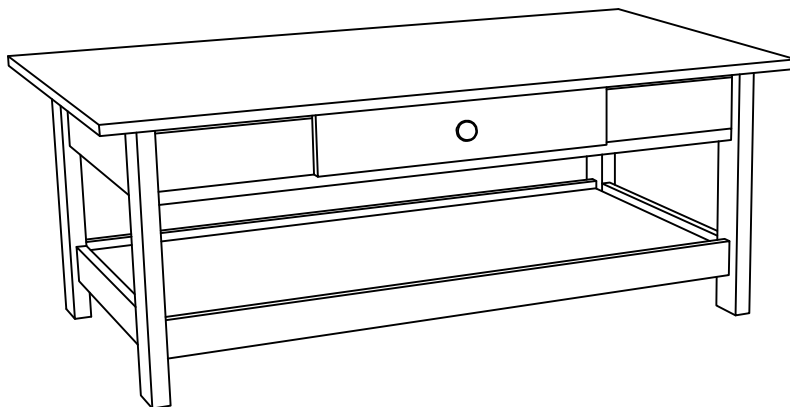
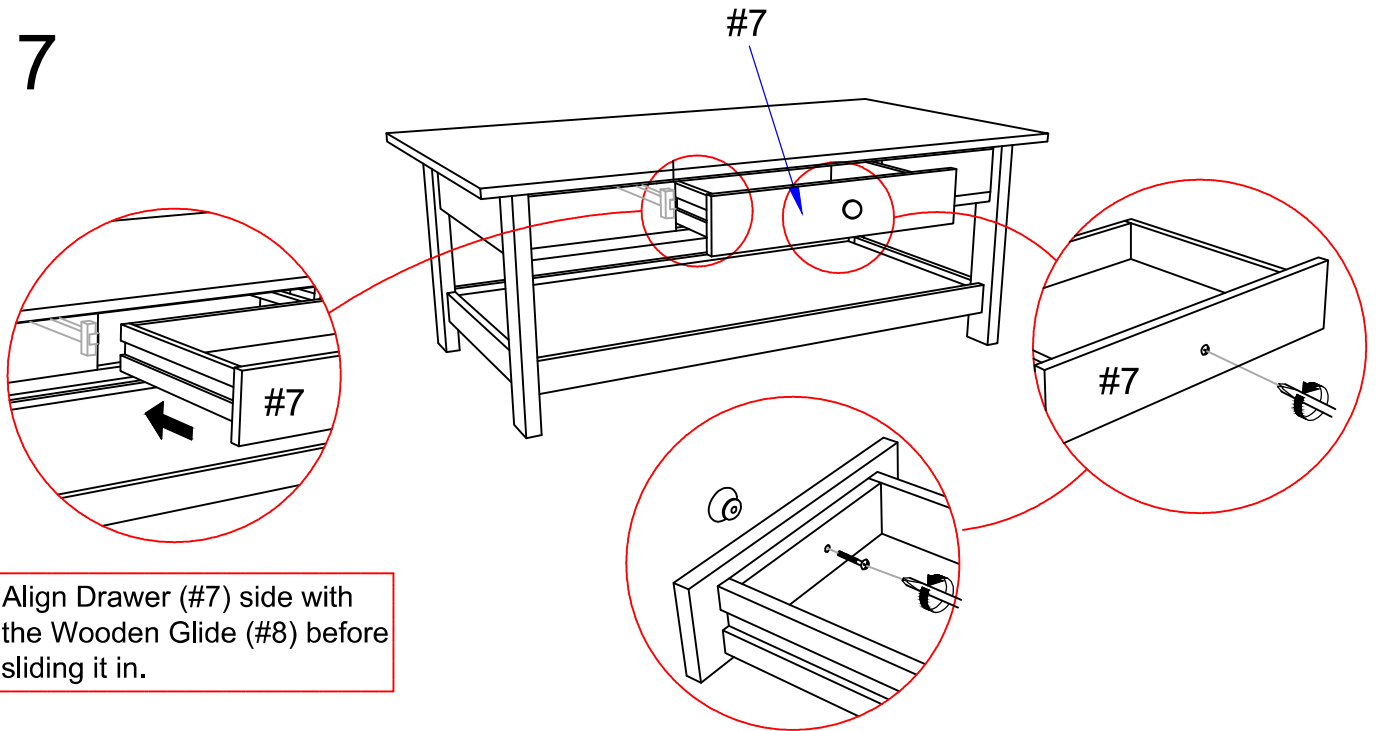

ASSEMBLY COMPLETED



Please ensure the furniture rests on an even and flat surface. If the product wobbles or feels loose, double-check all bolts and/or screws are properly tightened and secured.



Keep this handy!

Please retain this instruction manual and any order-related information for future reference.



Lift, don't drag!

To avoid damage to product please always LIFT the product when transporting or adjusting the placement.

END TABLE



- Please keep instructions for future reference.
- Check the quantity and irregularity of parts and hardware before you start.

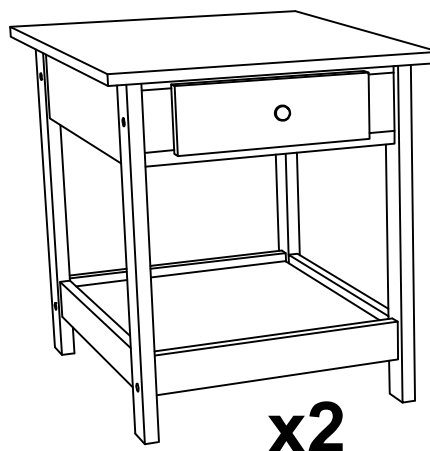

PARTS

#1 1pc x 2



Top Panel

#2 1pc x 2



Front Panel

#3 1pc x 2

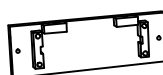

Back Panel

#4 2pcs x 2

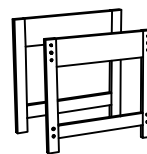

Leg Frame

#5 2pcs x 2



Base Support Rail

#6 1pc x 2



Shelf Panel

#7 1pc x 2

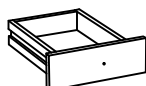

Drawer

#8 2pcs x 2



Wooden Glide

HARDWARE

#A 1pc



Allen Key M4

#B 8pcs x 2

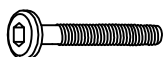

Bolt 1/4 x 2"

#C 8pcs x 2



Flat Washer

#D 8pcs x 2



Lock Washer

#E 8pcs x 2



Barrel Nut M6

#F 8pcs x 2

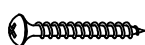

Pan Head Screw
M4 x 25mm

#G 1pc x 2



Plastic Drawer
Stopper

#H 1pc x 2



Flat Head Screw
M4 x 12mm

#I 16pcs x 2



Wood Dowel
M8 x 30mm

ASSEMBLY INSTRUCTIONS

Insert Barrel Nut (#E)
unto Back Panel (#3)

1

- Part #2 x1pc
- Part #3 x1pc
- Part #4 x2pcs
- Hardware #B x4pcs
- Hardware #C x4pcs
- Hardware #D x4pcs
- Hardware #E x4pcs
- Hardware #I x8pcs

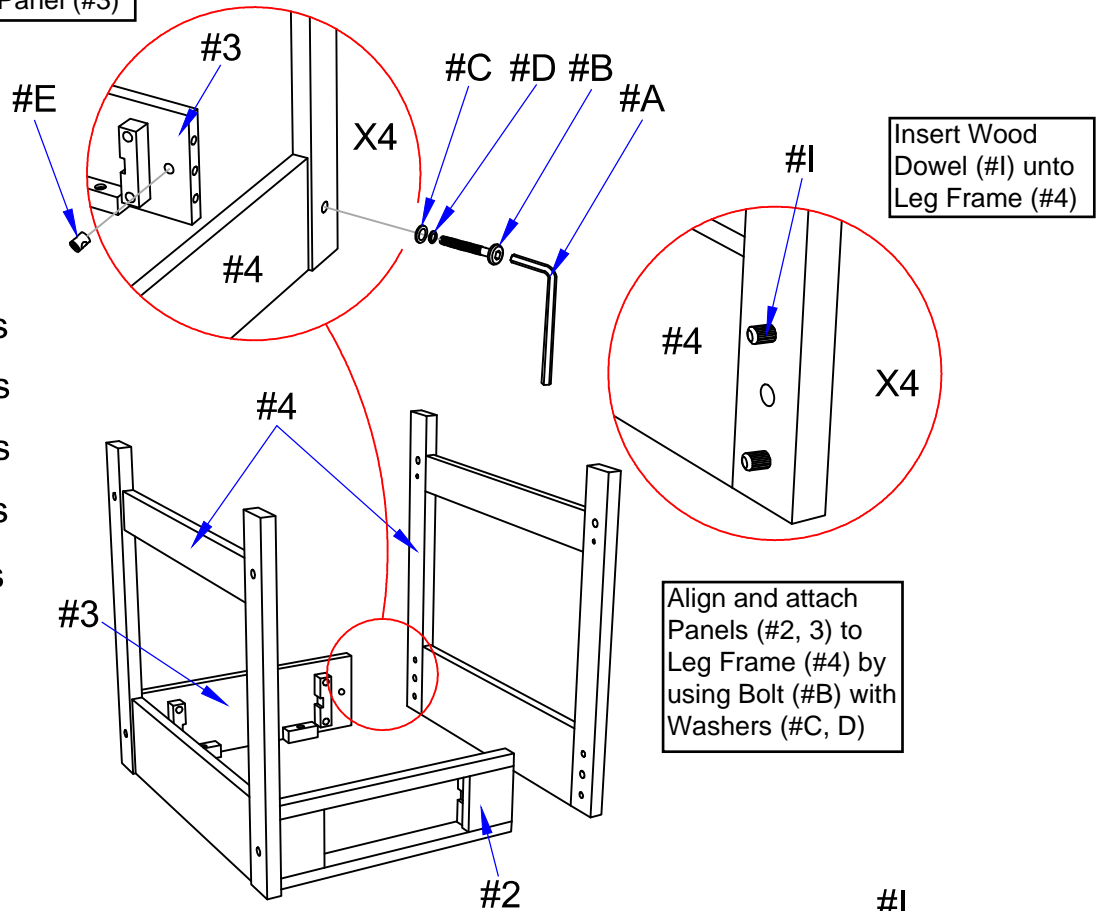

2

- Part #5 x2pcs
- Hardware #B x4pcs
- Hardware #C x4pcs
- Hardware #D x4pcs
- Hardware #E x4pcs
- Hardware #I x4pcs

Align and attach
Rail (#5) using
Bolt (#B) with
Washers (#C, D)

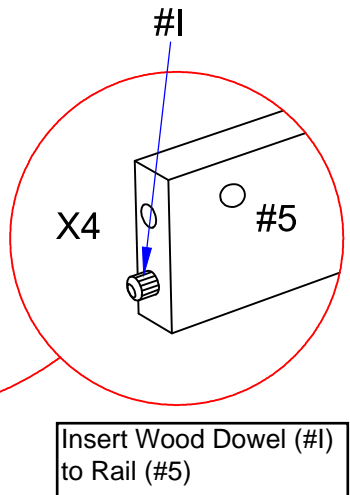

Insert Barrel Nut (#E)
unto Rail (#5)

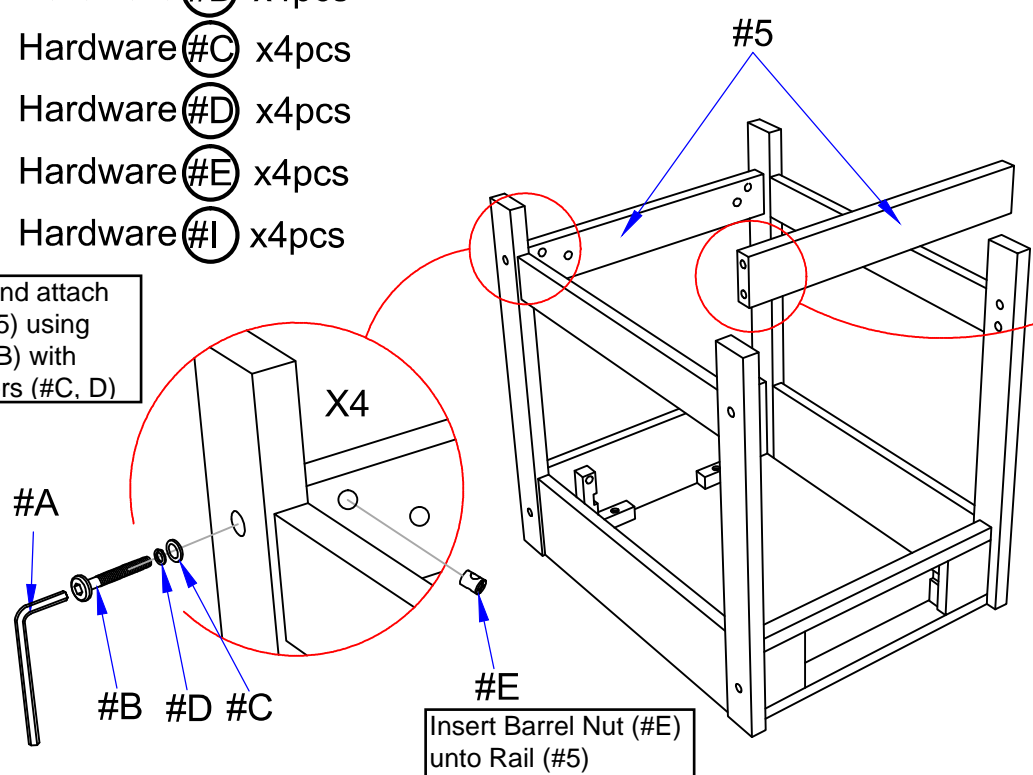

ASSEMBLY INSTRUCTIONS

3

Part (#8) x2pcs

Hardware (#F) x4pcs

Insert Wooden
Glide (#8) and
secure using Pan
Head Screw (#F)

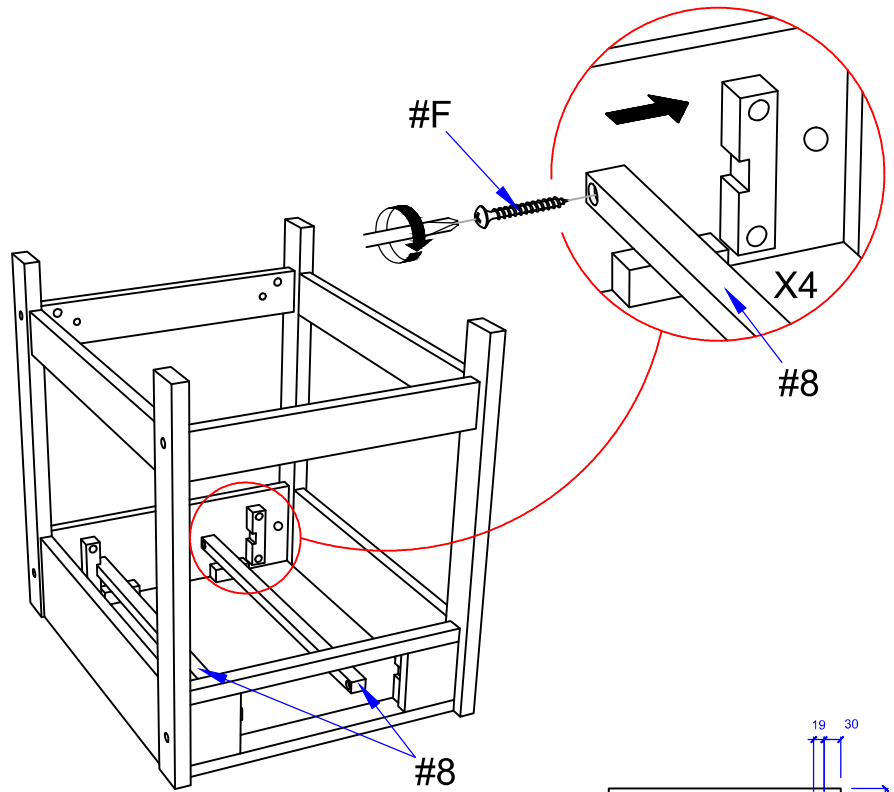

4

Part (#1) x1pc

Hardware (#F) x4pcs

Corner Marking

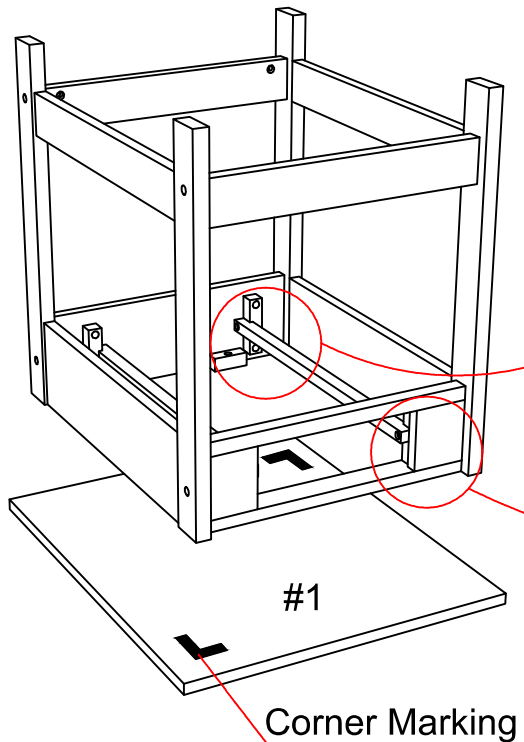

Place the fixed frame according
to the corner marking made on
Top Panel (#1).

ASSEMBLY INSTRUCTIONS

5

Part (#6) x1pc

Hardware (#I) x4pcs

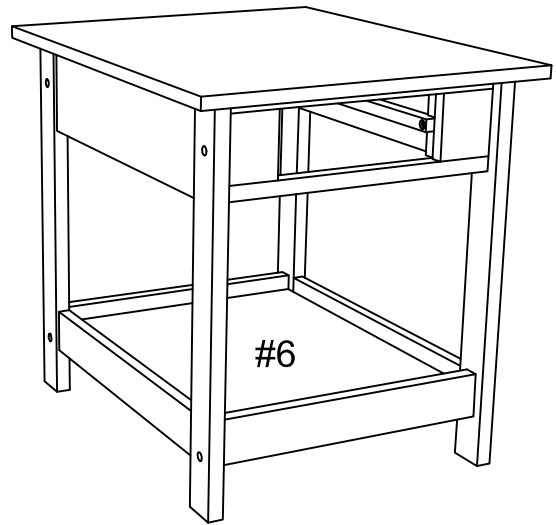
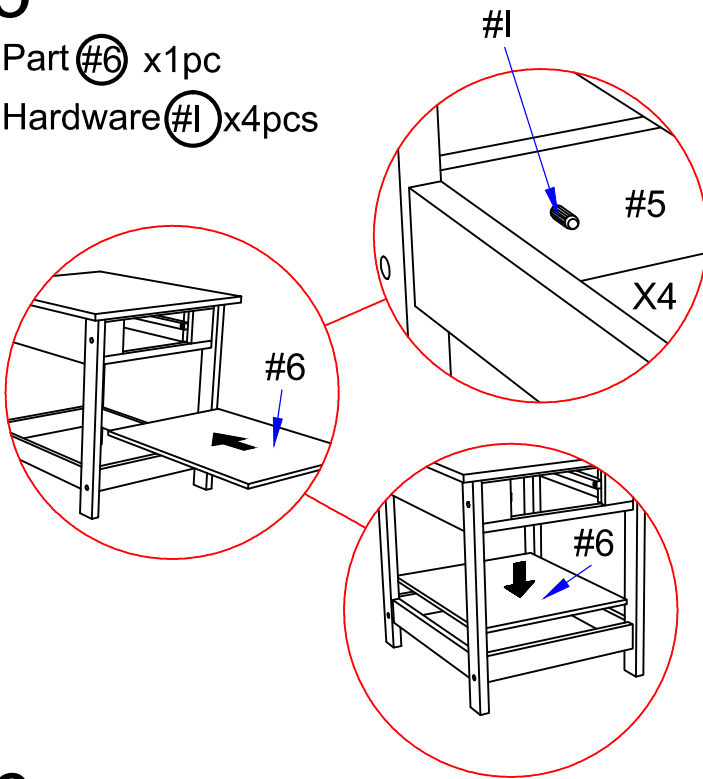

Slide Shelf Panel (#6) through front or back, then place it on the dowel that has been put on Front & Back Lower Panel (#5).

6

Part (#7) x1pc

Hardware (#G) x1pc

Hardware (#H) x1pc

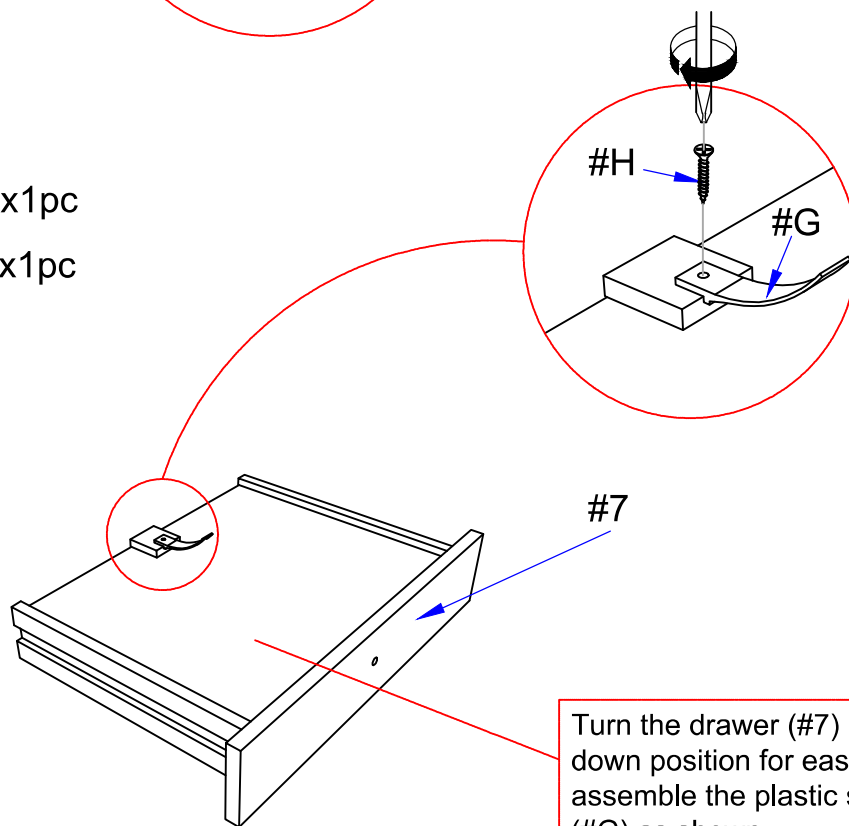

Turn the drawer (#7) upside down position for easy to assemble the plastic stopper (#G) as shown.

ASSEMBLY INSTRUCTIONS

7

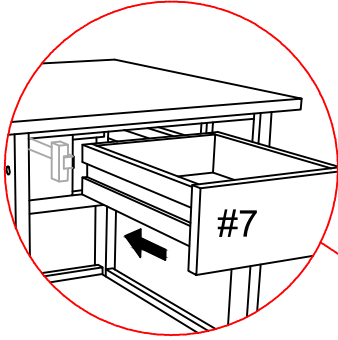
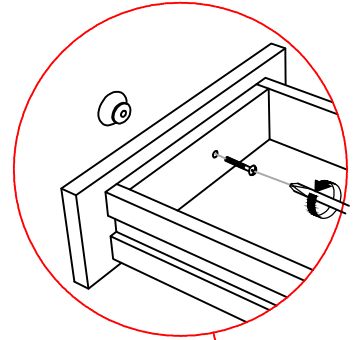

Align Drawer (#7) side with the Wooden Glide (#8) before sliding it in.

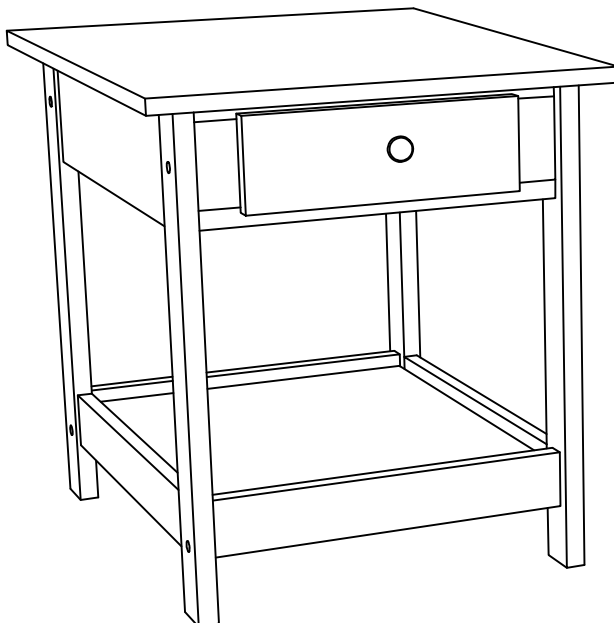
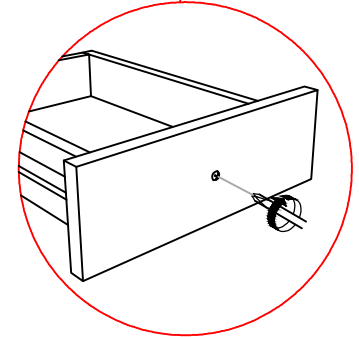
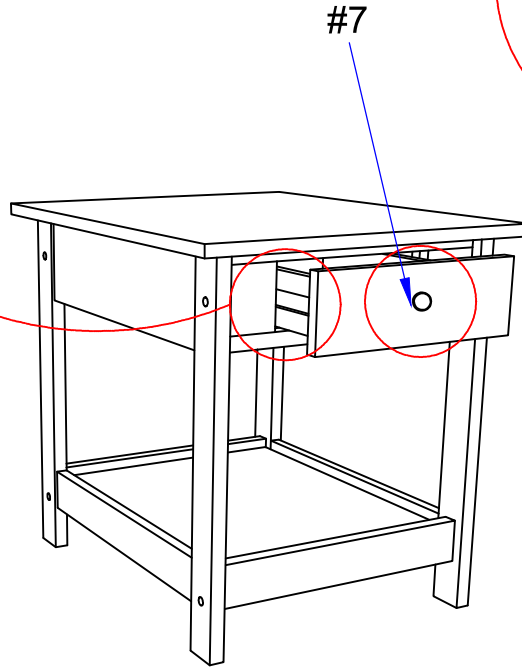

ASSEMBLY COMPLETED



Please ensure the furniture rests on an even and flat surface. If the product wobbles or feels loose, double-check all bolts and/or screws are properly tightened and secured.



Keep this handy!

Please retain this instruction manual and any order-related information for future reference.



Lift, don't drag!

To avoid damage to product please always LIFT the product when transporting or adjusting the placement.