

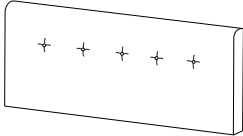









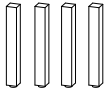

QUEEN BED

Components

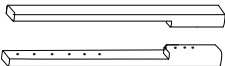
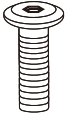
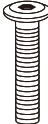
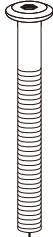
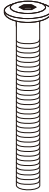
-  **A** X 1 pc
-  **C** X 1 pc
-  **D** X 2 pcs
-  **E** X 2 sets
-  **F** X 2 pcs
-  **G** X 2 pcs
-  **H** X 4 pcs
-  **I** X 2 pcs
-  **W** X 1 set

Hardware

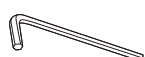
-  **J**
M8X20
4 pcs
-  **K**
M6X30
14 pcs
-  **L**
M6X70
6 pcs
-  **M**
M6X45
4 pcs
-  **N**
M4X32
8 pcs
-  **O**
M6
20 pcs
-  **Q**
M4
1 pc
-  **R**
M5
1 pc

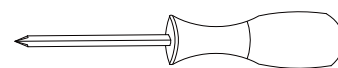

PHILLIPS SCREWDRIVER
REQUIRED
(NOT INCLUDED)

Parts are inside the headboard
in the compartment located
on the back of the headboard

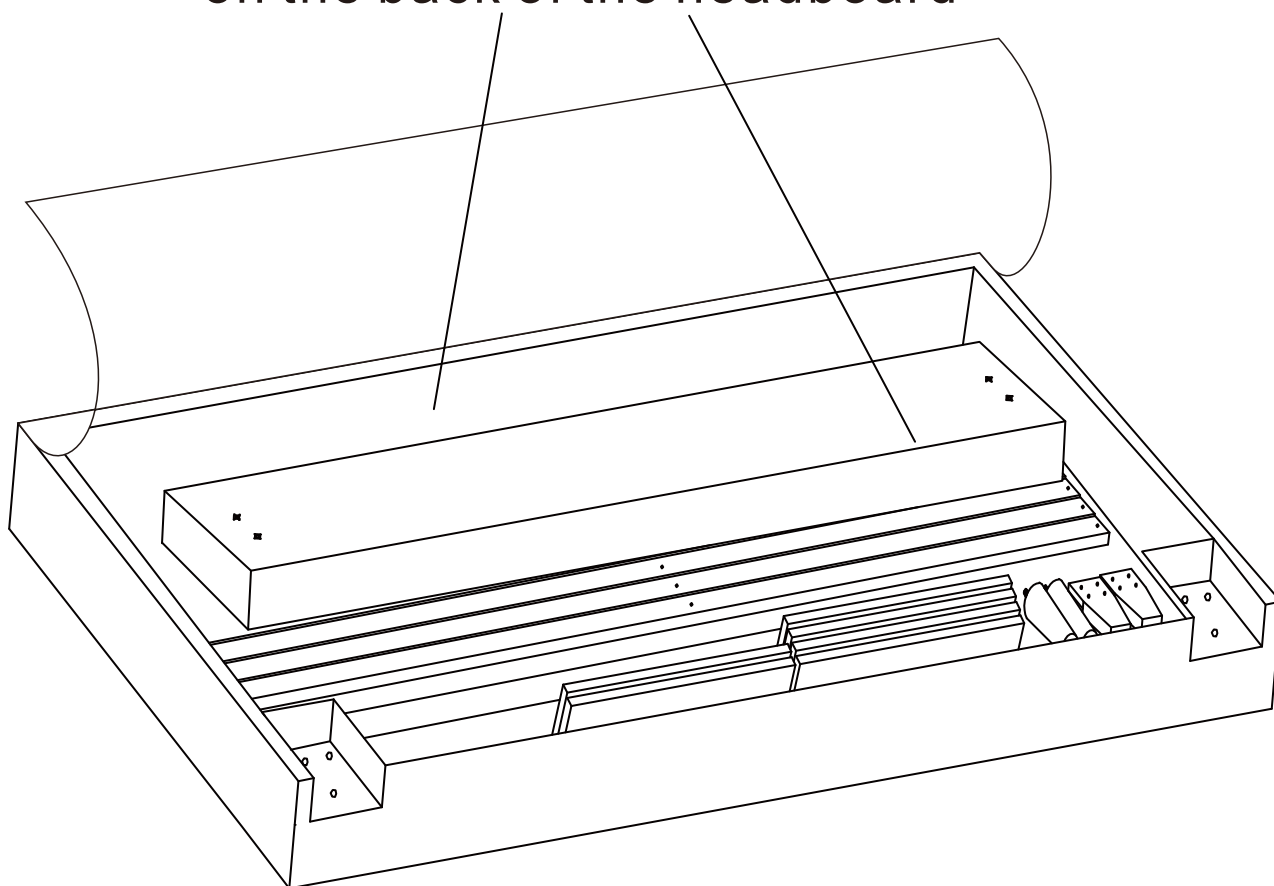

Remove parts from headboard compartment

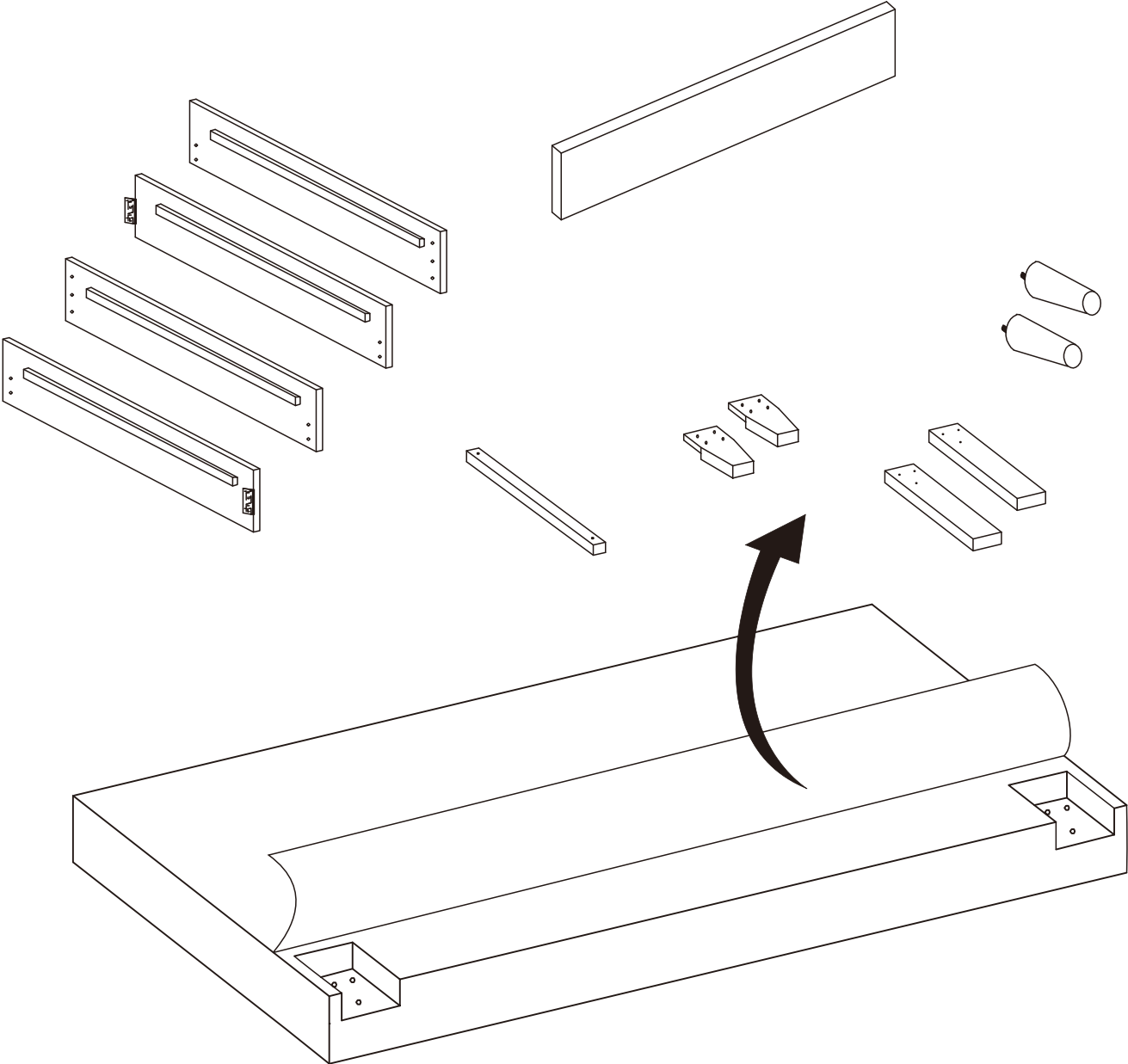

1

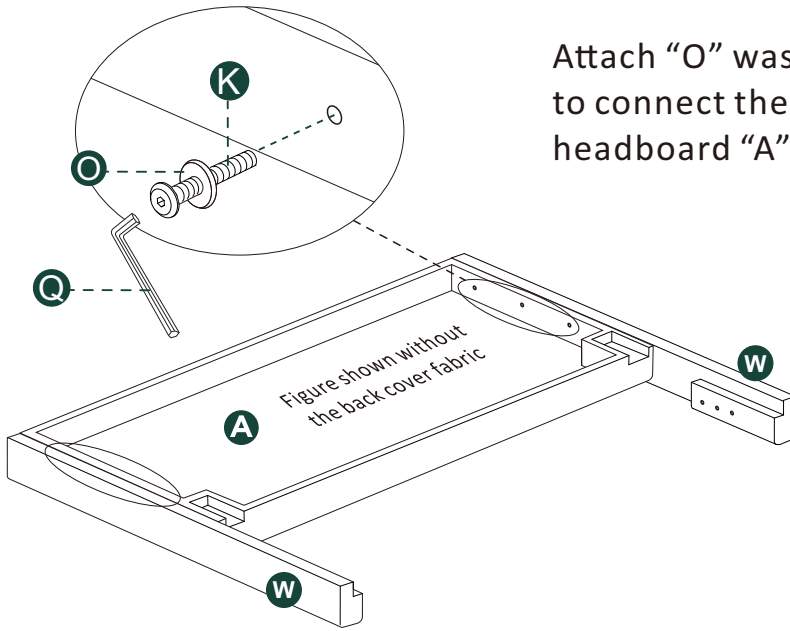

Attach "O" washer to "K" bolt. Use the "K" bolts to connect the wing "W" to the ends of the headboard "A". Tighten the "K" bolts.

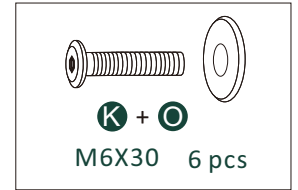

2

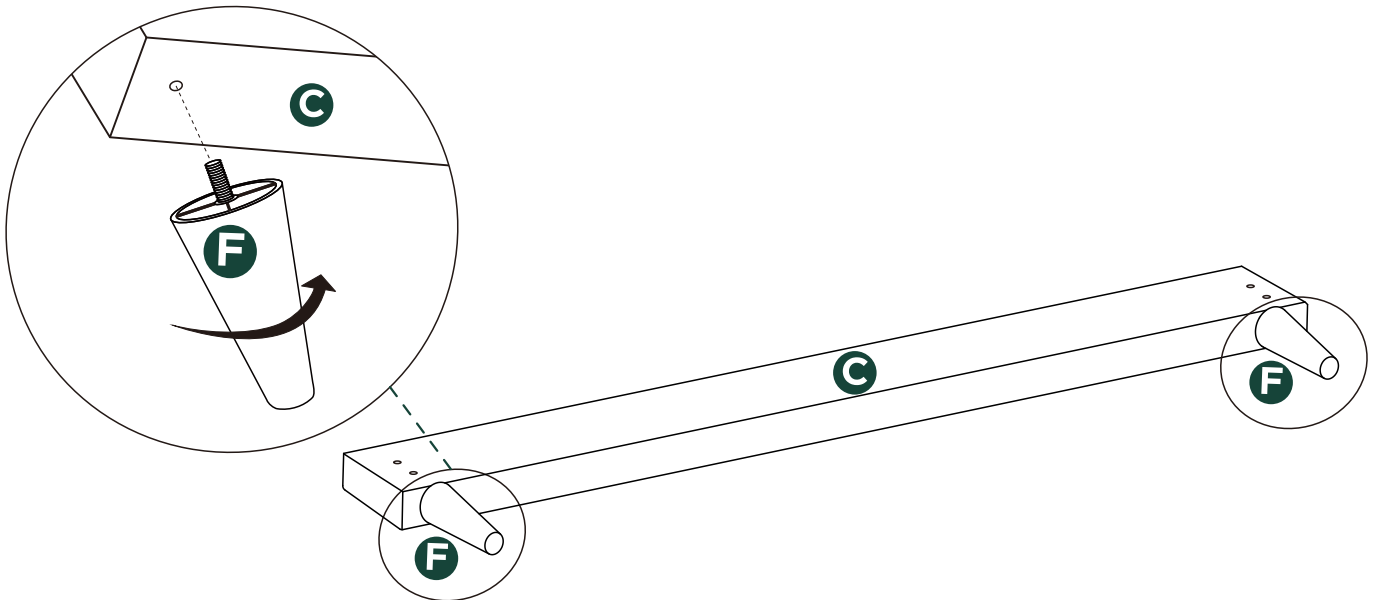

3

Thread "J" bolts into the holes in the footboard. Do not tighten. These will be tightened in later steps.

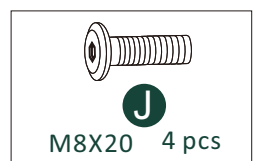
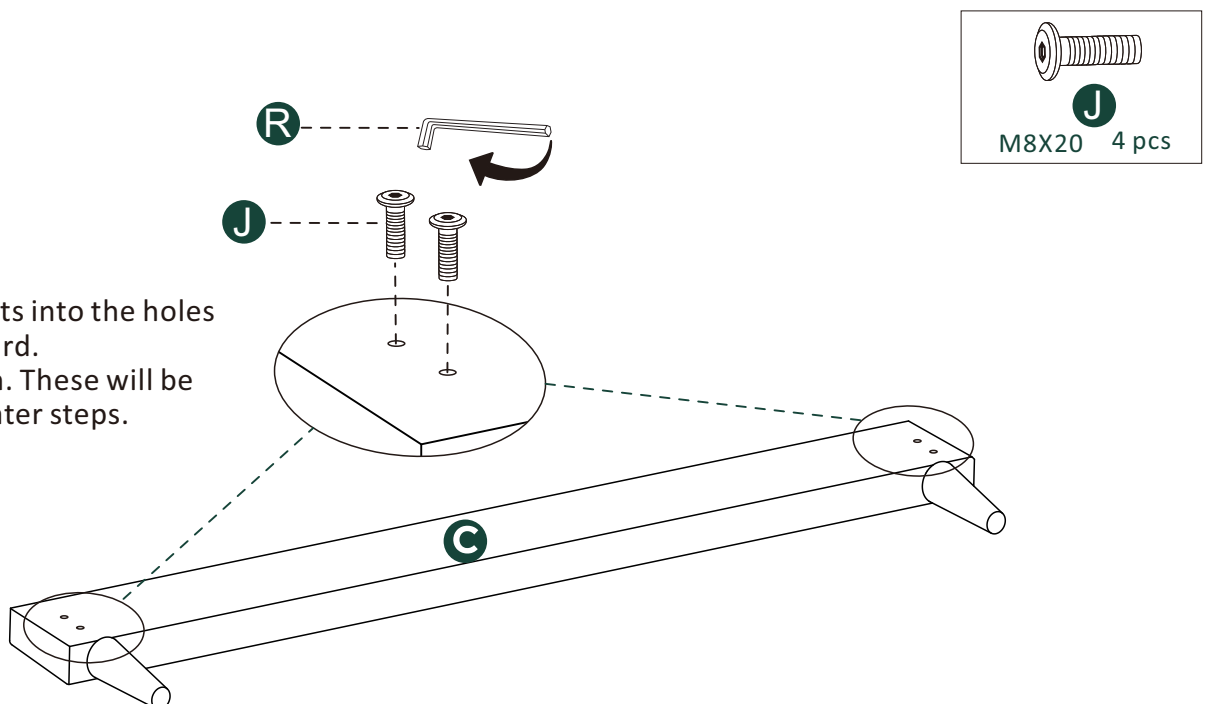

4

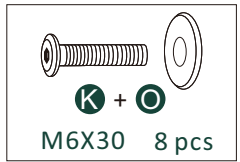
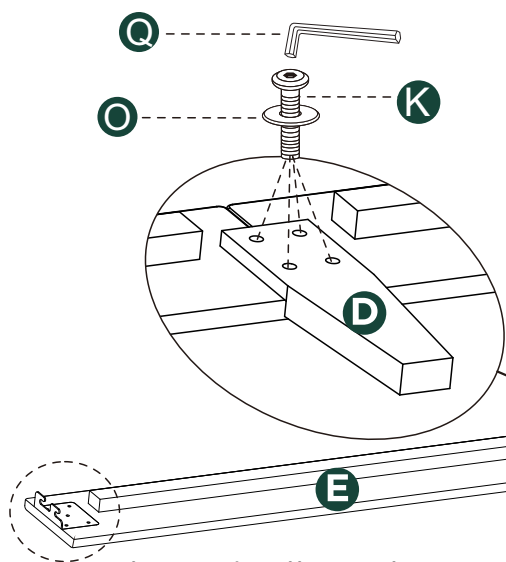

Attach "O" washers to "K" bolt. Connect the top and bottom of each side rail with a "D" side leg. Use the bolts to attach.

This end will attach to footboard "C"

This end will attach to wing "W"

5

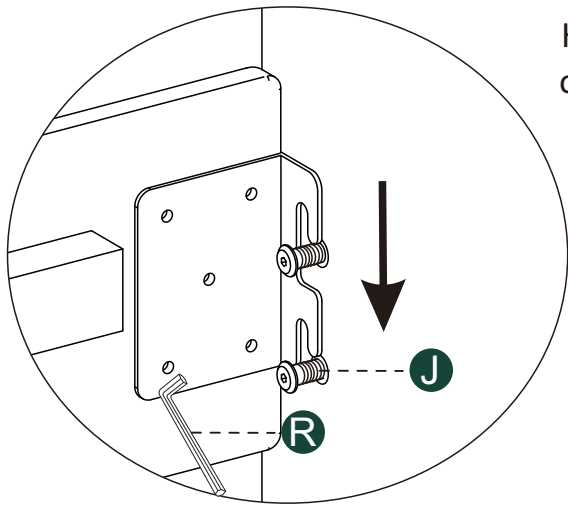

Hang the hooks at the ends of the side rails onto the "J" bolts in the footboard. Tighten the "J" bolt so the rails are secure.

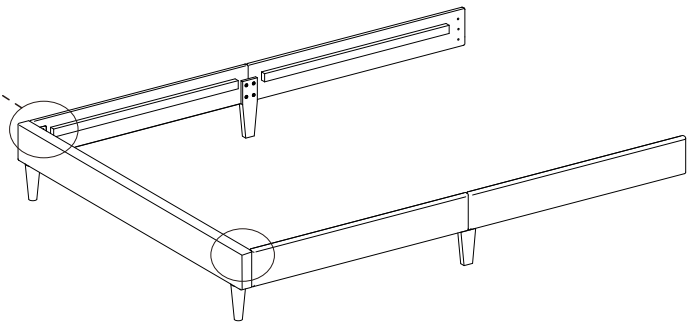

6

Attach "O" washer to "L" bolt. Use the "L" bolts to connect the ends of the side rails to the wings "W". Tighten the "L" bolts.

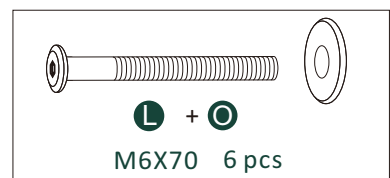
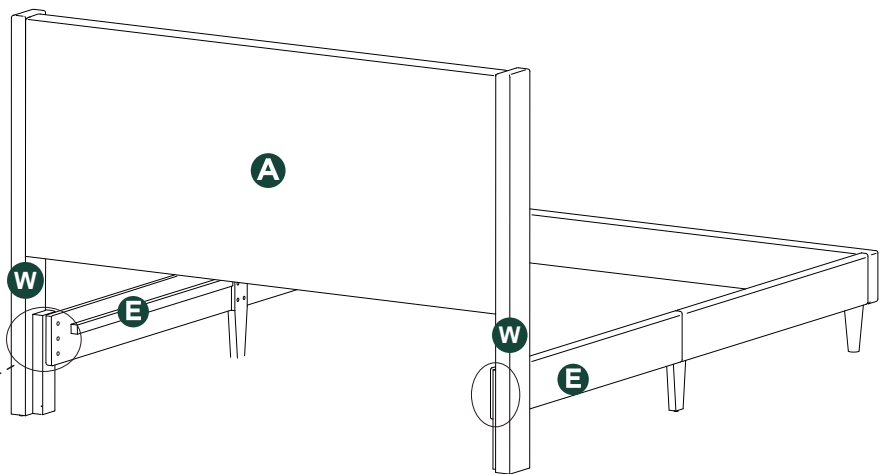
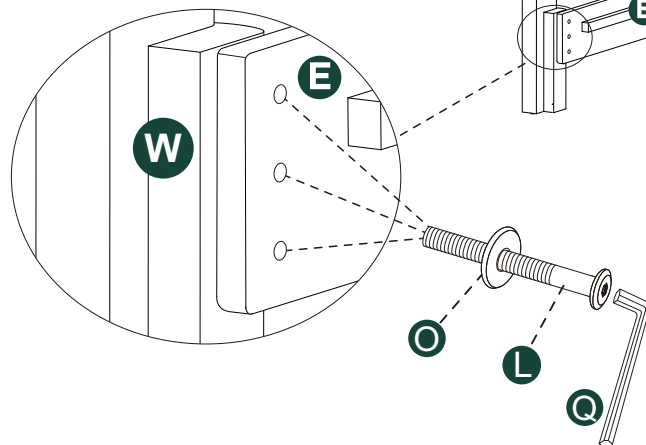

7

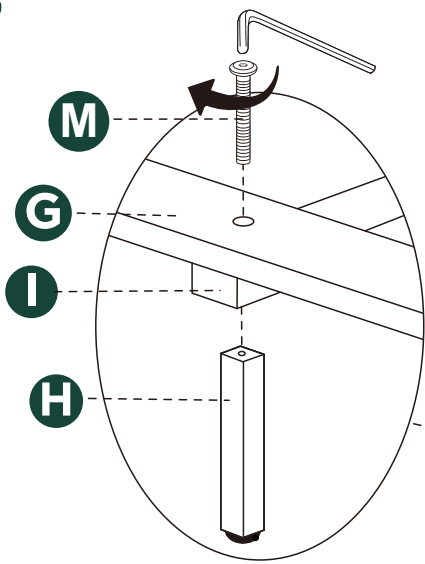

Assemble the slat system by attaching the slats to the “I” supports and “H” legs. First, extend the slats. Then, line up the holes in the slats with the holes in the “I” supports and the holes in the tops of the “H” legs. Use an “M” bolt through the holes to attach them together.

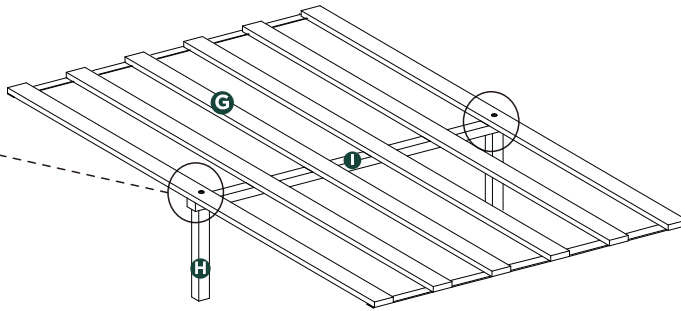

After the slat system is assembled, place the slats into the frame of the bed as shown below.

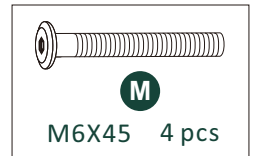

8

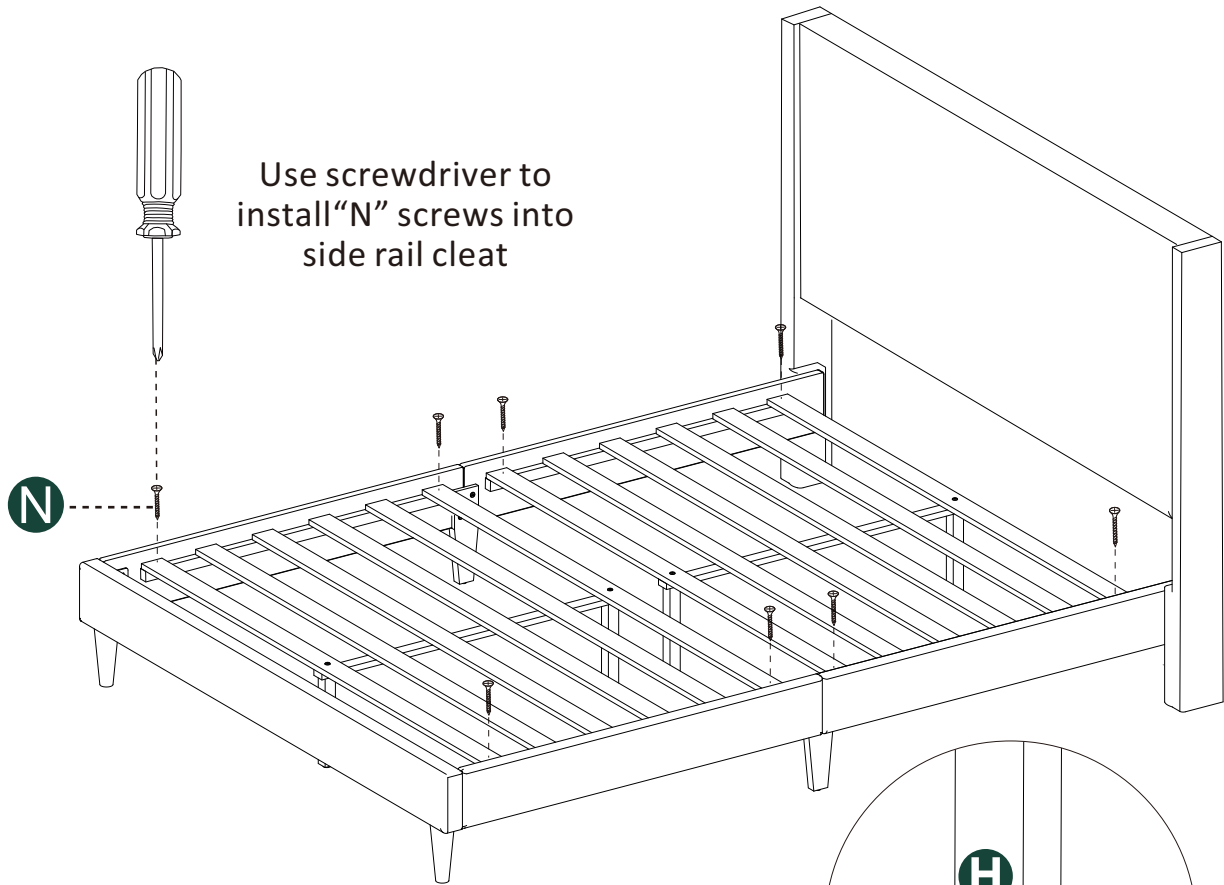

Use screwdriver to install “N” screws into side rail cleat

Finally, adjust slat leveling feet to touch floor

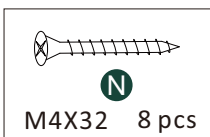
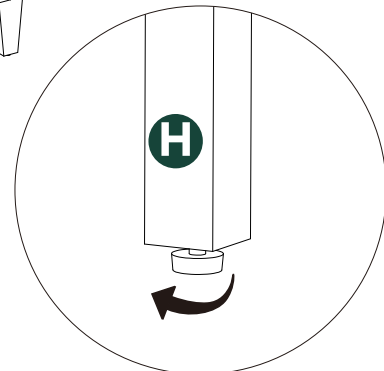

CAUTION:

Do not attempt to move the bed when fully assembled. This could result in damage to the rails, headboard, or footboard.

When placing furniture on non-carpeted flooring, we recommend the use of floor protection such as an area rug or furniture pads. Area rugs and padding not included with purchase.