

Installation & Assembly

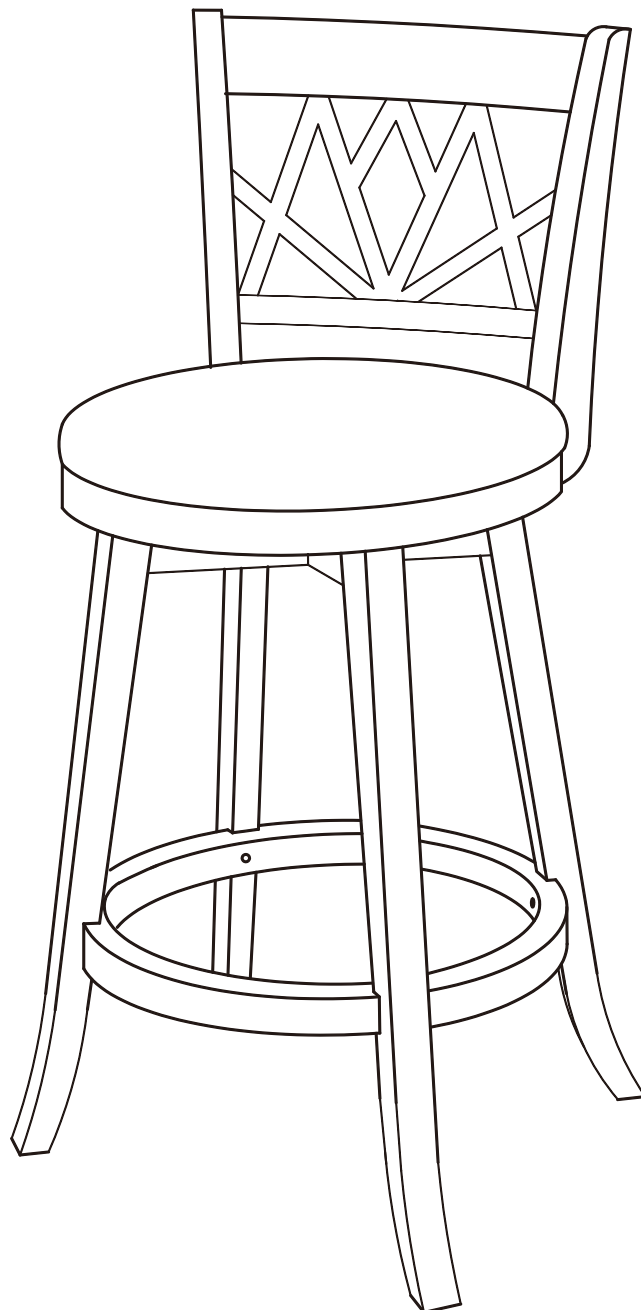

PART LIST		
ITEM	DESCRIPTION	QTY
A	Backrest	1 PC
B	Leg	4 PCS
C	Footrest	1 PC
D	X-cross with Swivel Plate	1 PC
E	Cushion with Apron	1 PC

A

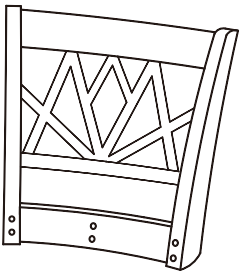

B

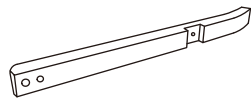

C

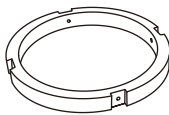



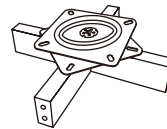



D

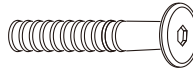
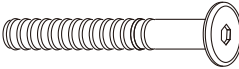
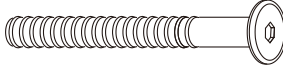

E



HARDWARE LIST

ITEM	DESCRIPTION	QTY
1	JCBC Screw M6 x 25mm 	4 PCS
2	JCBC Screw M6 x 35mm 	4 PCS
3	JCBC Screw M6 x 40mm 	6 PCS
4	JCBC Screw M6 x 45mm 	4 PCS
5	Spring Washer M6 x 13mm 	14 PCS
6	Flat Washer M6 x 16.5mm 	10 PCS
7	Wood Dowel M10 x 30mm 	4 PCS
8	Allen Key Small M4 x 110mm 	1 PC

STEP 1

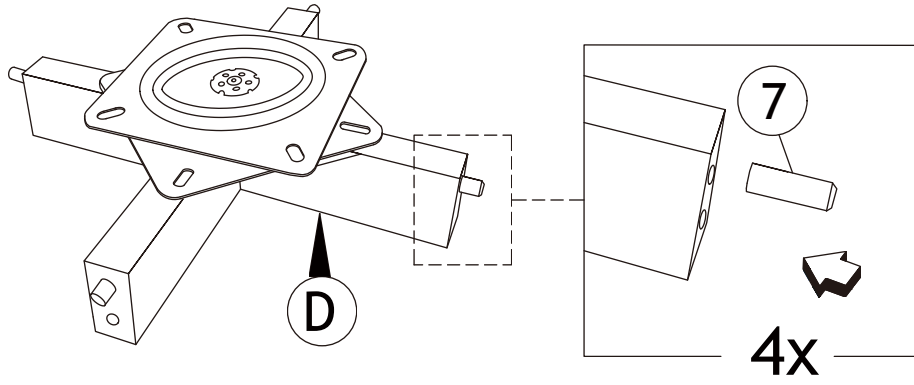

7	
---	--

STEP 2

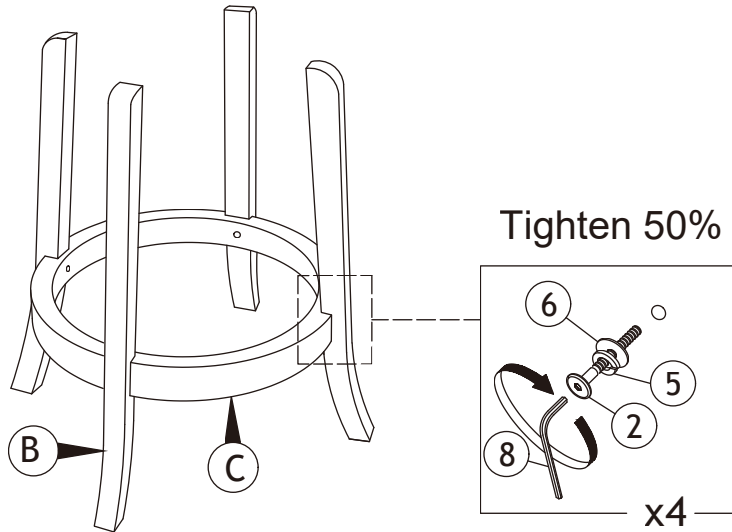

2	
5	
6	
8	

STEP 3

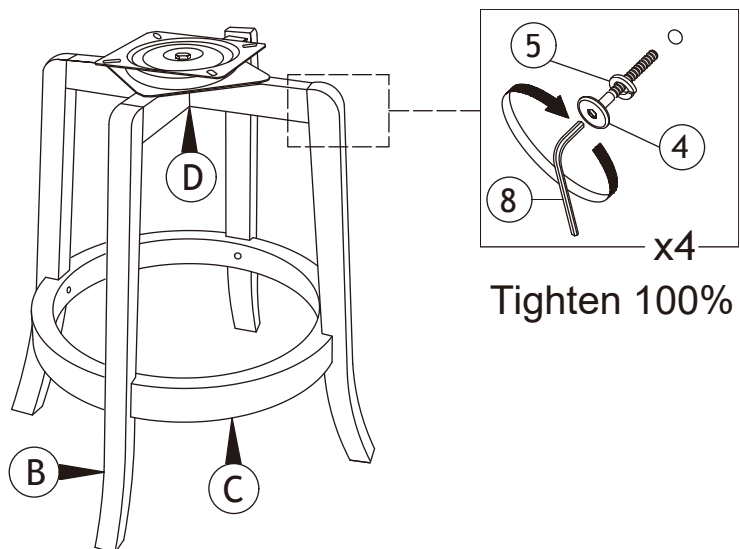

4	
5	
8	

STEP 4

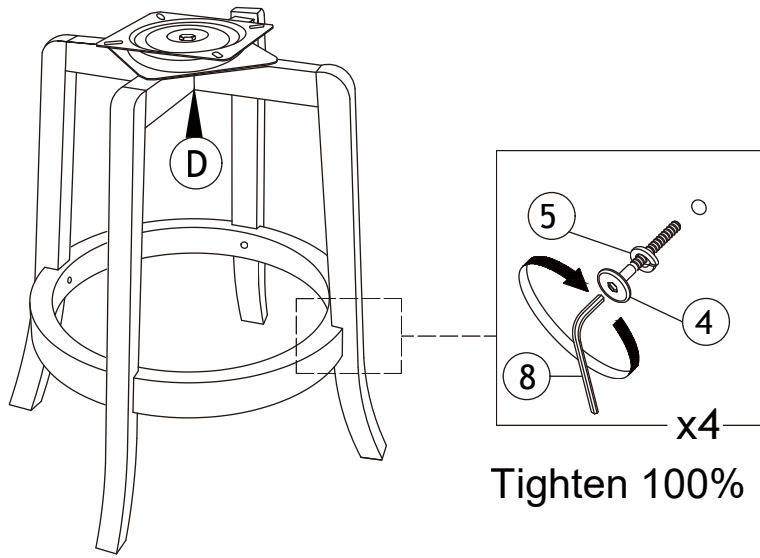

4	
5	
8	

STEP 5

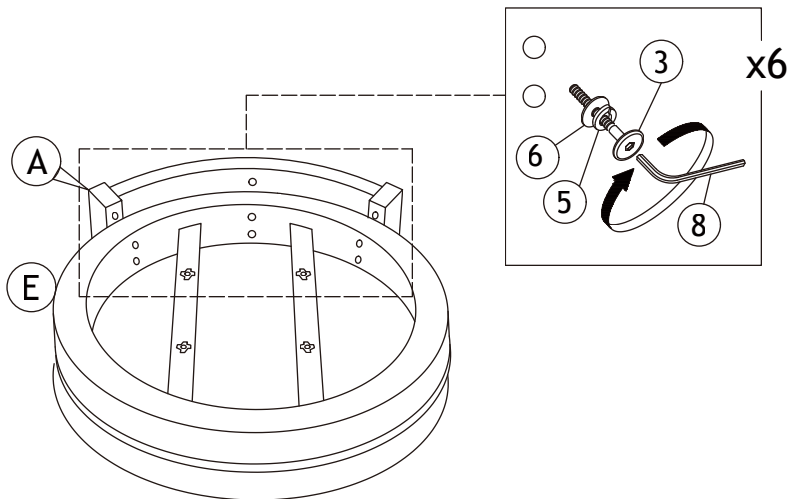

3	
5	
6	
8	

Insert 6 sets hardware first, then tighten part (A) with part (E) after alignment is done.

STEP 6

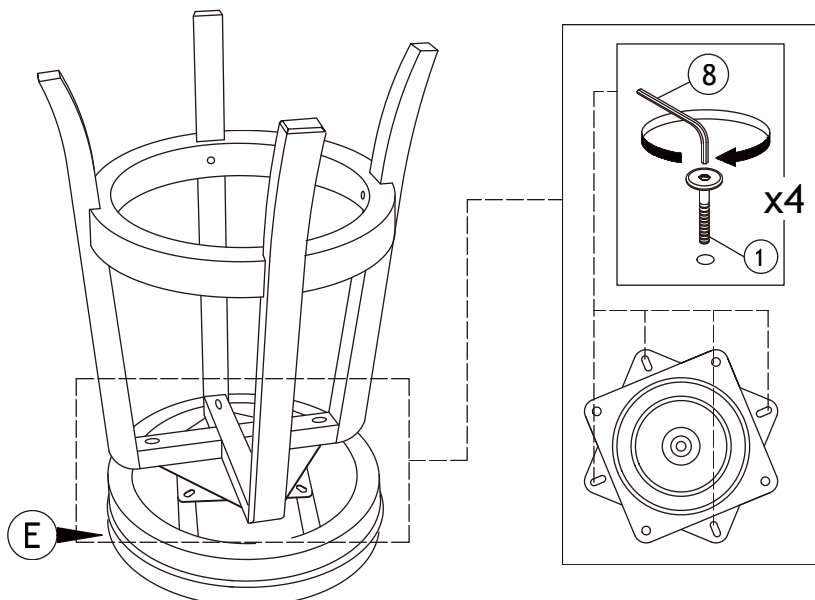

1	
8	

STEP 7

COMPLETE ASSEMBLY

